

### STEP: 1 Assemble Main Panel

Carefully place Fin 1 and Fin 2 onto the Main Panel  
(Match the number on the Fin to the number on the Main Panel)

Secure with Small Bolt and Small Nut

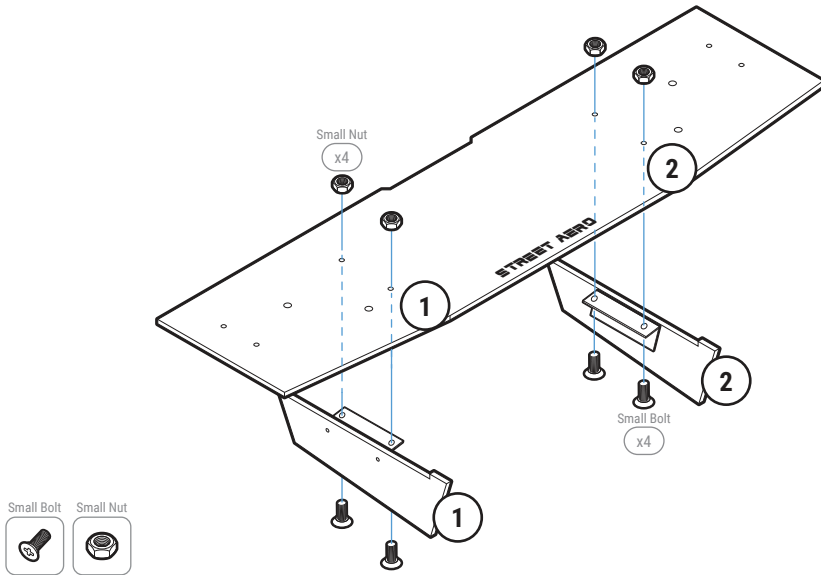

### STEP: 2 Remove OEM Fastener

Carefully remove the 2 OEM fastener that connects to the bumper support bracket located under the bumper

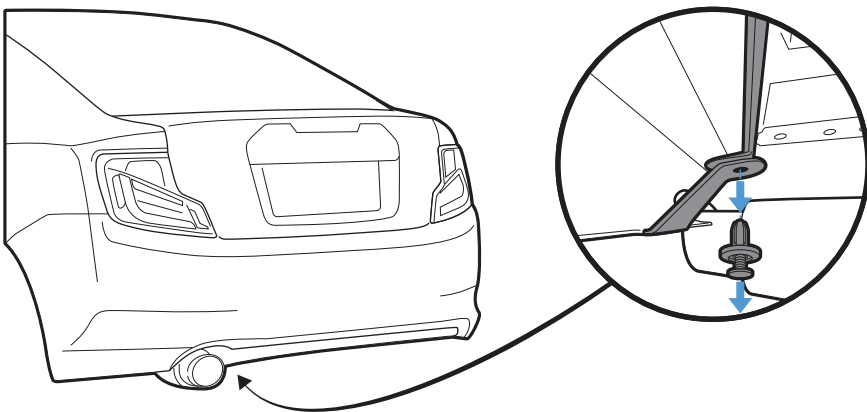

### STEP: 3 Install Mounting Bracket

Mount the assembled Main Panel to the bumper by securing Mounting Bracket SN-2 to the OEM mounting hole on **STEP: 2** with M6 70mm Bolt, Finishing Washer, Washer, and Nut  
**NOTE:** Reach under to place Washer and Nut inside the bumper on top of the 2 bumper support bracket

Align Mounting Bracket SN-1 and SN-3 to its correct spot then Mark and Pre-Drill into the bumper  
**NOTE:** Use the hole on top of SN-1 and SN-3 to mark the drill location  
**NOTE:** Mounting Bracket may need to be removed before pre-drilling

Secure Mounting Bracket SN-1 and SN-3 to the bumper with M6 40mm Bolt, Finishing Washer, Washer, and Nut  
**NOTE:** Reach under the bumper to place the Washer and Nut inside the bumper

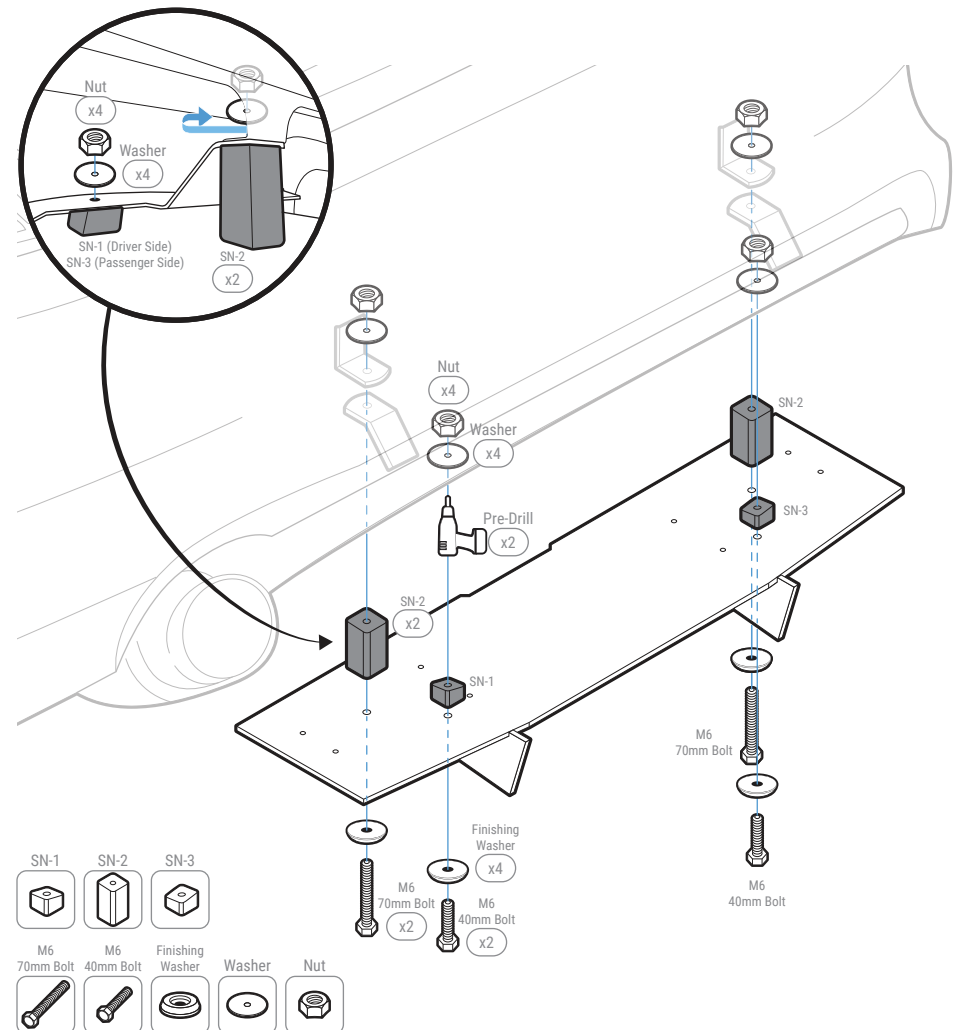

**IMPORTANT: DO NOT** over tighten or use power tools to mount the Mounting Brackets

**STEP: 4** *Mount the Rear Diffuser*

Remove the 2 OEM Push Pin, located on both sides, under the bumper near the rear wheel tires

Attach and secure Mounting Bracket SN-5 and SN-7 to the Side Panel with M6 16mm Bolt, Finishing Washer, and Nut

Place M6 25mm Bolt into the hex socket behind Mounting Bracket SN-5 and SN-7  
**NOTE:** Push the Bolt all the way into the socket to prevent it from falling out

Attach the Side Panel to the Main Panel with Small Bolt and Small Nut

Mount the Side Panel to the bumper by securing the M6 25mm Bolt on Mounting Bracket SN-5 and SN-7 with Washer and Nut

**NOTE:** Reach under or to the side of the bumper to place the Washer and Nut inside the bumper

Continue mounting the Side Panel by securing Mounting Bracket SN-4 and SN-6 with M6 40mm Bolt, Finishing Washer, Washer, and Nut

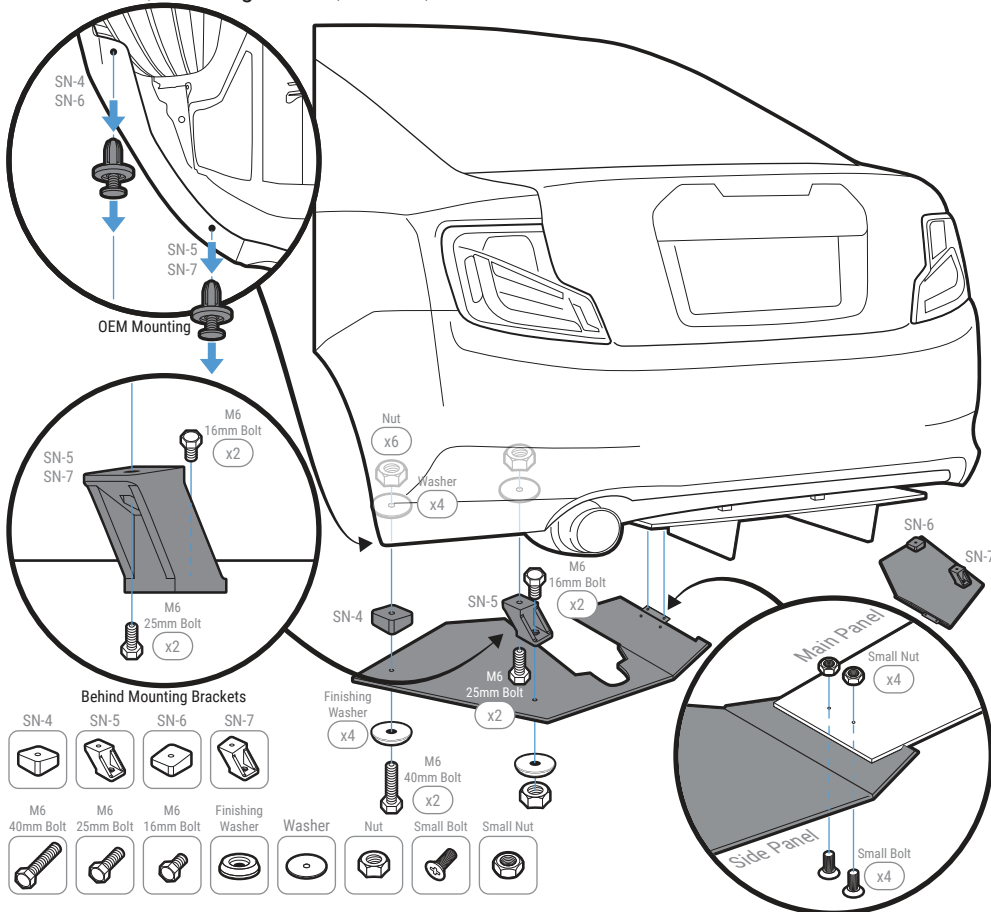

**INSTALLATION GUIDE**  
**2011-2013 Scion TC**  
**(OEM and Aftermarket Exhaust)**  
**ACM Rear Diffuser**

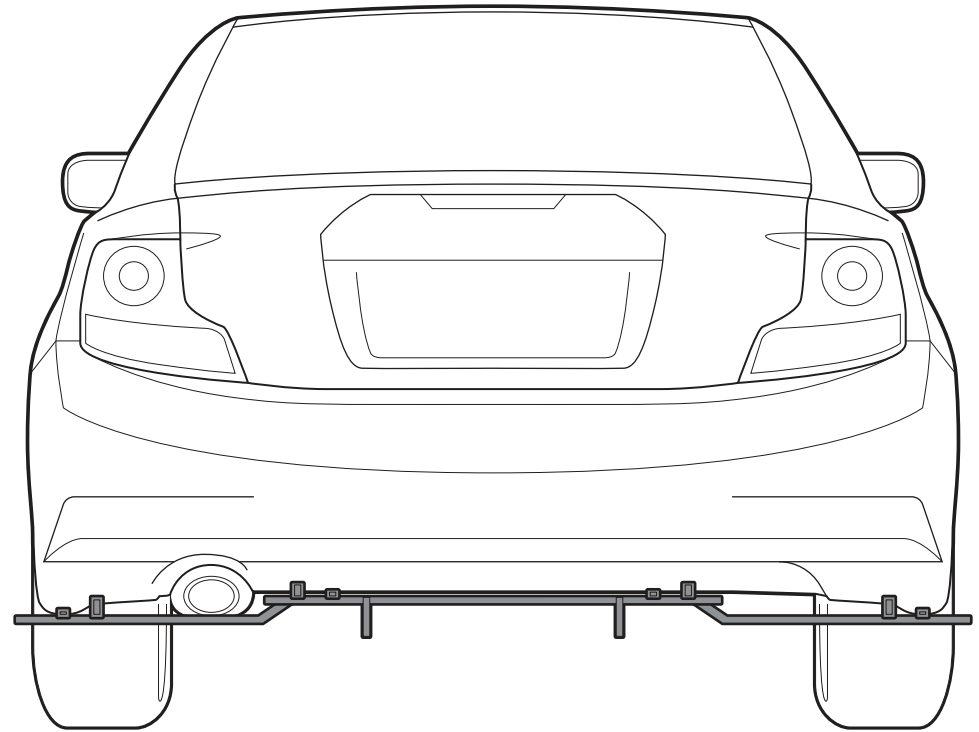

s-rda-sci-01-e1

s-rda-sci-02-e1

www.streetaero.com

info@streetaero.com

