

STEP: 1 Assemble Rear Diffuser

Carefully place Fin 1 and Fin 2 onto the Main Panel
(Match the number on the Fin to the number on the Main Piece)

Secure with Small Bolt and Small Nut

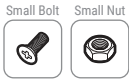
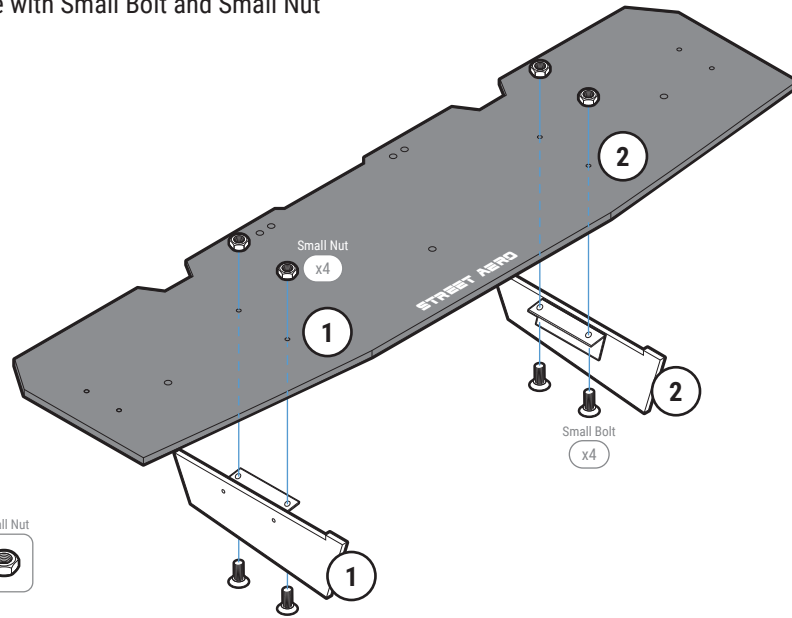

STEP: 2 Remove OEM Bolts

Remove the two OEM Bolts located under the bumper

NOTE: (Mark where the OEM Bolts are located this is where the Main Panel will be mounted)

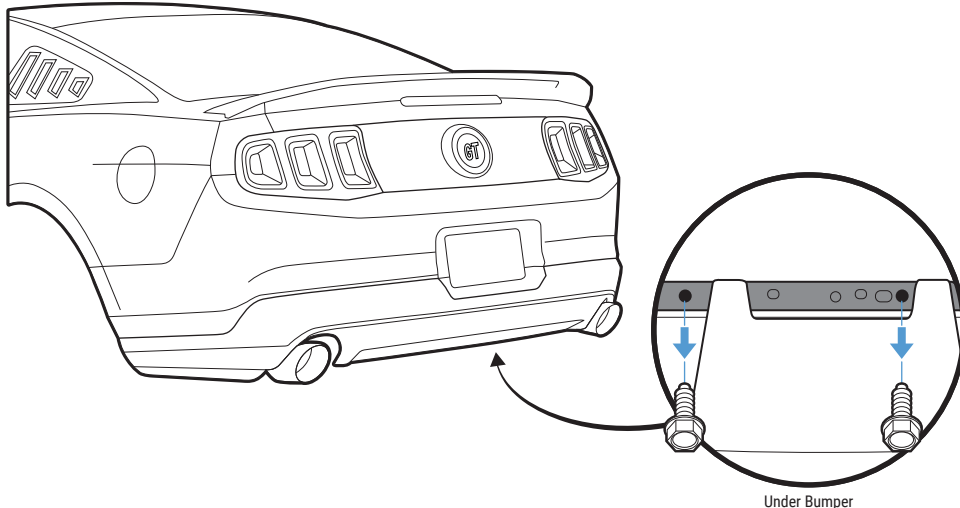

STEP: 3 Mount Main Panel

Use the OEM mounting holes from "STEP: 2" to mount the assembled Main Panel to the bumper by securing both Mounting Bracket FD-22 with provided M6 55mm Bolt and Finishing Washer

Mark and pre-drill under the bumper where the Well Nut would be mounted with 13/32 Bit

NOTE: Use the hole in the center of the Main Panel to mark the location on the bumper
(Main Panel may need to be removed before pre-drilling)

Attach the Well Nut to the Bumper

NOTE: push the Well Nut all the way into the pre-drilled hole
(Main Panel may need to be removed)

Mark and pre-drill the left and right side of the bumper where both Mounting Bracket FD-23 would be mounted with 1/4 Bit

NOTE: Use the hole on the left and right side of the Main Panel to mark the location on the bumper
(Main Panel may need to be removed before pre-drilling)

Attach the Main Panel to the Bumper by securing both Mounting Bracket FD-23 with provided M6 40mm Bolt, Finishing Washer, Washer, and Nut

NOTE: Reach under or to the side of the bumper to place the Washer and Nut inside the bumper

Finish mounting by securing the Main Panel to the Well Nut with M6 40mm Bolt and Finishing Washer

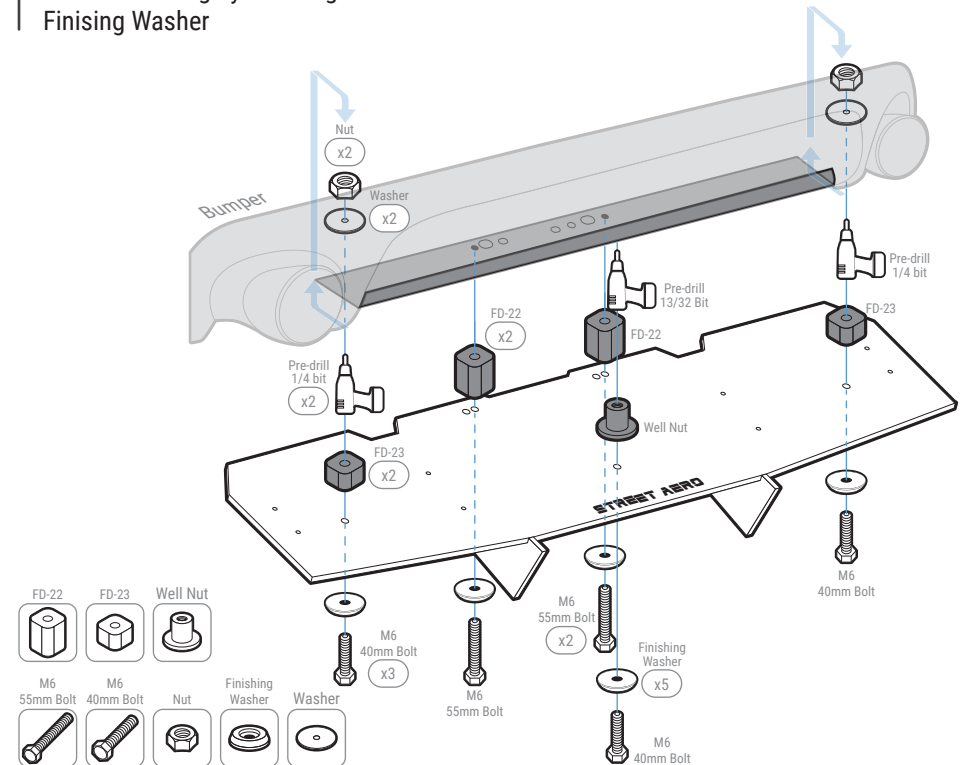

IMPORTANT: DO NOT over tighten or use power tools to mount the Mounting Brackets

STEP: 4 Mount the Rear Diffuser

Attach and secure Mounting Bracket FD-24 and FD-25 to the Side Panel with M6 16mm Bolt, Finishing Washer, and Nut

NOTE: Push the bolt all the way into the socket to prevent it from falling out

Attach the Side Panel to the Main Panel with Small Bolt and Small Nut

NOTE: Do Not tighten Small Bolt on the Side Panel to the Main Panel
(you may need to remove the Side Panel to pre-drill)

Mark where the mounting hole is to the bumper

NOTE: Use the hole on the side of Mounting Bracket FD-24, FD-25, FD-26, and FD-27 to mark the drill location

Pre-drill into the bumper

IMPORTANT!: Use 13/32 Bit for Mounting Bracket FD-24 and FD-26 use 1/4 Bit for FD-25 and FD-27

Install the Side Panel to the Main Panel and bumper by securing Mounting Bracket FD-24 and FD-26 with provided M6 25mm Bolt and Well Nut

Secure Mounting Bracket FD-25 with provided M6 25mm Bolt, Washer, and Nut

NOTE: Use the sides near the wheels to secure the Washer and Nut inside the bumper

Repeat to install Passenger Side Panel to the Main Panel and bumper

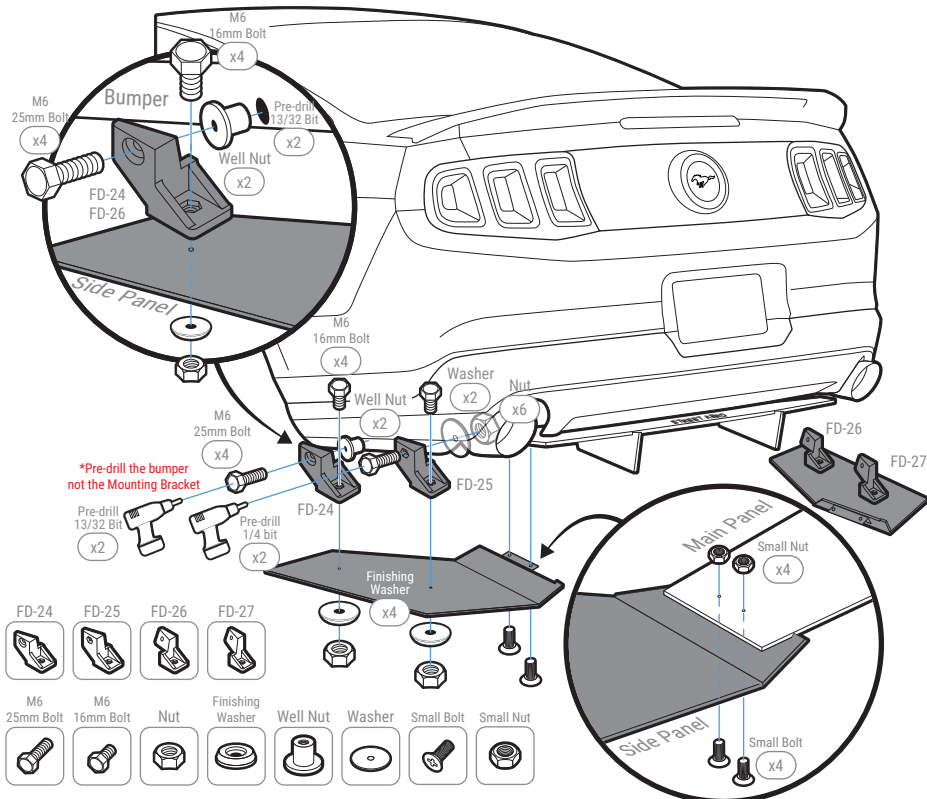

INSTALLATION GUIDE

2010-2012 Ford Mustang GT

ACM Rear Diffuser

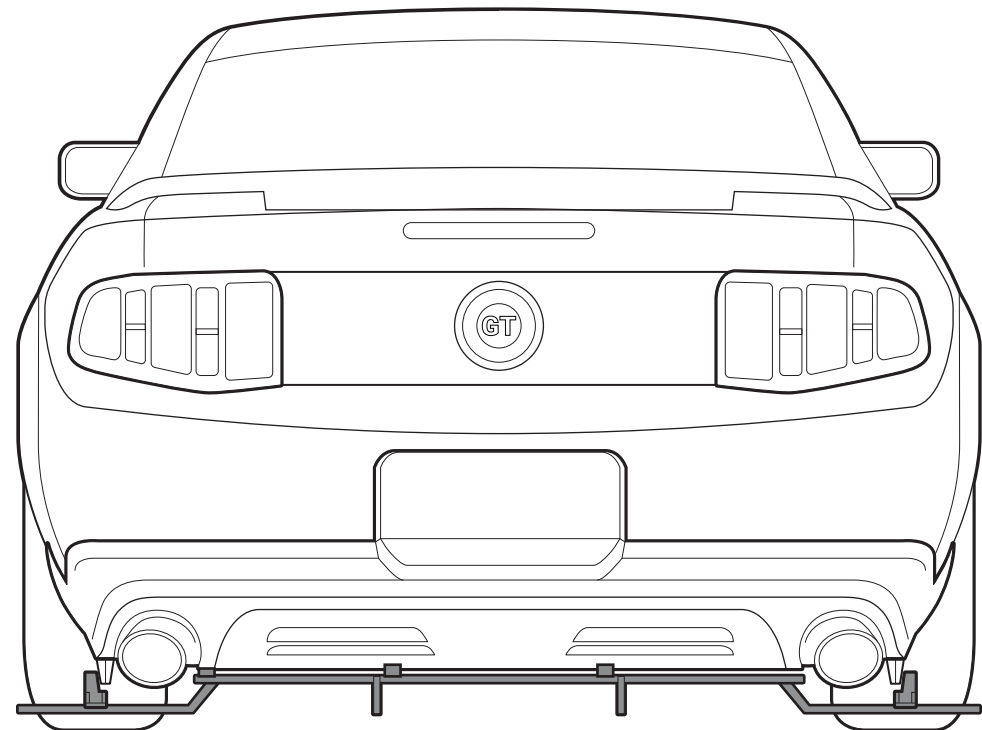

s-rda-frd-09-e1

www.streetaero.com

