

### STEP: 1 Assemble Main Panel

Carefully place Fin 1, 2, 3, and 4 onto the Main Panel  
(Match the number on the Fin to the number on the Main Panel)

**NOTE:** To prevent scratches keep the Fin as straight as possible

Secure with Small Bolt and Small Nuts

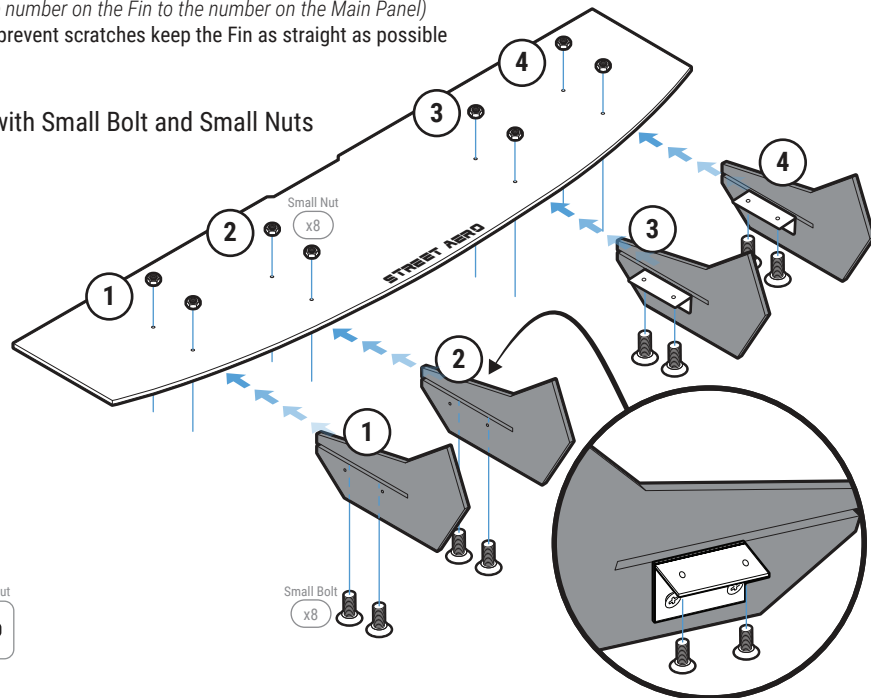

### STEP: 2 Remove OEM Bolt

Remove the two OEM Bolts located under the Bumper

**NOTE:** (Mark where the OEM Bolts are located this is where the Main Panel will be mounted)

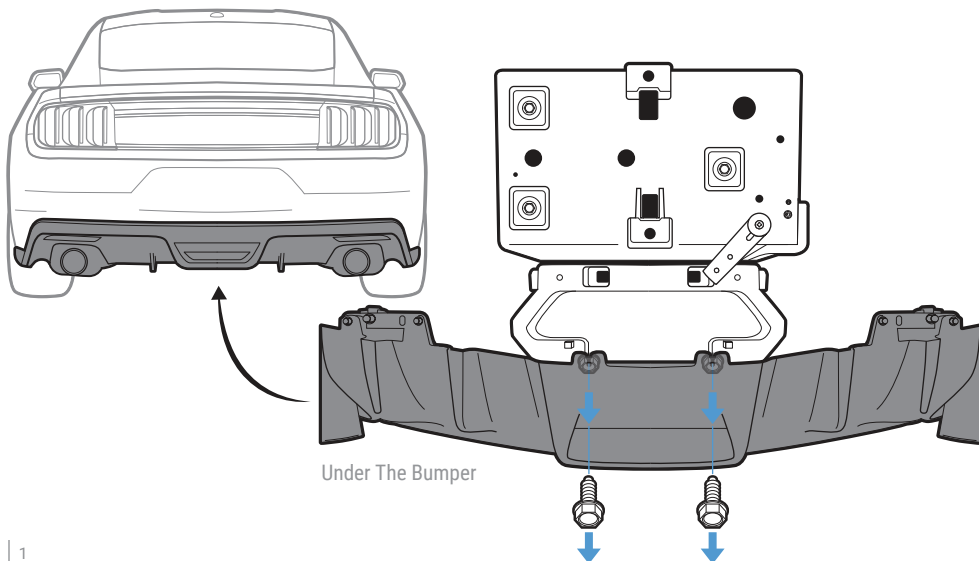

### STEP: 3 Mount Main Panel

Mark where the OEM Mounting hole is from **STEP: 2** onto the assembled Main Panel

Pre-drill through the Main Panel where the OEM mounting location is

Mount the assembled Main Panel to the bumper by securing M6 25mm Bolt and Finishing Washer to the OEM mounting hole

Continue mounting by drilling through the Main Panel into the bumper where the Main Panel has the most contact with the bumper and secure with M6 25mm Bolt, Finishing Washer, Washer, and Nut

**NOTE:** Reach under the bumper to place the Washer and Nut inside the bumper

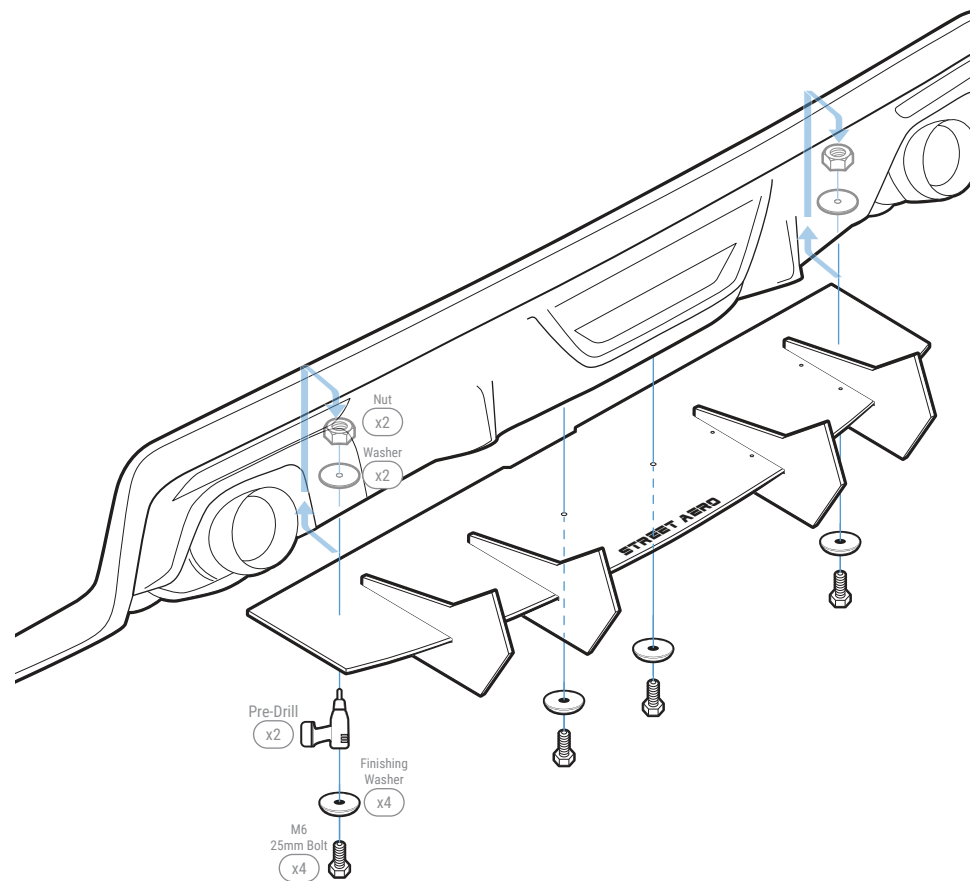

**STEP: 4** *Mount Side Panel*

Assemble Side Fin 1 to the Driver Side Panel and secure with Small Bolt and Small Nut

Align the assembled Side Panel to the bumper

Mark where the Side Panel has the most contact to the bumper

Pre-drill through the Side Panel and into the bumper

Secure the Side Panel to the bumper with provided M6 25mm Bolt, Finishing Washer, Washer, and Nut

**NOTE:** Reach under the bumper to place the Washer and Nut inside the bumper

Repeat to mount Passenger Side Panel to the bumper

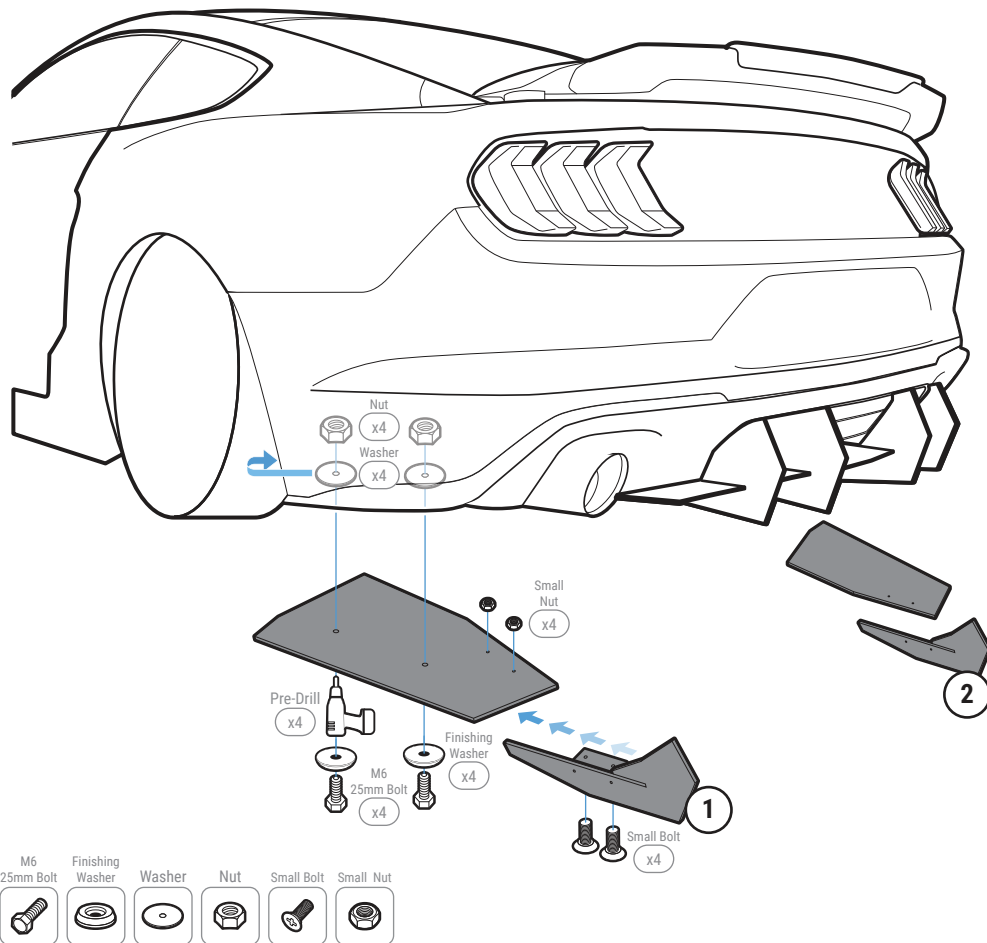

**INSTALLATION GUIDE**  
**2018-2023 Ford Mustang**  
**(EcoBoost) Classic Edition**  
**ACM Rear Diffuser**

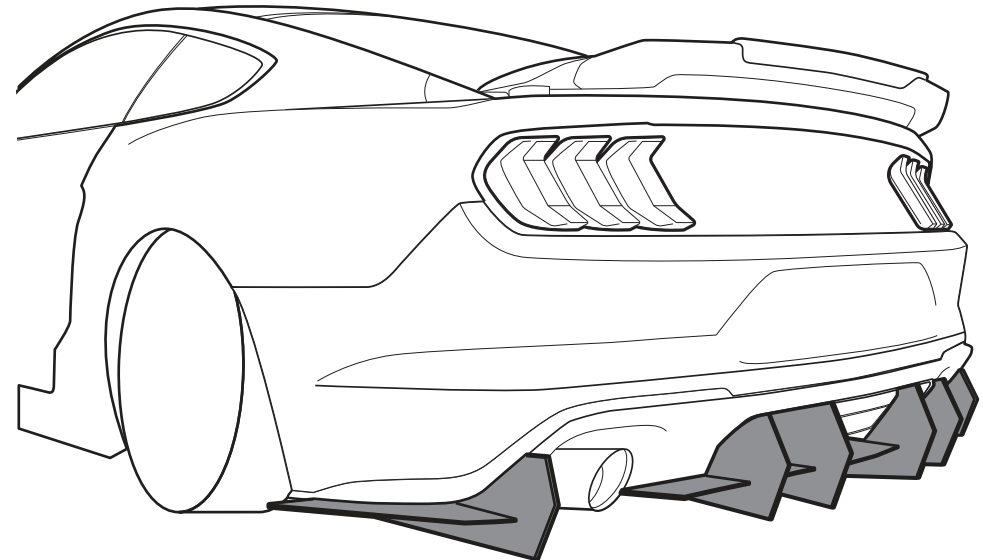

s-rda-frd-08

www.streetaero.com

info@streetaero.com