

STEP: 1 Assemble Main Panel

Carefully place Fin 1, 2, 3, 4 onto the Main Panel
(Match the number on the Fin to the number on the Main Panel)

Secure with Small Bolt and Small Nut

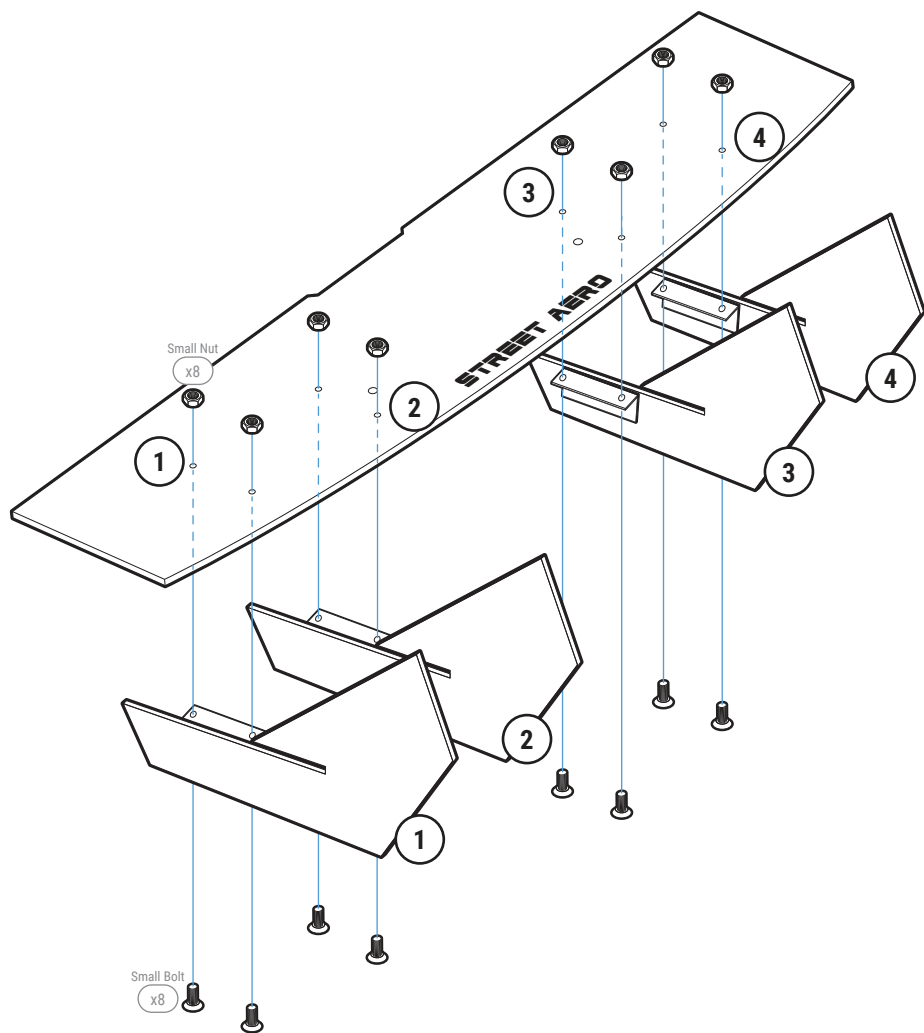

STEP: 2 Install Main Panel

Align the assembled Main Panel to the bumper

Mark and pre-drill into the bumper by using the two mounting holes on the Main Panel
NOTE: Main Panel may need to be removed before drilling

Mark and pre-drill through the Main Panel and into the bumper on the left and right side of the Main Panel where there is the most contact surface
NOTE: Main Panel may need to be removed before drilling

Secure the center of the Main Panel to the bumper with M6 40mm Bolt, Washers, 0.5" Cut Spacer, and Nut

NOTE: Reach under the bumper to place the Washer and Nut inside the bumper

Secure the left and right side with M6 25mm Bolt, Washers, and Nut

NOTE: Reach under the bumper to place the Washer and Nut inside the bumper

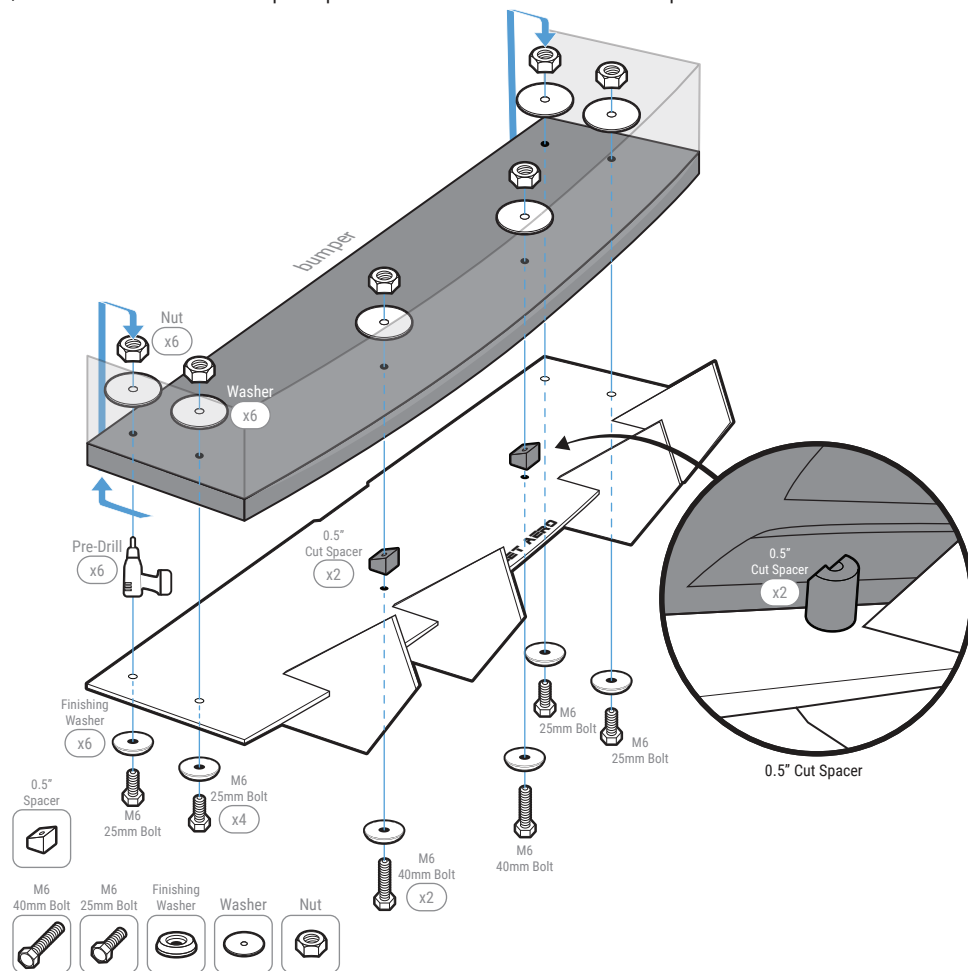

STEP: 3 *Mount the Rear Diffuser*

Align the Side Panel to the bumper

Mark where the Side Panel has the most contact point to the bumper

IMPORTANT: Make sure the hole is not too close to the edge make enough room to place the Washer and Nut inside the bumper

Pre-drill through the Side Panel and into the bumper

Attach and secure the Side Panel to the bumper with M6 25mm Bolt, Finishing Washer, Washer, and Nut

NOTE: Reach under or to the side of the bumper to place the Washer and Nut inside the bumper

Repeat to install Passenger Side Panel to the bumper

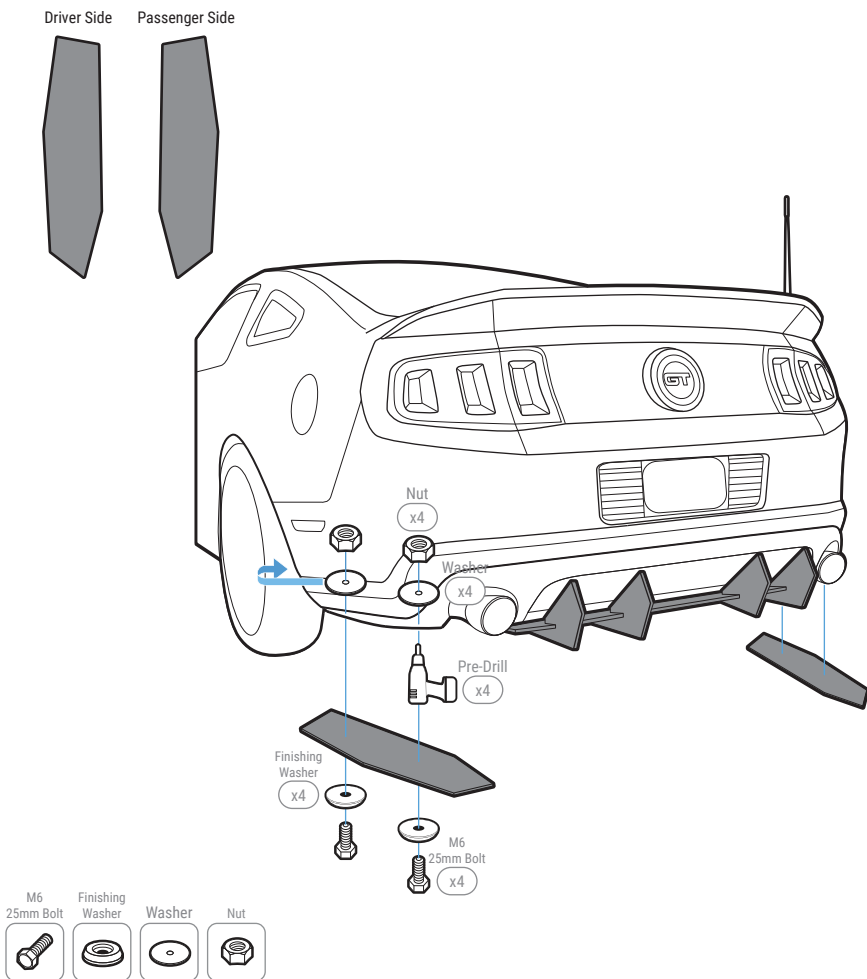

INSTALLATION GUIDE
2013-2014 Ford Mustang
Classic Edition
ACM Rear Diffuser

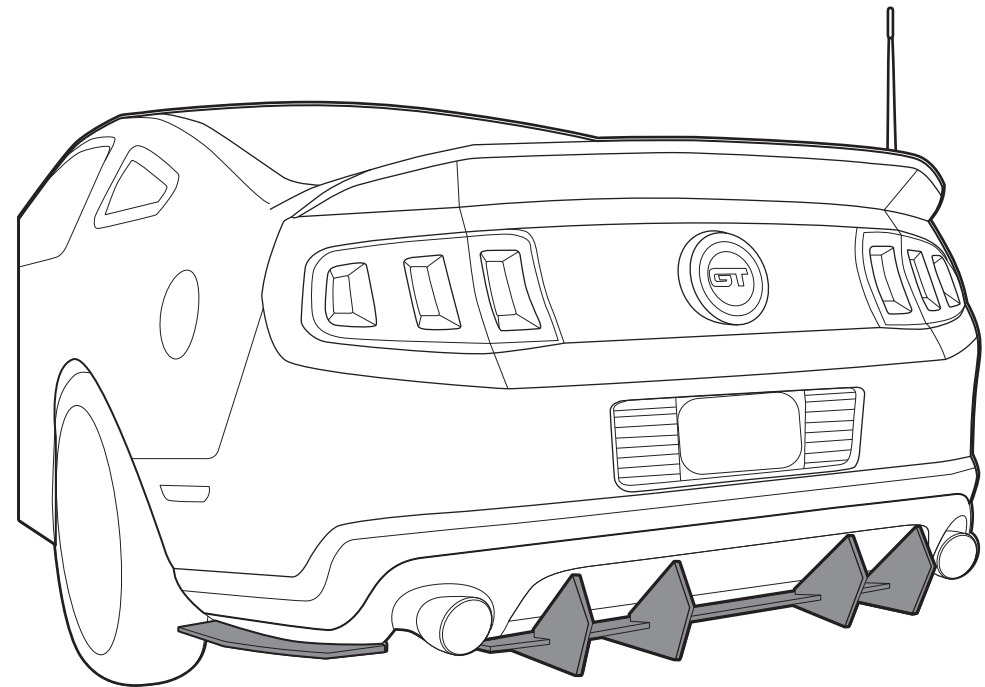

s-rda-frd-05

www.streetaero.com

info@streetaero.com