

STEP: 1 Assemble Rear Diffuser

Carefully place Fin 1, 2, 3, and 4 onto the Main Panel
(Match the number on the Fin to the number on the Main Panel)

Secure with Small Bolt and Small Nut

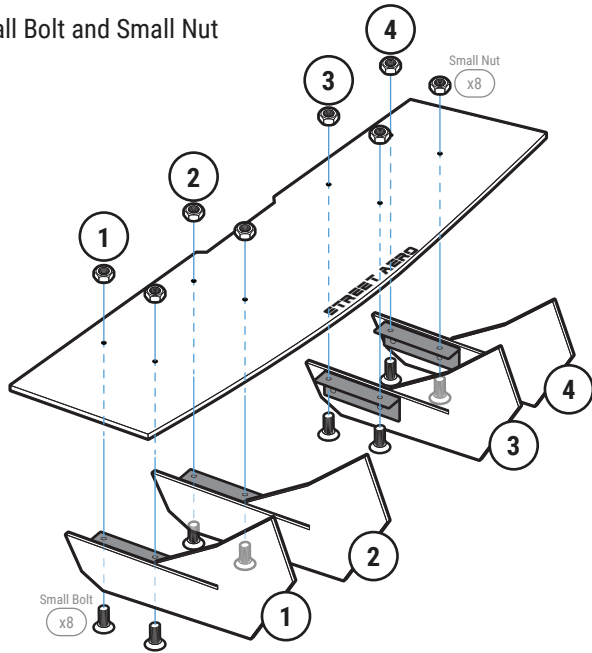

STEP: 2 Pre-drill

Align the assembled Main Panel to the bumper

Use the mounting holes on the Main Panel to mark and pre-drill into the bumper
NOTE: Pre-drill 2 more holes on the left and right side where the bumper is in contact with the Main Panel
NOTE: Main Panel may need to be removed before pre-drilling

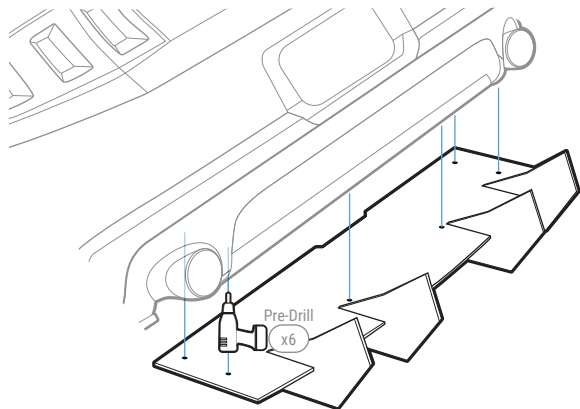

STEP: 3 Install Main Panel

Align the Rear Diffuser to the bumper

NOTE: Use the two mounting holes on the Main Panel to align the Rear Diffuser to the bumper

Mount the assembled Main Panel to the bumper by securing 1.75" Spacer with M6 70mm Bolt, Finishing Washer, Washer, and Nut

NOTE: Reach under to place Washer and Nut inside the bumper

Continue mounting by pre-drilling through the Main Panel and into the bumper where there is the most contact

NOTE: Reach under to place Washer and Nut inside the bumper

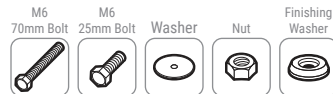
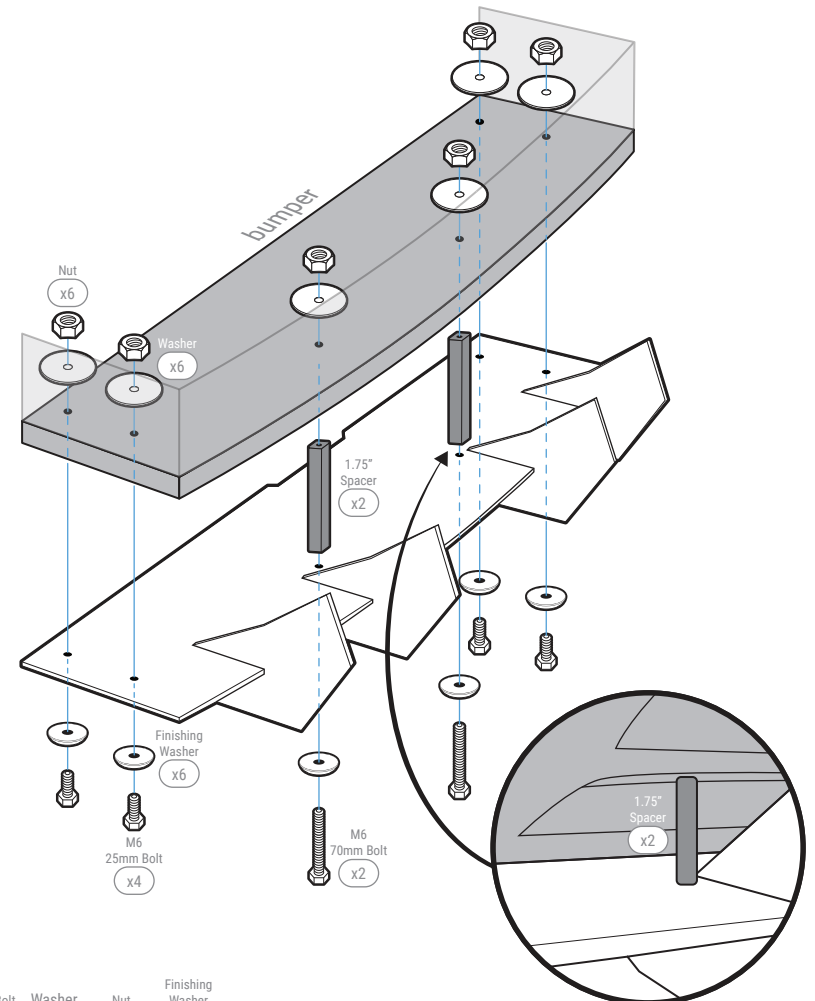

STEP: 4 *Mount Side Panel*

Position the Side Panel accordingly to the bumper

Mark where the most contact points are on the Side Panel to the bumper

Pre-drill through the Side Panel and into the bumper

Align and secure the Side Panel to the bumper with M6 25mm Bolt, Finishing Washer, Washer, and Nut

NOTE: Reach under or to the side of the bumper to place Washer and Nut inside the bumper

Repeat to install Passenger Side Panel to the bumper

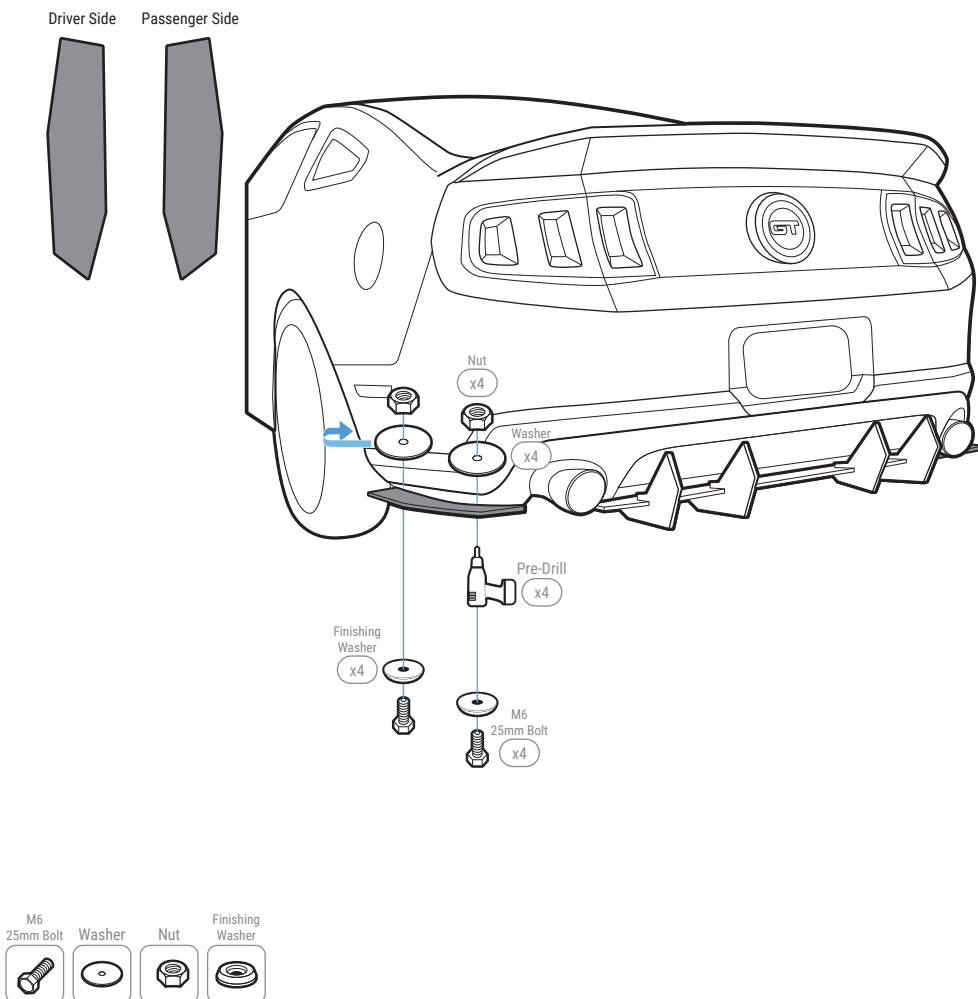

INSTALLATION GUIDE
2010-2012 Ford Mustang
Classic Edition
ACM Rear Diffuser

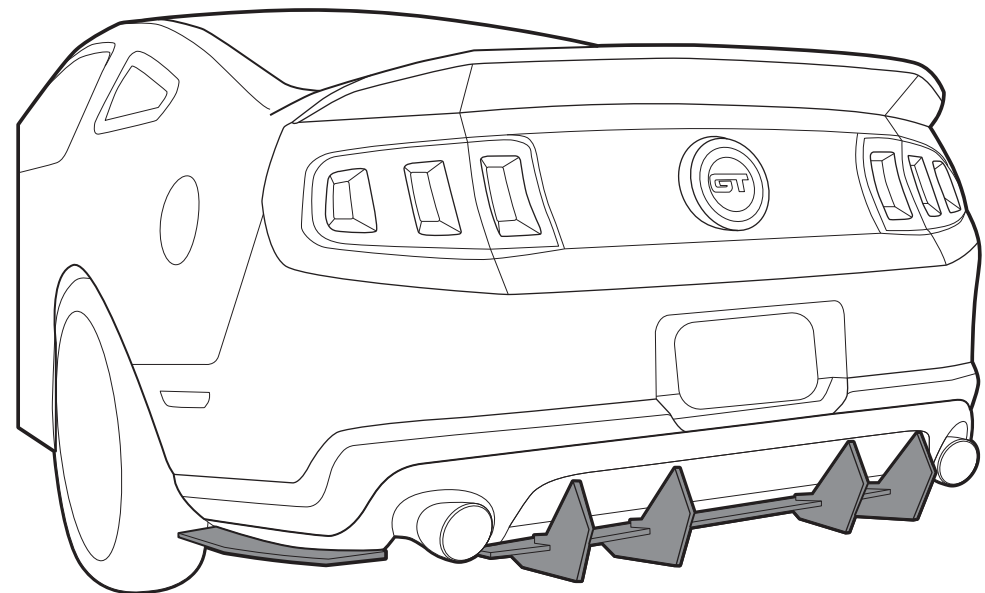

s-rda-frd-04

www.streetaero.com

info@streetaero.com