

STEP: 1 Assemble Rear Diffuser

Carefully slide Fin 1, 2, 3, and 4 onto the Main Panel
(Match the number on the Fin to the number on the Main Panel)

Secure with Small Bolt and Small Nut

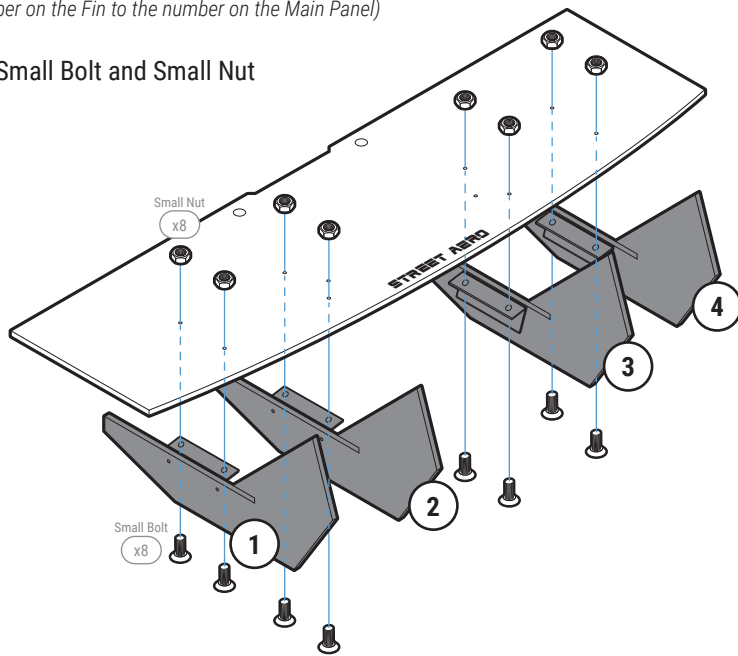

STEP: 2 Remove OEM Bolt

Remove the two OEM Bolt located under the bumper

NOTE: (Mark where the OEM Bolts are located this is where the Main Panel will be mounted)

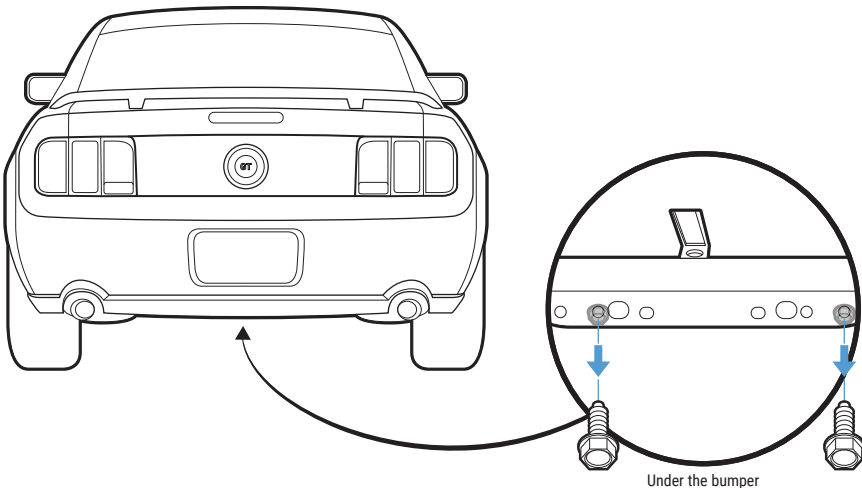

STEP: 3 Install Mounting Bracket

Use the OEM mounting holes from "STEP: 2" to mount the assembled Main Panel to the bumper with provided M6 25mm Bolt and Finishing Washer

NOTE: Reach under to place the Washer and Nut inside the bumper

Align the Main Panel as straight as possible to the bumper then use the two mounting hole as a guide to pre-drill through the bumper

Secure the Main Panel to the bumper with provided M6 25mm Bolt and Finishing Washer
NOTE: Reach under to place the Washer and Nut inside the bumper

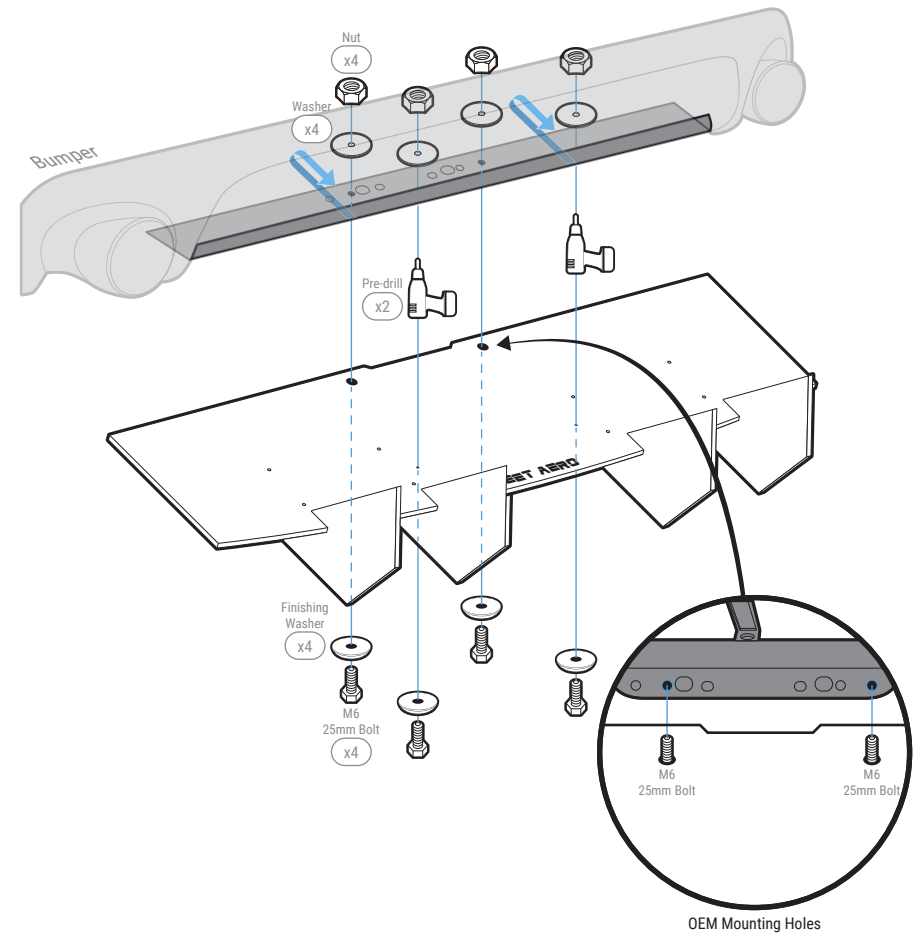

STEP: 4 *Mount the Rear Diffuser*

Attach the Side Fin to the Side Panel and secure with Small Bolt and Small Nut

Align the assembled Side Panel to the bumper and find the most contact point from the bumper to the Side Panel

Pre-drill through the Side Panel and into the bumper at the location where the Side Panel is leveled with the bumper

Attach and secure the Side Panel to the bumper with M6 25mm Bolt, Finishing Washer, Washer, and Nut

NOTE: Reach under or to the side of the bumper to place the Washer and Nut inside the bumper

Repeat to install Passenger Side Panel to the Main Panel and bumper

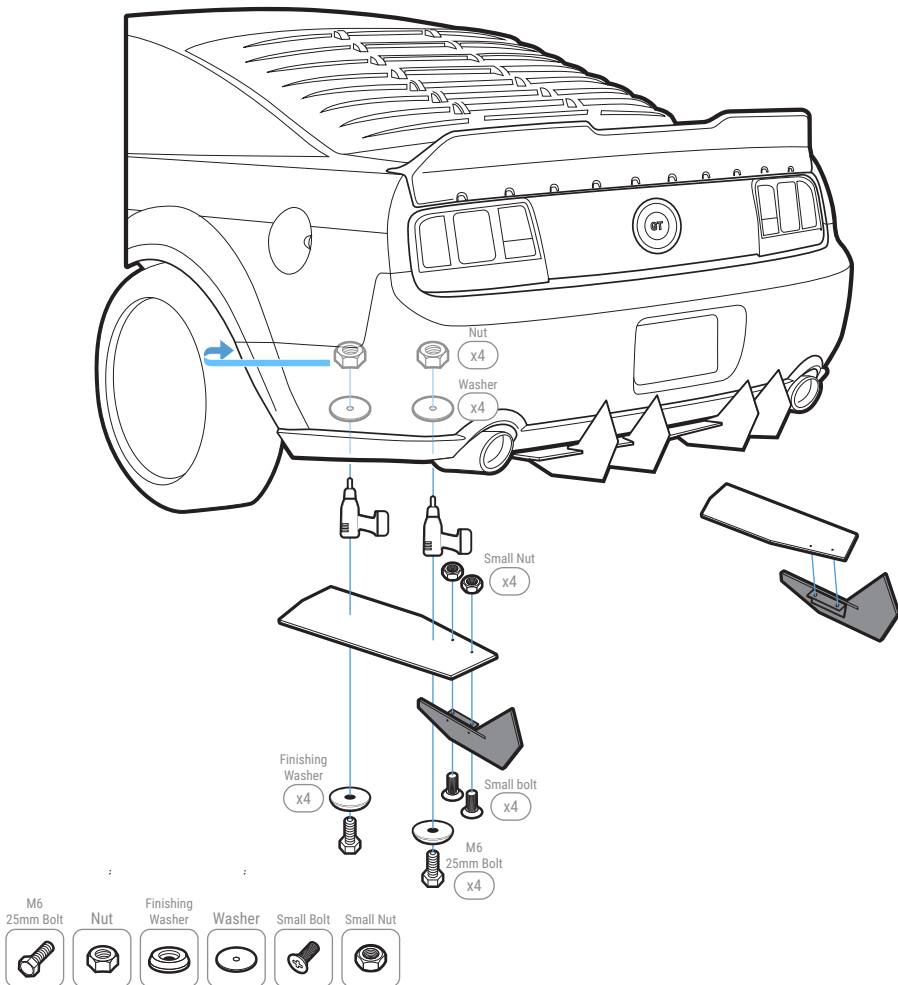

INSTALLATION GUIDE
2005-2009 Ford Mustang GT
Classic Edition
ACM Rear Diffuser

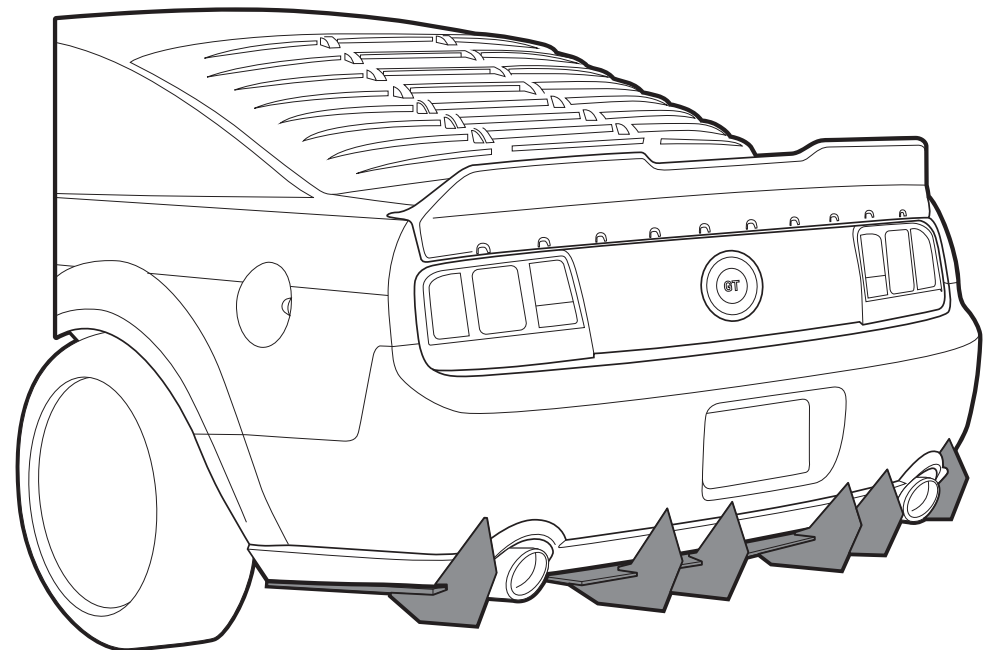

s-rda-frd-03