

STEP: 1 Assemble Rear Diffuser

Carefully place Fin 1 and Fin 2 onto the Main Panel
(Match the number on the Fin to the number on the Main Piece)

Secure with Small Bolt and Small Nut

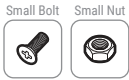
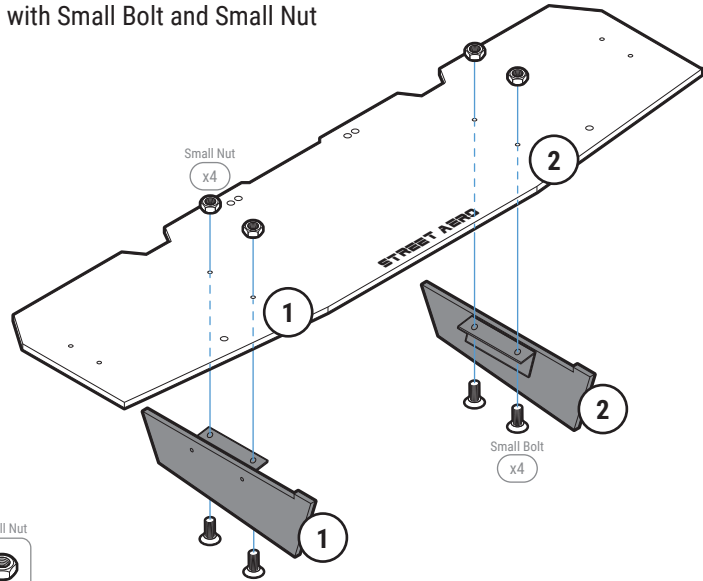

STEP: 2 Remove OEM Bolt

Remove the two OEM Bolt located under the bumper

NOTE: (Mark where the OEM Bolts are located this is where the Main Panel will be mounted)

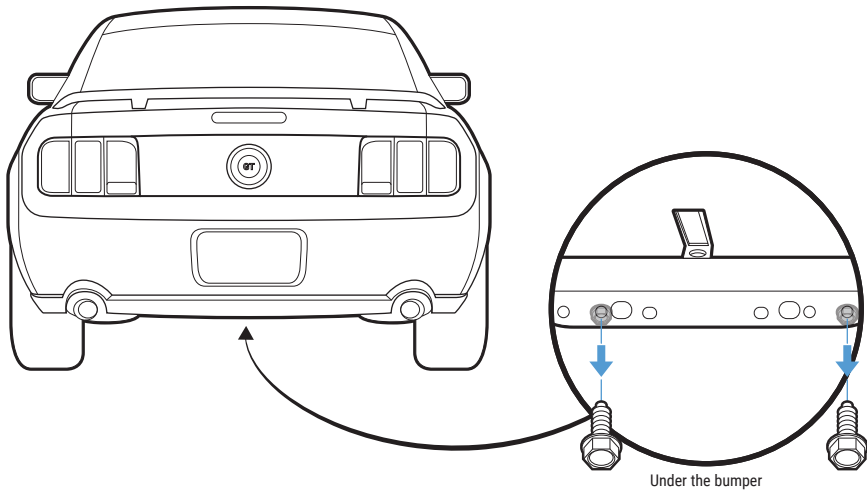

STEP: 3 Install Mounting Bracket

Use the OEM mounting holes from "STEP: 2" to mount the assembled Main Panel to the bumper with provided M6 25mm Bolt and Finishing Washer

Attach and secure both Mounting Bracket FD-48 to the Main Panel with M6 16mm Bolt, Finishing Washer, and Nut

Mark and pre-drill where both Mounting Bracket FD-48 would be mounted to the bumper

NOTE: Use the hole on top of Mounting Bracket FD-48 to mark the drill location
(Main Panel may need to be removed before pre-drilling)

Place M6 25mm Bolt into the back of Mounting Bracket FD-48

NOTE: Push the bolt all the way into the socket to prevent it from falling out

Attach the Main Panel to the bumper by securing Mounting Bracket FD-48 with M6 25mm Bolt, Washer, and Nut

NOTE: Reach behind the mounting location to secure both bolts with washer and nut

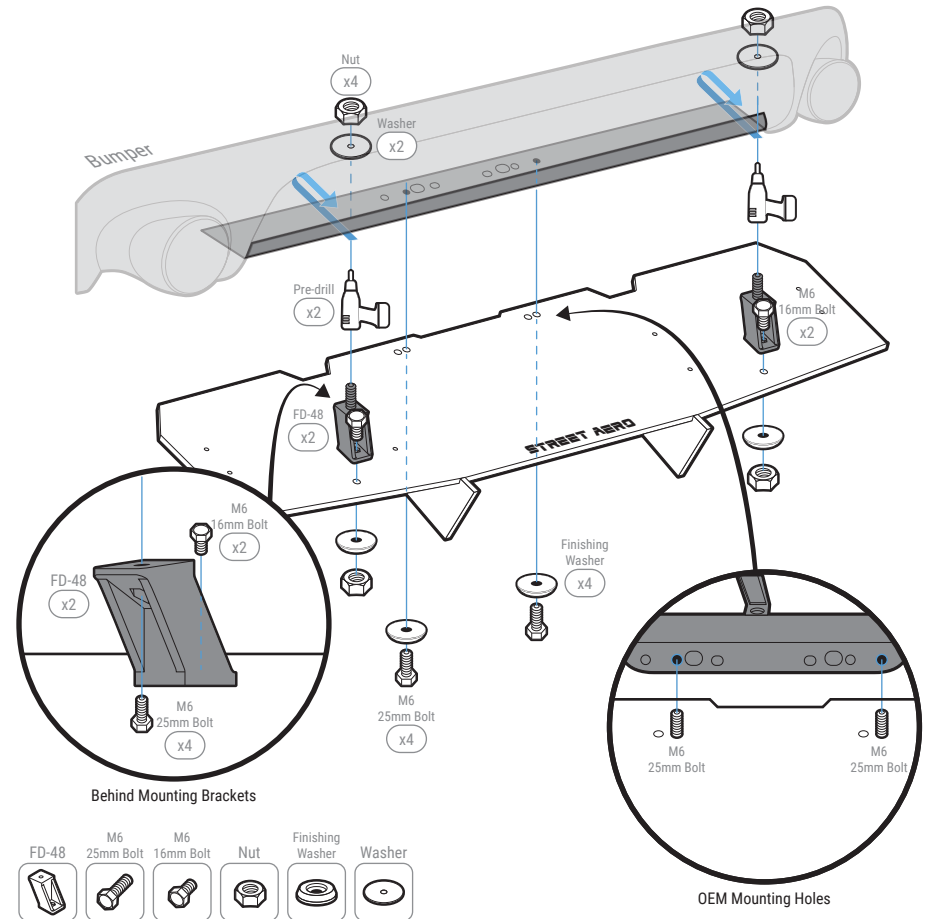

IMPORTANT: DO NOT over tighten or use power tools to mount the Mounting Brackets

STEP: 4 *Mount the Rear Diffuser*

Attach and secure Mounting Bracket FD-49 and FD-50 to the Side Panel with M6 16mm Bolt, Finishing Washer, and Nut

NOTE: Push the bolt all the way into the socket to prevent it from falling out

Attach the Side Panel to the Main Panel with Small Bolt and Small Nut

NOTE: Do Not tighten Small Bolt on the Side Panel to the Main Panel

(you will need to remove the Side Panel to pre-drill)

Mark and pre-drill where Mounting Bracket FD-49 and FD-50 would be mounted to the bumper

NOTE: Use the hole on top of Mounting Bracket FD-49 to mark the drill location

(Side Panel may need to be removed before pre-drilling)

Install the Side Panel to the Main Panel and bumper by securing Mounting Bracket FD-49 and FD-50 with provided M6 25mm Bolt, Washer, and Nut

NOTE: Use the sides near the wheels to secure the Washer and Nut inside the bumper

Repeat to install Passenger Side Panel to the Main Panel and bumper

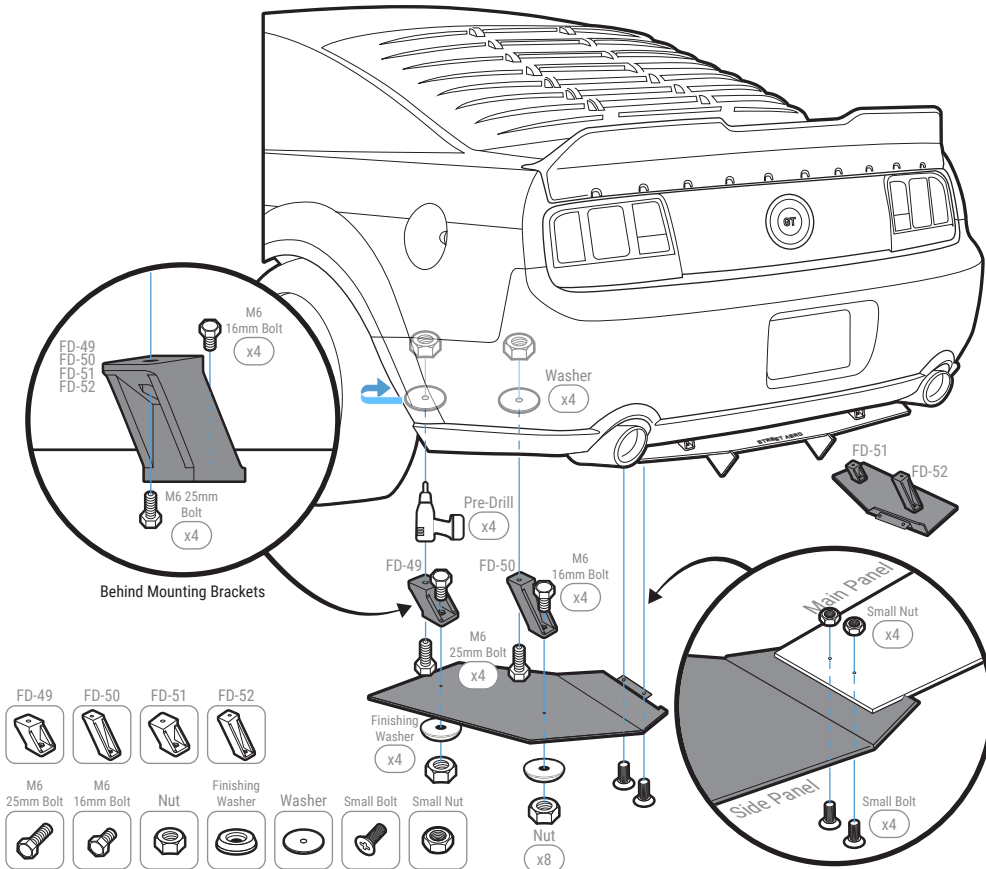

INSTALLATION GUIDE

2005-2009 Ford Mustang GT

ACM Rear Diffuser

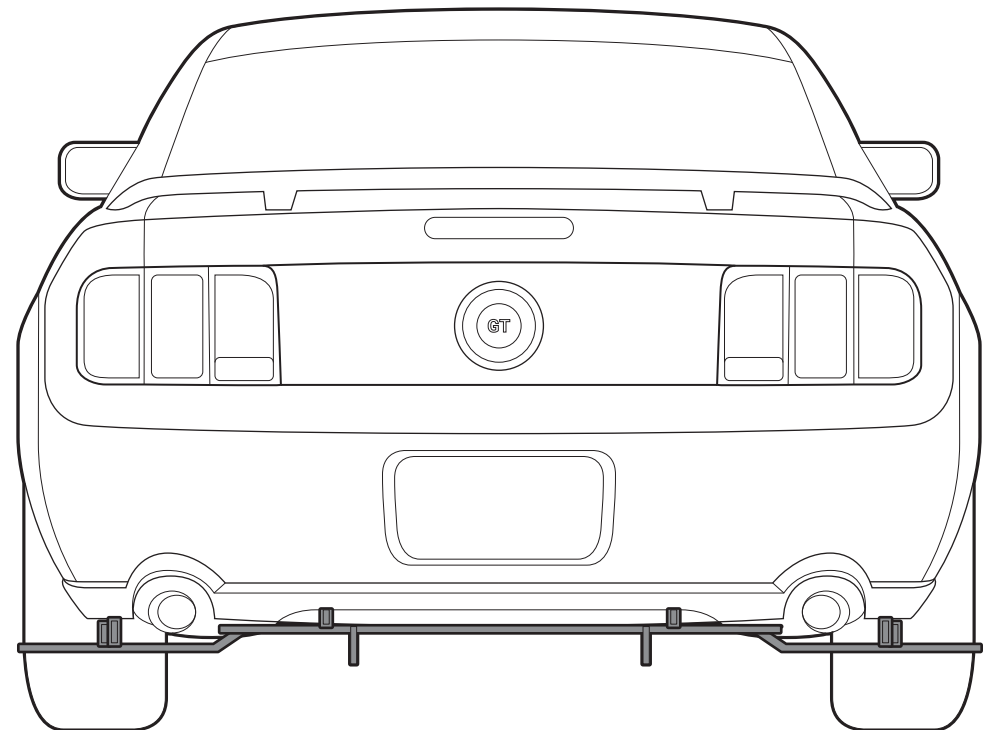

s-rda-frd-03-e1

www.streetaero.com

