

STEP: 1 *Position Jack Stand*

Position the jack stand near the back and front of the side skirt

Position the Side Splitter to the side skirt

(Street Aero Logo towards the rear bumper)

(Side Splitter should reach from one end to the other)

NOTE: Remove Mud Guards/Splash Guards if needed

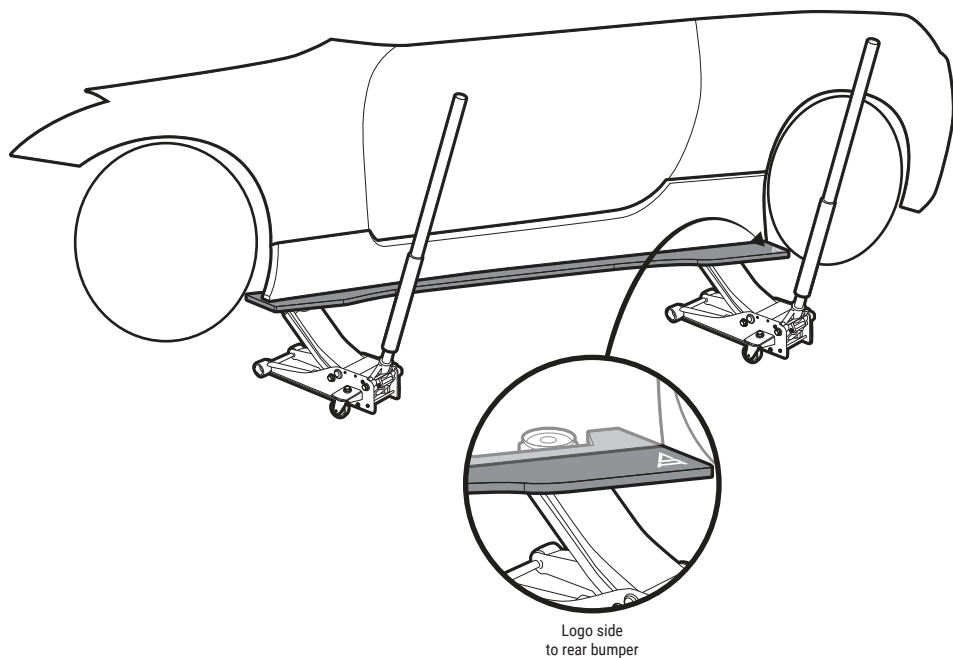

DIAGRAM *Estimated Spacing*

Use Diagram chart below for the recommended spacing of the screws/bolts

NOTE: Spacing may differ based on your side skirt

Side Splitter Size	Estimated Spacing
60-70 inches	8 inches
71-75 inches	8.5 inches
76-80 inches	9.25 inches
81-87 inches	9.8 inches

STEP: 2 *Pre-Drill*

Align the Side Splitter to a desired location

Pre-drill the side skirt and Side Splitter with **3/32"** or smaller bit size

NOTE: Keep the Side Splitter as leveled as possible while drilling

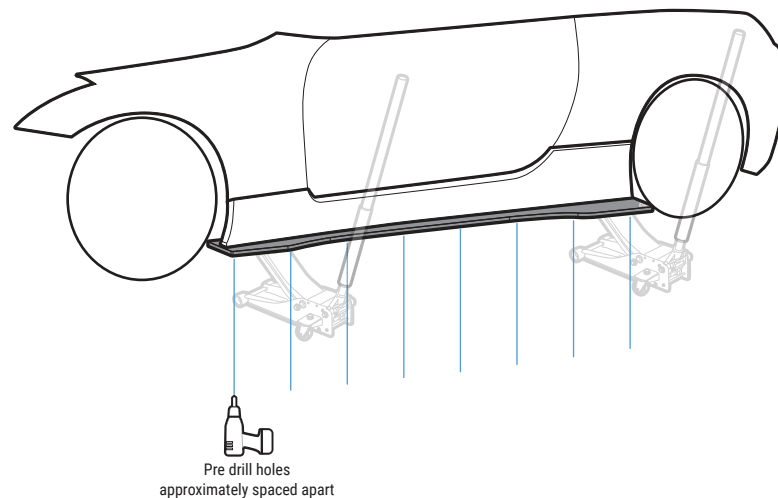

STEP: 3 *Mount Side Splitter*

Align Mounting Bracket S-3 on top of the Side Splitter where the drilled holes are

Secure the Side Splitter to the side skirt with provided Finishing Washer and Screw/Bolt

NOTE: Insert the Screw/Bolt through the Finishing Washer, Side Splitter, and Mounting Bracket S-3

NOTE: Align Mounting Bracket S-3 before Screwing into the Side Skirt

Use extra hardware if needed

Repeat for the other side

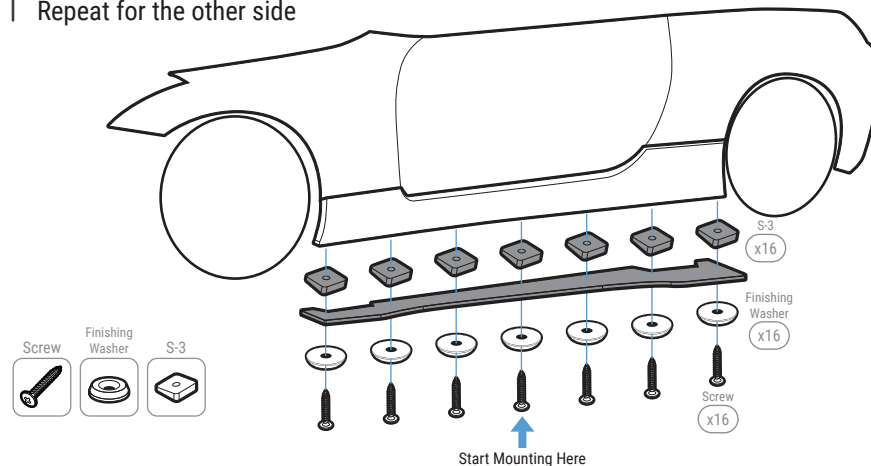

INSTALLATION GUIDE

2024 Ford Mustang

ACM Side Splitter

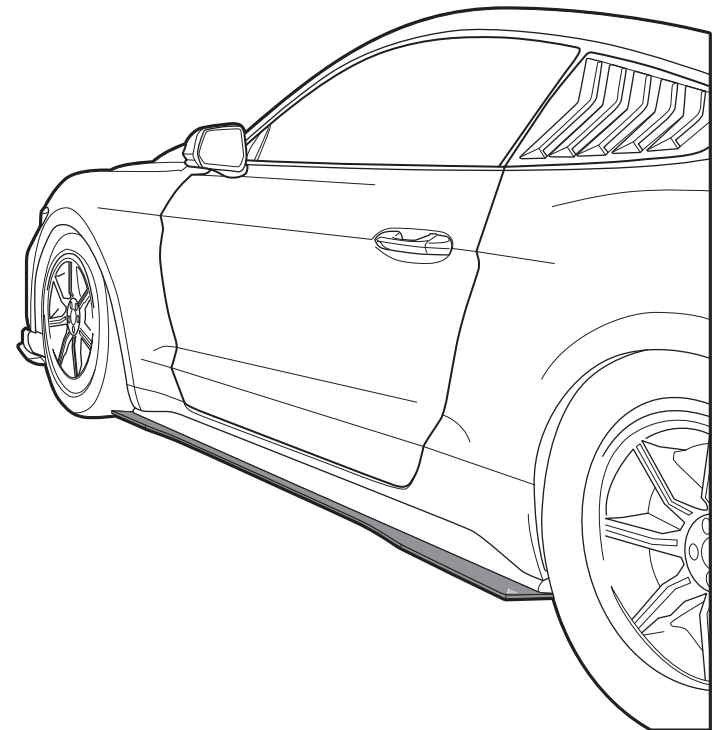
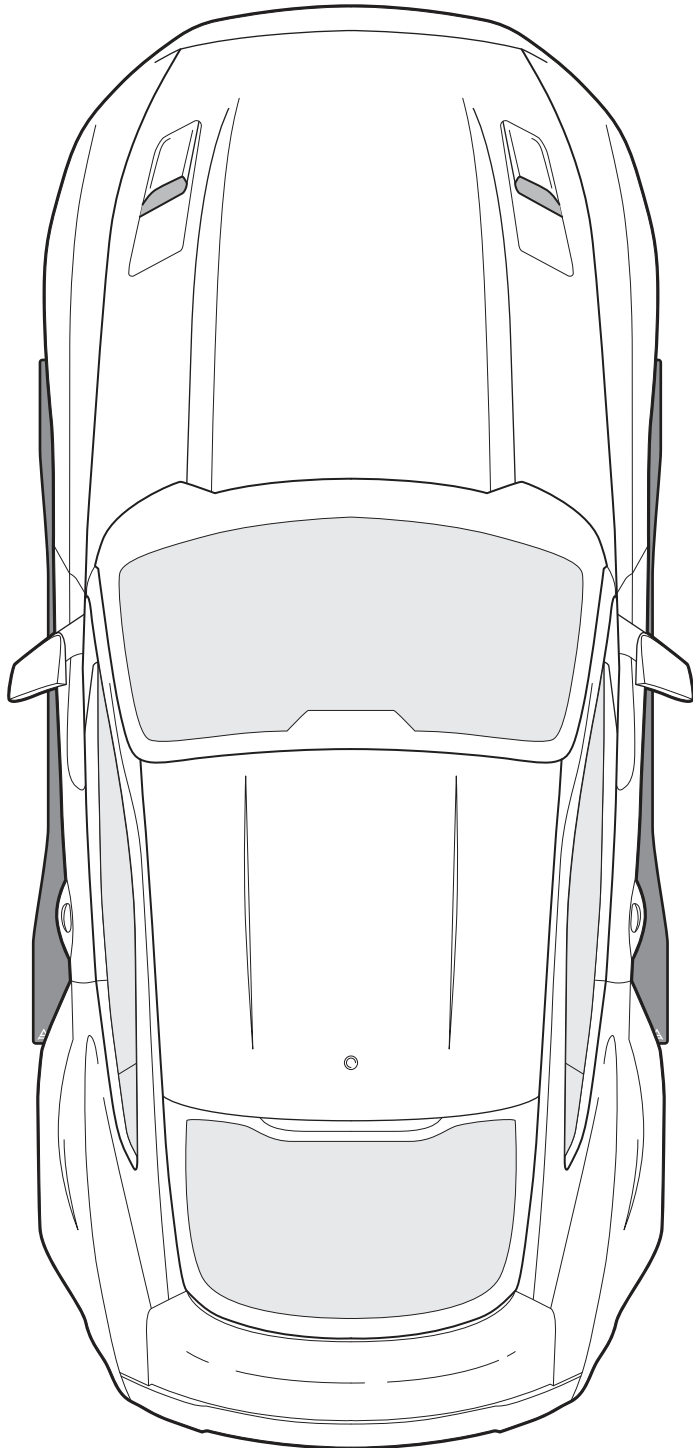

s-ssa-frd-012-cf-s75.5-s

s-ssa-frd-012-sf-s75.5-s