

**STEP: 1** Attach Side Splitter Fins

Carefully place Side Splitter Fin onto the Side Splitter  
(Logo should face outwards)

Secure with Black Screw

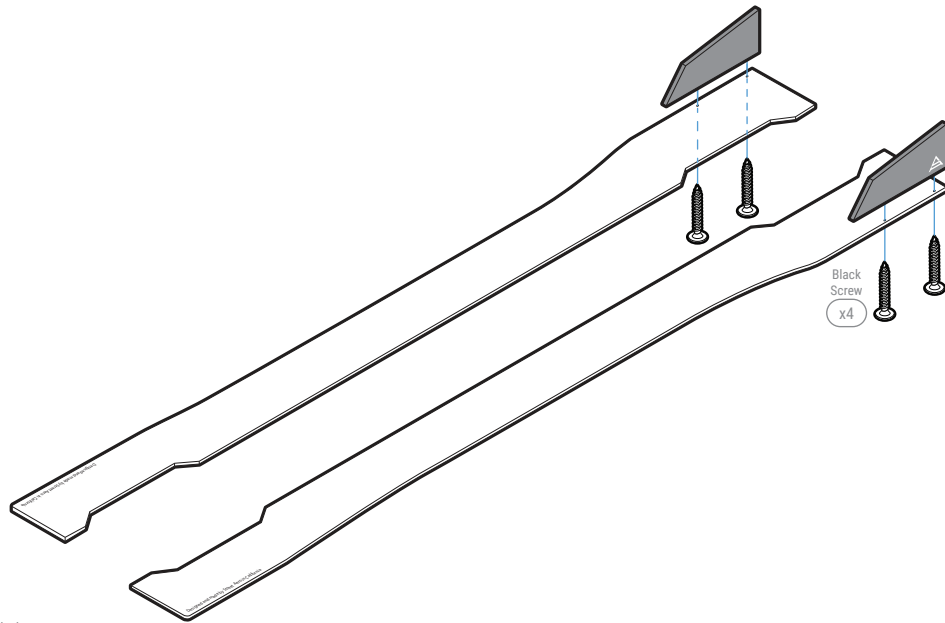

**DIAGRAM** Estimated Spacing

Use Diagram chart below for the recommended spacing of the screws/bolts  
**NOTE:** Spacing may differ based on your side skirt

| Side Splitter Size | Estimated Spacing |
|--------------------|-------------------|
| 60-70 inches       | 8 inches          |
| 71-75 inches       | 8.5 inches        |
| 76-80 inches       | 9.25 inches       |
| 81-87 inches       | 9.8 inches        |

**STEP: 2** Pre-Drill

Align the Side Splitter to a desired location

Pre-drill the side skirt and Side Splitter with **3/32"** or smaller bit size

**NOTE:** Keep the Side Splitter as leveled as possible while drilling

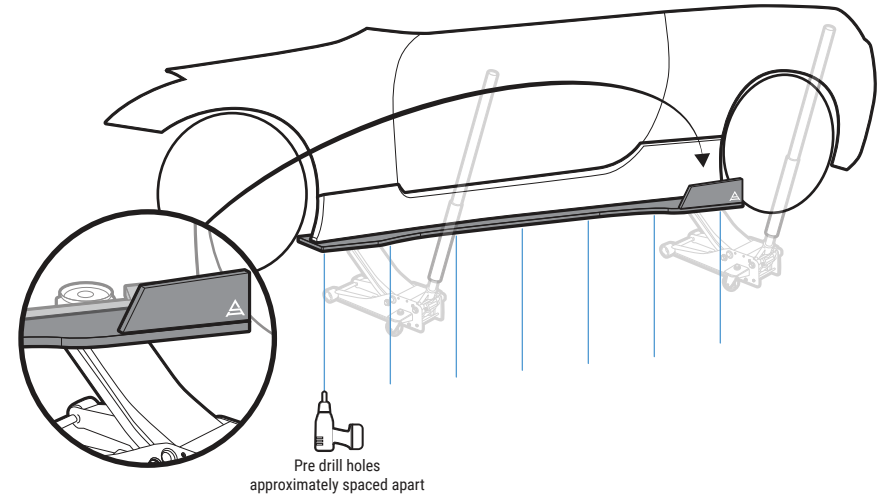

**STEP: 3** Mount Side Splitter

Align Mounting Bracket S-3 on top of the Side Splitter where the drilled holes are

Secure the Side Splitter to the side skirt with provided Finishing Washer and Screw/Bolt

**NOTE:** Insert the Screw/Bolt through the Finishing Washer, Side Splitter, and Mounting Bracket S-3

**NOTE:** Align Mounting Bracket S-3 before Screwing into the Side Skirt

Use extra hardware if needed

Repeat for the other side

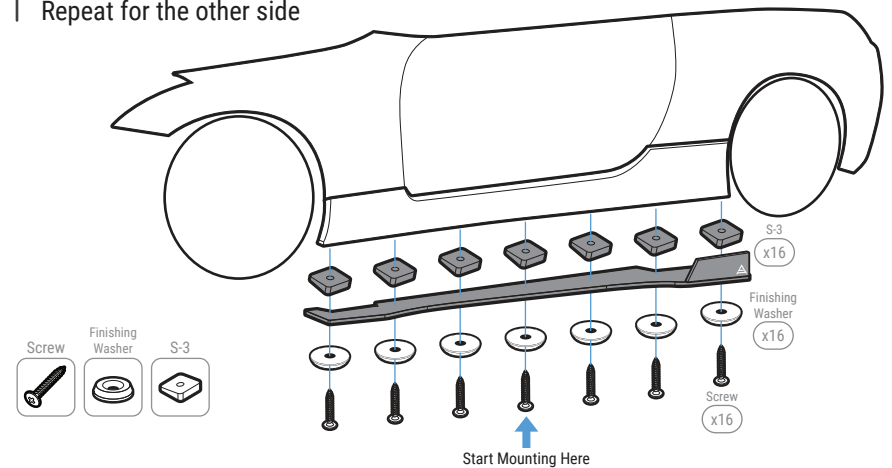

**INSTALLATION GUIDE**  
**2024 Ford Mustang**  
**ACM Side Splitter (With Fins)**

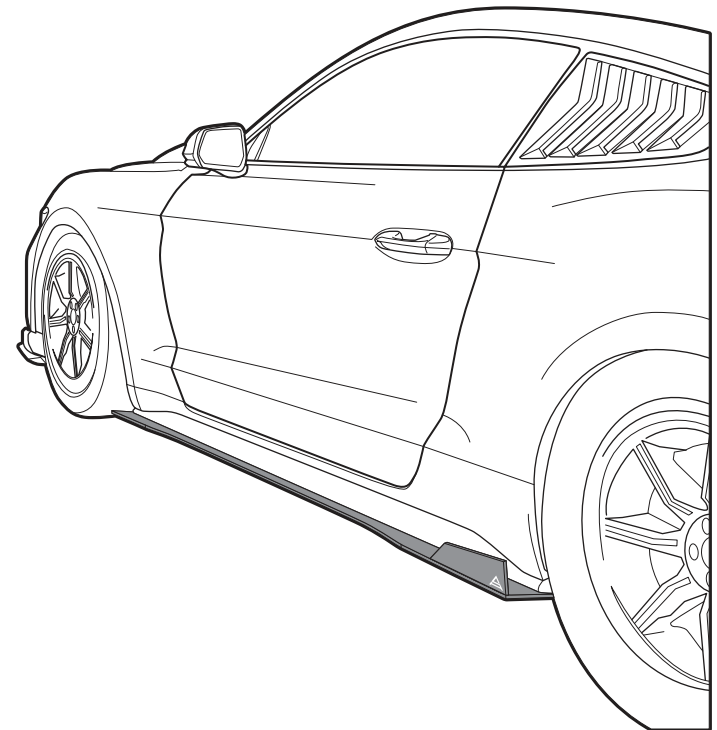
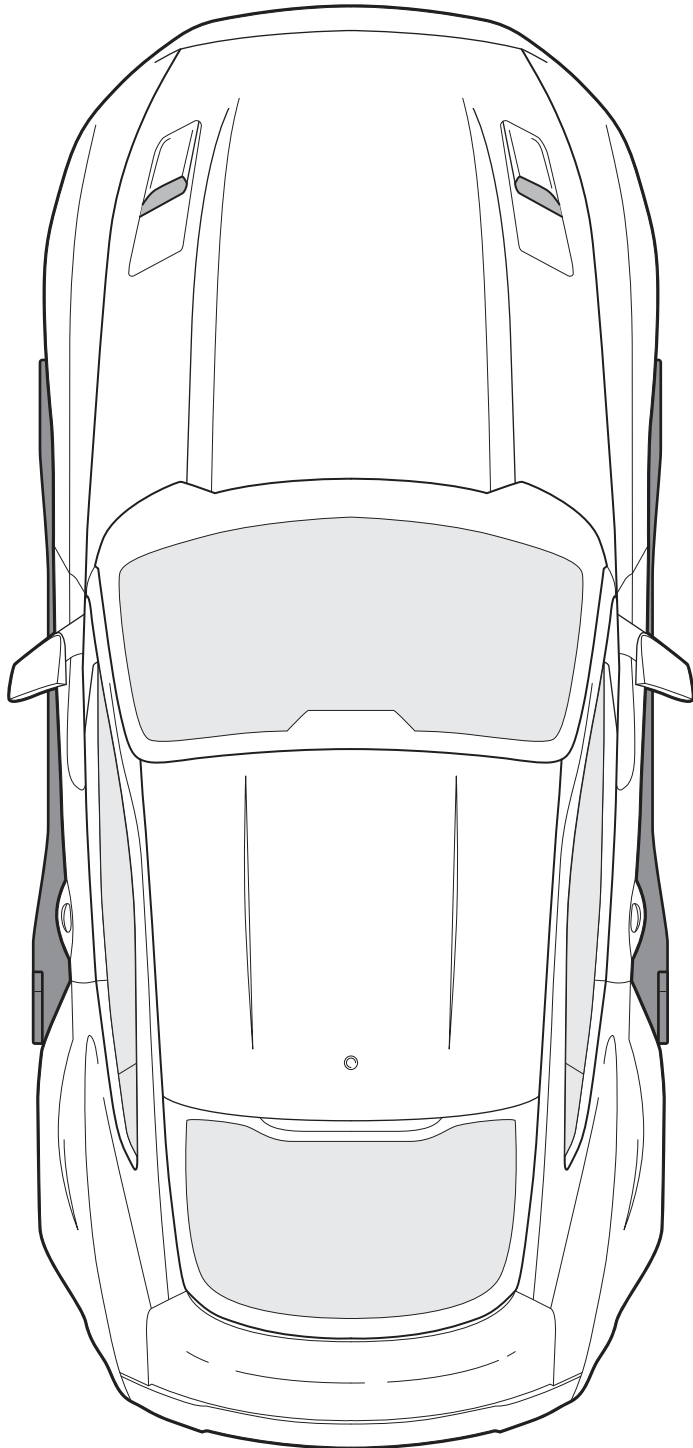

ssa-fnd-012-af-75.5s  
(With Fins)

ssa-fnd-012-af-75.5s  
(With Fins)