

STEP: 1 Assemble Main Panel

Carefully place Fin 1 and Fin 2 onto the Main Panel
(Match the number on the Fin to the number on the Main Panel)

Secure with Black Bolt and Black Nut

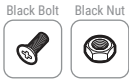
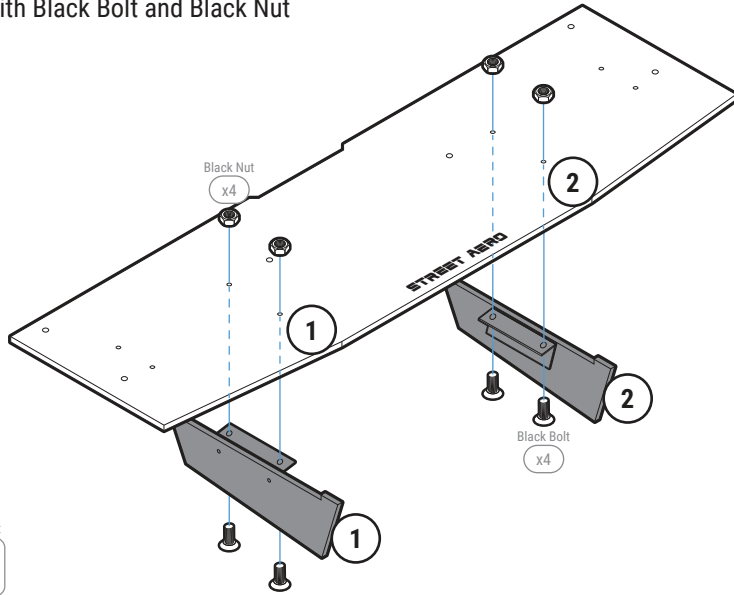

STEP: 2 Remove OEM Push Pins

Remove and replace the 2 OEM Push Pins located under the center of the bumper with provided Threaded Clips

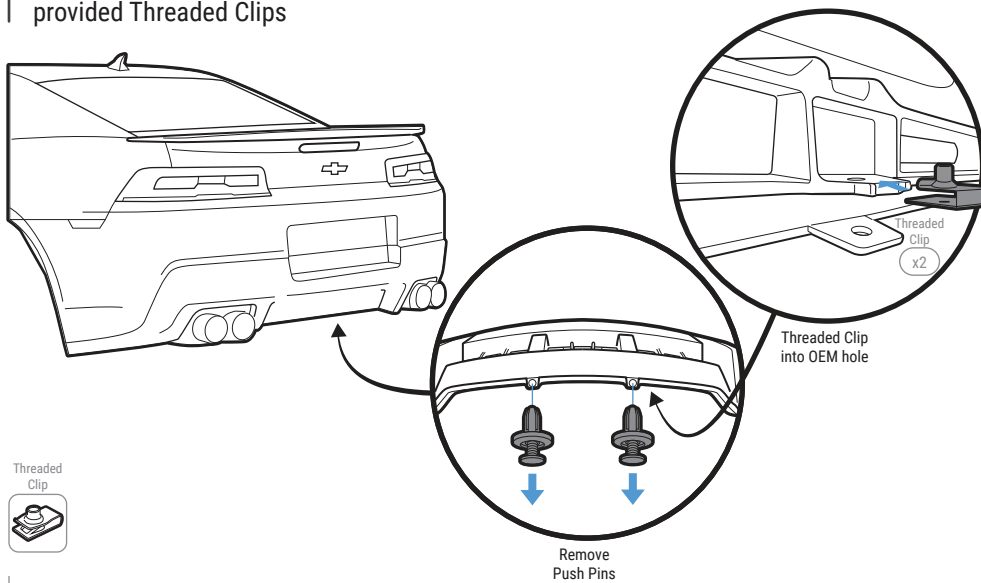

STEP: 3 Install Main Panel

Remove the 2 OEM Washer Bolt near the Exhaust under the bumper fin

Align the assembled Main Panel to the bumper by placing Mounting Brackets CT-15 to its designated mounting location and securing it with M6 55mm Bolt and Finishing Washer
NOTE: Insert the M6 55mm Bolt through the OEM mounting hole and Threaded Clip from **STEP: 2**

Mark and pre-drill into the bumper where Mounting Brackets CT-14 will be mounted
NOTE: Use the hole on top of CT-14 to mark the drill location
NOTE: Main Panel and Mounting Brackets may need to be removed before pre-drilling

Place Mounting Brackets CT-14 to its mounting location and secure it to the bumper with M6 55mm Bolt, Finishing Washer, Washer, and Nut
NOTE: Reach under or to the side of the bumper to place the Washer and Nut inside the bumper

Finishing mounting the Main Panel by securing M6 25mm to the OEM Washer Bolt hole with Finishing Washer, Washer, and Nut
NOTE: Reach under or to the side of the bumper to place the Washer and Nut inside the bumper

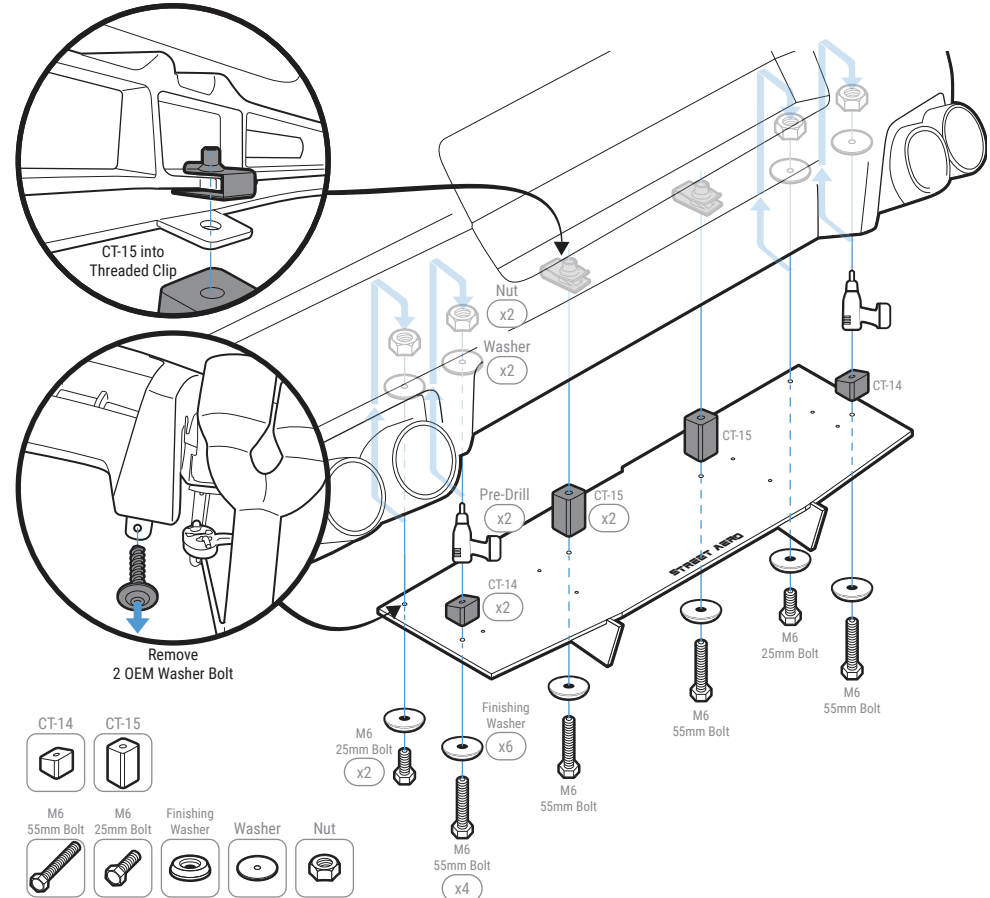

STEP: 4 *Mount the Rear Diffuser*

Attach the Side Panel to the Main Panel with Black Bolt and Black Nut

NOTE: Do not over tighten bolt and nut Side Panel will need to be removed before pre-drilling

NOTE: We also recommend removing the Splash Guard to get access behind the bumper

Align Mounting Bracket CT-16 and CT-17 to its mounting location

NOTE: Position the Mounting Brackets so it is flushed with the Side Panel and bumper

Mark and pre-drill into the bumper where the Mounting Brackets will be mounted

NOTE: Use the hole on top of the Mounting Brackets to mark the drill location

NOTE: Side Panel and Mounting Bracket may need to be removed before drilling

Secure Mounting Bracket CT-16 to the Side Panel with M6 16mm Bolt, Finishing Washer, and Nut

NOTE: Push the Nut all the way into the socket on the Mounting Bracket to prevent it from falling out

Mount the Side Panel to the bumper by securing Mounting Bracket CT-16 with M6 25mm Bolt, Washer, and Nut

NOTE: Place the M6 25mm Bolt into the socket behind the Mounting Bracket

NOTE: Reach under or to the side of the bumper to place the Washer and Nut inside the bumper

Continue mounting by securing Mounting Bracket CT-17 to the Side Panel and bumper with M6 55mm Bolt, Finishing Washer, Washer, and Nut

NOTE: Reach under or to the side of the bumper to place the Washer and Nut inside the bumper

Repeat to install Passenger Side Panel to the Main Panel and bumper

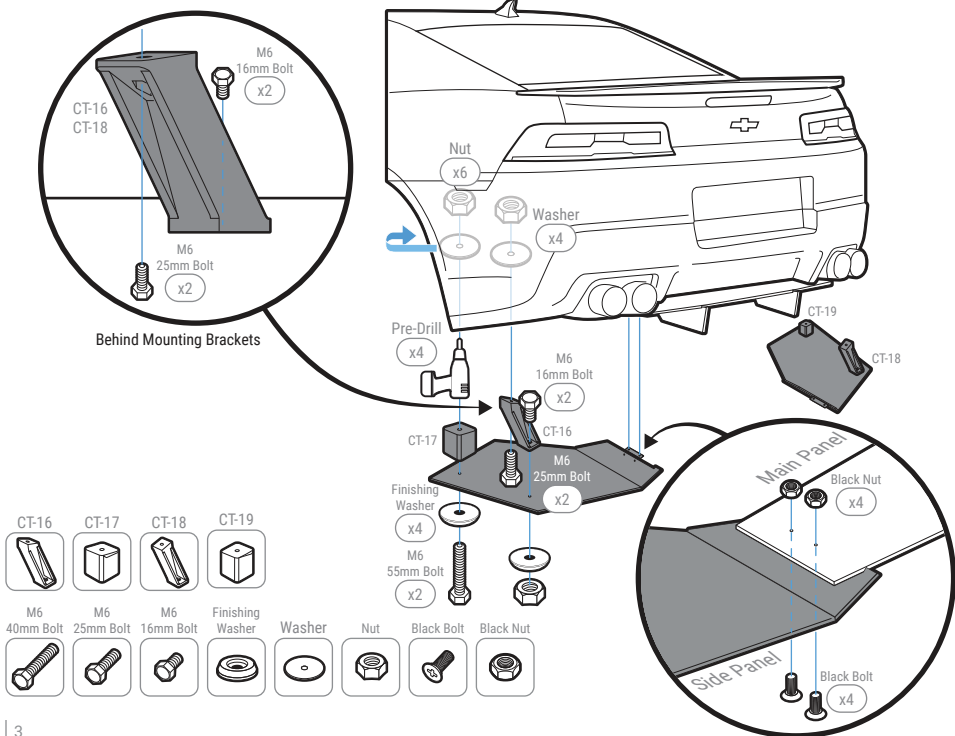

INSTALLATION GUIDE

2014-2015 Chevrolet Camaro SS

(Quad Exhaust)

ACM Rear Diffuser

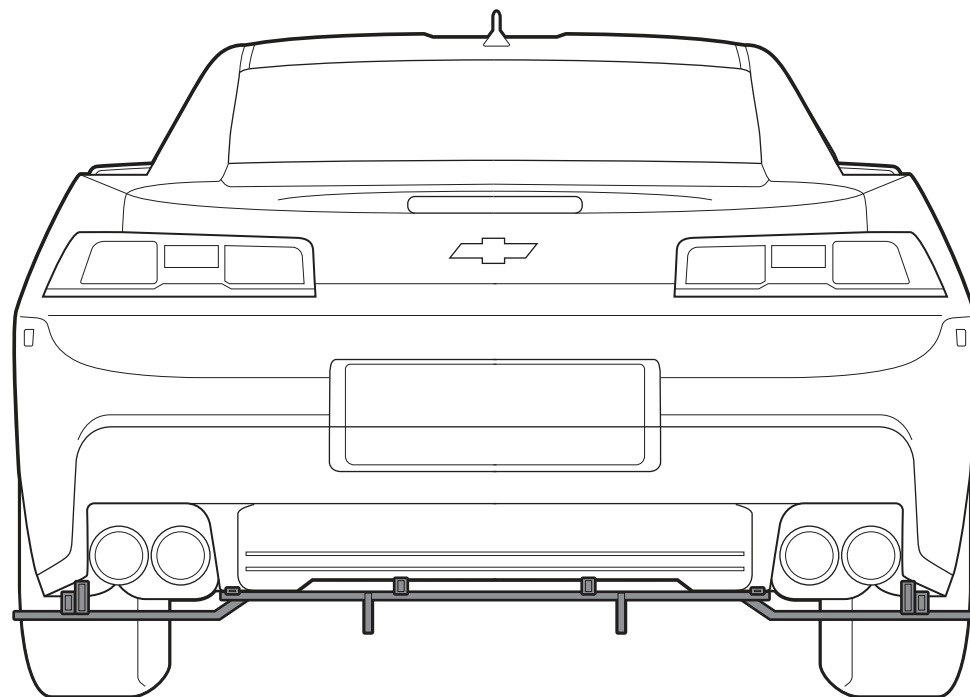

s-rda-chv-01-e1

www.streetaero.com

info@streetaero.com