

**STEP: 1** Remove Front Bumper

Remove the front bumper and undertray/undershroud from the vehicle

We recommend keeping the bumper and undertray/undershroud bolted together

We also recommend removing the splash guards

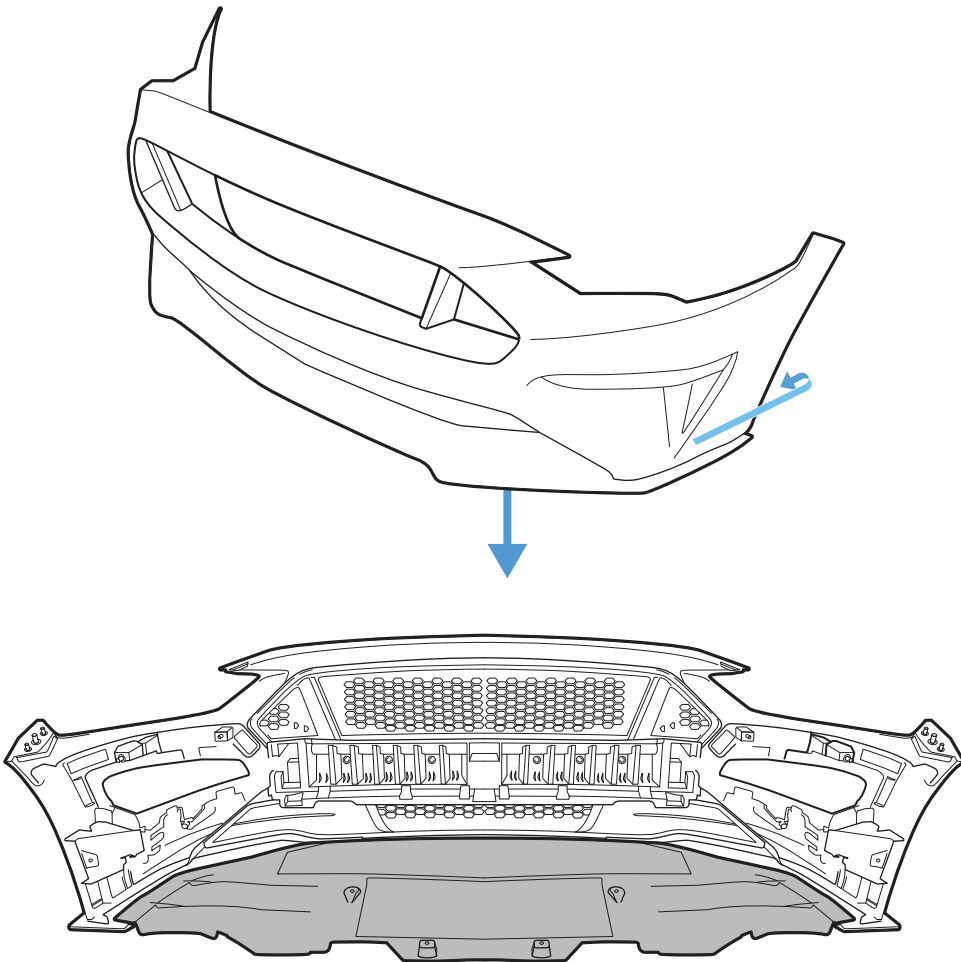

**STEP: 2** Pre-Drill

Position the bumper on top of the Front Splitter

Pre-drill through the bumper and Front Splitter to create mounting holes

We recommend drilling as close to the front of the bumper as possible

**NOTE:** Use as many OEM holes as possible

**IMPORTANT:** Bumper/Undershroud/Valence must be mounted to the chassis to support the Splitter Weight

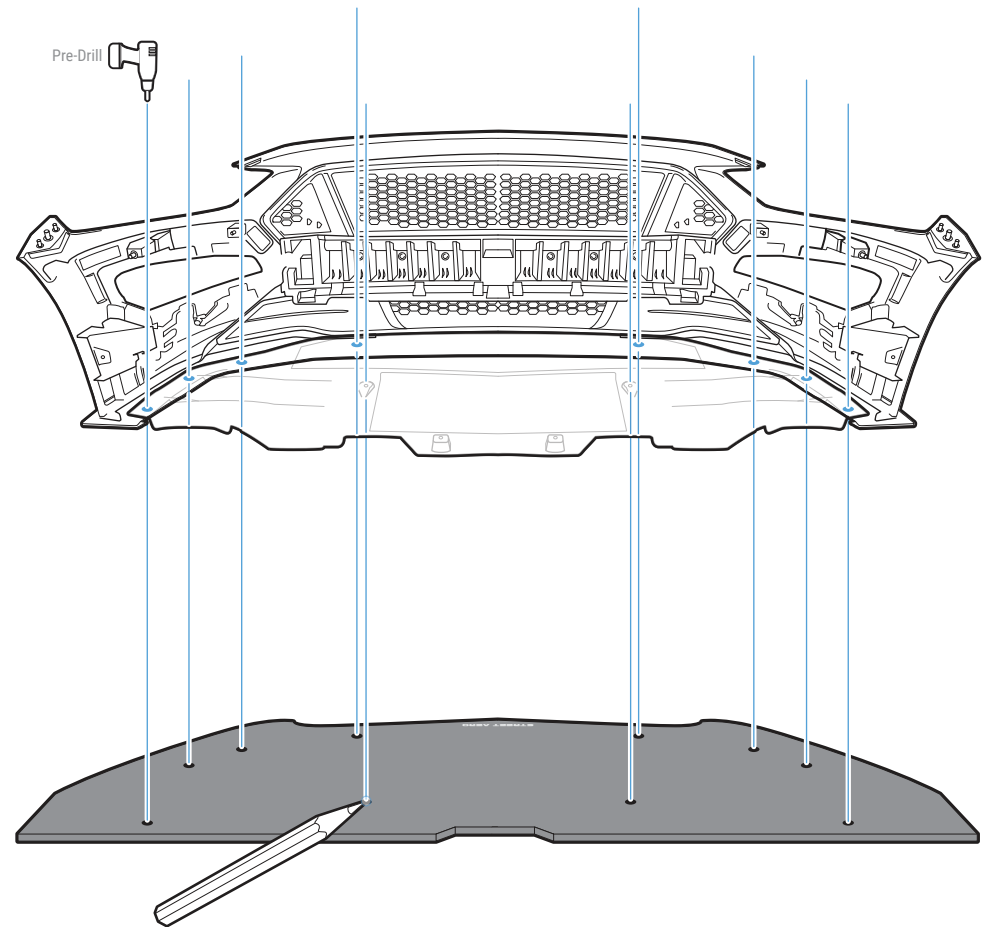

### STEP: 3 *Mount Front Splitter*

Use provided hardware to mount the Front Splitter to the front bumper

Mount the assembled bumper/shroud/Front Splitter to the vehicle

**NOTE:** Use as many hardware as needed to secure the Front Splitter to the bumper

**IMPORTANT:** The assembled Front Splitter Bumper must be bolted to the under-frame  
(use brackets to secure the Front Splitter to the frame for extra support)

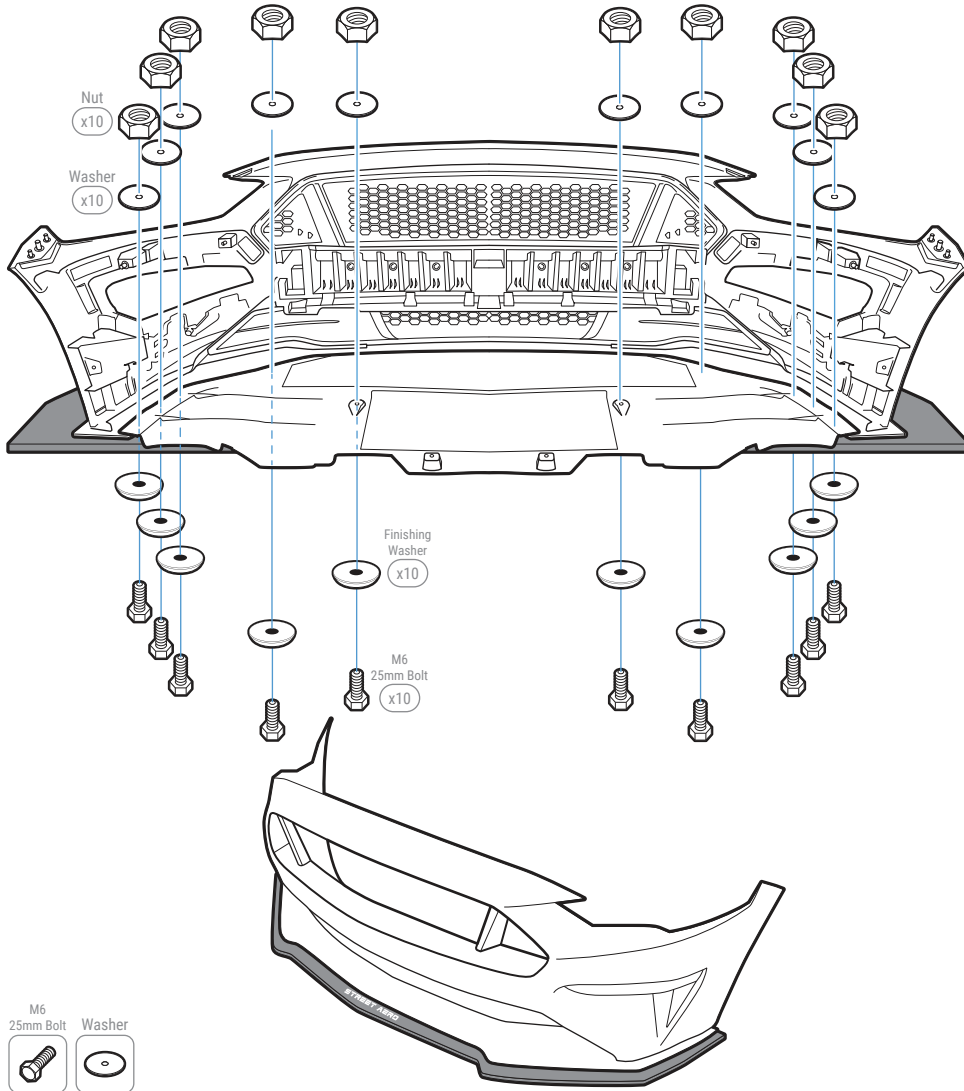

#### DISCLAIMER:

Splitter Rods (**not included**) is recommended for high speed use

#### WARNING:

Use brackets (**not included**) if your bumper is not bolted to the under-frame



## INSTALLATION GUIDE

### General

### ACM Front Splitter

#### General Instruction

Every Front Splitter is slightly different, these are **General Instructions** to use as a reference on how to mount and install your Front Splitter

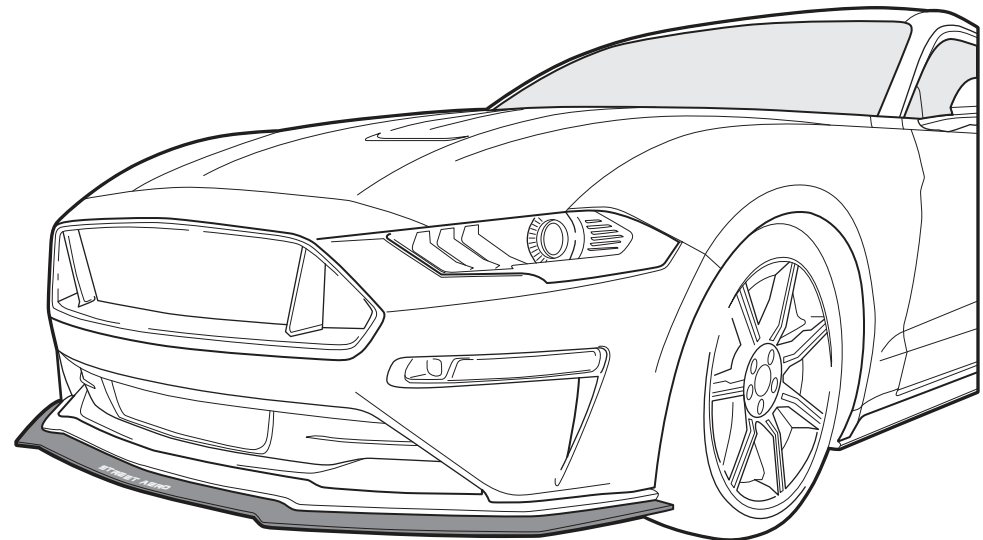

Front Splitter

[www.streetaero.com](http://www.streetaero.com)

[info@streetaero.com](mailto:info@streetaero.com)