

STEP: 1 *Attach Side Splitter Fins*

Carefully place Side Splitter Fin onto the Side Splitter
(Logo should face outwards)

Secure with Black Screw

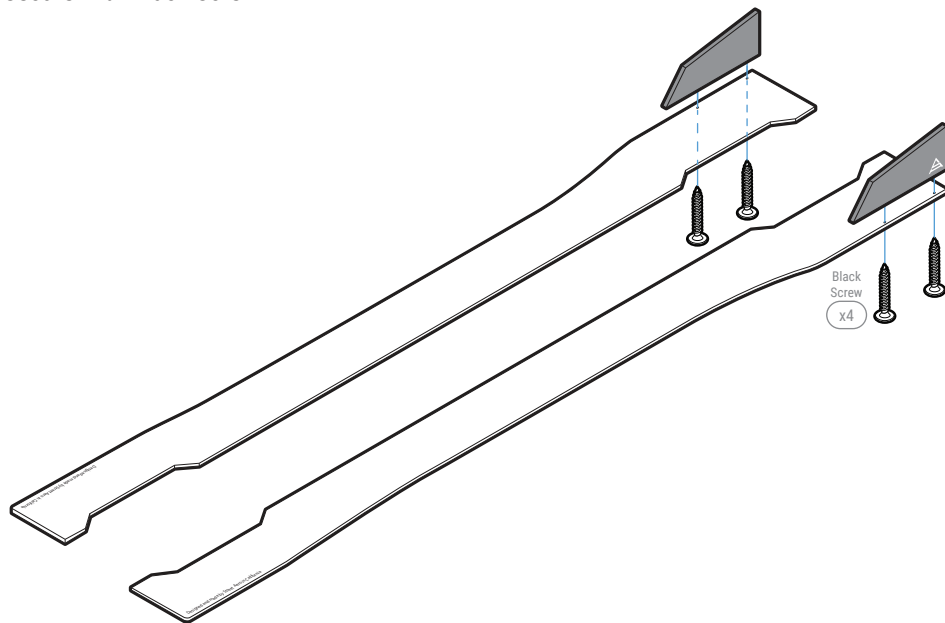

DIAGRAM *Estimated Spacing*

Use Diagram chart below for the recommended spacing for pre-drilling the Screws on **STEP: 2**

NOTE: Spacing may differ based on your side skirt

Side Splitter Size	Estimated Spacing
60-70 inches	8 inches
71-75 inches	8.5 inches
76-80 inches	9.25 inches
81-87 inches	9.8 inches

STEP: 2 *Pre-Drill*

Position the jack stand near the back and front of the side skirt

Position the Side Splitter to the side skirt
(Street Aero Logo towards the rear bumper)

(Side Splitter should reach from one end to the other)

NOTE: Remove Mud Guards/Splash Guards if needed

Pre-drill the side skirt and Side Splitter with **3/32"** or smaller bit size

Amount of screws needed varies on Side Splitter size

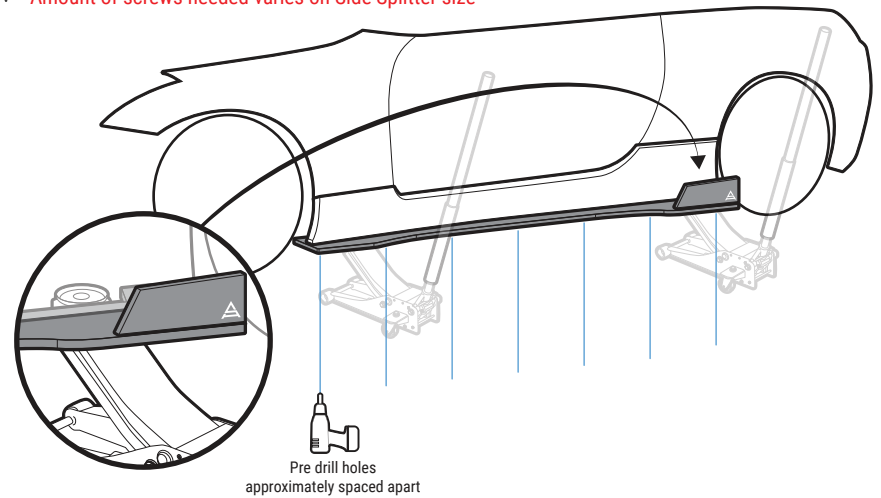

STEP: 3 *Mount Side Splitter*

Secure the Side Splitter to the side skirt with provided finishing washer and screw
(Start from the center outwards)

Use extra hardware if needed

Amount of screws needed varies on Side Splitter size

Repeat for the other side

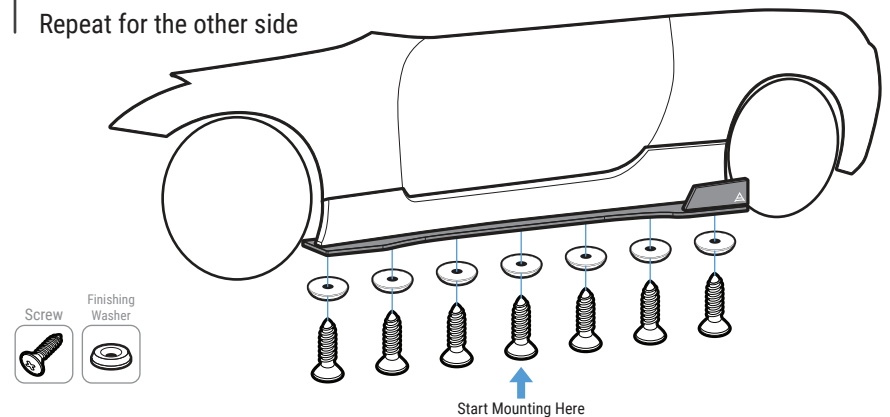

INSTALLATION GUIDE

All General ACM Side Splitter (With Fins)

General Instruction

Every Side Splitter is slightly different, these are **General Instructions** to use as a reference on how to mount and install your Side Splitter (With Fins)

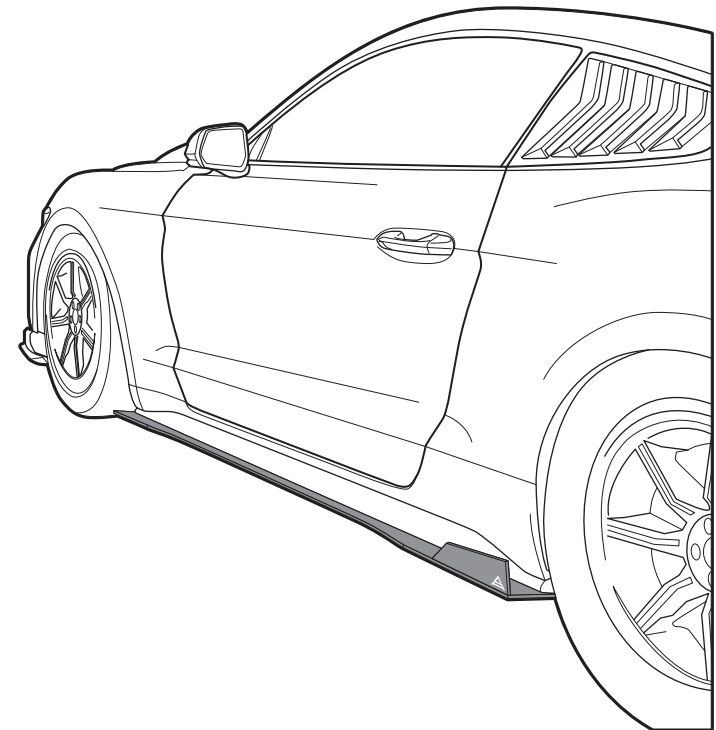
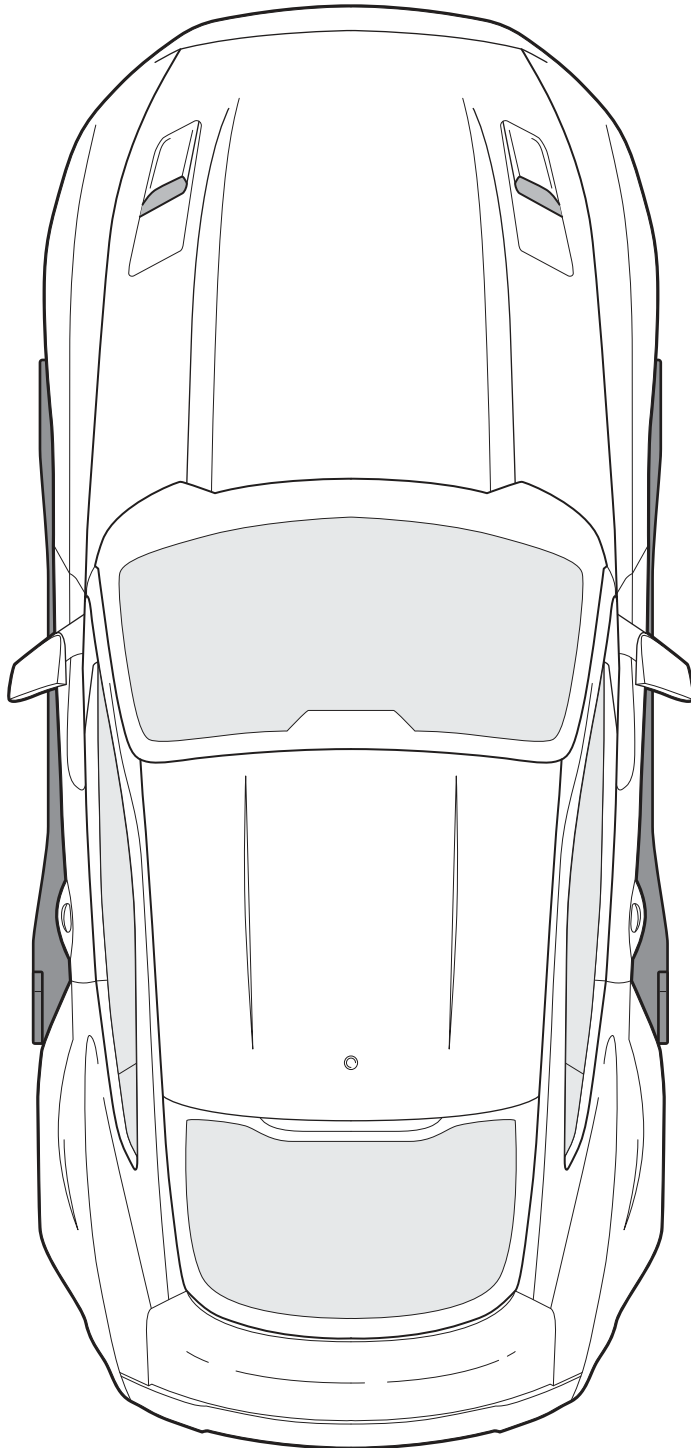

Straight Faded
(With Fins)

Cross Faded
(With Fins)