



PROFESSIONAL DIGITAL TWO-WAY RADIO

MOTOTRBO™ MOBILE

XPR™ 5350 NUMERIC DISPLAY MOBILE (WITH BLUETOOTH & GPS)

XPR™ 5550 COLOR DISPLAY MOBILE (WITH BLUETOOTH & GPS)

BASIC SERVICE MANUAL



Foreword

This manual covers all XPR™ 5000 Series Mobiles, unless otherwise specified. It includes all the information necessary to maintain peak product performance and maximum working time, using levels 1 and 2 maintenance procedures. This level of service goes down to the board replacement level and is typical of some local service centers, Motorola Authorized Dealers, self-maintained customers, and distributors.



These servicing instructions are for use by qualified personnel only. To reduce the risk of electric shock, do not perform any servicing other than that contained in the Operating Instructions unless you are qualified to do so. Refer all servicing to qualified service personnel.

Product Safety and RF Exposure Compliance



Before using this product, read the operating instructions for safe usage contained in the Product Safety and RF Exposure booklet enclosed with your radio.

ATTENTION!

This radio is restricted to occupational use only to satisfy FCC RF energy exposure requirements. Before using this product, read the RF energy awareness information and operating instructions in the Product Safety and RF Exposure booklet enclosed with your radio (Motorola Publication part number 6881095C99) to ensure compliance with RF energy exposure limits.

For a list of Motorola-approved antennas, and other accessories, visit the following web site which lists approved accessories: <http://www.motorolasolutions.com/governmentandenterprise>

Computer Software Copyrights

The Motorola products described in this manual may include copyrighted Motorola computer programs stored in semiconductor memories or other media. Laws in the United States and other countries preserve for Motorola certain exclusive rights for copyrighted computer programs, including, but not limited to, the exclusive right to copy or reproduce in any form the copyrighted computer program. Accordingly, any copyrighted Motorola computer programs contained in the Motorola products described in this manual may not be copied, reproduced, modified, reverse-engineered, or distributed in any manner without the express written permission of Motorola. Furthermore, the purchase of Motorola products shall not be deemed to grant either directly or by implication, estoppel, or otherwise, any license under the copyrights, patents or patent applications of Motorola, except for the normal non-exclusive license to use that arises by operation of law in the sale of a product.

Document Copyrights

No duplication or distribution of this document or any portion thereof shall take place without the express written permission of Motorola. No part of this manual may be reproduced, distributed, or transmitted in any form or by any means, electronic or mechanical, for any purpose without the express written permission of Motorola.

Disclaimer

The information in this document is carefully examined, and is believed to be entirely reliable. However, no responsibility is assumed for inaccuracies. Furthermore, Motorola reserves the right to make changes to any products herein to improve readability, function, or design. Motorola does not assume any liability arising out of the applications or use of any product or circuit described herein; nor does it cover any license under its patent rights nor the rights of others.

Trademarks

MOTOROLA, MOTO, MOTOROLA SOLUTIONS and the Stylized M logo are trademarks or registered trademarks of Motorola Trademark Holdings, LLC and are used under license. All other trademarks are the property of their respective owners.

Notes

Document History

The following major changes have been implemented in this manual since the previous edition.

Edition	Description	Date
68009515001-A	Initial Release.	Dec. 2011

Notes

Table of Contents

Foreword	i
Product Safety and RF Exposure Compliance	i
Computer Software Copyrights	i
Document Copyrights	i
Disclaimer	i
Trademarks	i
 Document History	 iii
 Commercial Warranty	 xi
Limited Warranty	xi
MOTOROLA COMMUNICATION PRODUCTS	xi
I. What This Warranty Covers And For How Long	xi
II. General Provisions	xii
III. State Law Rights	xii
IV. How To Get Warranty Service	xii
V. What This Warranty Does Not Cover	xii
VI. Patent And Software Provisions	xiii
VII. Governing Law	xiii
 Chapter 1 Introduction	 1-1
1.1 Notations Used in This Manual	1-1
1.2 Radio Description	1-1
1.3 Control Head Description	1-2
1.3.1 Control Head Controls (Color Display Model)	1-2
1.3.2 Control Head Controls (Numeric Display Model)	1-3
1.4 MOTOTRBO Mobile Radio Model Numbering Scheme	1-4
1.5 VHF High Power (136–174 MHz) Model Chart	1-5
1.6 VHF Low Power (136–174 MHz) Model Chart	1-6
1.7 UHF1 High Power (403–470 MHz) Model Chart	1-7
1.8 UHF1 Low Power (403–470 MHz) Model Chart	1-8
1.9 Specifications	1-9
 Chapter 2 Test Equipment and Service Aids	 2-1
2.1 Recommended Test Equipment	2-1
2.2 Service Aids	2-2
2.3 Programming Cables	2-3
 Chapter 3 Transceiver Performance Testing	 3-1
3.1 General	3-1
3.2 Setup	3-1
3.3 Color Display Model Test Mode	3-2

3.3.1	Entering Display Radio Test Mode	3-2
3.3.2	RF Test Mode	3-2
3.3.3	Color Display Test Mode	3-3
3.3.4	LED Test Mode.....	3-3
3.3.5	Backlight Test Mode	3-3
3.3.6	Speaker Tone Test Mode	3-3
3.3.7	Earpiece Tone Test Mode	3-3
3.3.8	Audio Loopback Test Mode	3-4
3.3.9	Audio Loopback Earpiece Test Mode.....	3-4
3.3.10	Button/Knob/PTT Test Mode	3-4
3.4	Numeric Display Model Test Mode	3-4
3.4.1	Entering Display Radio Test Mode	3-4
3.4.2	RF Test Mode	3-4
3.4.3	Display Test Mode	3-5
3.4.4	LED Test Mode.....	3-5
3.4.5	Speaker Tone Test Mode	3-5
3.4.6	Earpiece Tone Test Mode	3-5
3.4.7	Audio Loopback Test Mode	3-5
3.4.8	Audio Loopback Earpiece Test Mode.....	3-5
3.4.9	Button/Knob/PTT Test Mode	3-5
Chapter 4 Radio Programming and Tuning		4-1
4.1	Introduction	4-1
4.2	Customer Programming Software Setup	4-1
4.3	AirTracer Application Tool.....	4-2
4.4	Radio Tuning Setup	4-3
Chapter 5 Disassembly/Reassembly Procedures		5-1
5.1	Introduction	5-1
5.2	Preventive Maintenance	5-1
5.2.1	Inspection	5-1
5.2.2	Cleaning Procedures	5-1
5.3	Safe Handling of CMOS and LDMOS Devices	5-2
5.4	Repair Procedures and Techniques – General.....	5-4
5.5	Disassembling and Reassembling the Radio – General.....	5-5
5.6	Radio Disassembly – Detailed	5-5
5.6.1	Control Head Removal	5-5
5.6.2	Top Cover Removal.....	5-6
5.6.3	Transceiver Board Removal	5-7
5.6.4	Disassembly of Color Display Control Head.....	5-14
5.6.5	Disassembly of Numeric Display Control Head	5-19
5.7	Radio Reassembly – Detailed.....	5-22
5.7.1	Color Display Control Head	5-22
5.7.2	Numeric Display Control Head	5-27
5.7.3	Radio Assembly.....	5-32
5.7.4	Thermal Pad Replacement Procedure	5-33
5.7.5	Transceiver Board Reassembly.....	5-35
5.7.6	Assemble Control Head to Radio Assembly.....	5-48

5.8	Exploded Mechanical Views and Parts Lists	5-50
5.8.1	Radio Assembly Exploded View and Parts List	5-50
5.8.2	Control Head Exploded Views and Parts Lists	5-52
5.9	Torque Chart.....	5-54
Chapter 6 Basic Troubleshooting		6-1
6.1	Introduction	6-1
6.1.1	High Power RF Precaution	6-1
6.2	Replacement Service Kit Procedures	6-1
6.3	Power-Up Error Codes	6-2
6.4	Operational Error Codes.....	6-2
Chapter 7 Accessories		7-1
7.1	Introduction	7-1
7.1.1	Audio	7-1
7.1.2	Speakers	7-1
7.1.3	Desktop Accessories	7-1
7.1.4	Mounting Kits.....	7-2
7.1.5	Cables	7-2
7.1.6	Antennas	7-2
7.1.7	Bluetooth	7-4
7.1.8	Miscellaneous Accessories	7-4
Appendix A Replacement Parts Ordering.....		A-1
A.1	Basic Ordering Information	A-1
A.2	Motorola Online	A-1
A.3	Mail Orders	A-1
A.4	Telephone Orders.....	A-1
A.5	Fax Orders.....	A-1
A.6	Parts Identification	A-2
A.7	Product Customer Service.....	A-2
Appendix B Motorola Service Centers.....		B-1
B.1	Servicing Information	B-1
B.2	Motorola Service Center	B-1
B.3	Motorola Federal Technical Center	B-1
B.4	Motorola Canadian Technical Logistics Center	B-1
Appendix C Limited Level 3 Servicing.....		C-1
C.1	Maintenance	C-1
C.2	Component Location and Parts List.....	C-1
Glossary.....		Glossary-1

List of Figures

Figure 1-1	Radio Control Head (Color Display Model)	1-2
Figure 1-2	Radio Control Head (Numeric Display Model)	1-3
Figure 1-3	Mobile Radio Model Numbering Scheme	1-4
Figure 2-1	Mobile Front Programming Cable HKN6184_	2-3
Figure 2-2	Mobile & Repeater Rear Programming Cable PMKN4010_	2-3
Figure 2-3	Mobile & Repeater Rear Accessory Programming and Test Cable PMKN4016_	2-3
Figure 4-1	Customer Programming Software Setup from Front Connector	4-1
Figure 4-2	Customer Programming Software Setup from Rear Accessory Connector	4-2
Figure 4-3	Customer Programming Software Setup with Test Box Connection	4-2
Figure 4-4	Radio Tuning Equipment Setup	4-3
Figure 5-1	Typical Control Head Removal	5-5
Figure 5-2	Flexible Connection Removal	5-6
Figure 5-3	Top Cover Removal (Image May Not Match Exact Product)	5-6
Figure 5-4	Expansion Board and Flex Removal (Image May Not Match Exact Product)	5-7
Figure 5-5	GPS Nameplate Removal	5-7
Figure 5-6	GPS Connector Nut Removal	5-8
Figure 5-7	GPS Cable Removal	5-8
Figure 5-8	Option Board Removal (Image May Not Match Exact Product)	5-9
Figure 5-9	Acoustic Plug Removal	5-9
Figure 5-10	Die Cast Main Shield Removal	5-10
Figure 5-11	PA Screw Removal	5-11
Figure 5-12	Accessory Connector Removal	5-11
Figure 5-13	DC Connector Retention Clip Removal	5-12
Figure 5-14	RF Connector Nut Removal	5-12
Figure 5-15	Transceiver Board Removal	5-13
Figure 5-16	Control Head Flex Removal	5-14
Figure 5-17	Volume/Channel Knob Removal	5-14
Figure 5-18	Control Head Screws and Speaker Removal	5-15
Figure 5-19	PCB Retainer Removal	5-15
Figure 5-20	Control Head Board Removal	5-16
Figure 5-21	Power Button Removal	5-16
Figure 5-22	Keypad Removal	5-17
Figure 5-23	Volume Encoder Seal and Mic Jack Seal Removal	5-17
Figure 5-24	Display Pad Gasket Removal	5-18
Figure 5-25	Color Display Removal from PCB	5-18
Figure 5-26	Control Head Flex Removal	5-19
Figure 5-27	Volume/Channel Knob Removal	5-19
Figure 5-28	Control Head Board Removal	5-20
Figure 5-29	Power Button and Keypad Removal	5-20
Figure 5-30	Speaker Removal (Optional)	5-21
Figure 5-31	Volume Encoder Seal and Mic Jack Seal Removal	5-21
Figure 5-32	Power Button Placement	5-22
Figure 5-33	Keypad Assembly	5-22
Figure 5-34	Assembly to Control Head Housing	5-23
Figure 5-35	Assembling Color Display to PCB	5-23
Figure 5-36	Assembling Mic Jack Seal and Display Pad Gasket	5-24
Figure 5-37	Assembling Control Head Board to Control Head Assembly	5-24
Figure 5-38	Assembling PCB Retainer	5-25
Figure 5-39	Assembling Speaker	5-25
Figure 5-40	Orientation of Speaker	5-26

Figure 5-41	Volume/Channel Knob Assembly.....	5-26
Figure 5-42	Power Button Placement	5-27
Figure 5-43	Keypad Assembly	5-27
Figure 5-44	Assembly to Control Head Housing.....	5-28
Figure 5-45	Assembling Mic Jack Seal	5-28
Figure 5-46	Assemble Speaker	5-29
Figure 5-47	Speaker Retainer Assembly.....	5-29
Figure 5-48	Assembling Control Head Board to Control Head Assembly.....	5-30
Figure 5-49	Screw Sequence.....	5-30
Figure 5-50	Volume/Channel Knob Assembly.....	5-31
Figure 5-51	Thermal Pads and Shield Gasketing on Chassis and Die Cast Main Shield	5-32
Figure 5-52	Chassis with Thermal Pads.....	5-32
Figure 5-53	Replacing Regulator Thermal Pads	5-33
Figure 5-54	Replacing Audio PA Thermal Pad.....	5-34
Figure 5-55	Replacing Final Driver Thermal Pad	5-34
Figure 5-56	Applying Thermal Grease	5-35
Figure 5-57	Placing the Transceiver Board in the Chassis	5-35
Figure 5-58	Inserting DC Retention Clip.....	5-36
Figure 5-59	Inserting RF Lock Washer and Nut	5-37
Figure 5-60	Screw Sequence to Compress PCB	5-37
Figure 5-61	Installing PA Screws.....	5-38
Figure 5-62	Inserting Accessory Connector	5-38
Figure 5-63	Assembling Die Cast Main Shield onto Chassis	5-39
Figure 5-64	Screw Sequence to Tighten Die Cast Main Shield	5-40
Figure 5-65	RF Connector Nut Final Torque	5-40
Figure 5-66	Acoustic Plug Installation	5-41
Figure 5-67	Inspection of Cover Assembly with Seal.....	5-41
Figure 5-68	Assembling Cover onto Chassis	5-42
Figure 5-69	GPS Cable Installation.....	5-43
Figure 5-70	GPS Cable Installation.....	5-43
Figure 5-71	Flex Connection Connectors.....	5-44
Figure 5-72	Expansion Board Assembly	5-44
Figure 5-73	GPS Nameplate Assembly.....	5-45
Figure 5-74	GPS Antenna Connector Assembly.....	5-45
Figure 5-75	Orientation of Option Board Flex to Option Board	5-46
Figure 5-76	Assemble Option Board to Radio Chassis (Image May Not Match Exact Product).....	5-46
Figure 5-77	Align Option Board to Mounting Holes.....	5-47
Figure 5-78	Assemble O-ring to Chassis (Image May Not Match Exact Product).....	5-48
Figure 5-79	Assemble Control Head to Chassis	5-48
Figure 5-80	Flex Connection Connectors.....	5-49
Figure 5-81	Radio Assembly Exploded View	5-50
Figure 5-82	Color Display Control Head Exploded View.....	5-52
Figure 5-83	Numeric Display Control Head Exploded View	5-53
Figure C-1	PCB Top Side View	C-1
Figure C-2	PCB Bottom Side View	C-2

List of Tables

Table 1-1	Radio Frequency Ranges and Power Levels	1-1
Table 2-1	Recommended Test Equipment	2-1
Table 2-2	Service Aids	2-2
Table 3-1	Initial Equipment Control Settings	3-1
Table 3-2	Front Panel Access Test Mode Displays	3-2
Table 3-3	Test Environments	3-6
Table 3-4	Test Channel Spacing	3-6
Table 3-5	Test Frequencies	3-6
Table 3-6	Transmitter Performance Checks	3-7
Table 3-7	Receiver Performance Checks	3-8
Table 4-1	Radio Software Program Kit	4-1
Table 5-1	Lead Free Solder Wire Part Number List	5-4
Table 5-2	Lead Free Solder Paste Part Number List	5-4
Table 5-3	Radio Exploded View Parts List	5-51
Table 5-4	Color Display Control Head (PMLN5678_) Exploded View Parts List	5-52
Table 5-5	Numeric Display Control Head (PMLN5677_) Exploded View Parts List	5-53
Table 5-6	Torque Specifications for Nuts and Screws	5-54
Table 6-1	Power-Up Error Codes	6-2
Table 6-2	Operational Error Codes	6-2
Table C-1.	Component Parts List	C-2

Commercial Warranty

Limited Warranty

MOTOROLA COMMUNICATION PRODUCTS

I. What This Warranty Covers And For How Long

MOTOROLA SOLUTIONS, INC. ("MOTOROLA") warrants the MOTOROLA manufactured Communication Products listed below ("Product") against defects in material and workmanship under normal use and service for a period of time from the date of purchase as scheduled below:

XPR Series Digital Mobile Radios	Two (2) Years
Product Accessories	One (1) Year

The mobiles additionally ship with a standard 1-year Repair Service Advantage (RSA)(for U.S. customers) or 1-year Extended Warranty (for Canada customers). However, at the time of order, you may choose to omit these warranties. For more RSA or Extended Warranty information, please refer to the price pages or Motorola Online (<https://www.motorola.com/businessonline>) > Resource Center > Services > Service Product Offerings > Repair Service Advantage or Extended Warranty.

Motorola, at its option, will at no charge either repair the Product (with new or reconditioned parts), replace it (with a new or reconditioned Product), or refund the purchase price of the Product during the warranty period provided it is returned in accordance with the terms of this warranty. Replaced parts or boards are warranted for the balance of the original applicable warranty period. All replaced parts of Product shall become the property of MOTOROLA.

This express limited warranty is extended by MOTOROLA to the original end user purchaser only and is not assignable or transferable to any other party. This is the complete warranty for the Product manufactured by MOTOROLA. MOTOROLA assumes no obligations or liability for additions or modifications to this warranty unless made in writing and signed by an officer of MOTOROLA. Unless made in a separate agreement between MOTOROLA and the original end user purchaser, MOTOROLA does not warrant the installation, maintenance or service of the Product.

MOTOROLA cannot be responsible in any way for any ancillary equipment not furnished by MOTOROLA which is attached to or used in connection with the Product, or for operation of the Product with any ancillary equipment, and all such equipment is expressly excluded from this warranty. Because each system which may use the Product is unique, MOTOROLA disclaims liability for range, coverage, or operation of the system as a whole under this warranty.

II. General Provisions

This warranty sets forth the full extent of MOTOROLA'S responsibilities regarding the Product. Repair, replacement or refund of the purchase price, at MOTOROLA's option, is the exclusive remedy. THIS WARRANTY IS GIVEN IN LIEU OF ALL OTHER EXPRESS WARRANTIES. IMPLIED WARRANTIES, INCLUDING WITHOUT LIMITATION, IMPLIED WARRANTIES OF MERCHANTABILITY AND FITNESS FOR A PARTICULAR PURPOSE, ARE LIMITED TO THE DURATION OF THIS LIMITED WARRANTY. IN NO EVENT SHALL MOTOROLA BE LIABLE FOR DAMAGES IN EXCESS OF THE PURCHASE PRICE OF THE PRODUCT, FOR ANY LOSS OF USE, LOSS OF TIME, INCONVENIENCE, COMMERCIAL LOSS, LOST PROFITS OR SAVINGS OR OTHER INCIDENTAL, SPECIAL OR CONSEQUENTIAL DAMAGES ARISING OUT OF THE USE OR INABILITY TO USE SUCH PRODUCT, TO THE FULL EXTENT SUCH MAY BE DISCLAIMED BY LAW.

III. State Law Rights

SOME STATES DO NOT ALLOW THE EXCLUSION OR LIMITATION OF INCIDENTAL OR CONSEQUENTIAL DAMAGES OR LIMITATION ON HOW LONG AN IMPLIED WARRANTY LASTS, SO THE ABOVE LIMITATION OR EXCLUSIONS MAY NOT APPLY.

This warranty gives specific legal rights, and there may be other rights which may vary from state to state.

IV. How To Get Warranty Service

You must provide proof of purchase (bearing the date of purchase and Product item serial number) in order to receive warranty service and, also, deliver or send the Product item, transportation and insurance prepaid, to an authorized warranty service location. Warranty service will be provided by Motorola through one of its authorized warranty service locations. If you first contact the company which sold you the Product, it can facilitate your obtaining warranty service. You can also call Motorola at 1-888-567-7347 US/Canada.

V. What This Warranty Does Not Cover

- A. Defects or damage resulting from use of the Product in other than its normal and customary manner.
- B. Defects or damage from misuse, accident, water, or neglect.
- C. Defects or damage from improper testing, operation, maintenance, installation, alteration, modification, or adjustment.
- D. Breakage or damage to antennas unless caused directly by defects in material workmanship.
- E. A Product subjected to unauthorized Product modifications, disassemblies or repairs (including, without limitation, the addition to the Product of non-Motorola supplied equipment) which adversely affect performance of the Product or interfere with Motorola's normal warranty inspection and testing of the Product to verify any warranty claim.
- F. Product which has had the serial number removed or made illegible.
- G. Freight costs to the repair depot.
- H. A Product which, due to illegal or unauthorized alteration of the software/firmware in the Product, does not function in accordance with MOTOROLA's published specifications or the FCC type acceptance labeling in effect for the Product at the time the Product was initially distributed from MOTOROLA.
- I. Scratches or other cosmetic damage to Product surfaces that does not affect the operation of the Product.
- J. Normal and customary wear and tear.

VI. Patent And Software Provisions

MOTOROLA will defend, at its own expense, any suit brought against the end user purchaser to the extent that it is based on a claim that the Product or parts infringe a United States patent, and MOTOROLA will pay those costs and damages finally awarded against the end user purchaser in any such suit which are attributable to any such claim, but such defense and payments are conditioned on the following:

- A. that MOTOROLA will be notified promptly in writing by such purchaser of any notice of such claim;
- B. that MOTOROLA will have sole control of the defense of such suit and all negotiations for its settlement or compromise; and
- C. should the Product or parts become, or in MOTOROLA's opinion be likely to become, the subject of a claim of infringement of a United States patent, that such purchaser will permit MOTOROLA, at its option and expense, either to procure for such purchaser the right to continue using the Product or parts or to replace or modify the same so that it becomes noninfringing or to grant such purchaser a credit for the Product or parts as depreciated and accept its return. The depreciation will be an equal amount per year over the lifetime of the Product or parts as established by MOTOROLA.

MOTOROLA will have no liability with respect to any claim of patent infringement which is based upon the combination of the Product or parts furnished hereunder with software, apparatus or devices not furnished by MOTOROLA, nor will MOTOROLA have any liability for the use of ancillary equipment or software not furnished by MOTOROLA which is attached to or used in connection with the Product. The foregoing states the entire liability of MOTOROLA with respect to infringement of patents by the Product or any parts thereof.

Laws in the United States and other countries preserve for MOTOROLA certain exclusive rights for copyrighted MOTOROLA software such as the exclusive rights to reproduce in copies and distribute copies of such Motorola software. MOTOROLA software may be used in only the Product in which the software was originally embodied and such software in such Product may not be replaced, copied, distributed, modified in any way, or used to produce any derivative thereof. No other use including, without limitation, alteration, modification, reproduction, distribution, or reverse engineering of such MOTOROLA software or exercise of rights in such MOTOROLA software is permitted. No license is granted by implication, estoppel or otherwise under MOTOROLA patent rights or copyrights.

VII. Governing Law

This Warranty is governed by the laws of the State of Illinois, USA.

Notes

Chapter 1 Introduction

1.1 Notations Used in This Manual

Throughout the text in this publication, you will notice the use of note and caution notations. These notations are used to emphasize that safety hazards exist, and due care must be taken and observed.

NOTE: An operational procedure, practice, or condition that is essential to emphasize.

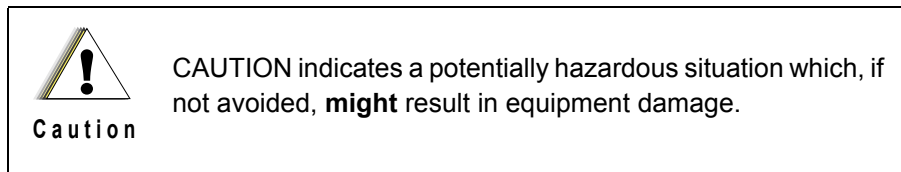

1.2 Radio Description

The XPR 5000 series mobile radios are available in the following frequency ranges and power levels.

Table 1-1 Radio Frequency Ranges and Power Levels

Freq. Band	Bandwidth	Power Level
VHF	136–174 MHz	1–25 Watts 25–45 Watts
UHF B1	403–470 MHz	1–25 Watts 25–40 Watts
UHF B2*	450–512 MHz	1–25 Watts 25–40 Watts

* For future release.

These radios are among the most sophisticated two-way radios available. They have a robust design for radio users who need high performance, quality, and reliability in their daily communications. This architecture provides the capability of supporting a multitude of legacy and advanced features resulting in a more cost-effective two-way radio communications solution.

1.3 Control Head Description

The control head used with the radio has logic circuitry that operates the standard and optional features built into the system.

The following illustrations show the typical radio control heads.

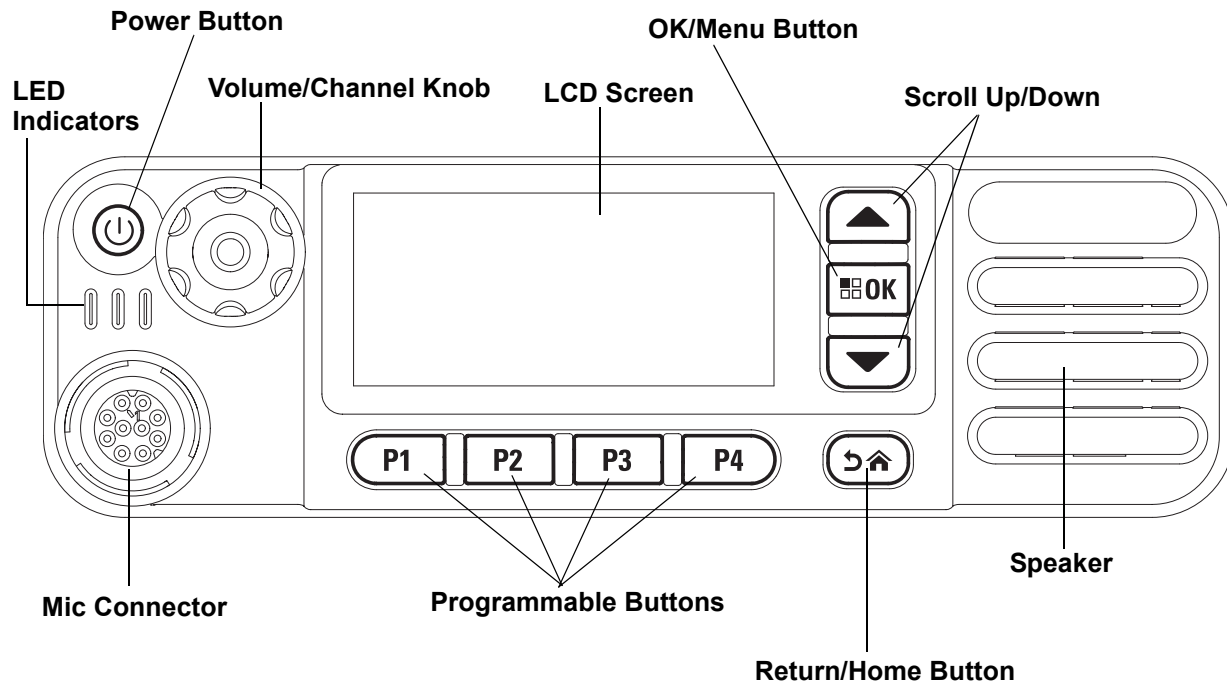

Figure 1-1 Radio Control Head (Color Display Model)

1.3.1 Control Head Controls (Color Display Model)

- **POWER BUTTON** – Turns the radio on and off.
- **VOLUME/CHANNEL KNOB** – Rotate clockwise to increase volume level; rotate counterclockwise to decrease volume level. Push knob to activate channel function; rotate clockwise and counterclockwise to select channel.
- **LED INDICATORS** – Red, yellow and green light-emitting diodes indicate operating status.
- **LCD (Liquid Crystal Display)** – 160x72 display provides visual information about many radio features.
- **OK/MENU BUTTON** – One button to provide menu navigation and selection interface.
- **PROGRAMMABLE BUTTONS** – Four buttons are field programmable using the CPS.
- **SCROLL UP/DOWN BUTTONS** – Press buttons to scroll.
- **RETURN/HOME BUTTON** – One button which quickly brings you to the home page.

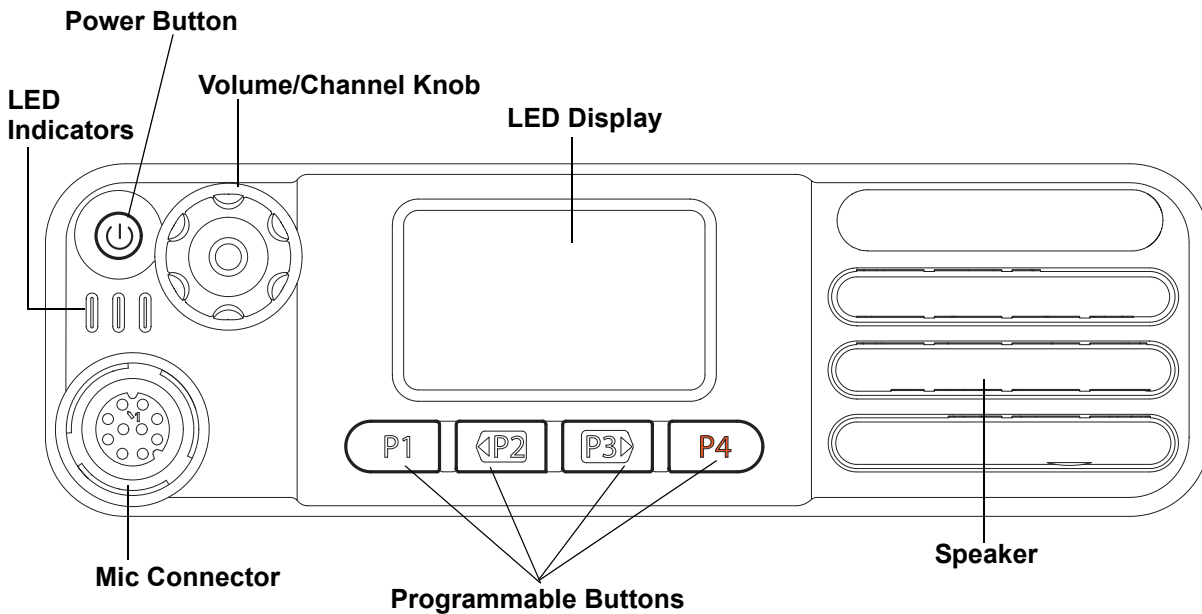

Figure 1-2 Radio Control Head (Numeric Display Model)

1.3.2 Control Head Controls (Numeric Display Model)

- POWER BUTTON – Turns the radio on and off.
- VOLUME/CHANNEL KNOB – Rotate clockwise to increase volume level; rotate counterclockwise to decrease volume level. Push knob to activate channel function; rotate clockwise and counterclockwise to select channel.
- LED INDICATORS – Red, yellow and green light-emitting diodes indicate operating status.
- LED NUMERIC DISPLAY – Two digit numeric display.
- PROGRAMMABLE BUTTONS – Four buttons are field programmable using the CPS.

1.4 MOTOTRBO Mobile Radio Model Numbering Scheme

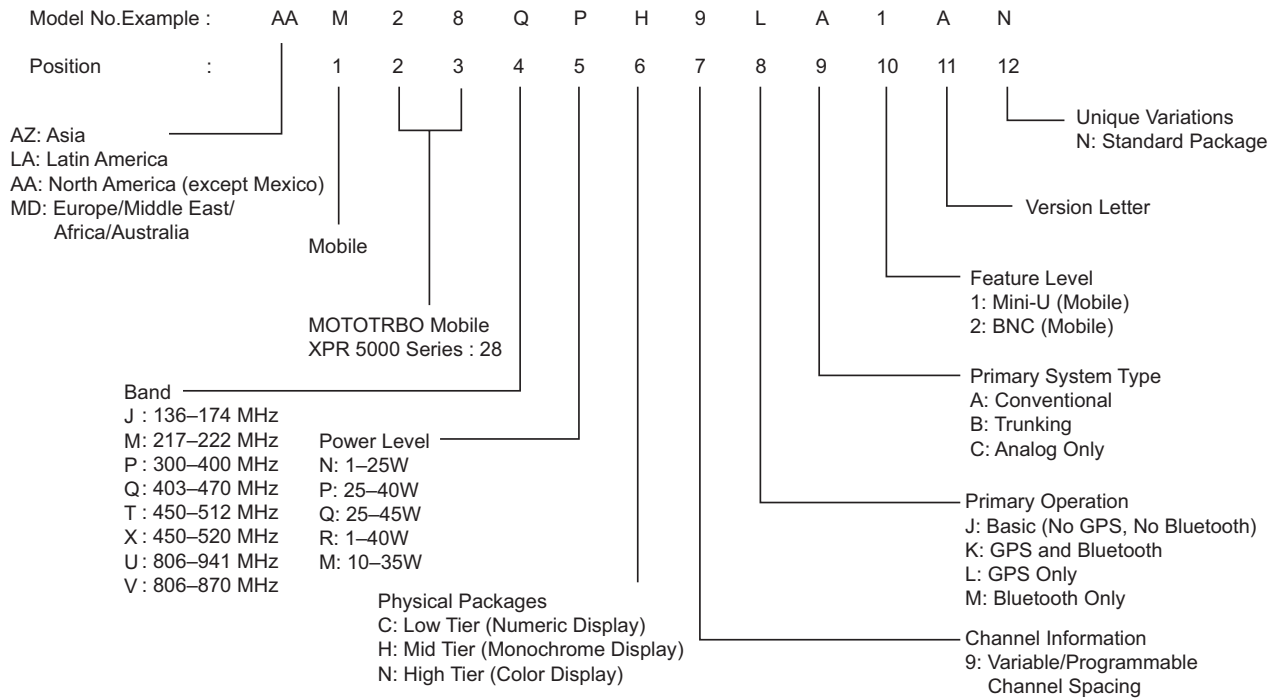

Figure 1-3 Mobile Radio Model Numbering Scheme

1.5 VHF High Power (136–174 MHz) Model Chart

VHF 136–174 MHz 25–45W, Mini-U			
Model		Description	
AAM28JQC9KA1_N		136–174 MHz, 25–45W, MOTOTRBO XPR 5350 Numeric Display Mobile with Bluetooth and GPS	
AAM28JQN9KA1_N		136–174 MHz, 25–45W, MOTOTRBO XPR 5550 Color Display Mobile with Bluetooth and GPS	
Item		Description	
X	X	PMUD2567_S	*Service Kit, VHF, 25–45W
X	X	PMLN6042_S	Service Kit, Bluetooth and GPS Expansion Board
X	X	PMLN5718_S	Service Kit, Generic Option Board
X		PMLN5677_	Numeric Display Model Control Head
	X	PMLN5678_	Color Display Model Control Head
X	X	68009508001	Mobile Quick Reference Guide and Safety Booklet

X = Item Included

* = Service Kit is the main board only

_ = the latest version kit. When ordering a kit, refer to your specific kit for the suffix number.

1.6 VHF Low Power (136–174 MHz) Model Chart

VHF 136–174 MHz 1–25W, Mini-U			
Model		Description	
AAM28JNC9KA1_N		136–174 MHz, 1–25W, MOTOTRBO XPR 5350 Numeric Display Mobile with Bluetooth and GPS	
AAM28JNN9KA1_N		136–174 MHz, 1–25W, MOTOTRBO XPR 5550 Color Display Mobile with Bluetooth and GPS	
Item		Description	
X	X	PMUD2566_S	*Service Kit , VHF, 1–25W
X	X	PMLN6042_S	Service Kit, Bluetooth and GPS Expansion Board
X	X	PMLN5718_S	Service Kit, Generic Option Board
X		PMLN5677_	Numeric Display Model Control Head
	X	PMLN5678_	Color Display Model Control Head
X	X	68009508001	Mobile Quick Reference Guide and Safety Booklet

X = Item Included

* = Service Kit is the main board only

_ = the latest version kit. When ordering a kit, refer to your specific kit for the suffix number.

1.7 UHF1 High Power (403–470 MHz) Model Chart

UHF1 403–470 MHz 25–40W, Mini-U			
Model		Description	
AAM28QPC9KA1_N		403–470 MHz, 25–40W, MOTOTRBO XPR 5350 Numeric Display Mobile with Bluetooth and GPS	
AAM28QPN9KA1_N		403–470 MHz, 25–40W, MOTOTRBO XPR 5550 Color Display Mobile with Bluetooth and GPS	
		Item	Description
X	X	PMUE3649_S	*Service Kit, UHF1, 25–40W
X	X	PMLN6042_S	Service Kit, Bluetooth and GPS Expansion Board
X	X	PMLN5718_S	Service Kit, Generic Option Board
X		PMLN5677_	Numeric Display Model Control Head
	X	PMLN5678_	Color Display Model Control Head
X	X	68009508001	Mobile Quick Reference Guide and Safety Booklet

X = Item Included

* = Service Kit is the main board only

_ = the latest version kit. When ordering a kit, refer to your specific kit for the suffix number.

1.8 UHF1 Low Power (403–470 MHz) Model Chart

UHF1 403–470 MHz 1–25W, Mini-U			
Model		Description	
AAM28QNC9KA1_N		403–470 MHz, 1–25W, MOTOTRBO XPR 5350 Numeric Display Mobile with Bluetooth and GPS	
AAM28QNN9KA1_N		403–470 MHz, 1–25W, MOTOTRBO XPR 5550 Color Display Mobile with Bluetooth and GPS	
		Item	Description
X	X	PMUE3645_S	*Service Kit, UHF1, 1–25W
X	X	PMLN6042_S	Service Kit, Bluetooth and GPS Expansion Board
X	X	PMLN5718_S	Service Kit, Generic Option Board
X		PMLN5677_	Numeric Display Model Control Head
	X	PMLN5678_	Color Display Model Control Head
X	X	68009508001	Mobile Quick Reference Guide and Safety Booklet

X = Item Included

* = Service Kit is the main board only

_ = the latest version kit. When ordering a kit, refer to your specific kit for the suffix number.

1.9 Specifications

General				
Specification	VHF		UHF1	
Model:	Numeric Display	Color Display	Numeric Display	Color Display
Channel Capacity:	32	1000	32	1000
Typical RF Output: Low Power High Power	1–25 W 25–45 W		1–25 W 25–40 W	
Frequency Range:	136–174 MHz		403–470 MHz	
Dimensions: (HxWxL)	2.1 x 6.9 x 8.1 in (53.3 x 175.3 x 205.7 mm)			
Weight:	3.9 lbs. (1.8 kg)			
Current Drain: Standby Rx @ rated audio Transmit	0.81 A max 2 A max 1–25 W: 11.0 A max 25–40 W: 14.5 A max 25–45 W: 14.5 A max			
FCC Description:	1–25 W: ABZ99FT3086 25–45 W: ABZ99FT3087		1–25 W: ABZ99FT4087 25–40 W: ABZ99FT4088	
IC Description:	1–25 W: 109AB-99FT3086 25–45 W: 109AB-99FT3087		1–25 W: 109AB-99FT4087 25–40 W: 109AB-99FT4088	

Receiver				
Specification	VHF		UHF1	
Model:	Numeric Display	Color Display	Numeric Display	Color Display
Frequencies:	136–174 MHz		403–470 MHz	
Channel Spacing:	12.5 kHz/20 kHz/25 kHz*			
Analog Sensitivity (12 dB Sinad):	0.3 μ V 0.22 μ V (Typical)			
Digital Sensitivity:	5% BER: 0.3 μ V			
Intermodulation TIA603D:	78 dB		75 dB	
Adjacent Channel Selectivity TIA603D:	50 dB @ 12.5 kHz, 80 dB @ 25 kHz		50 dB @ 12.5 kHz, 75 dB @ 25 kHz	
Spurious Rejection TIA603D:	80 dB		75 dB	
Rated Audio:	3 W (Internal) 7.5 W (External – 8 ohms) 13 W (External – 4 ohms)			
Audio Distortion @ Rated Audio:	3% (Typical)			
Hum and Noise:	-40 dB @ 12.5 kHz -45 dB @ 20/25 kHz			
Audio Response:	TIA603D			
Conducted Spurious Emission (TIA603D):	-57 dBm			

*Note: 20 kHz/25 kHz for Industry Canada only.

Transmitter				
Specification	VHF		UHF1	
Model:	Numeric Display	Color Display	Numeric Display	Color Display
Frequencies:	136–174 MHz		403–470 MHz	
Channel Spacing:	12.5 kHz/20 kHz/25 kHz*			
Frequency Stability: (-30°C to +60°C, +25°C Ref)	±0.5 ppm			
Power Output: Low Power High Power	1–25 W 25–45 W		1–25 W 25–40 W	
Modulation Limiting:	±2.5 kHz @ 12.5 kHz ±4.0 kHz @ 20 kHz ±5.0 kHz @ 25 kHz			
FM Hum and Noise:	-40 dB @ 12.5 kHz -45 dB @ 20/25 kHz			
Conducted/ Radiated Emission:	-36 dBm <1 GHz -30 dBm >1 GHz			
Adjacent Channel Power (TIA603D):	60 dB @ 12.5 kHz 70 dB @ 20/25 kHz			
Audio Response:	TIA603D			
Audio Distortion:	3%			
FM Modulation	12.5 kHz: 11K0F3E 25 kHz: 16K0F3E			
4FSK Digital Modulation	12.5 kHz Data: 7K60F1D & 7K60FXD 12.5 kHz Voice: 7K60F1E & 7K60FXE Combination of 12.5 kHz Voice & Data: 7K60F1W			
Digital Vocoder Type:	AMBE+2™			
Digital Protocol:	ETSI TS 102 361-1 ETSI TS 102 361-2 ETSI TS 102 361-3			

*Note: 20 kHz/25 kHz for Industry Canada only.

Self-Quieter	
VHF	UHF1
-	-

GPS				
Specification	VHF		UHF1	
Model:	Numeric Display	Color Display	Numeric Display	Color Display
Accuracy specs are for long-term tracking (95th percentile values > 5 satellites visible at a nominal -130 dBm signal strength).				
TTF (Time to First Fix) Cold Start:	< 1 minute			
TTF Hot Start:	< 10 seconds			
Horizontal Accuracy:	< 5 meters			

Bluetooth® 				
Specification	VHF		UHF1	
Model:	Numeric Display	Color Display	Numeric Display	Color Display
Version:	Supports Bluetooth 2.1 + EDR Specification.			
Range:	Class 2, 10 meters			

Military Standards 810C, D, E, F & G										
	MIL-STD 810C		MIL-STD 810D		MIL-STD 810E		MIL-STD 810F		MIL-STD 810G	
	Method	Proc./Cat	Method	Proc./Cat	Method	Proc./Cat	Method	Proc./Cat	Method	Proc./Cat
Low Pressure	500.1	I	500.2	II	500.3	II	500.4	II	500.5	II
High Temperature	501.1	I, II	501.2	I/A1, II/A1	501.3	I/A, II/A1	501.4	I/HOT, II/HOT	501.5	I/A1, II
Low Temperature	502.1	I	502.2	I/C3, II/C1	502.3	I/C3, II/C1	502.4	I/C3, II/C1	502.5	I/C3, II
Temperature Shock	503.1	–	503.2	I/A1/C3	503.3	I/A1/C3	503.4	I	503.5	I/C
Solar Radiation	505.1	II	505.2	I	505.3	I	505.4	I	505.5	I/A1
Rain	506.1	I, II	506.2	I, II	506.3	I, II	506.4	I, III	506.5	I, III
Humidity	507.1	II	507.2	II	507.3	II	507.4	–	507.5	II - Aggravated
Salt Fog	509.1	–	509.2	–	509.3	–	509.4	–	509.5	–
Dust	510.1	I	510.2	I	510.3	I	510.4	I	510.5	I
Vibration	514.2	VIII/F, Curve-W	514.3	I/10, II/3	514.4	I/10, II/3	514.5	I/24	514.6	I/24
Shock	516.2	I, II	516.3	I, IV	516.4	I, IV	516.5	I, IV	516.6	I, IV, V, VI

Environmental Specifications	
Operating Temperature	-30°C to +60°C
Storage Temperature	-40°C to +85°C
Temperature Shock	Per MIL-STD
Humidity	Per MIL-STD
ESD	IEC 61000-4-2 Level 3
Water and Dust Intrusion	IP54, MIL-STD

Notes

Chapter 2 Test Equipment and Service Aids

2.1 Recommended Test Equipment

The list of equipment contained in Table 2-1 includes most of the standard test equipment required for servicing Motorola mobile radios.

Table 2-1 Recommended Test Equipment

Equipment	Characteristic	Example	Application
Service Monitor	Can be used as a substitute for items marked with an asterisk (*)	Aeroflex 2945B, Aeroflex 3920, or equivalent	Frequency/deviation meter and signal generator for wide-range troubleshooting and alignment
Digital RMS Multimeter*	100 μ V to 300 V 5 Hz to 1 MHz 10 Meg Ohm Impedance	Fluke 179 or equivalent (www.fluke.com)	AC/DC voltage and current measurements. Audio voltage measurements.
RF Signal Generator*	100 MHz to 1 GHz -130 dBm to +10 dBm FM Modulation 0 kHz to 10 kHz	Agilent N5181 (www.agilent.com) or equivalent	Receiver measurements
Oscilloscope*	2 Channels 50 MHz Bandwidth 5 mV/div to 20 V/div	Tektronix TDS1001b (www.tektronix.com) or equivalent	Waveform measurements
Power Meter and Sensor*	5% Accuracy 100 MHz to 500 MHz 50 Watts	Bird 43 Thruline Watt Meter (www.bird-electronic.com) or equivalent	Transmitter power output measurements
RF Millivolt Meter	100 mV to 3 V RF 10 kHz to 1 GHz	Boonton 92EA (www.boonton.com) or equivalent	RF level measurements
Power Supply	0 V to 32 V 0 A to 20 A	B&K Precision 1790 (www.bkprecision.com) or equivalent	Voltage supply

2.2 Service Aids

Table 2-2 lists the service aids recommended for working on the radio. While all of these items are available from Motorola, most are standard workshop equipment items, and any equivalent item capable of the same performance may be substituted for the item listed.

Table 2-2 Service Aids

Motorola Part Number	Description	Application
RLN4460_	Test Set	Enables connection to audio/accessory jack. Allows switching for radio testing.
RVN5115_	Customer Programming Software on CD-ROM	Allows servicer to program radio parameters, tune and troubleshoot radios.
PMKN4010_	Mobile & Repeater Rear Programming Cable	Connects the radio's rear connector to a USB port for radio programming and data applications.
PMKN4016_	Mobile & Repeater Rear Accessory Programming and Test Cable	Connects the radio's rear connector to a USB port for radio programming, data applications, testing and alignment.
PMKN4018_	Mobile & Repeater Rear Accessory Connector Universal Cable	Connects the radio's rear connector to accessory devices such as desk sets. Cable contains all 26 wires and is unterminated at the user end.
HKN6184_	Mobile Front Programming Cable	Connects the radio's front connector to a USB port for radio programming and data applications.
HPN4007_	Power Supply	Provides the radio with power when bench testing.
PMEN4027_	Housing Eliminator	Test Fixture used to bench test the radio PCB.
6686119B01	Control Head Dismantling Tool	Assists in the removal of radio control head.
66012025001	Volume/Channel Knob Removal Tool	Assists in the removal of the Volume/Channel knob.
66012020001	RFIC (U0000) Repair Stencil	Fixture to screen solder paste onto the IC leads for replacement.

2.3 Programming Cables



Figure 2-1 Mobile Front Programming Cable HKN6184_

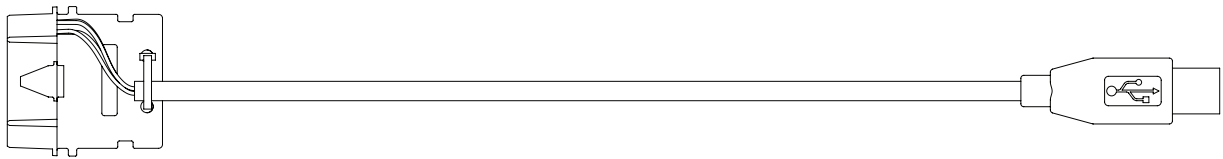

Figure 2-2 Mobile & Repeater Rear Programming Cable PMKN4010_

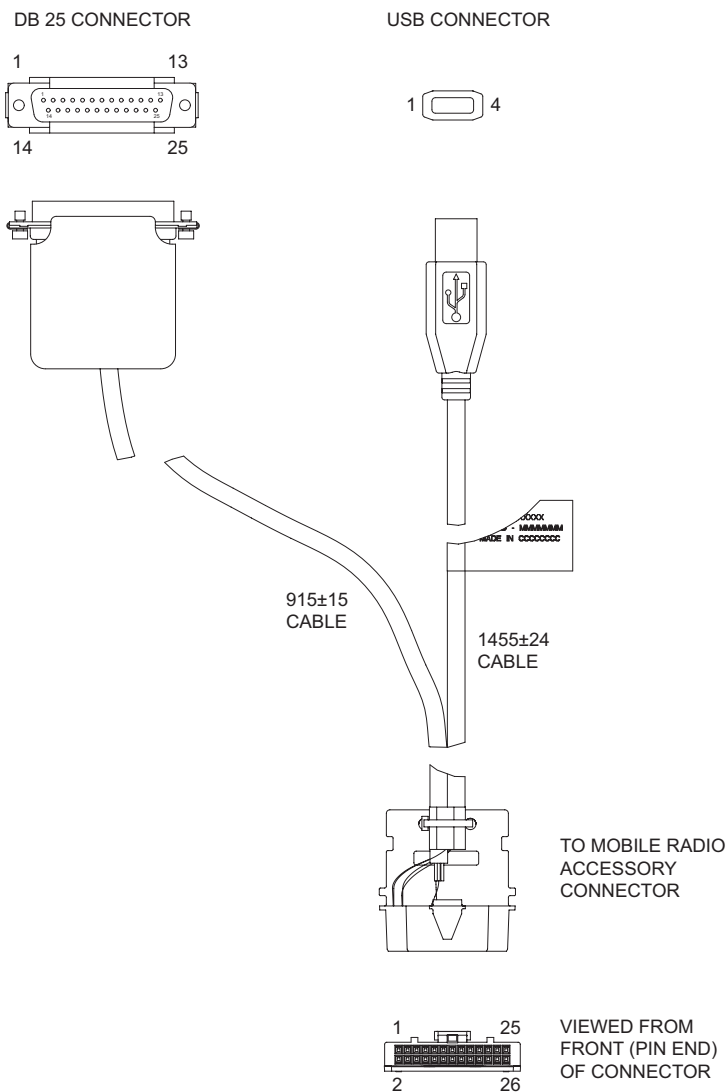

TABLE 2-3: WIRE DIAGRAM

26 PIN ACCESSORY PORT CONNECTOR		USB	DB25P
PIN NO.	DESCRIPTION		
3	VCC (5v)	1	
2	DATA -	2	
1	DATA +	3	
4	GND	4	
	DRAIN WIRE AND BRAID	SHELL	
9	SPEAKER -		7
11	EXT MIC		17
17	DIGI IN I (EXT PTT)		20
16	GND		16
10	SPEAKER +		1

Figure 2-3 Mobile & Repeater Rear Accessory Programming and Test Cable PMKN4016_

Notes

Chapter 3 Transceiver Performance Testing

3.1 General

These radios meet published specifications through their manufacturing process by utilizing high-accuracy laboratory-quality test equipment. The recommended field service equipment approaches the accuracy of the manufacturing equipment with few exceptions. This accuracy must be maintained in compliance with the manufacturer’s recommended calibration schedule.

NOTE: Although these radios function in digital and analog modes, all testing is done in analog mode.

3.2 Setup

Supply voltage is provided using a 13.8 VDC power supply. (Note: applying 13.8 VDC at the DC power cable will ensure a minimum of 13.2 VDC at the DC connector of the radio). The equipment required for alignment procedures is shown in the Radio Tuning Equipment Setup Diagram, Figure 4-4.

Initial equipment control settings should be as indicated in Table 3-1. The remaining tables in this chapter contain the following related technical data:

Table Number	Title
3-2	Front Panel Access Test Mode Displays
3-3	Test Environments
3-4	Test Channel Spacing
3-5	Test Frequencies
3-6	Transmitter Performance Checks
3-7	Receiver Performance Checks

Table 3-1 Initial Equipment Control Settings

Service Monitor	Power Supply	Test Set
Monitor Mode: Power Monitor	Voltage: 13.8 VDC	Speaker set: A
RF Attenuation: -70	DC On/Standby: Standby	Speaker/load: Speaker
AM, CW, FM: FM	Volt Range: 20 V	PTT: OFF
Oscilloscope Source: Mod Oscilloscope Horizontal: 10 mSec/Div Oscilloscope Vertical: 2.5 kHz/Div Oscilloscope Trigger: Auto Monitor Image: Hi Monitor Bandwidth: Narrow Monitor Squelch: middle setting Monitor Vol: 1/4 setting	Current: 20 A	

3.3 Color Display Model Test Mode

3.3.1 Entering Display Radio Test Mode

1. Turn the radio on.
2. Within ten seconds after self test is complete, press **button P2**, five times in succession.
3. The radio beeps and will show a series of displays that will give information regarding various version numbers and subscriber specific information. The displays are described in Table 3-2.

Table 3-2 Front Panel Access Test Mode Displays

Name of Display	Description	Appears
Service Mode	The literal string indicates the radio has entered test mode.	Always
Host Version	The version of host firmware.	Always
DSP Version	The version of DSP firmware.	Always
Model Number	The radio's model number as programmed in the codeplug.	Always
MSN	The radio's serial number as programmed in the codeplug.	Always
FLASHCODE	The FLASH codes as programmed in the codeplug.	Always
RF Band	The radio's band.	Always

NOTE: The radio stops at each display for 2 seconds before moving to the next information display. If the information cannot fit into 1 line, the radio display scrolls automatically character by character after 1 second to view the whole information. If the Top Navigation Button (▲) is pressed before the last information display, the radio shall suspend the information display until the user presses Bottom Navigation Button (▼) to resume the information display. The radio beeps for each button press. After the last display, RF Test Mode will be displayed.

3.3.2 RF Test Mode

When the radio is operating in its normal environment, the radio's microcontroller controls the RF channel selection, transmitter key-up, and receiver muting, according to the customer codeplug configuration. However, when the unit is on the bench for testing, alignment, or repair, it must be removed from its normal environment via a special routine, called **TEST MODE** or air test.

In RF Test Mode, the display upon the first line is "RF Test", together with the power level icon at the right end of the first line. The display upon the second line is the test environment, the channel number and channel spacing ("CSQ CHXX SP25"). The default test environment is CSQ.

1. Each short press of **button P2** changes the test environment (CSQ->TPL->DIG->USQ->CSQ). The radio beeps once when radio toggles to CSQ, beeps twice for TPL, beeps three times for DIG and beeps four times for USQ.

NOTE: DIG is digital mode and other test environments are analog mode as described in Table 3-3.

2. Each short press of **button P1** toggles the channel spacing between 20 kHz, 25 kHz and 12.5 kHz. The radio beeps once when radio toggles to 20 kHz, beeps twice for 25 kHz and beeps three times for 12.5 kHz.

3. Push and hold in the Volume/Channel knob for approximately two seconds to enter the Channel mode. Turn the Volume/Channel knob clockwise to increase from channel 1 to channel 14 or counterclockwise to decrease the channel number. The radio beeps in each position. The channel test frequencies are described in Table 3-5.

NOTE: The Volume/Channel knob will stay in Channel mode until the Volume/Channel knob is pushed in momentarily. This is not the case in normal operation.

3.3.3 Color Display Test Mode

1. Press and hold **button P1** in RF Test Mode. The radio beeps once and momentarily displays '**Display Test Mode**'.
2. On the next button press, the negative image of **Display Test Mode** will appear.
3. With each successive button press, the display background will change from Red, to Green, and then to Blue.
4. With each successive button press, a horizontal bar will increase in size and change color, from Red, to Green, to Blue, to Black, back to Red, to Green, to Blue, to Black, and finally, the entire display background will change to Red.
5. With each successive button press, vertical bars will grow and change color, from Red, to Green, to Blue, to Black, back to Red, and finally, the entire display background will change to Green.
6. On the next button press, the display will clear and 12 icons will appear at the top of the display.

3.3.4 LED Test Mode

1. Press and hold **button P1** after Display Test Mode. The radio beeps once and displays "LED Test Mode".
2. Upon any button press, the radio lights on the red LED and displays "Red LED On".
3. Consequently, upon any button press, the red LED is turned off and the radio lights on the green LED and displays "Green LED On".
4. Consequently, upon any button press, the green LED is turned off and the radio shall light on the yellow LED and displays "Yellow LED On".

3.3.5 Backlight Test Mode

1. Press and hold **button P1** after LED Test Mode. The radio beeps once and displays "Backlight Test Mode".
2. The radio lights on both LCD and keypad backlight together.

3.3.6 Speaker Tone Test Mode

1. Press and hold **button P1** after Backlight Test Mode. The radio beeps once and displays "Speaker Tone Test Mode".
2. The radio generates a 1 kHz tone with the internal speaker.

3.3.7 Earpiece Tone Test Mode

1. Press and hold **button P1** after Speaker Tone Test Mode. The radio beeps once and displays "Earpiece Tone Test Mode".
2. The radio generates a 1 kHz tone with the earpiece.

3.3.8 Audio Loopback Test Mode

1. Press and hold **button P1** after Earpiece Tone Test Mode. The radio beeps once and displays “Audio Loopback Test Mode”.
2. The radio shall route any audio on the mic to the internal speaker.

3.3.9 Audio Loopback Earpiece Test Mode

1. Press and hold **button P1** after Audio Loopback Test Mode. The radio beeps once and displays “Audio Loopback Earpiece Test Mode”.
2. The radio shall route any audio on the mic to the accessory earpiece.

3.3.10 Button/Knob/PTT Test Mode

1. Press and hold **button P1** after Audio Loopback Earpiece Test Mode. The radio beeps once and displays “Button Test” (line 1).
2. The radio also displays the button/knob/PTT Button Command Opcode (BCO) and state (BCO/state) on the screen (line 2) upon any button state changes.
3. The radio must be powered off to end Test Mode.

3.4 Numeric Display Model Test Mode

3.4.1 Entering Display Radio Test Mode

1. Turn the radio on.
2. Within ten seconds after self test is complete, press **button P2**, five times in succession.
3. The radio beeps.

3.4.2 RF Test Mode

When the radio is operating in its normal environment, the radio's microcontroller controls the RF channel selection, transmitter key-up, and receiver muting, according to the customer codeplug configuration. However, when the unit is on the bench for testing, alignment, or repair, it must be removed from its normal environment via a special routine, called **TEST MODE** or air test.

1. Each short press of **button P2** changes the test environment (CSQ->TPL->DIG->USQ->CSQ). The radio beeps once when radio toggles to CSQ, beeps twice for TPL, beeps three times for DIG and beeps four times for USQ.

NOTE: DIG is digital mode and other test environments are analog mode as described in Table 3-3.

2. Each short press of **button P1** toggles the channel spacing between 20 kHz, 25 kHz and 12.5 kHz. The radio beeps once when radio toggles to 20 kHz, beeps twice for 25 kHz and beeps three times for 12.5 kHz.
3. Push and hold in the Volume/Channel knob for approximately two seconds to enter the Channel mode. Turn the Volume/Channel knob clockwise to increase from channel 1 to channel 14 or counterclockwise to decrease the channel number. The radio beeps in each position. The channel test frequencies are described in Table 3-5.

NOTE: The Volume/Channel knob will stay in Channel mode until the Volume/Channel knob is pushed in momentarily. This is not the case in normal operation.

3.4.3 Display Test Mode

1. Press and hold **button P1** in RF Test Mode. The radio beeps once and enters 'Display Test Mode'.
2. Upon entering Display Test Mode, press any button to turn on the two character seven segment display.

3.4.4 LED Test Mode

1. Press and hold **button P1** after Display Test Mode. The radio beeps once.
2. Upon any button press, the radio lights on the red LED.
3. Consequently, upon any button press, the red LED is turned off and the radio lights on the green LED.
4. Consequently, upon any button press, the green LED is turned off and the radio shall light on the yellow LED.

3.4.5 Speaker Tone Test Mode

1. Press and hold **button P1** after LED Test Mode. The radio beeps once.
2. The radio generates a 1 kHz tone with the internal speaker.

3.4.6 Earpiece Tone Test Mode

1. Press and hold **button P1** after Speaker Tone Test Mode. The radio beeps once.
2. The radio generates a 1 kHz tone with the earpiece.

3.4.7 Audio Loopback Test Mode

1. Press and hold **button P1** after Earpiece Tone Test Mode. The radio beeps once.
2. The radio shall route any audio on the mic to the internal speaker.

3.4.8 Audio Loopback Earpiece Test Mode

1. Press and hold **button P1** after Audio Loopback Test Mode. The radio beeps once.
2. The radio shall route any audio on the mic to the accessory earpiece.

3.4.9 Button/Knob/PTT Test Mode

1. Press and hold **button P1** after Audio Loopback Earpiece Test Mode. The radio beeps once.
2. Rotate the volume knob, the radio beeps at each position.
3. Press any button, the radio beeps.
4. The radio must be powered off to end Test Mode.

Table 3-3 Test Environments

No. of Beeps	Description	Function
1	Carrier Squelch (CSQ)	RX: unsquelch if carrier detected TX: mic audio
2	Tone Private-Line (TPL)	RX: unsquelch if carrier and tone (192.8 Hz) detected TX: mic audio + tone (192.8 Hz)
3	Digital (DIG)	RX: unsquelch if carrier and digital code detected TX: mic audio
4	Unsquelch (USQ)	RX: constant unsquelch TX: mic audio

Table 3-4 Test Channel Spacing

Number of Beeps	Channel Spacing
1	20 kHz
2	25 kHz
3	12.5 kHz

Table 3-5 Test Frequencies

Test Mode	Test Channel Low Power	Test Channel High Power	VHF (MHz)	UHF1 (MHz)
TX	1	8	136.075	403.000
RX	1	8	136.075	403.000
TX	2	9	142.575	414.150
RX	2	9	142.575	414.150
TX	3	10	146.575	425.350
RX	3	10	146.575	425.350
TX	4	11	155.575	436.500
RX	4	11	155.575	436.500
TX	5	12	161.575	447.675
RX	5	12	161.575	447.675
TX	6	13	167.575	458.850
RX	6	13	167.575	458.850
TX	7	14	174.975	470.000
RX	7	14	174.975	470.000

Table 3-6 Transmitter Performance Checks

Test Name	Communications Analyzer	Radio	Test Set	Comment
Reference Frequency	Mode: PWR MON 4th channel test frequency* Monitor: Frequency error Input at RF In/Out	TEST MODE, Test Channel 4, carrier squelch	PTT to continuously transmit (during the performance check)	Frequency error: ±90 Hz (VHF) ±150 Hz (UHF)
Power RF	As above	TEST MODE Test Channel 4, carrier squelch TEST MODE Test Channel 11, carrier squelch	As above	Low Power: 1.0–1.3 W: (VHF 1–25 W, UHF1 1–25 W, UHF2 1–25 W) 25–29 W: (VHF 25–45 W, UHF1 25–40 W, UHF2 25–40 W) High Power: 25–29 W: (VHF 1–25 W, UHF1 1–25 W, UHF2 1–25 W) 40–47 W: (UHF1 25–40 W, UHF2 25–40 W) 45–53 W: (VHF 25–45 W)
Voice Modulation	Mode: PWR MON 4th channel test frequency* atten to -70, input to RF In/Out Monitor: DVM, AC Volts Set 1kHz Mod Out level for 800mVrms at test set, 800mVrms at AC/DC test set jack	TEST MODE Test Channel 4, carrier squelch	As above, meter selector to mic	Deviation: 2.5 kHz Max. (12.5 kHz Ch. Sp.). 4 kHz Max. (20 kHz Ch. Sp.). 5 kHz Max. (25 kHz Ch. Sp.).
Voice Modulation (internal)	Mode: PWR MON 4th channel test frequency* atten to -70, input to RF In/Out	TEST MODE, Test Channel 4 carrier squelch output at antenna	Remove modulation input	Deviation: 2.5 kHz Max. (12.5 kHz Ch. Sp.). 4 kHz Max. (20 kHz Ch. Sp.). 5 kHz Max. (25 kHz Ch. Sp.).
TPL Modulation	As above 4th channel test frequency* BW to narrow	TEST MODE, Test Channel 4 TPL	As above	Deviation: 0.25–0.5 kHz (12.5 kHz Ch. Sp.). 0.4–0.8 kHz (20 kHz Ch. Sp.). 0.5–1.0 kHz (25 kHz Ch. Sp.).

* See Table 3-5

Table 3-7 Receiver Performance Checks

Test Name	Communications Analyzer	Radio	Test Set	Comment
Rated Audio	Mode: GEN Output level: 1.0 mV RF 4th channel test frequency* Mod: 1 kHz tone at 3 kHz deviation Monitor: DVM: AC Volts	TEST MODE Test Channel 4, 25 kHz channel spacing, carrier squelch	PTT to OFF (center), meter selector to Audio PA	Set volume control to 7.75 Vrms
Distortion	As above, except to distortion	As above	As above	Distortion <5.0%
Sensitivity (SINAD)	As above, except SINAD, lower the RF level for 12 dB SINAD.	As above	PTT to OFF (center)	RF input to be <0.3 μ V
Noise Squelch Threshold (only radios with conventional system need to be tested)	RF level set to 1 mV RF	As above	PTT to OFF (center), meter selection to Audio PA, spkr/ load to speaker	Set volume control to 7.75 Vrms
	As above, except change frequency to a conventional system. Raise RF level from zero until radio unsquelches.	out of TEST MODE; select a conventional system	As above	Unsquelch to occur at <0.25 μ V. Preferred SINAD = 9–10 dB

* See Table 3-5

Chapter 4 Radio Programming and Tuning

4.1 Introduction

This chapter provides an overview of the MOTOTRBO Customer Programming Software (CPS), as well as the Tuner and AirTracer applications, which are all designed for use on a Windows 7/Vista/XP operating system. These programs are available in one kit as listed in Table 4-1. An Installation Guide is also included with the kit.

NOTE: Refer to the appropriate program on-line help files for the programming procedures.

Table 4-1 Radio Software Program Kit

Description	Kit Number
MOTOTRBO CPS, Tuner and AirTracer Applications CD	RVN5115_

4.2 Customer Programming Software Setup

The Customer Programming Software setups, shown in Figure 4-1 and Figure 4-2, are used to program the radio.

NOTE: Refer to the appropriate program on-line help files for the programming procedures.

CAUTION: Computer USB ports can be sensitive to Electronic Discharge.
Do not touch exposed contacts on cable when connected to a computer.

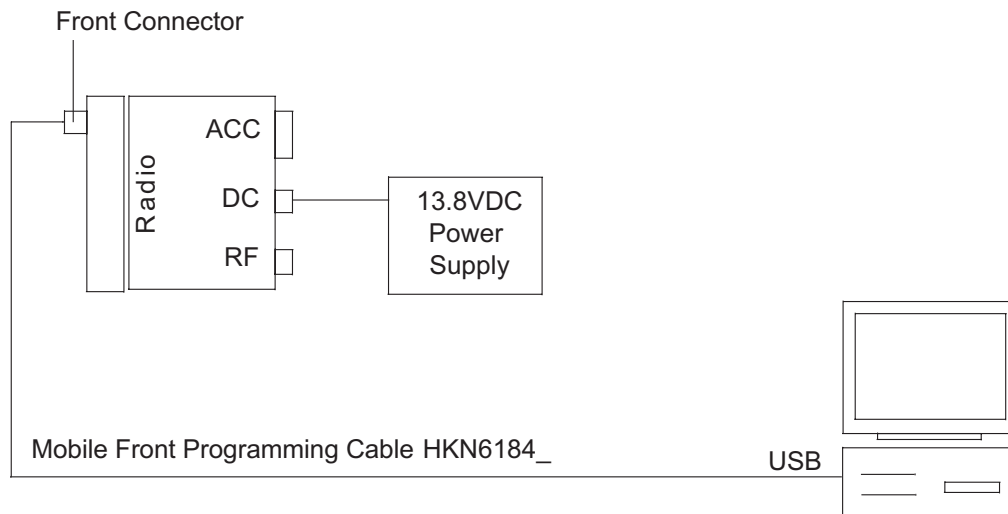

Figure 4-1 Customer Programming Software Setup from Front Connector

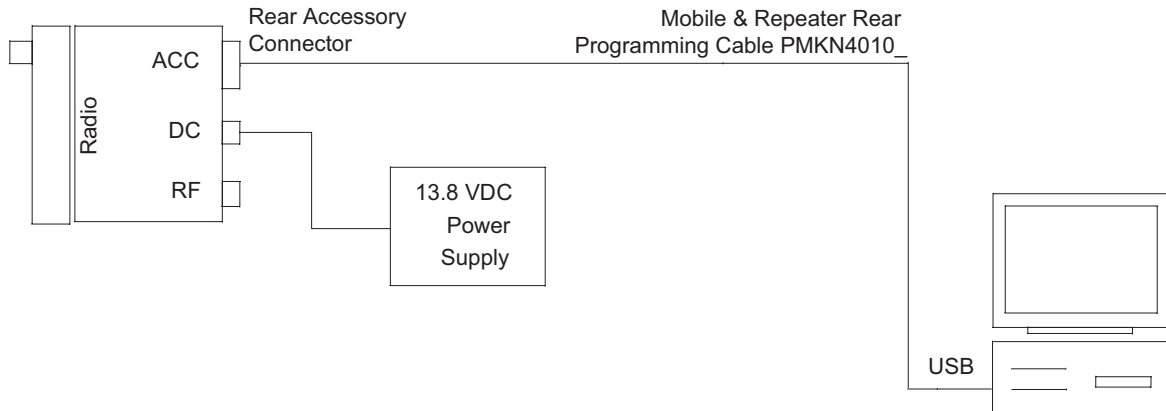

Figure 4-2 Customer Programming Software Setup from Rear Accessory Connector

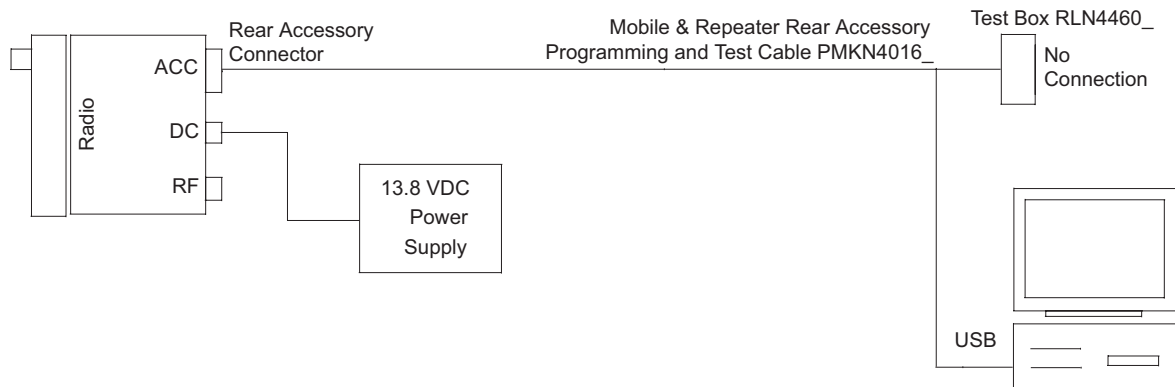

Figure 4-3 Customer Programming Software Setup with Test Box Connection

4.3 AirTracer Application Tool

The MOTOTRBO AirTracer application tool has the ability to capture over-the-air digital radio traffic and save the captured data into a file. The AirTracer application tool can also retrieve and save internal error logs from MOTOTRBO radios. The saved files can be analyzed by trained Motorola personnel to suggest improvements in system configurations or to help isolate problems.

4.4 Radio Tuning Setup

A personal computer (PC), Windows 7/Vista/XP and a tuner program (which is available as part of the MOTOTRBO CPS kit) are required to tune the radio. To perform the tuning procedures, the radio must be connected to the PC and test equipment setup as shown in Figure 4-4.

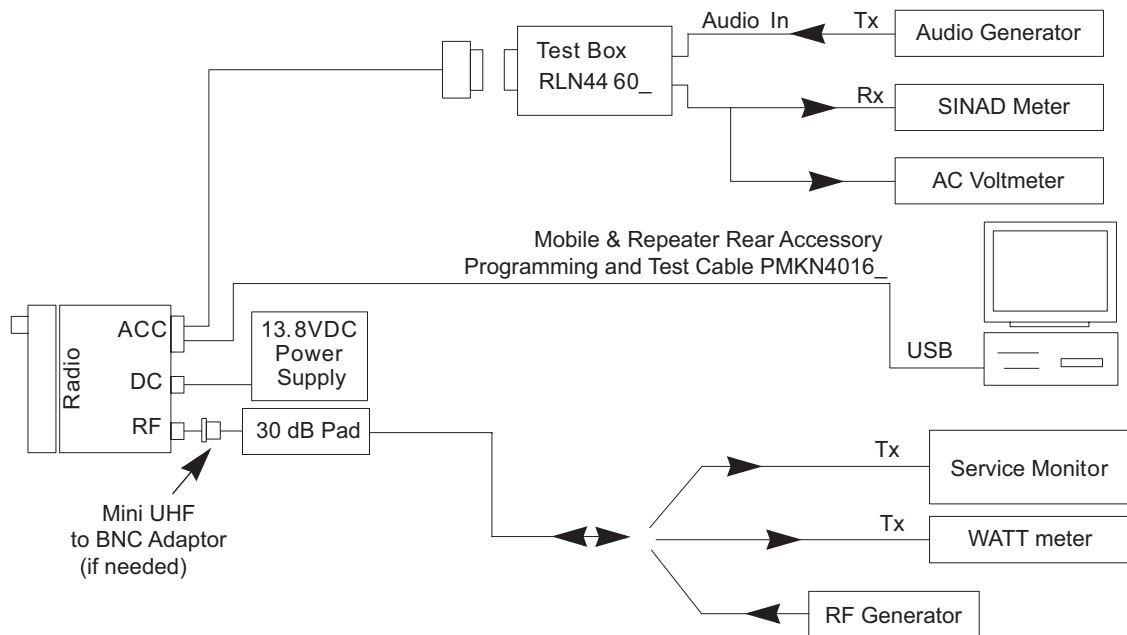

Figure 4-4 Radio Tuning Equipment Setup

Notes

Chapter 5 Disassembly/Reassembly Procedures

5.1 Introduction

This chapter provides details about the following:

- Preventive maintenance (inspection and cleaning).
- Safe handling of CMOS and LDMOS devices.
- Repair procedures and techniques.
- Disassembly and reassembly of the radio.

5.2 Preventive Maintenance

Periodic visual inspection and cleaning is recommended.

5.2.1 Inspection

Check that the external surfaces of the radio are clean, and that all external controls and switches are functional. It is not recommended to inspect the interior electronic circuitry.

5.2.2 Cleaning Procedures

The following procedures describe the recommended cleaning agents and the methods to be used when cleaning the external and internal surfaces of the radio. External surfaces include the control head and housing assembly. These surfaces should be cleaned whenever a periodic visual inspection reveals the presence of smudges, grease, and/or grime.

NOTE: Internal surfaces should be cleaned only when the radio is disassembled for service or repair.

The only recommended agent for cleaning the external radio surfaces is a 0.5% solution of a mild dishwashing detergent in water. The only factory recommended liquid for cleaning the printed circuit boards and their components is isopropyl alcohol (100% by volume).



Caution

Use all chemicals as prescribed by the manufacturer. Be sure to follow all safety precautions as defined on the label or material safety data sheet.

The effects of certain chemicals and their vapors can have harmful results on certain plastics. Avoid using aerosol sprays, tuner cleaners and other chemicals.

Cleaning External Plastic Surfaces

Apply the 0.5% detergent-water solution sparingly with a stiff, non-metallic, short-bristled brush to work all loose dirt away from the radio. Use a soft, absorbent, lintless cloth or tissue to remove the solution and dry the radio. Make sure that no water remains entrapped near the connectors, cracks, or crevices.

Cleaning Internal Circuit Boards and Components

Isopropyl alcohol (100%) may be applied with a stiff, non-metallic, short-bristled brush to dislodge embedded or caked materials located in hard-to-reach areas. The brush stroke should direct the dislodged material out and away from the inside of the radio. Make sure that controls or tunable components are not soaked with alcohol. Do not use high-pressure air to hasten the drying process since this could cause the liquid to collect in unwanted places. Once the cleaning process is complete, use a soft, absorbent, lintless cloth to dry the area. Do not brush or apply any isopropyl alcohol to the frame, control head and housing assembly.

NOTE: Always use a fresh supply of alcohol and a clean container to prevent contamination by dissolved material (from previous usage).

5.3 Safe Handling of CMOS and LDMOS Devices

Complementary Metal Oxide Semiconductor (CMOS) and Laterally Diffused Metal Oxide Semiconductor (LDMOS) devices are used in this family of radios, and are susceptible to damage by electrostatic or high voltage charges. Damage can be latent, resulting in failures occurring weeks or months later. Therefore, special precautions must be taken to prevent device damage during disassembly, troubleshooting, and repair.

Handling precautions are mandatory for CMOS/LDMOS circuits and are especially important in low humidity conditions.

DO NOT attempt to disassemble the radio without first referring to the following CAUTION statement.

**Caution**

This radio contains static-sensitive devices. Do not open the radio unless you are properly grounded. Take the following precautions when working on this unit:

- Store and transport all CMOS/LDMOS devices in conductive material so that all exposed leads are shorted together. Do not insert CMOS/LDMOS devices into conventional plastic “snow” trays used for storage and transportation of other semiconductor devices.
- Ground the working surface of the service bench to protect the CMOS/LDMOS device. We recommend using a wrist strap, two ground cords, a table mat, a floor mat, ESD shoes, and an ESD chair.
- Wear a conductive wrist strap in series with a 100k resistor to ground. (Replacement wrist straps that connect to the bench top covering are Motorola part number 4280385A59).
- Do not wear nylon clothing while handling CMOS/LDMOS devices.
- Do not insert or remove CMOS/LDMOS devices with power applied. Check all power supplies used for testing CMOS/LDMOS devices to be certain that there are no voltage transients present.
- When straightening CMOS/LDMOS pins, provide ground straps for the apparatus used.
- When soldering, use a grounded soldering iron.
- If at all possible, handle CMOS/LDMOS devices by the package and not by the leads. Prior to touching the unit, touch an electrical ground to remove any static charge that you may have accumulated. The package and substrate may be electrically common. If so, the reaction of a discharge to the case would cause the same damage as touching the leads.

5.4 Repair Procedures and Techniques – General

NOTE Environmentally Preferred Products (EPP) (refer to the marking on the printed circuit boards — examples shown below) were developed and assembled using environmentally preferred components and solder assembly techniques to comply with the European Union's **Restriction of Hazardous Substances (ROHS) Directive 2002/95/EC** and **Waste Electrical and Electronic Equipment (WEEE) Directive 2002/96/EC**. To maintain product compliance and reliability, use only the Motorola specified parts in this manual.

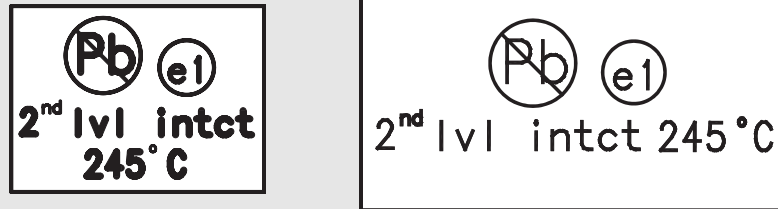

Any rework or repair on Environmentally Preferred Products must be done using the appropriate lead-free solder wire and lead-free solder paste as stated in the following table:

Table 5-1 Lead Free Solder Wire Part Number List

Motorola Part Number	Alloy	Flux Type	Flux Content by Weight	Melting Point	Supplier Part number	Diameter	Weight
1088929Y01	95.5Sn/3.8Ag/0.7Cu	RMA Version	2.7–3.2%	217°C	52171	0.015"	1lb spool

Table 5-2 Lead Free Solder Paste Part Number List

Motorola Part Number	Manufacturer Part Number	Viscosity	Type	Composition & Percent Metal	Liquid Temperature
1085674C03	NC-SMQ230	900–1000KCPs Brookfield (5rpm)	Type 3 (-325/+500)	(95.5%Sn-3.8%Ag-0.7%Cu) 89.3%	217°C

Parts Replacement and Substitution

Check the parts list for the proper Motorola part number and order the part from the nearest Motorola Radio Products and Solutions Organization listed in Appendix A of this manual.

Rigid Circuit Boards

This family of radios uses bonded, multi-layer, printed circuit boards. Since the inner layers are not accessible, some special considerations are required when soldering and unsoldering components. The printed-through holes may interconnect multiple layers of the printed circuit. Therefore, exercise care to avoid pulling the plated circuit out of the hole.

When soldering near a connector:

- Avoid accidentally getting solder in the connector.
- Be careful not to form solder bridges between the connector pins.
- Examine your work closely for shorts due to solder bridges.

5.5 Disassembling and Reassembling the Radio – General

Since these radios may be disassembled and reassembled with the use of only ten screws (board to casting), it is important to pay particular attention to the snaps and tabs, and how parts align with each other.

The following tools are required for disassembling and assembling the radio:

- Small Flat Blade Screwdriver
- Control Head Dismantling Tool (Motorola Part No. 6686119B01)
- Volume/Channel Knob Removal Tool (Motorola Part No. 66012025001)
- Torque Driver (2-36 lbs-in or 0.2-4.0 N-m), (Motorola Part No. RSX4043A)
- TORX™ T10 Driver Bit
- TORX™ T8 Driver Bit
- TORX™ T6 Driver Bit (for use with GPS Models and Option Board only)
- 5/16" or 8 mm Socket Driver (GPS Models Only)
- 9/16" Deep Socket Driver (RF Connector Nut)

If a unit requires more complete testing or service than is customarily performed at the basic level, please send radio to a Motorola Service Center listed in Appendix B.

The following disassembly procedures should be performed only if necessary.

5.6 Radio Disassembly – Detailed

The procedure to remove and replace the control head, top cover or transceiver board is similar for all models. A typical procedure is therefore provided in this section followed by detailed disassembly procedures for each specific control head model.

5.6.1 Control Head Removal

1. Insert the dismantling tool in the groove between the control head and the radio assembly as shown in Figure 5-1.
2. Press the dismantling tool under the control head to release the snap features.

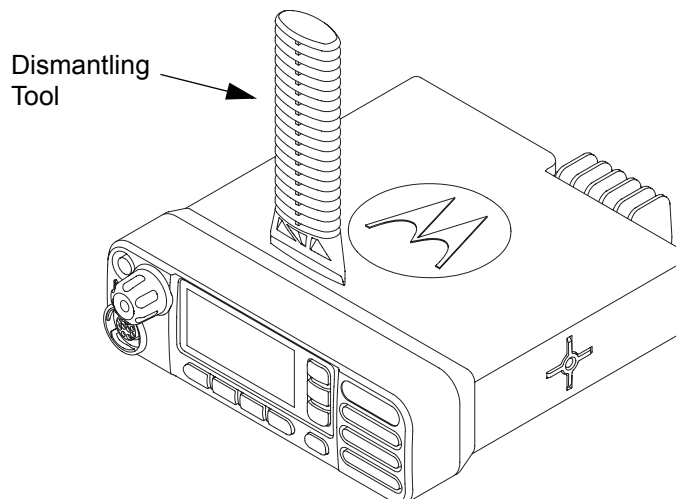

Figure 5-1 Typical Control Head Removal

3. Pull the control head away from the radio assembly as shown in Figure 5-2.

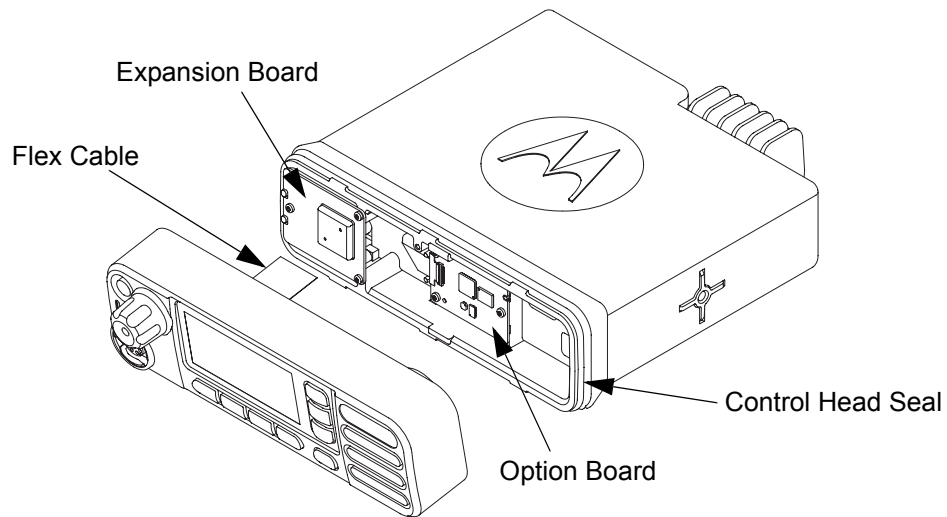

Figure 5-2 Flexible Connection Removal

4. Remove the flex cable from the socket on the radio assembly as shown in Figure 5-2.
5. Then remove control head seal, if required.

5.6.2 Top Cover Removal

1. Insert the dismantling tool between the top cover and the chassis as shown in Figure 5-3.
2. Press on the dismantling tool until one side wall of the top cover starts to clear the chassis trunnion mounting features.
3. Repeat step 2 for the other side of the top cover.
4. Lift the top cover from the chassis.

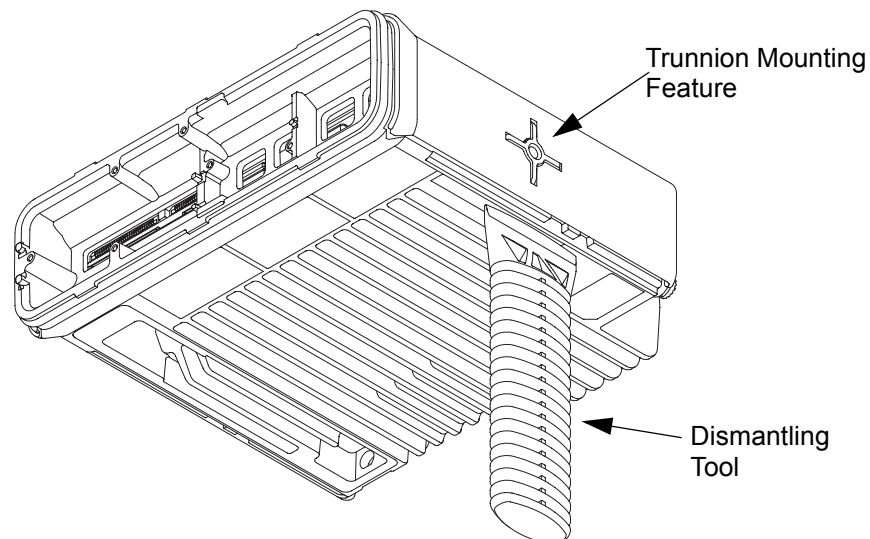

Figure 5-3 Top Cover Removal (Image May Not Match Exact Product)

5.6.3 Transceiver Board Removal

GPS Antenna Connector Removal

1. Using a T6 TORX™ driver, remove the screws securing the expansion board to the chassis.
2. Unplug the GPS cable MCX connector from the expansion board.

NOTE: Disconnect the MCX connector by grabbing and pulling on the MCX connector body and not the GPS cable itself.

3. Unplug the flex from the transceiver board.

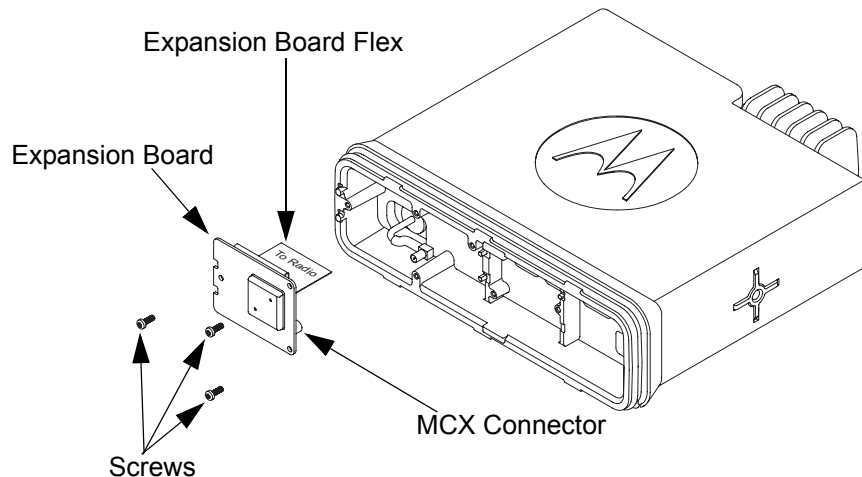

Figure 5-4 Expansion Board and Flex Removal (Image May Not Match Exact Product)

NOTE: Skip steps 4 through 6 if GPS cable and nameplate do not require servicing.

4. Use a flat-blade screwdriver to lift the GPS nameplate from the chassis. See Figure 5-5.

NOTE: If the GPS nameplate is removed it will need to be replaced.

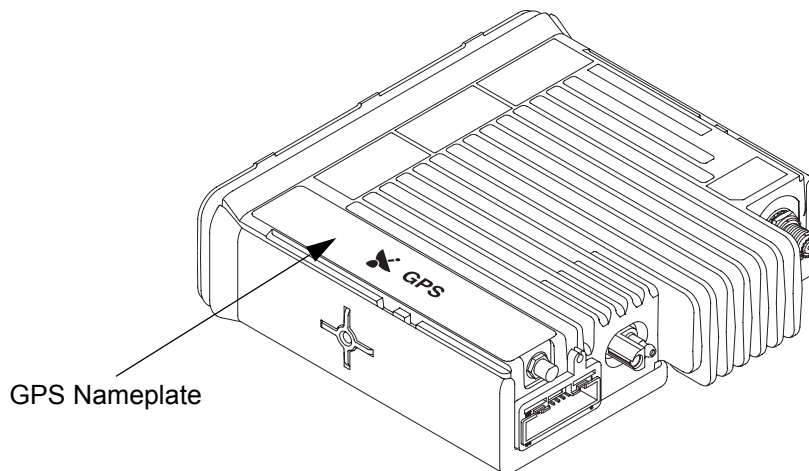

Figure 5-5 GPS Nameplate Removal

- Using a 5/16" or 8 mm socket driver, remove the nut from the GPS antenna connector and remove the lock washer from the connector. See Figure 5-6.

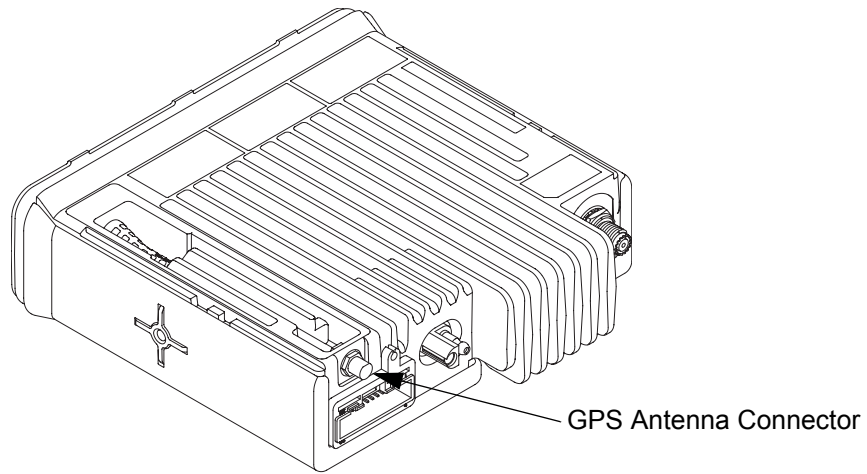

Figure 5-6 GPS Connector Nut Removal

- Remove the GPS cable from the chassis by pulling on the GPS cable strain relief.

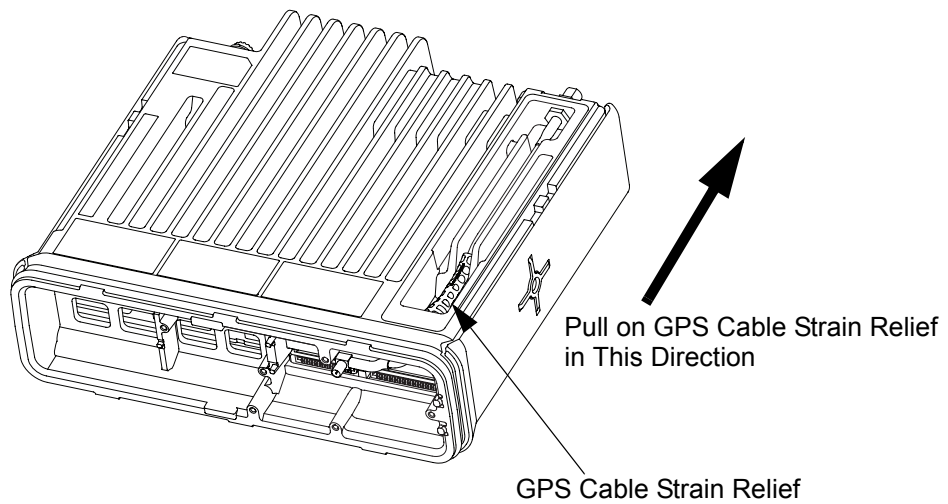

Figure 5-7 GPS Cable Removal

Option Board Removal

7. Using a T6 TORX™ driver, remove the screws securing the option board to the chassis.
8. Unplug the flex from the transceiver board.

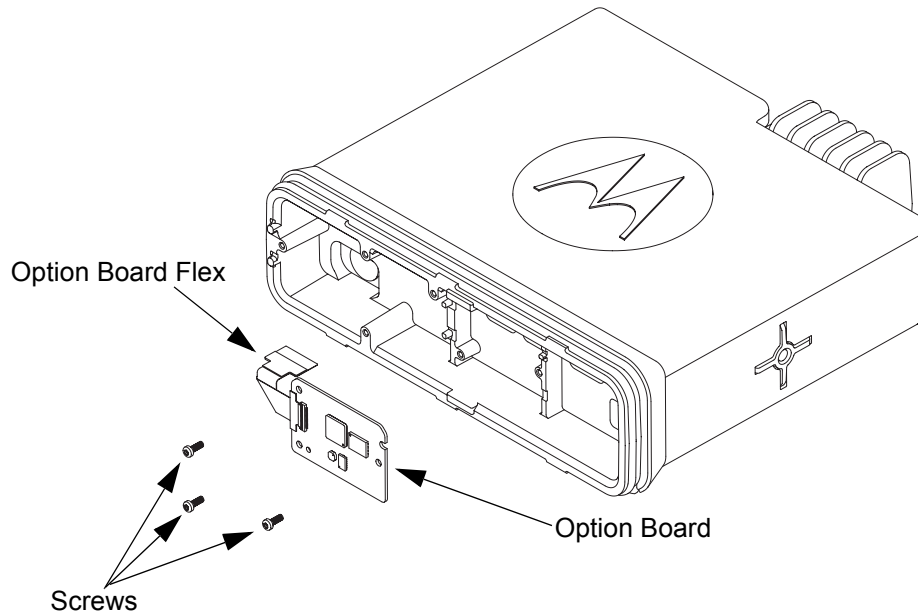

Figure 5-8 Option Board Removal (Image May Not Match Exact Product)

Transceiver Board Removal

9. Remove the acoustic plug by pulling up on it.

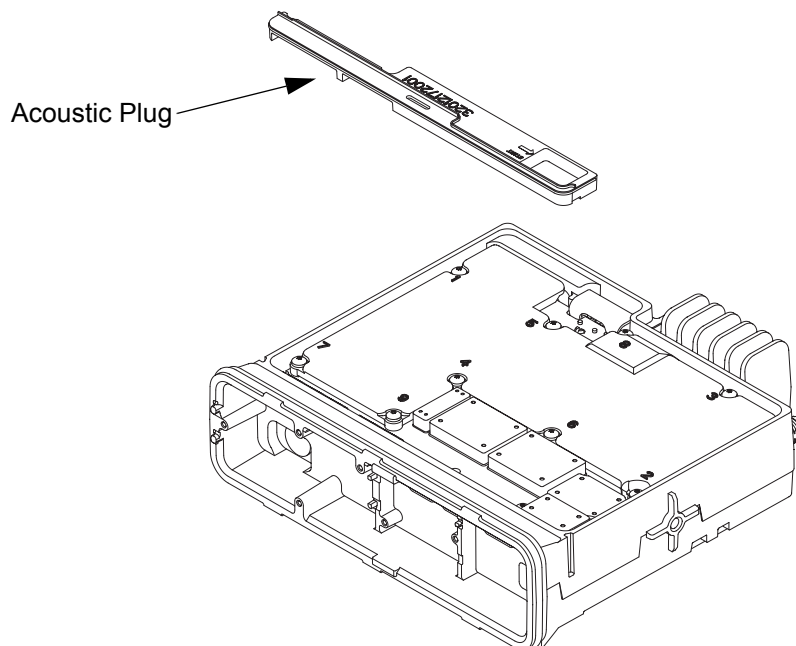

Figure 5-9 Acoustic Plug Removal

10. Remove the nine screws from the die cast main shield and the one screw directly on the PCB using the T10 TORX™ driver as shown in Figure 5-10.
11. Lift the die cast main shield from the chassis.

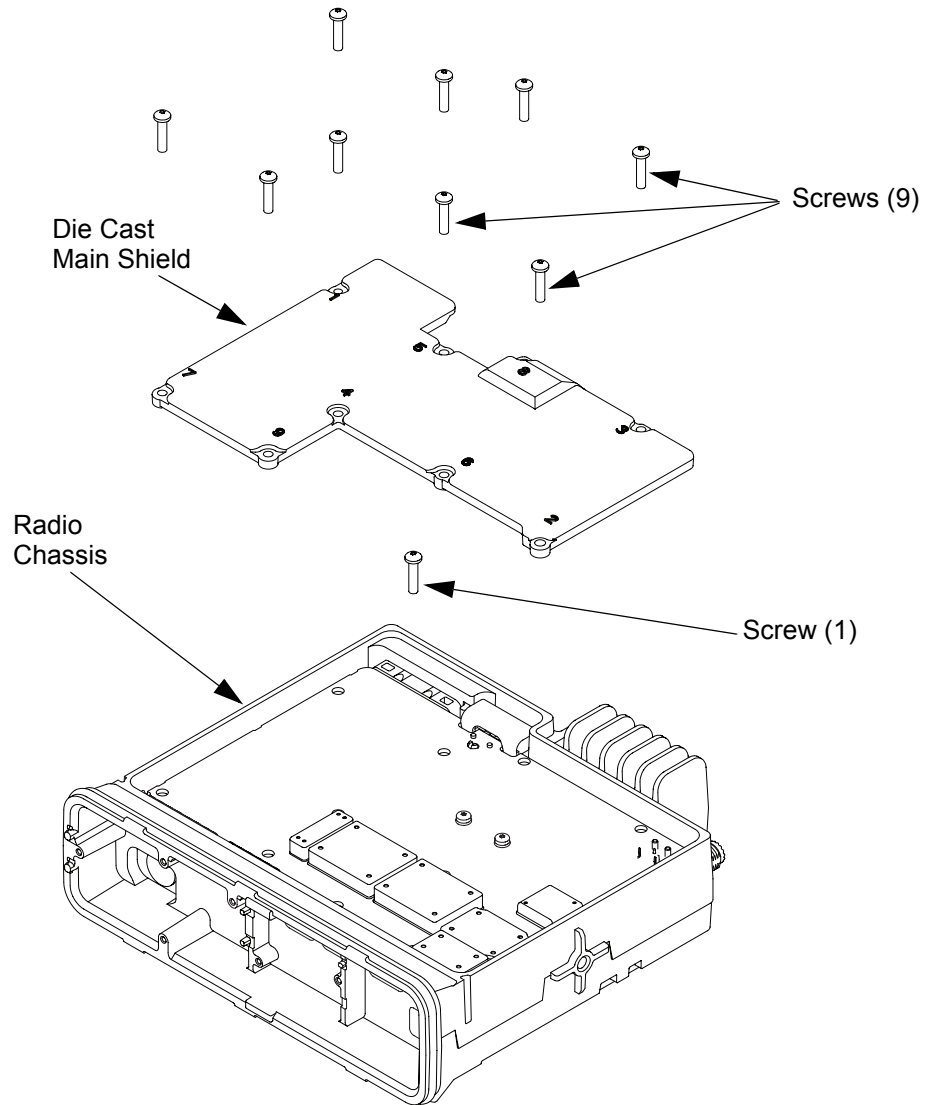

Figure 5-10 Die Cast Main Shield Removal

12. Remove the two screws from the PCB using the T8 TORX™ driver as shown in Figure 5-11.

NOTE: Do not remove the washers from the screws.

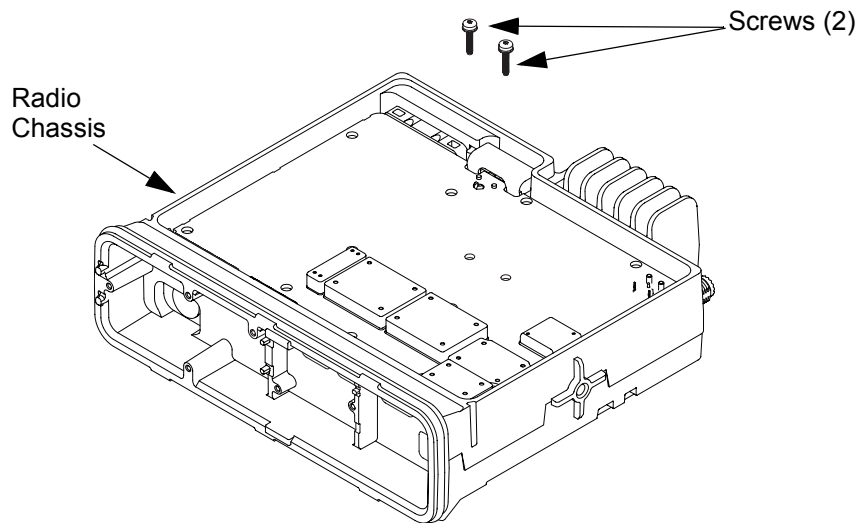

Figure 5-11 PA Screw Removal

13. Remove the accessory connector from the radio assembly by inserting a flat-blade screwdriver into the slot on the top of the connector as shown in Figure 5-12.



Caution

The accessory connector should never be removed when the die cast main shield is still assembled to the radio.

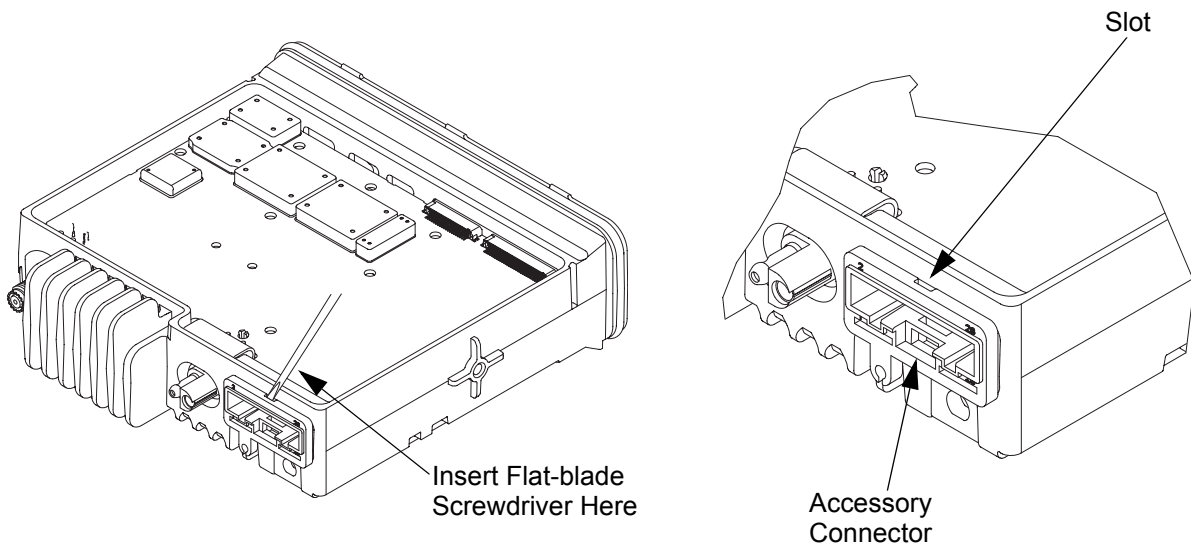

Figure 5-12 Accessory Connector Removal

14. Remove the DC Connector retention clip by gently prying it out with a flat-blade screwdriver as shown in Figure 5-13.

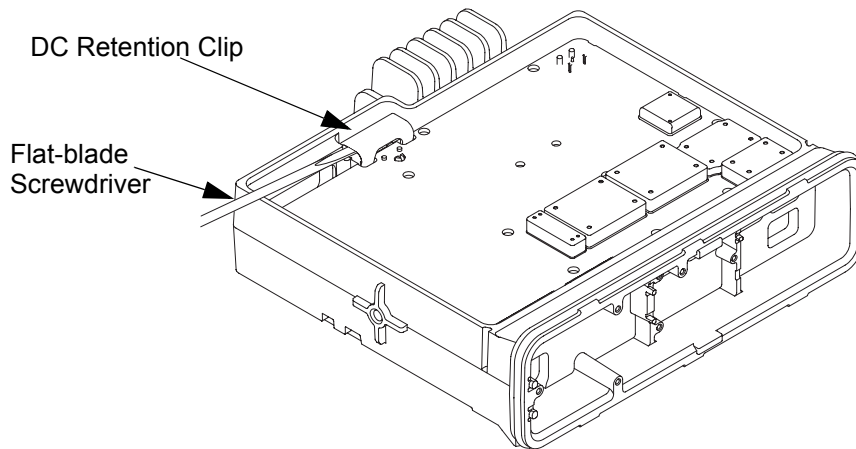

Figure 5-13 DC Connector Retention Clip Removal

15. Remove the RF connector nut and lock washer using a 9/16" deep socket driver (Figure 5-14).

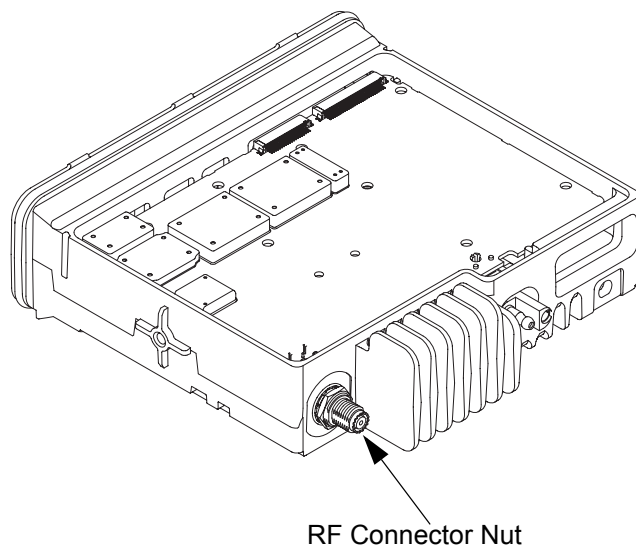



Figure 5-14 RF Connector Nut Removal

16. Remove the transceiver board by sliding a finger into the opening provided at the front of the radio and gently pressing up on the PCB between the connectors, lifting up the front of the transceiver board, as shown in Figure 5-15. Then, slide the transceiver board towards the front of the radio to allow the RF/DC connectors to clear the chassis. Handle the transceiver board by the edges only and store it in an antistatic bag.

NOTE: If the RF/DC connector gaskets remain in the chassis, remove them and place them back on the connectors. Every time the Transceiver Board is removed, the Final Driver Thermal Pad must be replaced.

	The thermal pads can act as an adhesive and cause stress to critical components on the transceiver board if the transceiver board is lifted too quickly.
Caution	

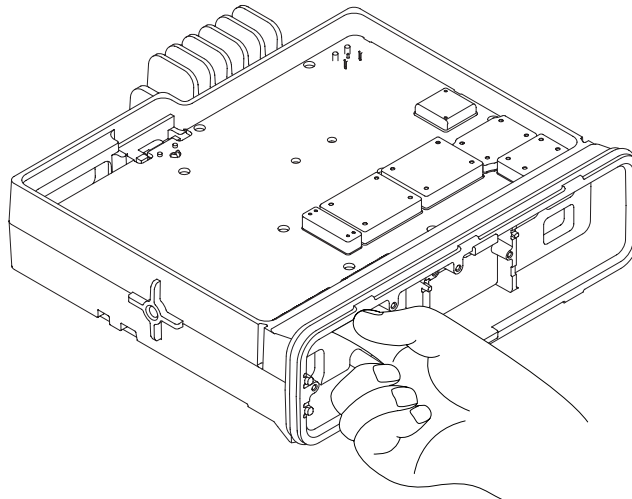

Figure 5-15 Transceiver Board Removal

5.6.4 Disassembly of Color Display Control Head

1. Disconnect the speaker plug from the control head board.
2. Unplug the control head flex from the control head board by gently pulling the flex out of the connector.

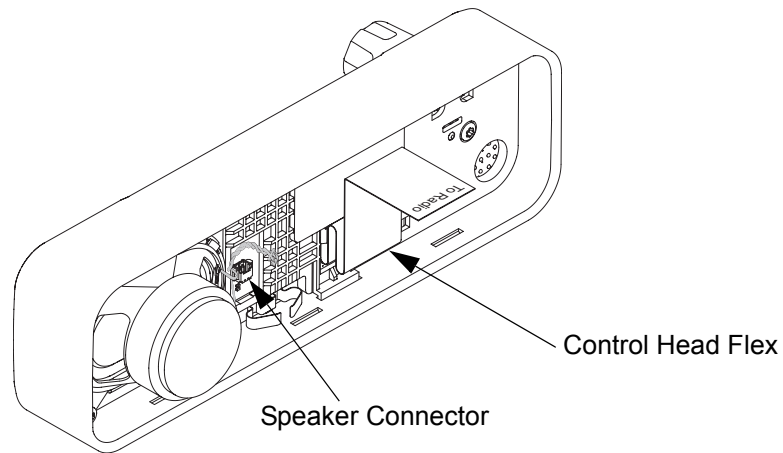

Figure 5-16 Control Head Flex Removal

3. Remove the volume/channel knob from the control head housing by lifting it with the volume/channel knob removal tool.

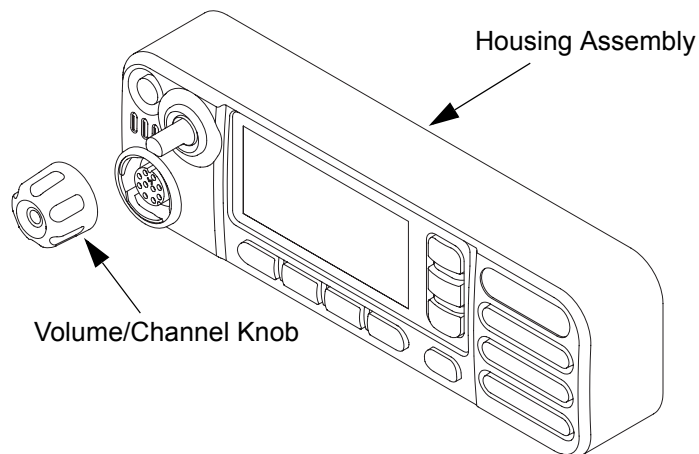

Figure 5-17 Volume/Channel Knob Removal

4. Remove the five screws from the control head board using the T10 TORX™ driver.
5. Remove the speaker.

NOTE: Remove the speaker retainer only if required.

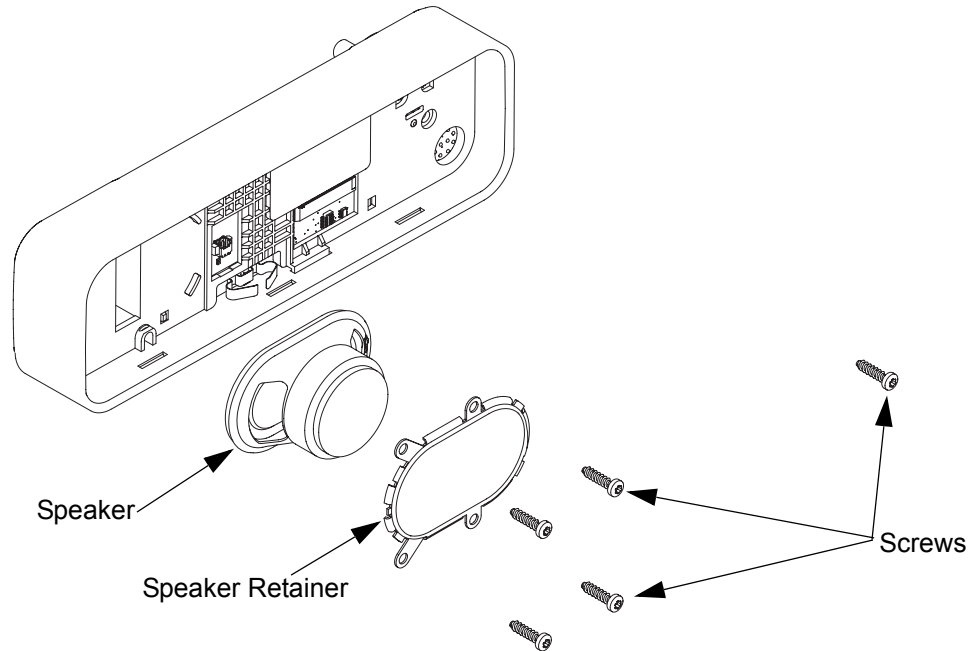

Figure 5-18 Control Head Screws and Speaker Removal

6. Gently spread the side walls of the control head housing to release the PCB retainer tabs from the housing.

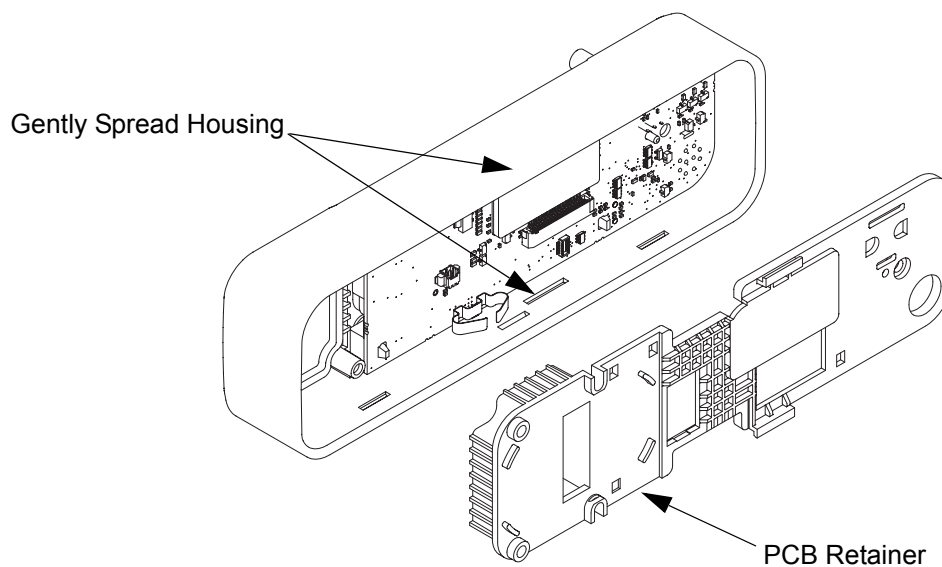

Figure 5-19 PCB Retainer Removal

7. Remove the control head board from the control head assembly by pressing on the keypad buttons and mic jack. Handle the control head board by the edges only and store it in an antistatic bag.

NOTE: Do not touch or contaminate the conductive contacts on the control head PCB.

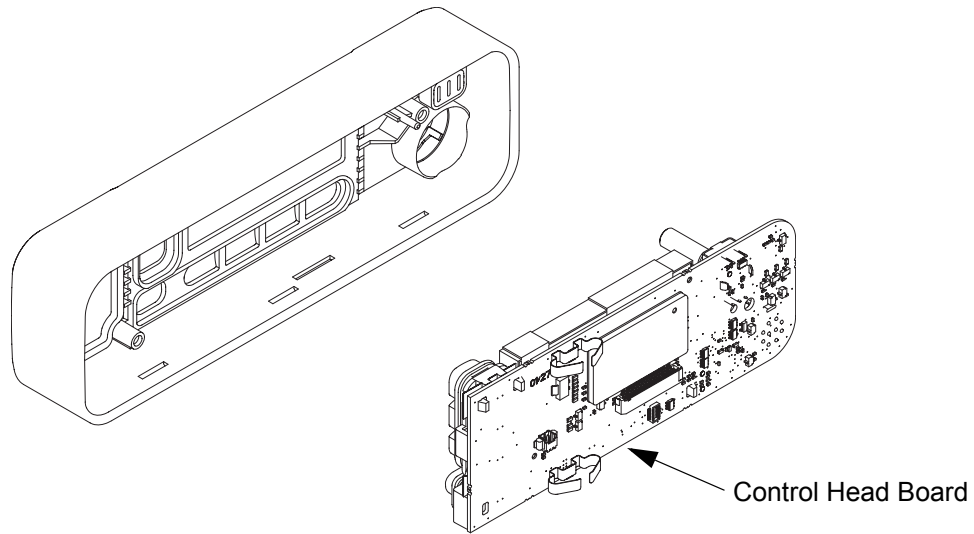

Figure 5-20 Control Head Board Removal

8. Remove the power button by lifting it from the control head housing.
9. Separate the light barrier from the power button, if required.

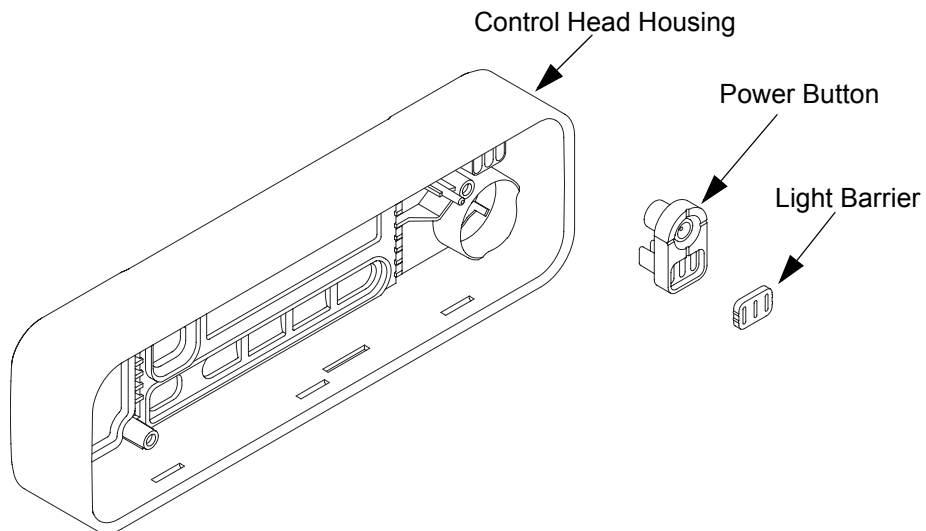

Figure 5-21 Power Button Removal

10. Separate the keypad from the keypad frame.
11. Remove the keypad frame from the control head board by compressing the retaining latch features.

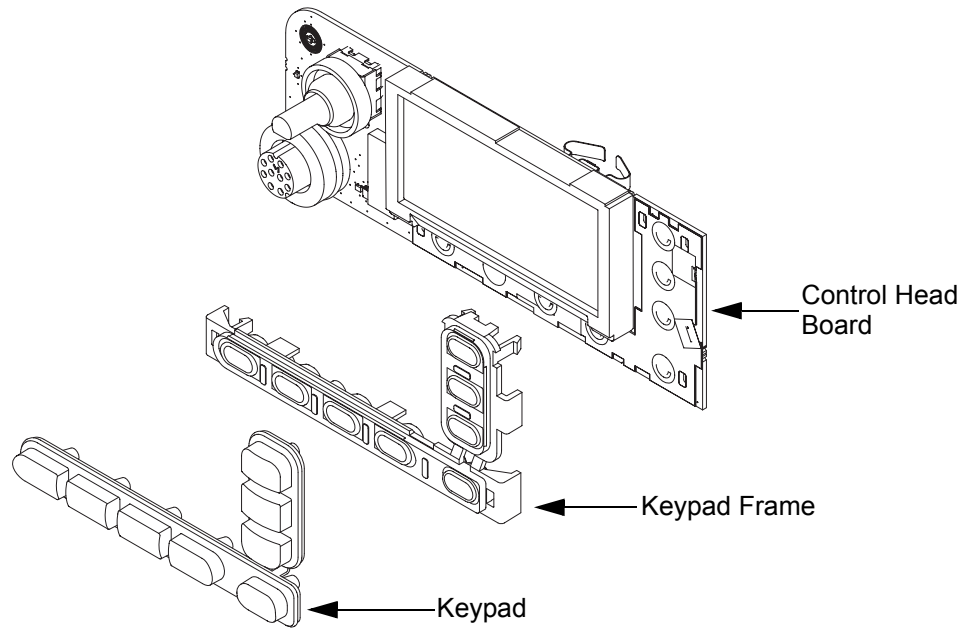

Figure 5-22 Keypad Removal

12. Separate the volume encoder seal and mic jack seal from the control head board.

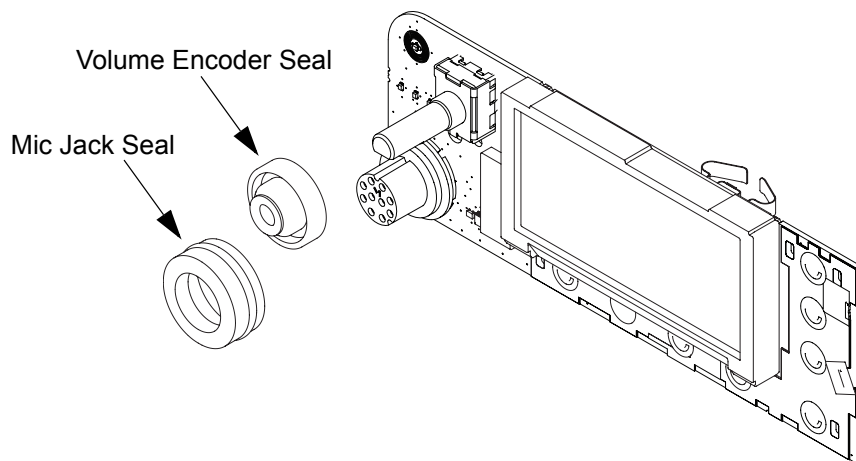

Figure 5-23 Volume Encoder Seal and Mic Jack Seal Removal

13. Separate the display pad gasket from the color display.

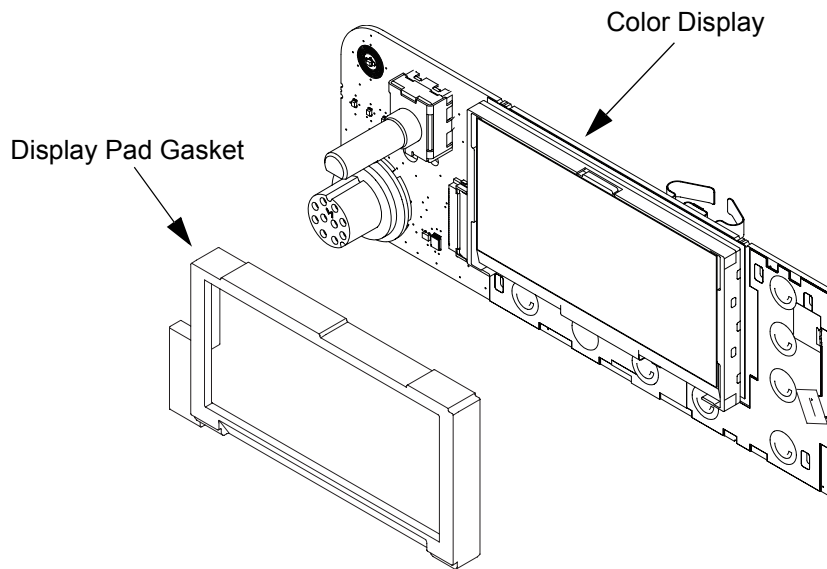

Figure 5-24 Display Pad Gasket Removal

14. Disconnect the display flex from the connector on the PCB.
15. Gently pull or lift on one side of the display to slowly separate the display from the adhesive.

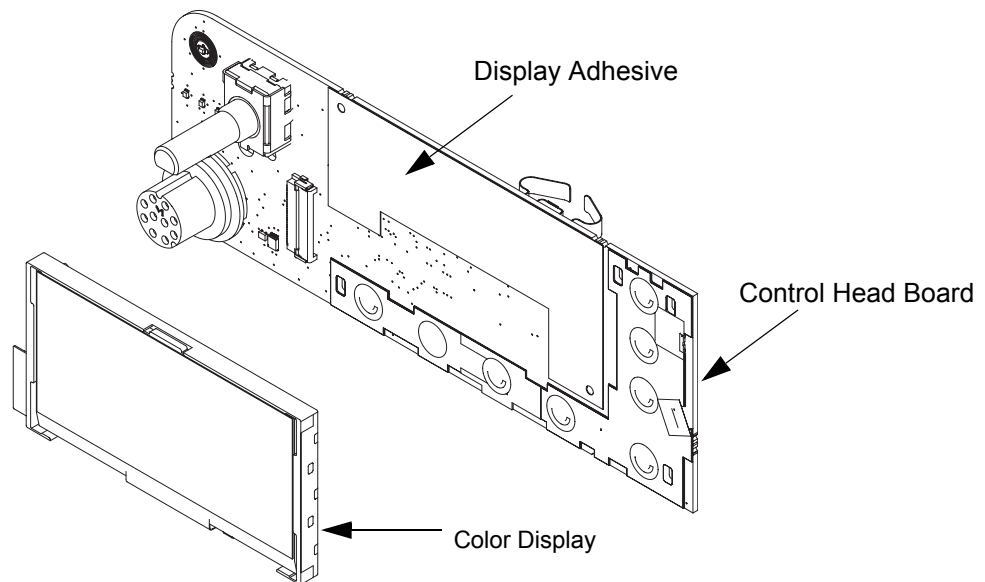

Figure 5-25 Color Display Removal from PCB

5.6.5 Disassembly of Numeric Display Control Head

1. Disconnect the speaker plug from the control head board.
2. Unplug the control head flex from the control head board by gently pulling the flex out of the connector.

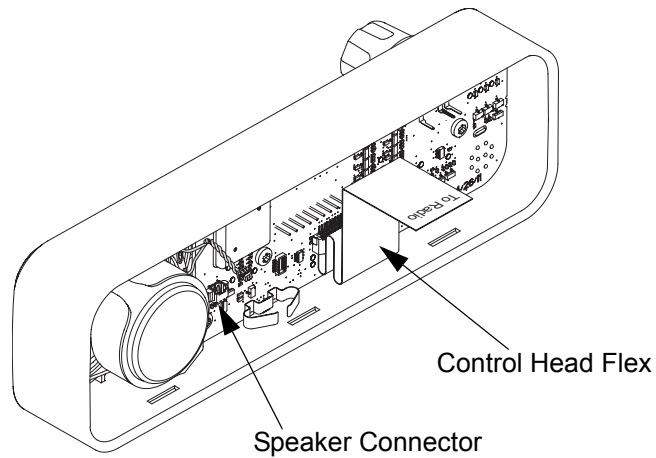

Figure 5-26 Control Head Flex Removal

3. Remove the volume/channel knob from the control head housing by lifting it with the volume/channel knob removal tool.

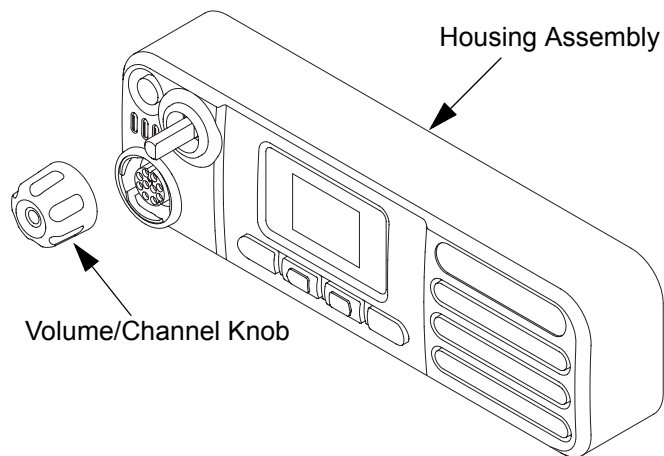

Figure 5-27 Volume/Channel Knob Removal

4. Remove the seven screws from the control head board using the T10 TORX™ driver.
5. Remove the control head board from the control head assembly by pressing on the mic jack. Handle the control head board by the edges only and store it in an antistatic bag.

NOTE: Do not touch or contaminate the conductive contacts on the control head board.

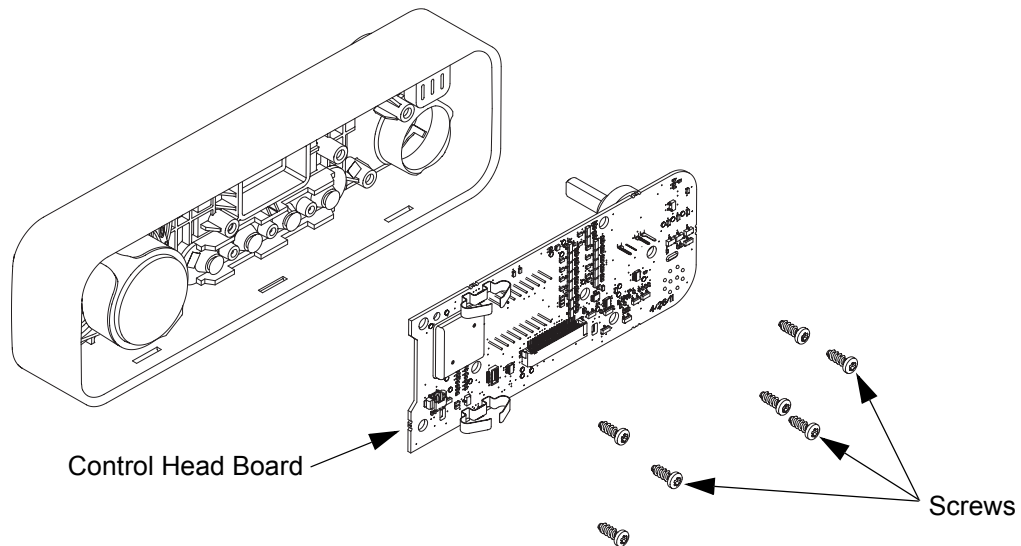

Figure 5-28 Control Head Board Removal

6. Remove the power button by lifting it from the control head housing.
7. Separate the light barrier from the power button, if required.
8. Remove the keypad assembly from the control head housing by pushing on the keypad.
9. Separate the keypad from the keypad frame.

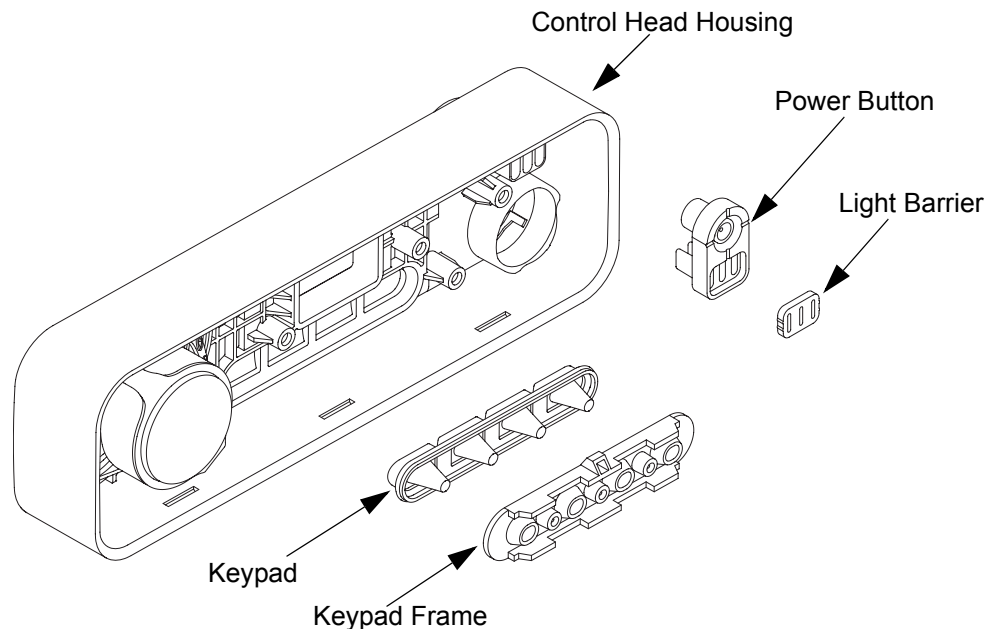

Figure 5-29 Power Button and Keypad Removal

10. Optional: If required, the speaker can be removed by removing the speaker retainer from the control head housing using the T10 TORX™ driver to remove the screw and unhook the retainer from the control head housing.

11. Remove the speaker from the control head housing.

NOTE: Remove the speaker retainer only if required.

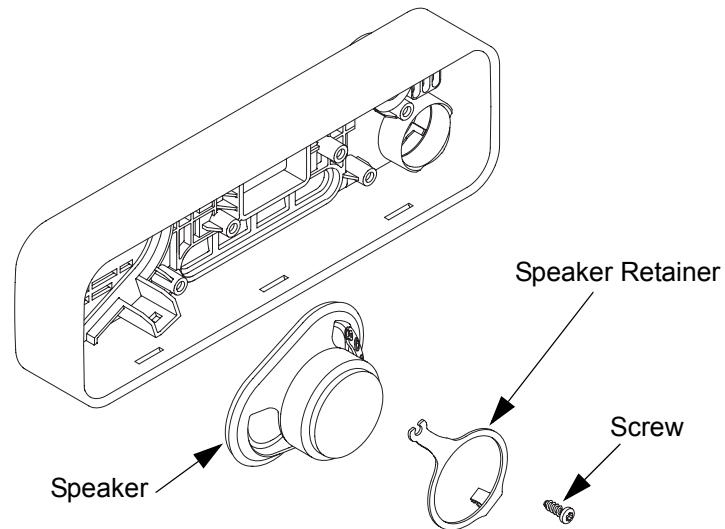

Figure 5-30 Speaker Removal (Optional)

12. Separate the volume encoder seal and mic jack seal from the control head board.

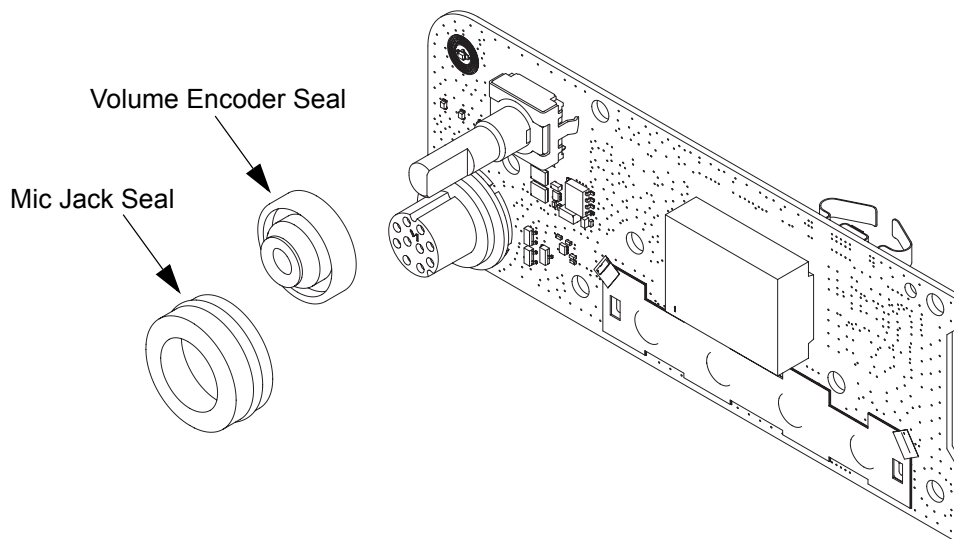

Figure 5-31 Volume Encoder Seal and Mic Jack Seal Removal

5.7 Radio Reassembly – Detailed

5.7.1 Color Display Control Head

1. Assemble the power button and light barrier and then place the subassembly inside the control head housing. Refer to Figure 5-32.

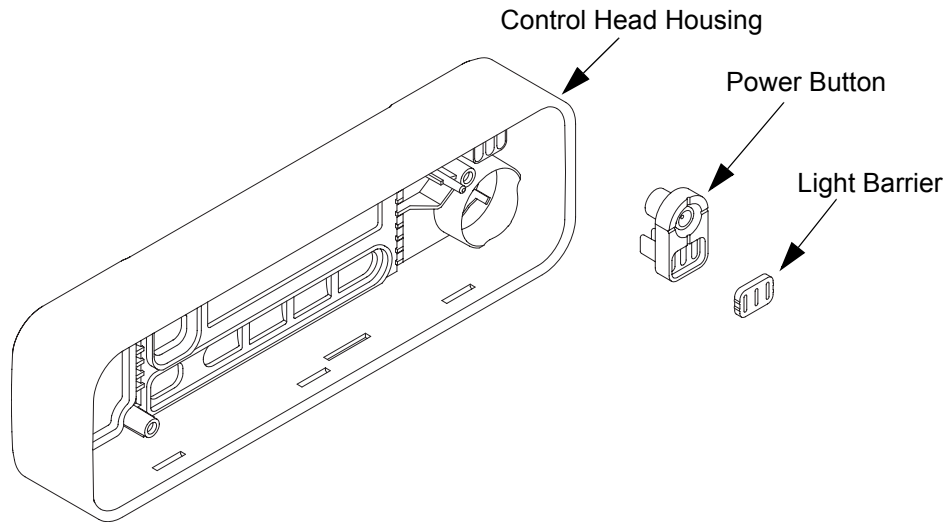

Figure 5-32 Power Button Placement

2. Assemble the keypad to the keypad frame. Refer to Figure 5-33.
 - a. If attached to the control head board, remove by compressing the retaining latch features.

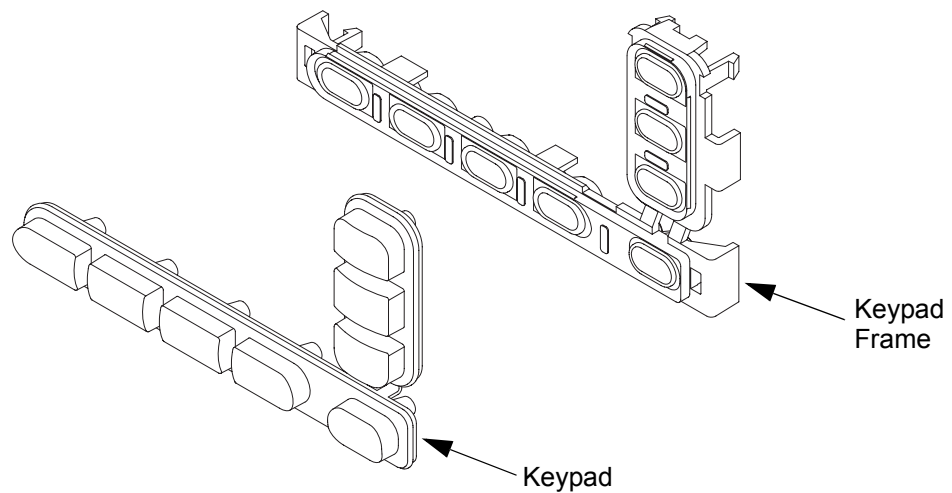

Figure 5-33 Keypad Assembly

3. Assemble the keypad frame assembly and volume encoder seal to the control head housing until fully seated. Refer to Figure 5-34.

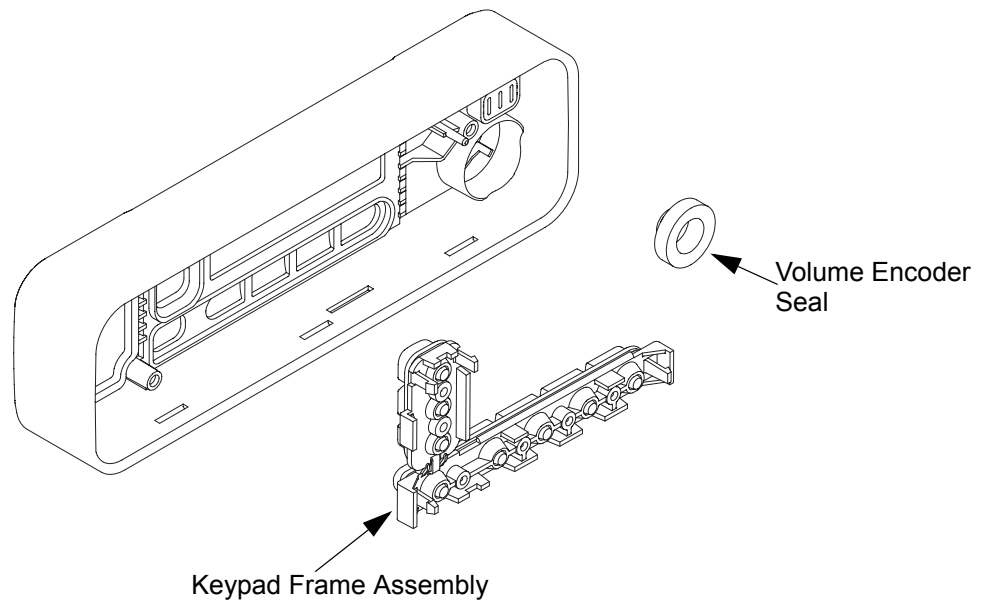

Figure 5-34 Assembly to Control Head Housing

4. Align the color display alignment pins to the PCB holes.
5. Firmly press along the outer perimeter of the display to activate the adhesion of the display to the display adhesive.
6. Connect the display flex to the connector on the PCB.

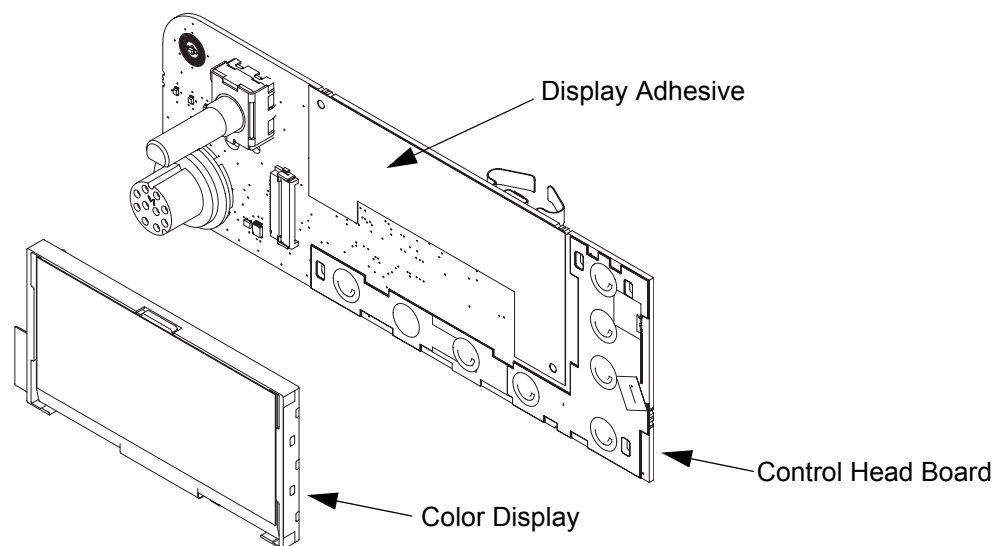

Figure 5-35 Assembling Color Display to PCB

7. Assemble the mic jack seal around the mic jack as shown in Figure 5-36. Be sure to place mic jack seal flush to the PCB.

NOTE: Make sure the mic jack is free from dust or debris.

8. Assemble the display pad gasket to the display.

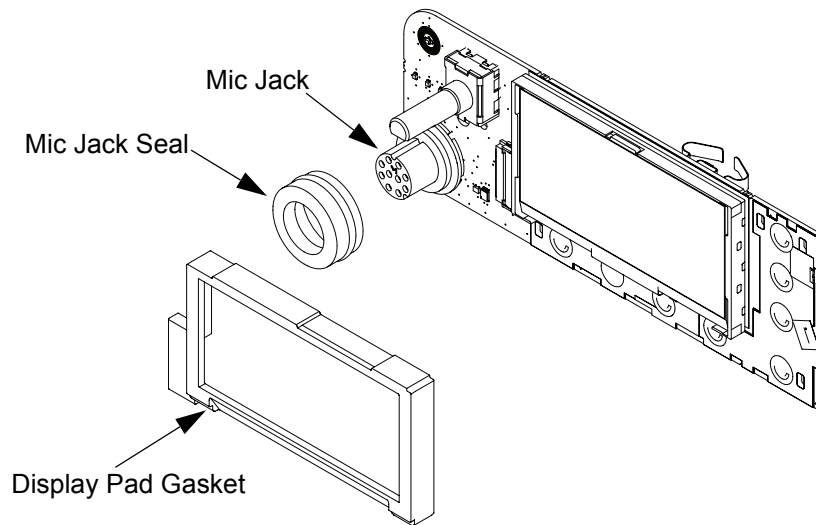

Figure 5-36 Assembling Mic Jack Seal and Display Pad Gasket

9. Assemble the control head flex to the mating connector on the control head board, making sure it is fully seated as shown in Figure 5-37.
10. Assemble the control head board to the control head assembly.

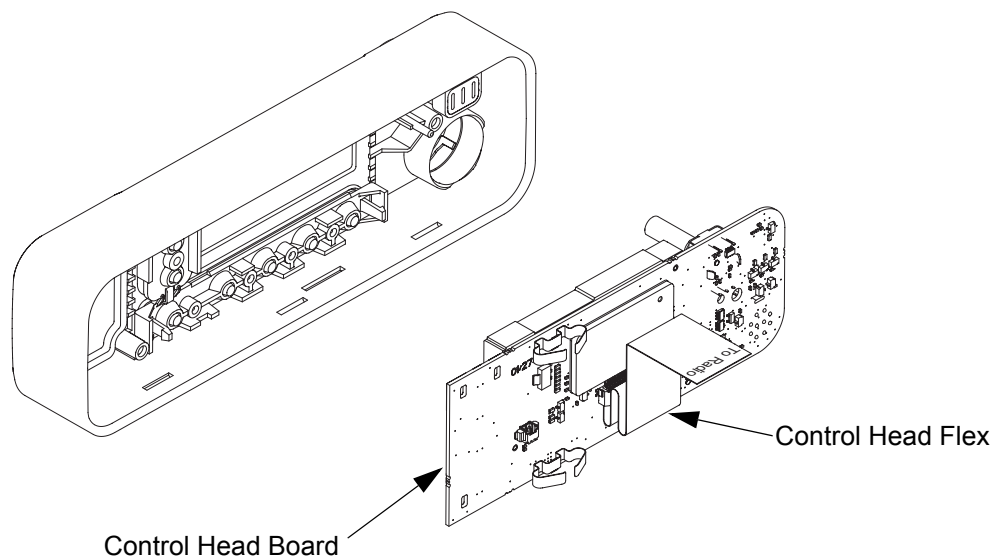

Figure 5-37 Assembling Control Head Board to Control Head Assembly

11. Assemble the PCB retainer to the control head assembly until it is fully seated. You will need to feed the control head flex through the PCB retainer.

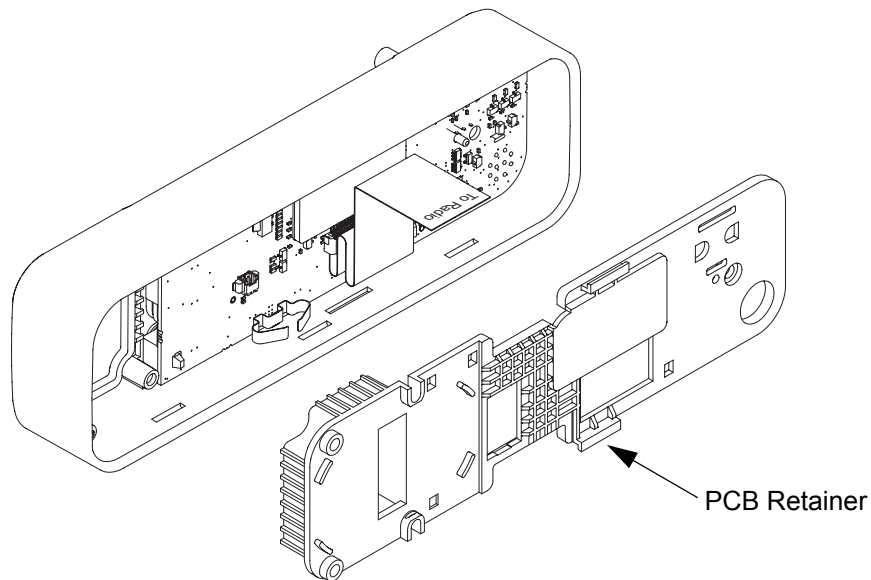

Figure 5-38 Assembling PCB Retainer

12. Assemble the speaker retainer to the speaker. It will snap over the speaker magnet. See Figure 5-39.
- NOTE:** Be sure to orient the speaker in the direction of the wire and connector towards the middle of the control head. See Figure 5-40.
13. Assemble the speaker to the control head assembly. Assemble the screws in a cross pattern with the single PCB screw installed last.
 14. Connect the speaker plug to its mating connector on the control head board.

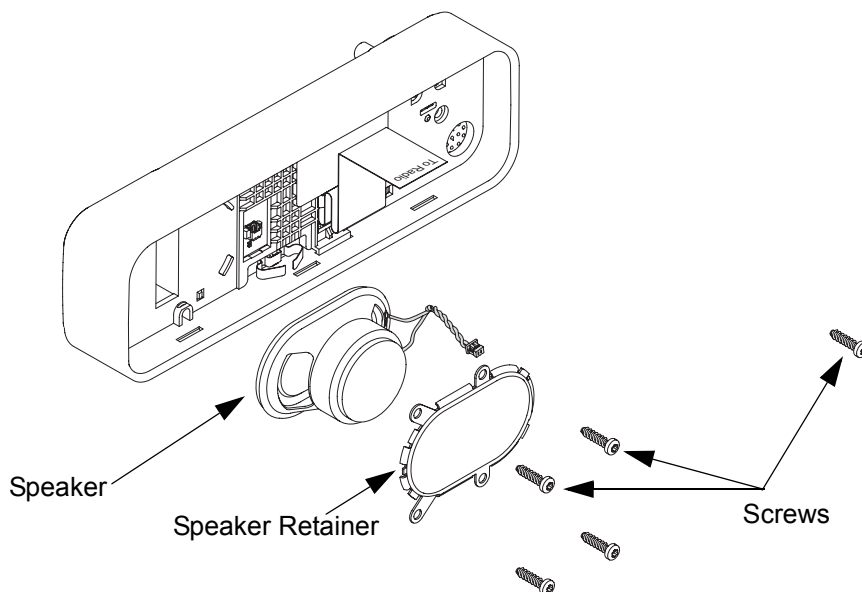

Figure 5-39 Assembling Speaker

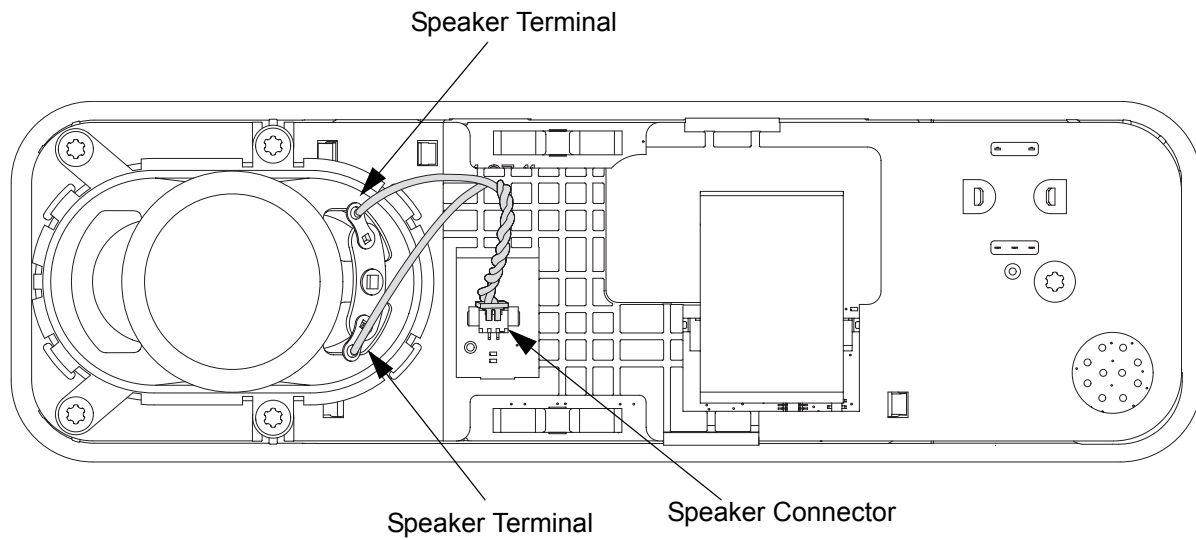

Figure 5-40 Orientation of Speaker

15. Orientate the volume/channel knob so that the internal D-shaped opening matches the volume encoder shaft and press the volume/channel knob into the control head assembly until it is fully seated and the knob rotates freely. Refer to Figure 5-41.

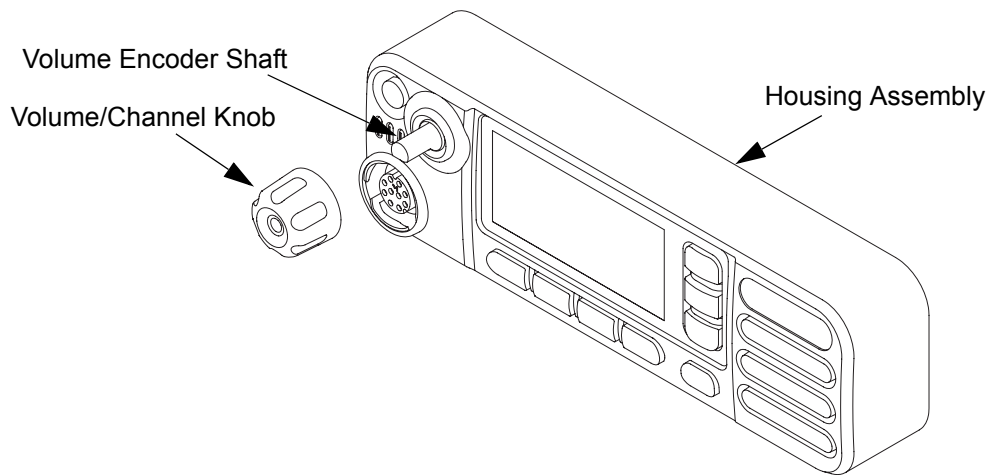

Figure 5-41 Volume/Channel Knob Assembly

5.7.2 Numeric Display Control Head

1. Assemble the power button and light barrier and then place the subassembly inside the control head housing. Refer to Figure 5-42.

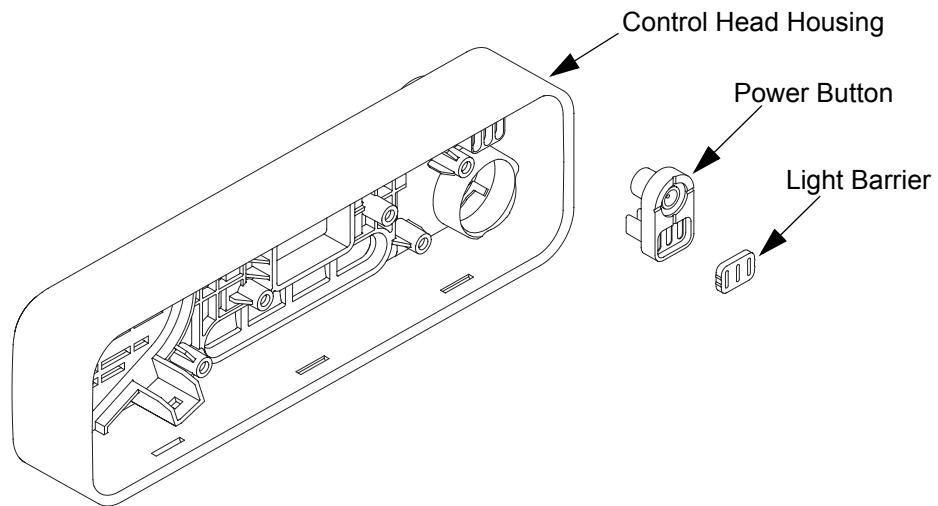

Figure 5-42 Power Button Placement

2. Assemble the keypad to the keypad frame. Refer to Figure 5-43.

Note Orientation of Keypad to Keypad Frame

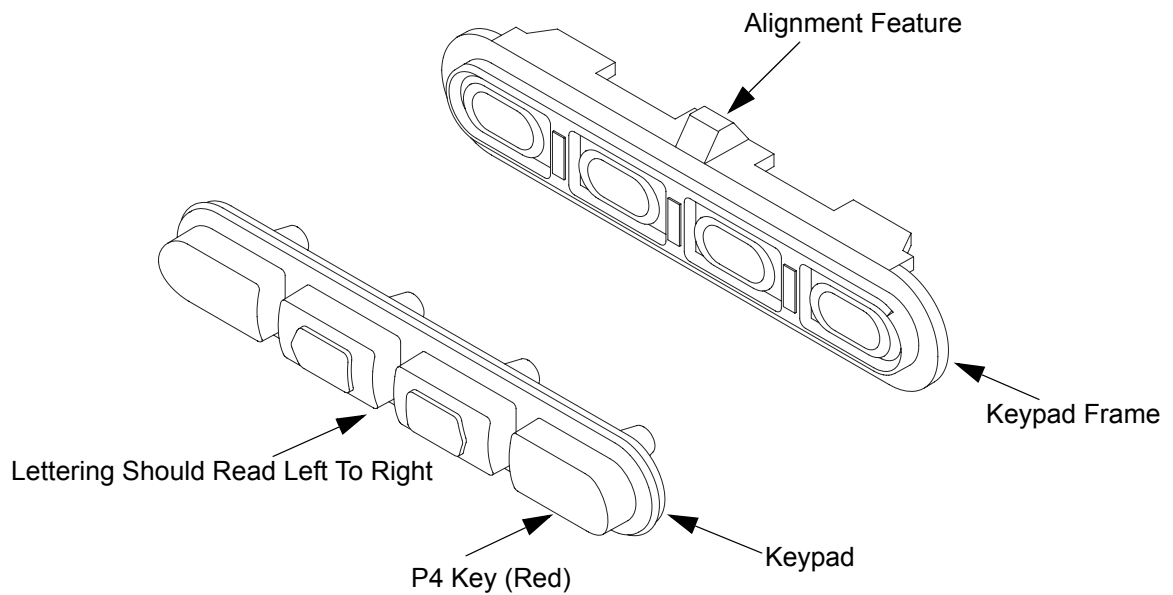

Figure 5-43 Keypad Assembly

3. Assemble the keypad frame assembly and volume encoder seal to the control head housing until they are fully seated. Refer to Figure 5-44.

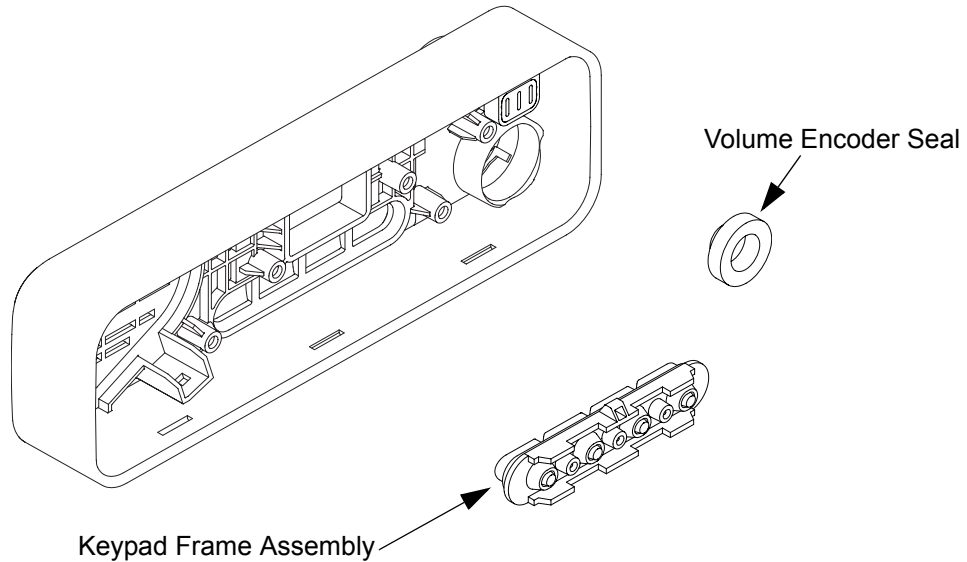

Figure 5-44 Assembly to Control Head Housing

4. Assemble the mic jack seal around the mic jack as shown in Figure 5-45. Be sure to place mic jack seal flush to the PCB.

NOTE: Make sure the mic jack is free from dust or debris.

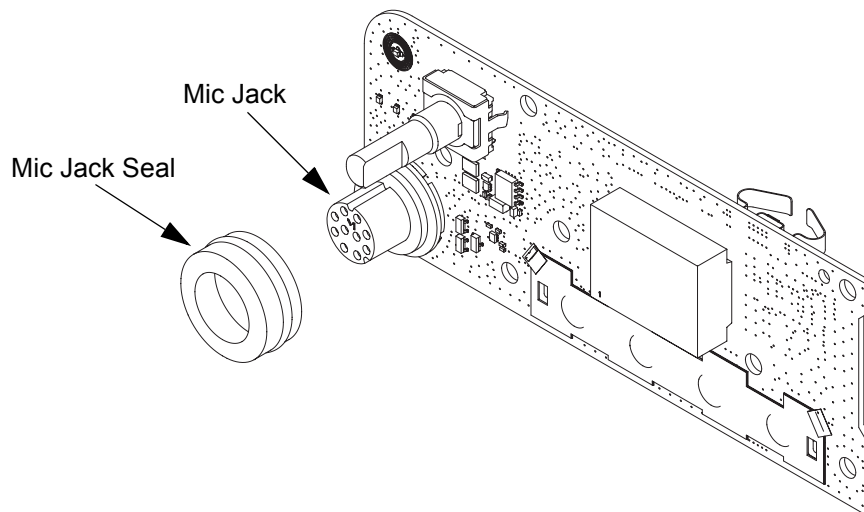

Figure 5-45 Assembling Mic Jack Seal

5. Assemble the speaker retainer to the speaker. It will snap over the speaker magnet. See Figure 5-46.

NOTE: Be sure to orient the speaker in the direction of the wire and connector towards the middle of the control head.

6. Assemble the speaker to the control head assembly.

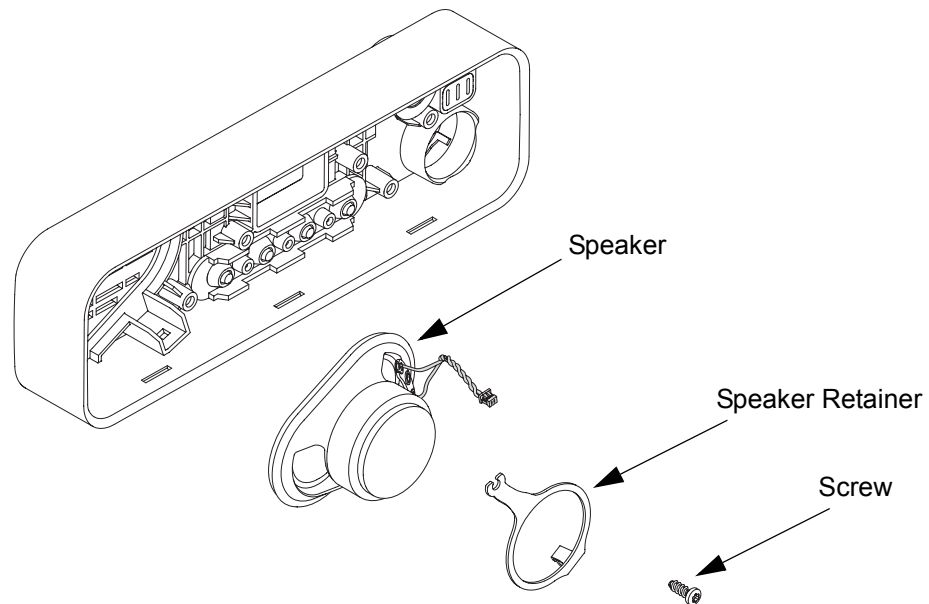

Figure 5-46 Assemble Speaker

7. Hook one side of the speaker retainer into the control head assembly as shown in Figure 5-47.
8. Place a screw into the other end of the speaker retainer and using a T10 TORX™ driver, tighten the screw to 0.88 N-m (7.8 lbs-in).

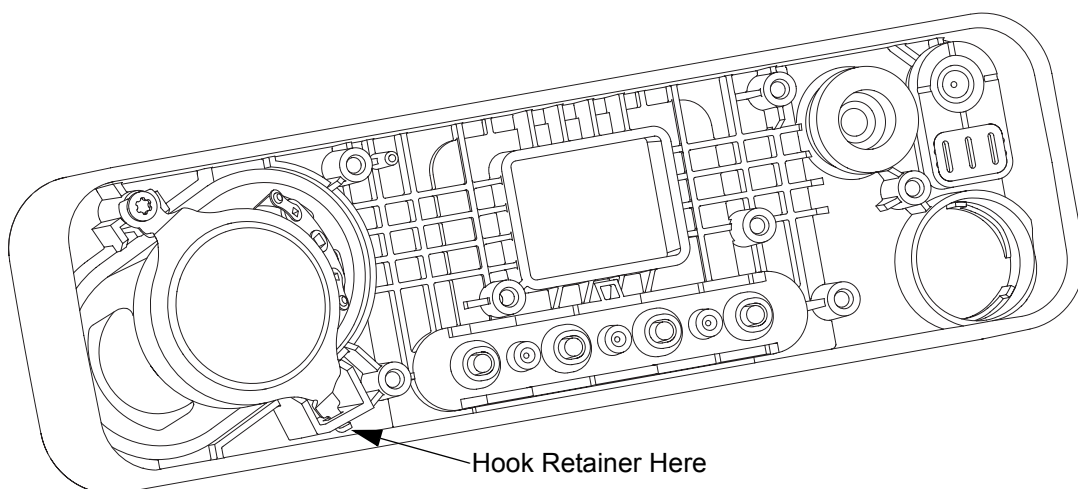

Figure 5-47 Speaker Retainer Assembly

9. Assemble the control head flex to the mating connector on the control head board, making sure it is fully seated as shown in Figure 5-48.
10. Assemble the control head board to the control head assembly.

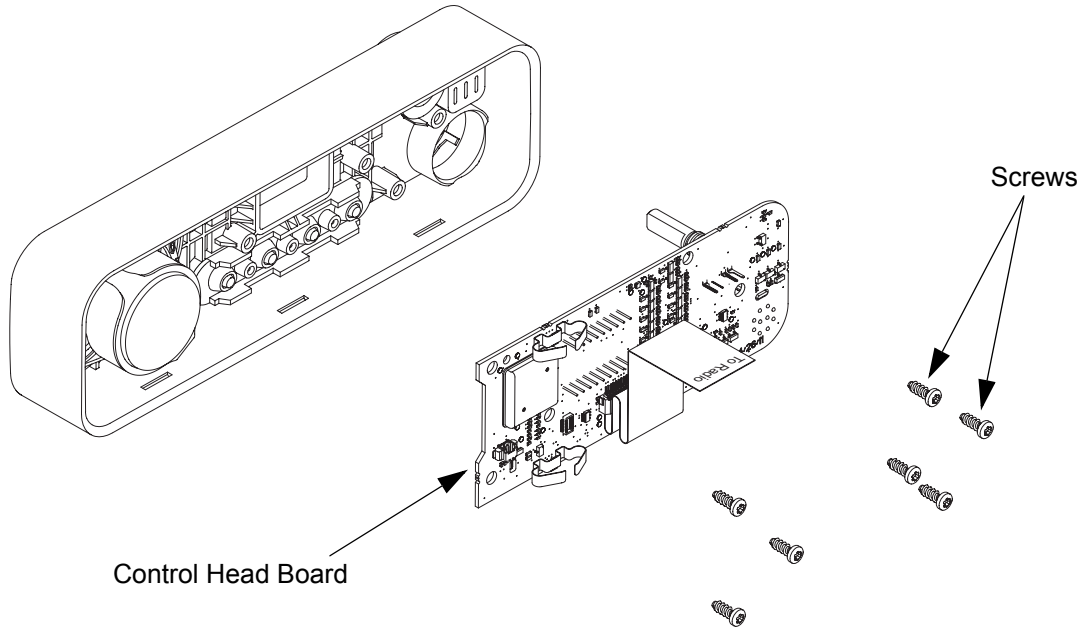

Figure 5-48 Assembling Control Head Board to Control Head Assembly

11. Using a T10 TORX™ driver, tighten the seven screws to 0.88 N-m (7.8 lbs-in) following the sequence as shown in Figure 5-49.
12. Connect the speaker plug to its mating connector on the control head board.

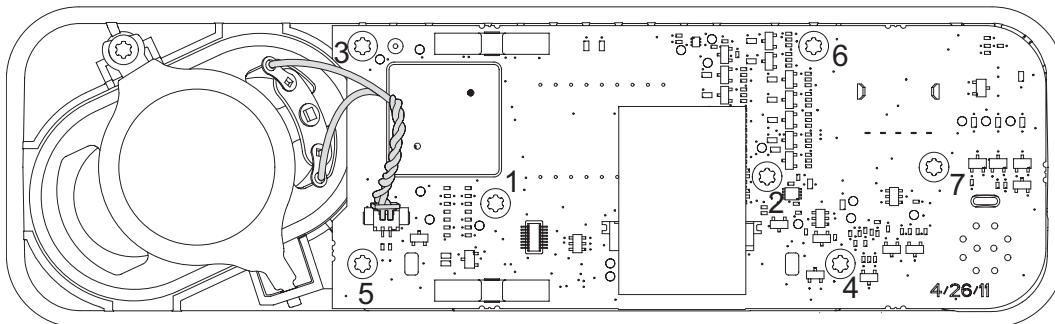

Figure 5-49 Screw Sequence

13. Orientate the volume/channel knob so that the internal D-shaped opening matches the volume encoder shaft and press the volume/channel knob into the control head assembly until it is fully seated and the knob rotates freely. Refer to Figure 5-50.

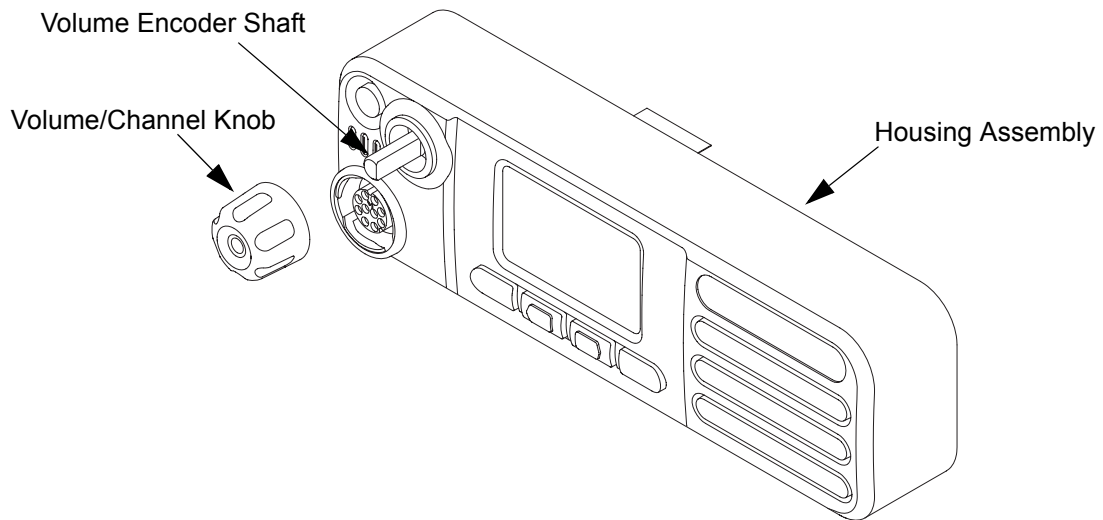

Figure 5-50 Volume/Channel Knob Assembly

5.7.3 Radio Assembly

1. Prior to reassembling the radio, inspect all seals and sealing surfaces for damage (nicks, cuts, etc.) or debris. Refer to the exploded view and bill of materials for the correct part numbers and replace parts, as necessary. Replace all new seals on their respective parts.

For both the die cast main shield and the chassis, thoroughly inspect the shield gasketing for damage and verify all thermal pads are in place and free from damage and debris. See Section 5.7.4: Thermal Pad Replacement Procedure on page 5-33 to replace damaged pads.

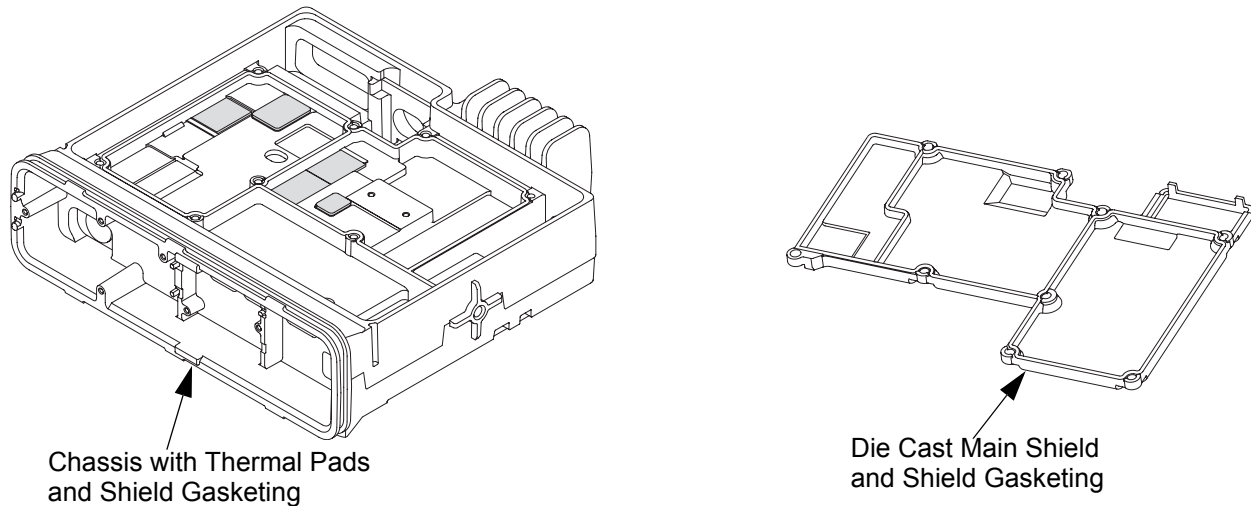

Figure 5-51 Thermal Pads and Shield Gasketing on Chassis and Die Cast Main Shield

2. Thoroughly inspect the chassis and verify all thermal pads are in place and free from damage. See Section 5.7.4: Thermal Pad Replacement Procedure on page 5-33 to replace damaged pads.

NOTE: Every time the Transceiver Board is removed, the Final Driver Thermal Pad must be replaced.

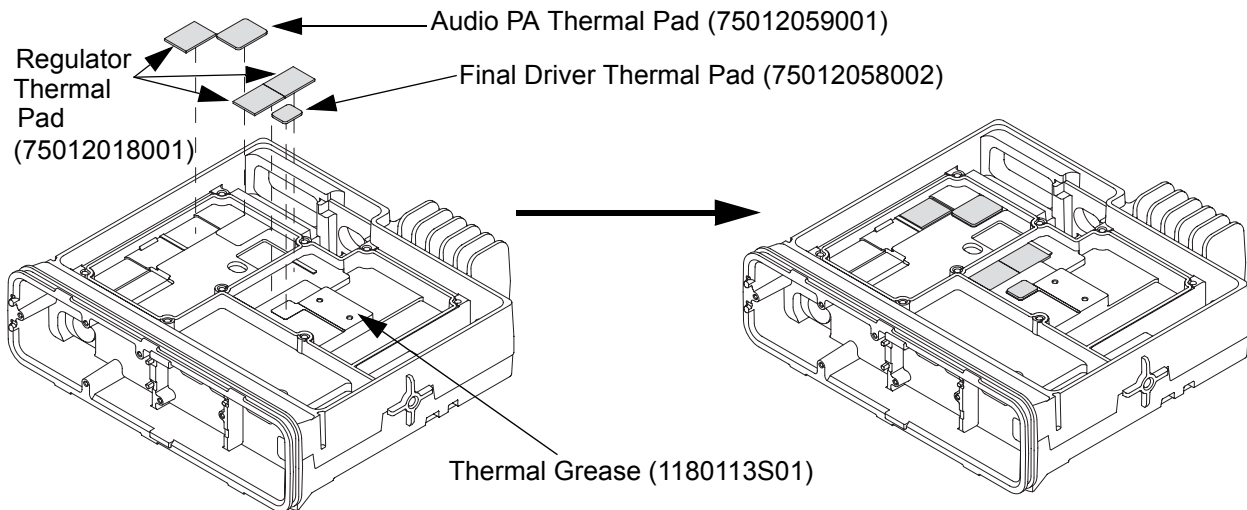

Figure 5-52 Chassis with Thermal Pads

5.7.4 Thermal Pad Replacement Procedure

Regulator Thermal Pad Replacement

1. Use a plastic flat-edge tool to lift the pad from the chassis surface. Discard the old pad.
2. Use a soft cloth to remove any remaining residue. Alcohol can also be used, if necessary. Care should be taken to minimize any cleaning-agent contact with the surrounding shield gasket.
3. Once the surface is clean and dry, remove the new pad from the shipping liner, and place it on the chassis as shown in Figure 5-53.

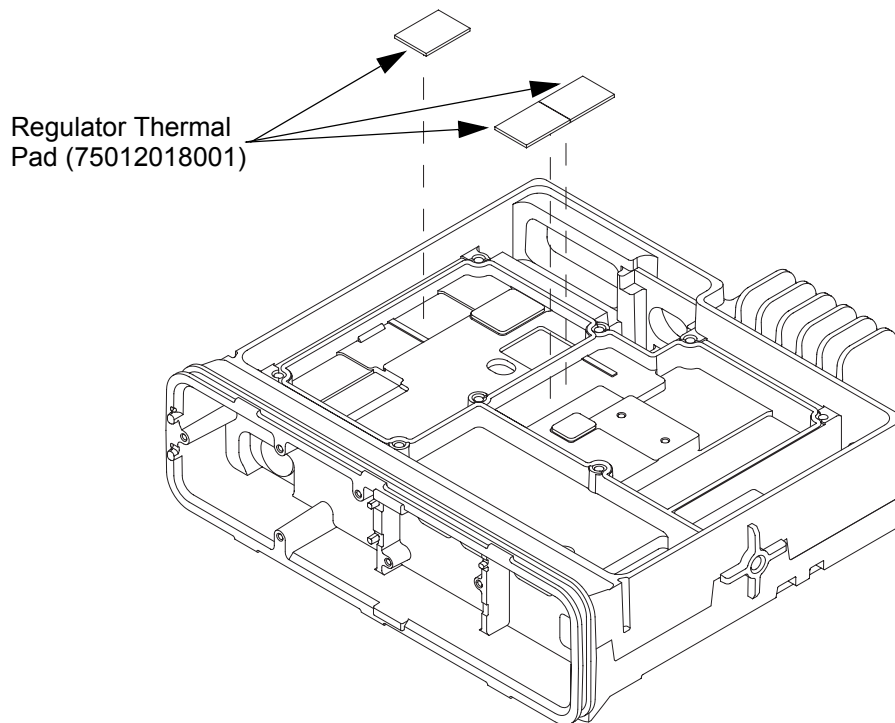

Figure 5-53 Replacing Regulator Thermal Pads

Audio PA Thermal Pad Replacement

1. Use a plastic flat-edge tool to lift the pad from the chassis surface. Discard the old pad.
2. Use a soft cloth to remove any remaining residue. Alcohol can also be used, if necessary. Care should be taken to minimize any cleaning-agent contact with the surrounding shield gasket.

3. Once the surface is clean and dry, remove the new pad from the shipping liner, and place the pad on to the chassis as shown in Figure 5-54.

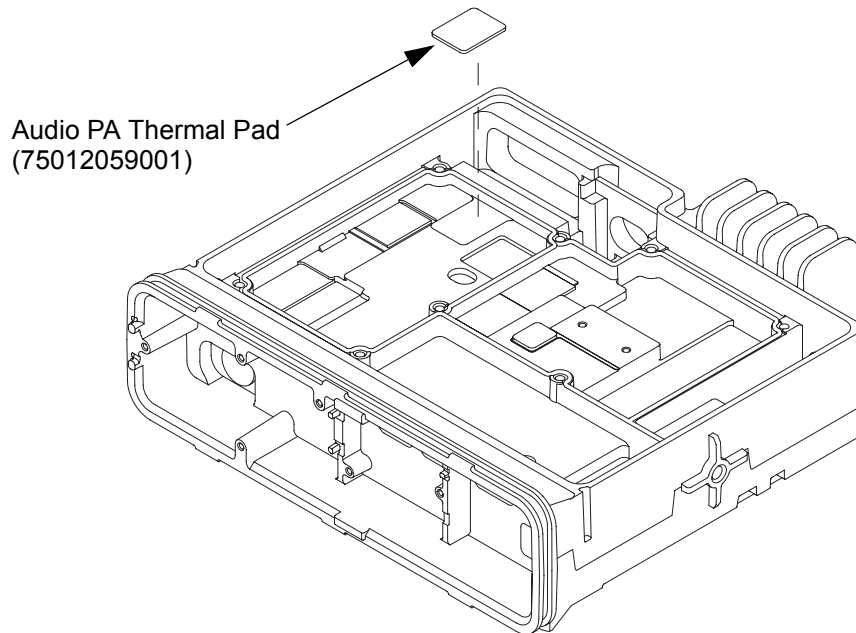

Figure 5-54 Replacing Audio PA Thermal Pad

Final Driver Thermal Pad Replacement

1. Use a plastic flat-edge tool to lift each pad from the transceiver board. Discard the old pad.
2. Use a soft cloth to remove any remaining residue. Alcohol can also be used, if necessary.
3. Once the surface is clean and dry, remove the new pad from the shipping liner, and place the pad on to the chassis as shown in Figure 5-55.

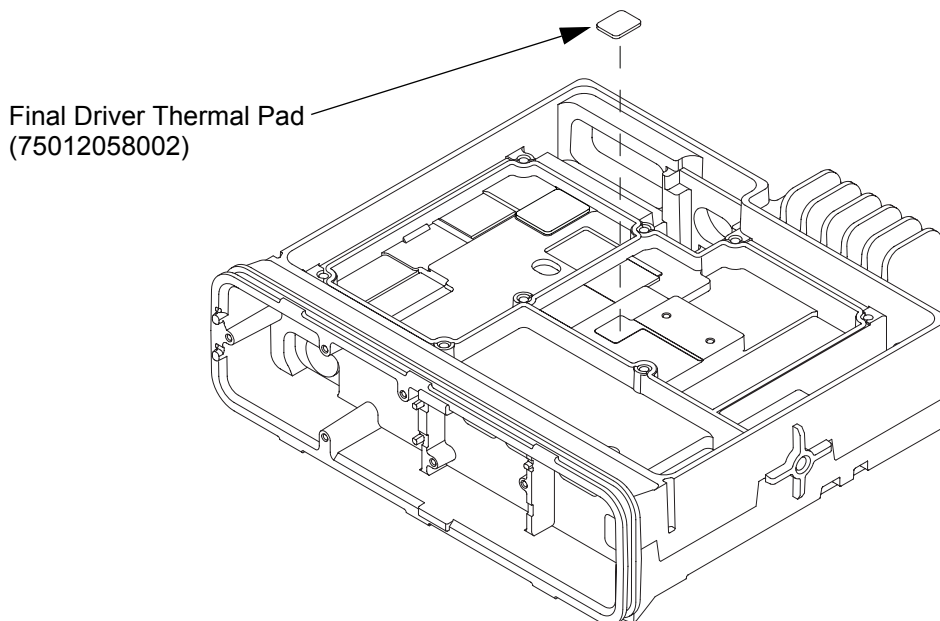

Figure 5-55 Replacing Final Driver Thermal Pad

5.7.5 Transceiver Board Reassembly

1. Apply thermal grease to the PA area. Refer to Figure 5-56.

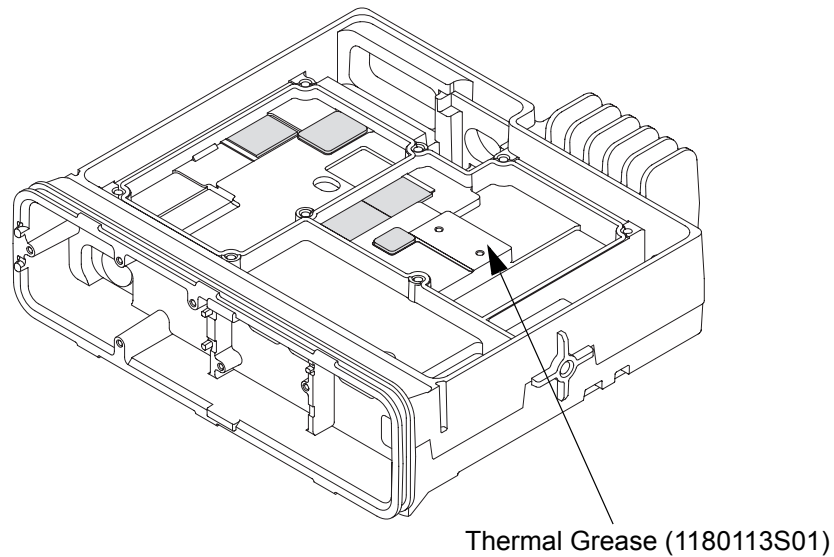

Figure 5-56 Applying Thermal Grease

2. Insert the transceiver board into the chassis by tilting the transceiver board (approximately 45 degrees) and sliding it into place, taking care to line up the RF and DC connectors with the openings in the back of the chassis.

Push the board down to fully seat it to the radio chassis and ensure that the transceiver board alignment slots are positioned in line with the chassis alignment bosses.

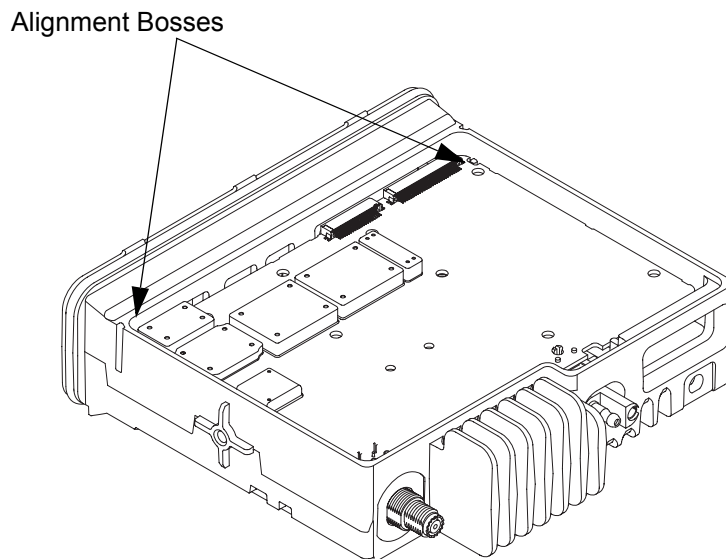



Figure 5-57 Placing the Transceiver Board in the Chassis

	<p>Do not leave the transceiver board in the chassis for extended periods of time without the DC retention clip and RF lock washer and nut assembled, or damage to the board connectors may occur.</p>
<p>Caution</p>	

3. Insert the DC retention clip and fully seat it. Refer to Figure 5-58.

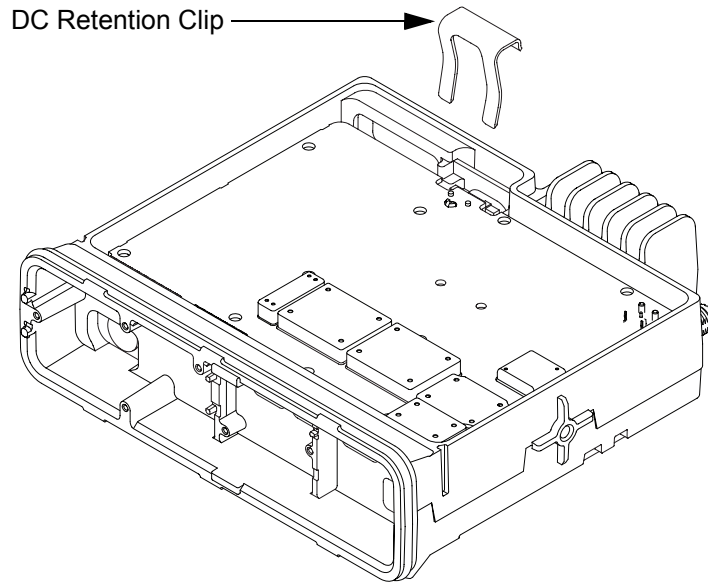

Figure 5-58 Inserting DC Retention Clip

- Using a $\frac{9}{16}$ " deep socket driver install the lock washer and nut to an initial torque of 0.9 N-m (8 lbs-in). Refer to Figure 5-59.

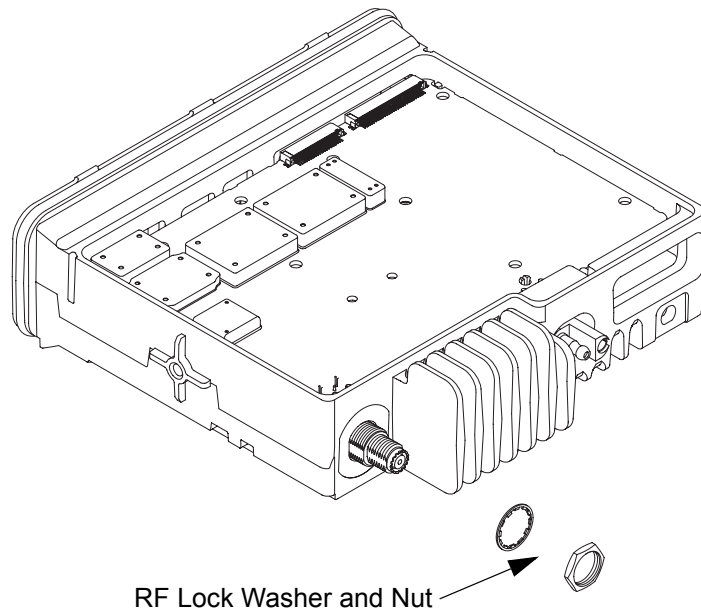

Figure 5-59 Inserting RF Lock Washer and Nut

- Using a T10 TORX™ driver insert four main shield thread forming screws (M3) at locations 3, 4, 5 and 6 to compress the PCB. Tighten the screws to 1.0 N-m (9 lbs-in).

NOTE: This step is required; otherwise, damage could result to the final transmitter PA device.

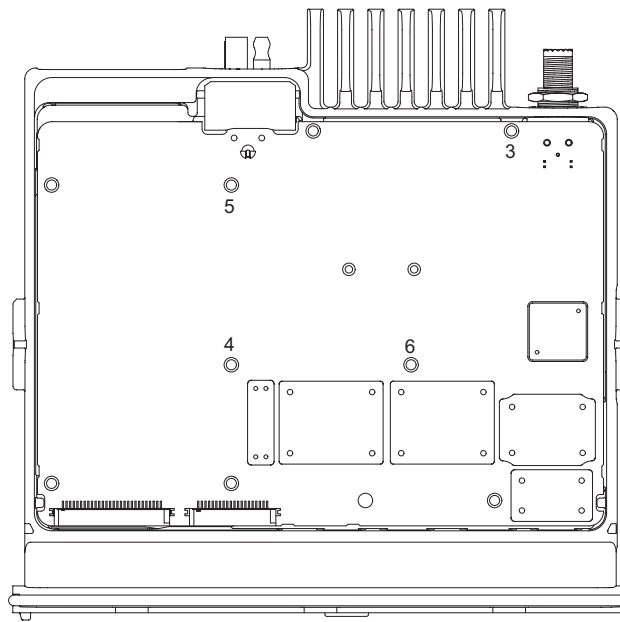

Figure 5-60 Screw Sequence to Compress PCB

6. While the board is pressed down, align the PA holes on PCB to mounting holes on chassis and insert two (M2.5) machine screws with washers (see Figure 5-61 for PA Screw sequence). Using a T8 TORX™ tighten the screws to 0.45 N-m (4 lbs-in).

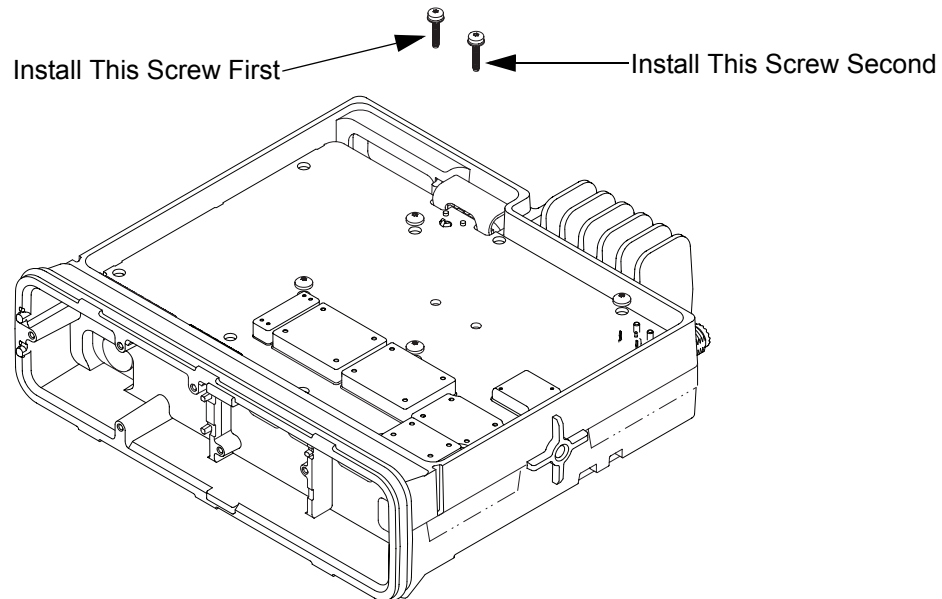

Figure 5-61 Installing PA Screws

7. Using a T10 TORX™ driver remove the screws from locations 3, 4, 5 and 6.
8. Insert the accessory connector into the radio assembly and press into place until the connector is flushed with the chassis. Refer to Figure 5-62.

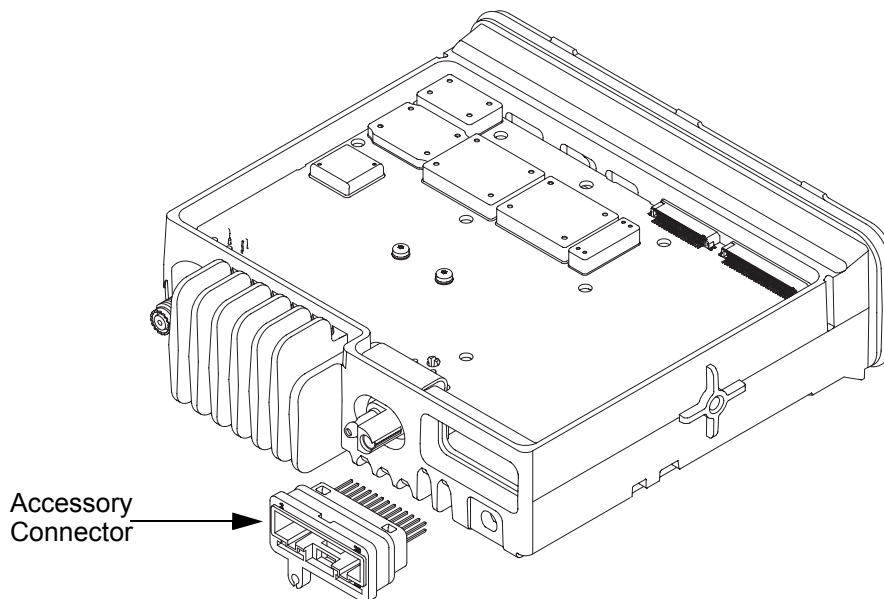

Figure 5-62 Inserting Accessory Connector

9. Place the main shield on the transceiver board and lock in place the accessory connector by aligning the main shield locking tabs to the pockets of the accessory connector.
10. Insert nine main shield thread forming screws (M3) through the shield and one thread forming screw (M3) through the board.
11. Using a T10 TORX™ driver follow the sequence marked on the shield and tighten the screws to 1.47 N-m (13 lbs-in). Refer to Figure 5-64.

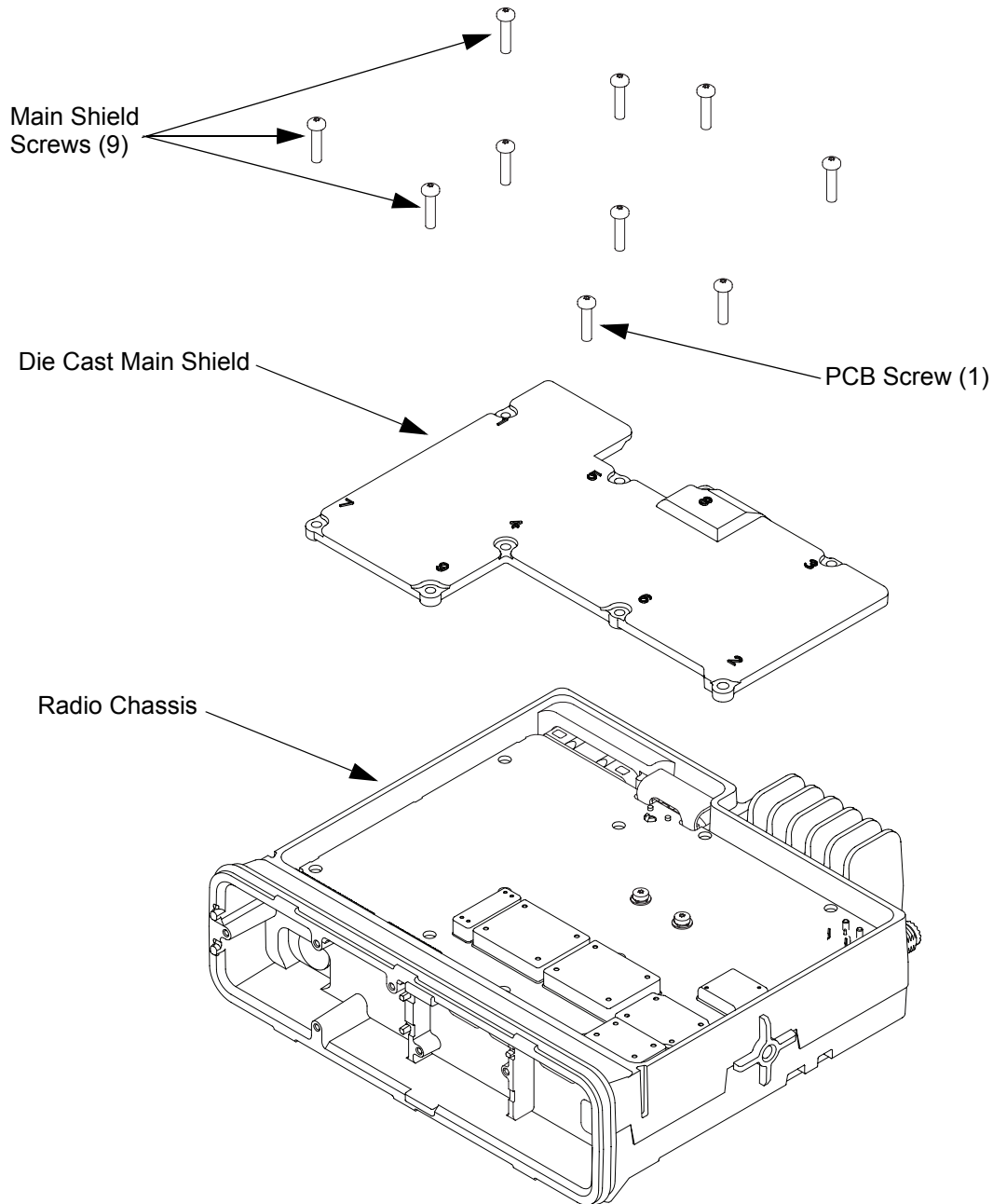

Figure 5-63 Assembling Die Cast Main Shield onto Chassis

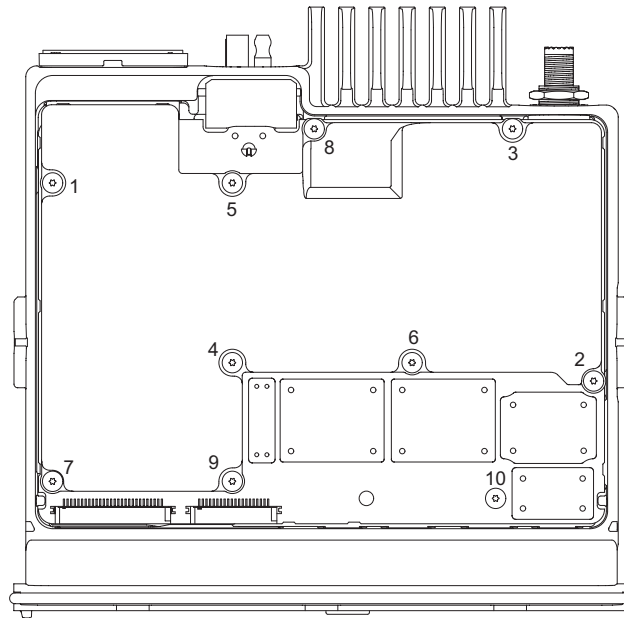

Figure 5-64 Screw Sequence to Tighten Die Cast Main Shield

12. Use a 9/16" deep socket driver to further tighten the nut to a final torque of 2.15 N-m (19 lbs-in).

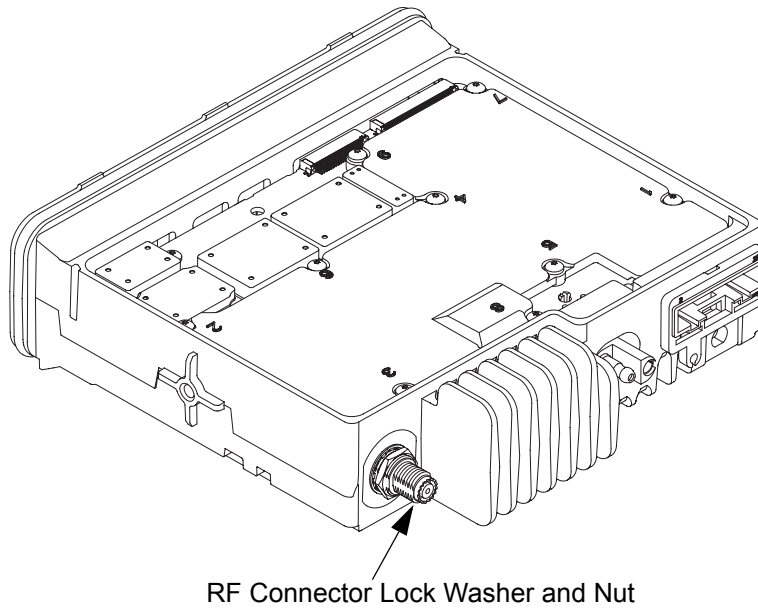

Figure 5-65 RF Connector Nut Final Torque

13. Install the acoustic plug. An arrow is molded into the part to indicate the start side.

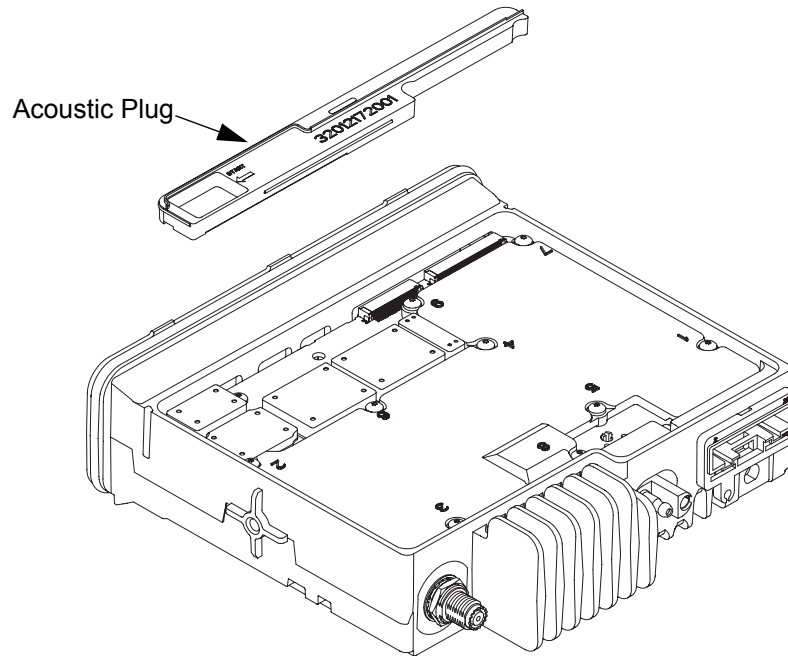

Figure 5-66 Acoustic Plug Installation

14. Thoroughly inspect the cover assembly with seal attached. Ensure the seal is fully seated on the cover and the locking tabs engaged at all seven locations.

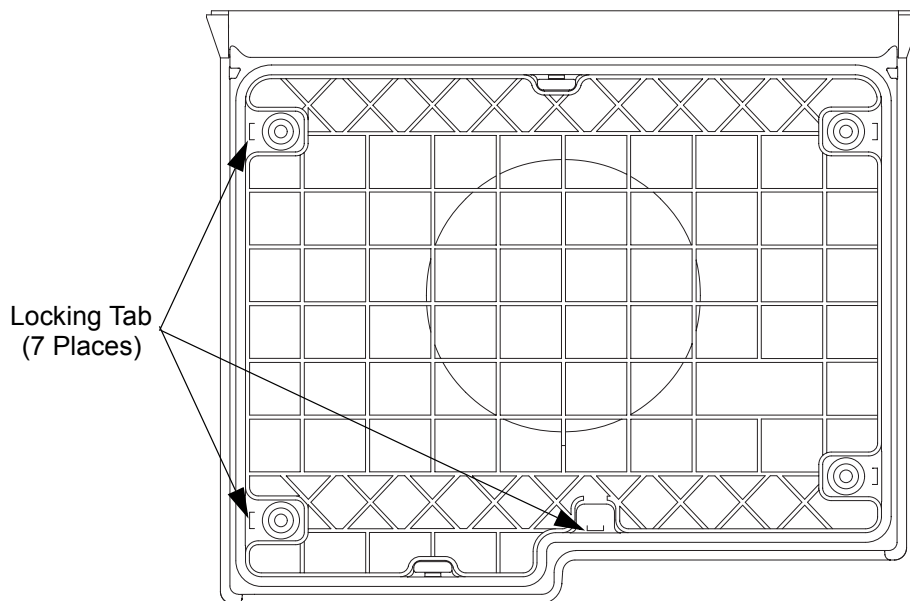

Figure 5-67 Inspection of Cover Assembly with Seal

15. Gently spread both sides of the cover.
16. Align the top cover to the chassis and snap the cover in place uniformly. Ensure the alignment posts on the cover slide into the alignment slots on the chassis.

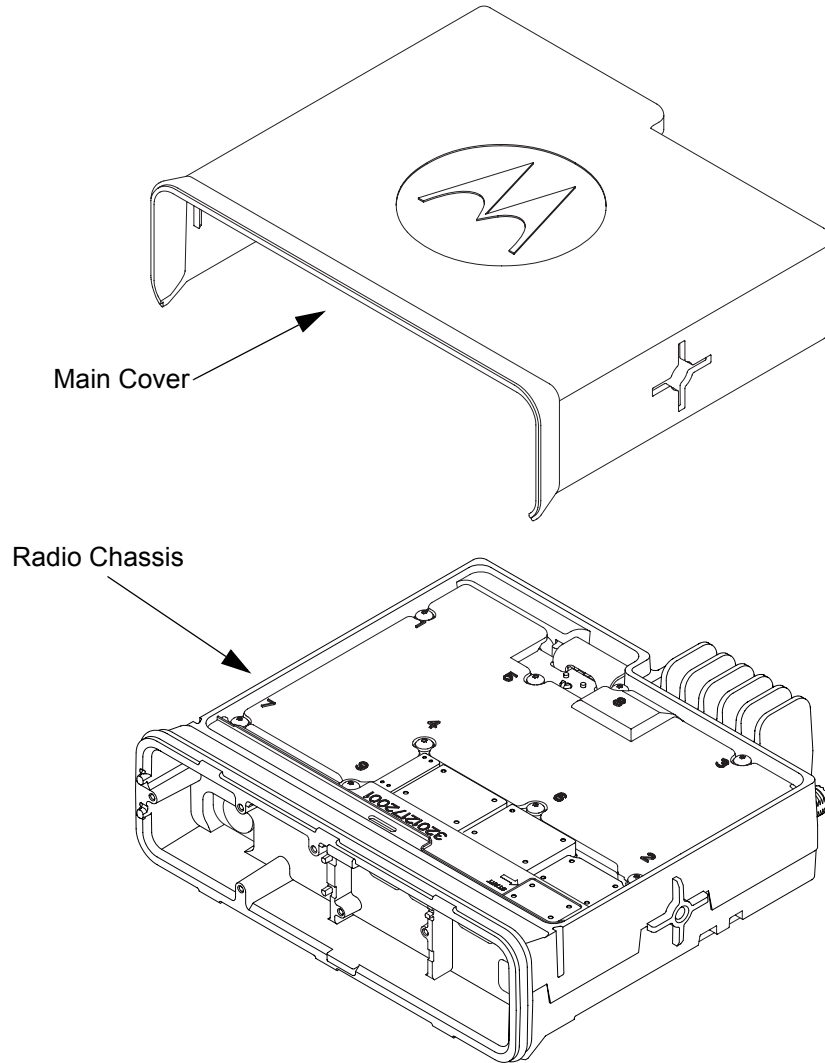

Figure 5-68 Assembling Cover onto Chassis

17. Assembly of the GPS cable.

NOTE: Skip steps a through d if the GPS cable was not serviced.

- a. If attached, remove the nut and washer from the GPS antenna connector.
- b. Insert the GPS cable assembly through the opening in the chassis. Orient the MCX connector as shown in Figure 5-69.
- c. Pull the GPS cable strain relief until it is fully installed. See Figure 5-70.
- d. Assemble the lock washer and the nut to the GPS antenna connector. Using a 5/16" or 8 mm socket driver, tighten the nut to 1.7 N-m (15 lbs-in). See Figure 5-70.

NOTE: Do not pull directly on cable wire.

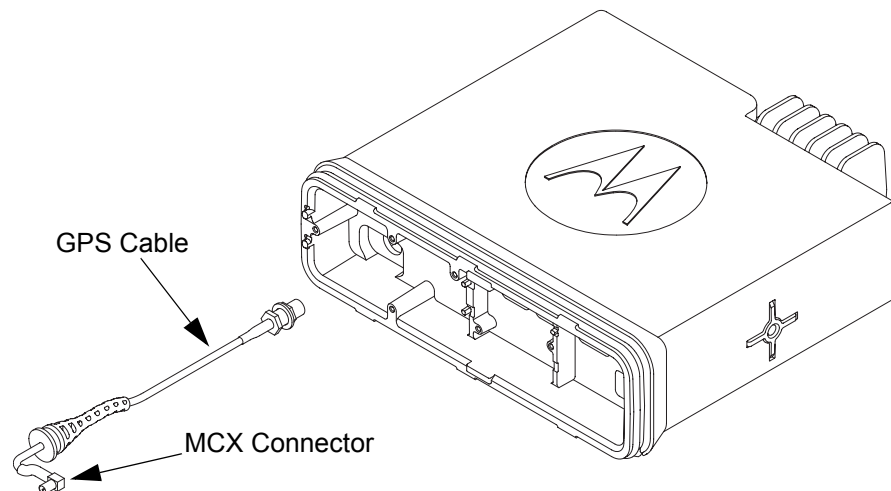

Figure 5-69 GPS Cable Installation

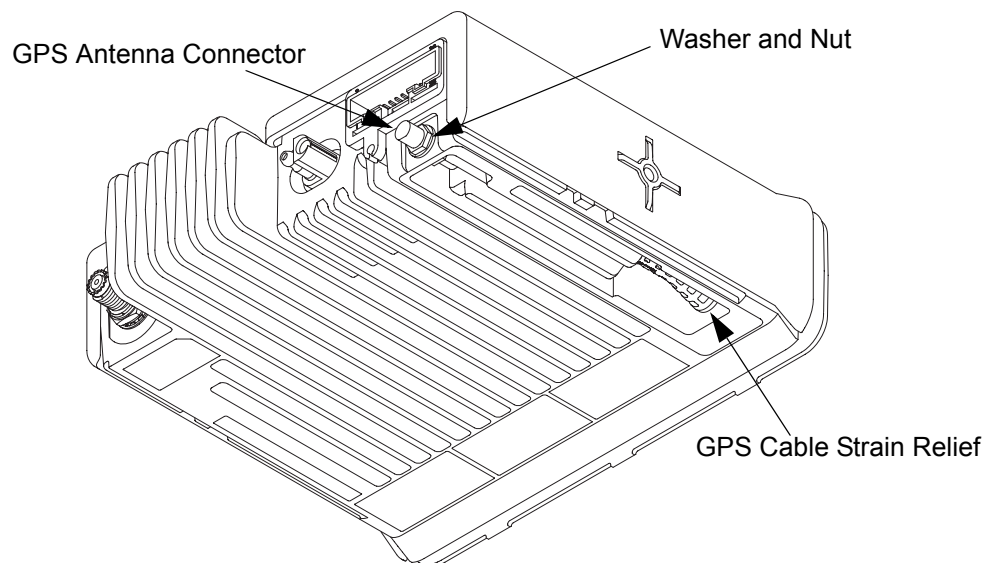

Figure 5-70 GPS Cable Installation

- e. Connect the GPS cable MCX connector to the expansion board.
- f. Connect the flex cable from the expansion board to the main board connector.

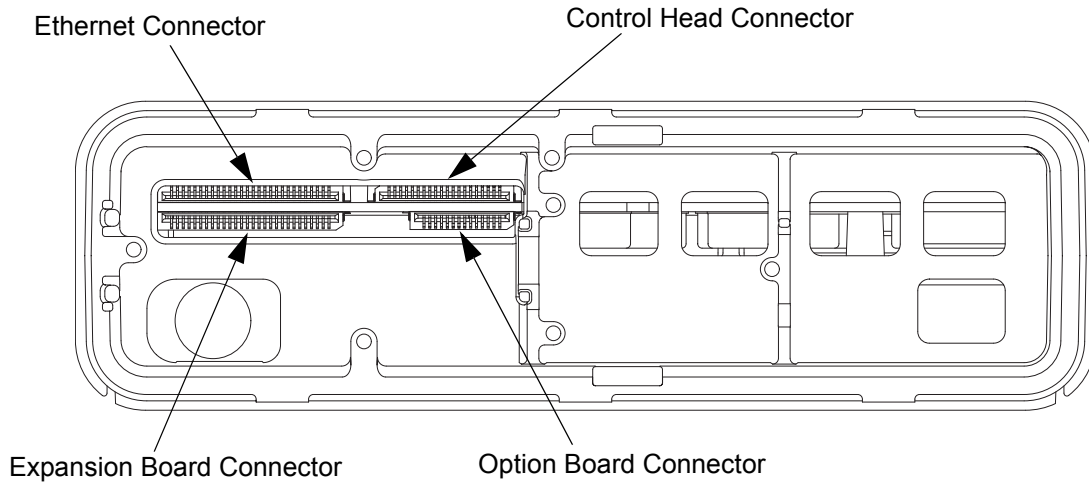

Figure 5-71 Flex Connection Connectors

- g. Using a T6 TORX™ driver, tighten the three screws to 0.28 N-m (2.5 lbs-in) to secure the expansion board to the chassis.

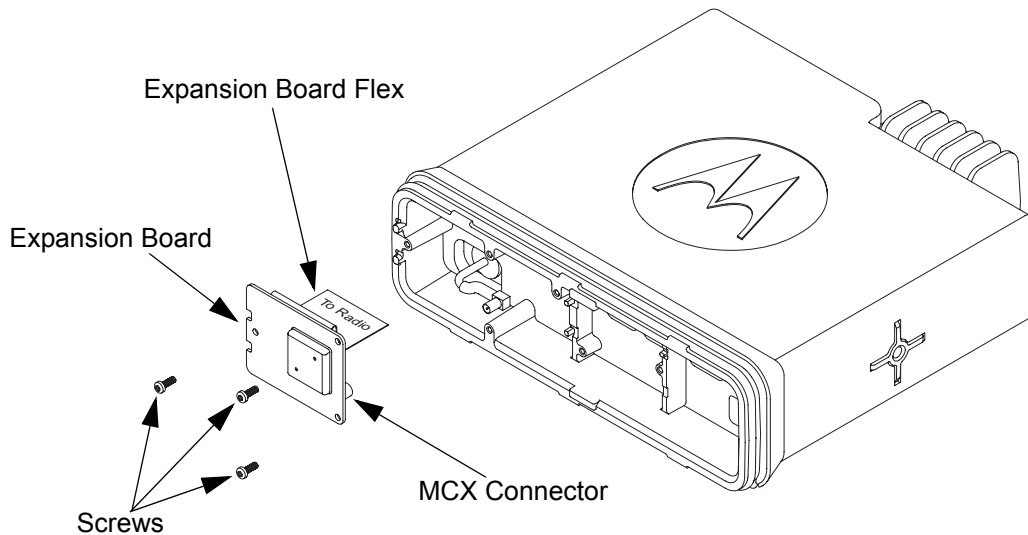

Figure 5-72 Expansion Board Assembly

NOTE: Skip steps h through j if the GPS nameplate was not serviced.

- h. Clean chassis nameplate surface with alcohol prior to applying the GPS nameplate.
- i. Peel off the paper liner to the GPS nameplate. Place the long side of the GPS nameplate against the long side of the recessed area on the chassis.

NOTE: If the GPS nameplate is removed it will need to be replaced.

- j. Rotate the nameplate to the recessed surface and apply pressure.

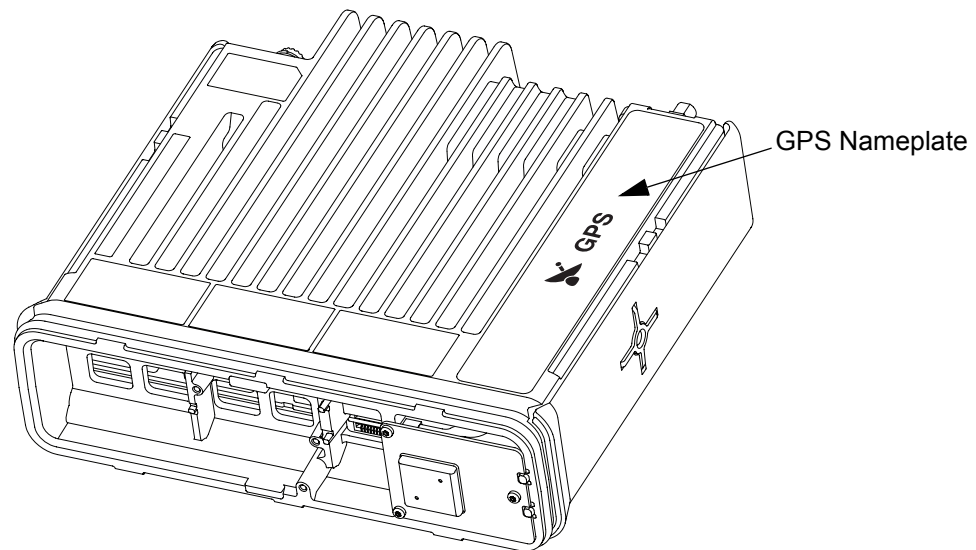

Figure 5-73 GPS Nameplate Assembly

NOTE: Skip step k if the GPS cable was not serviced.

- k. Snap the GPS dust cap (if not already installed) to the accessory connector retainer and place the GPS dust cap over the GPS antenna connector.

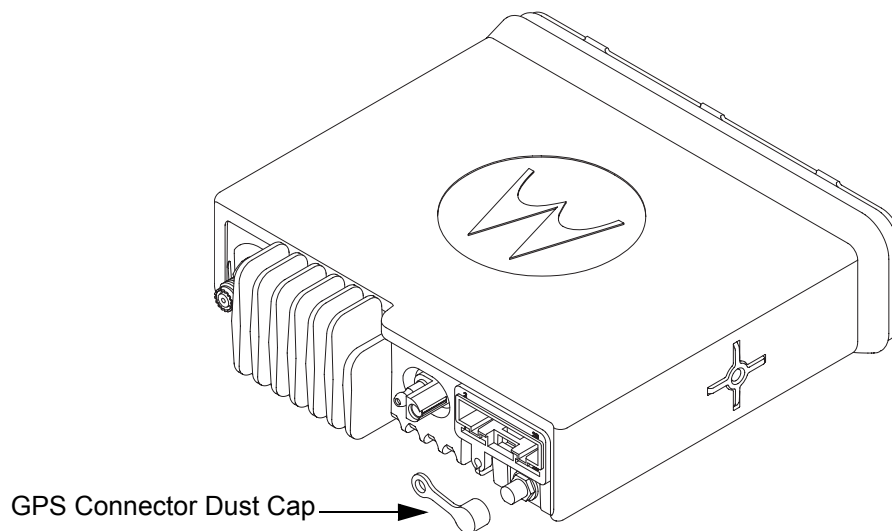

Figure 5-74 GPS Antenna Connector Assembly

18. Orient the option board flex so that contacts face option board. Secure connector latch to option board as referenced in Figure 5-75. Note white line on flex should be aligned with connector latch.

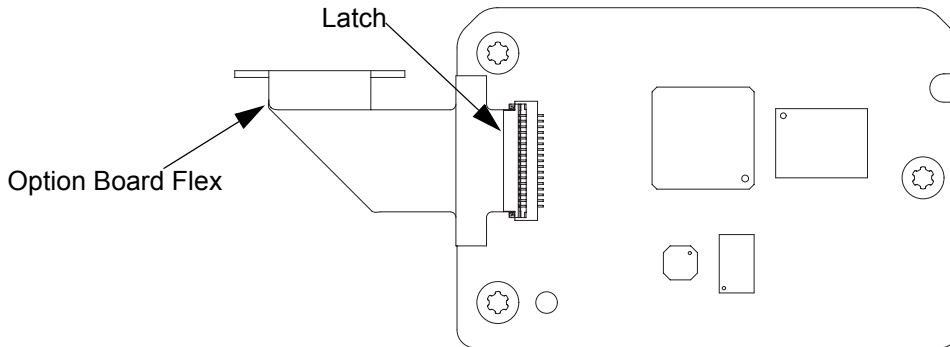

Figure 5-75 Orientation of Option Board Flex to Option Board

19. Maintaining the bend orientation, connect the flex cable from the option board to the main board connector.

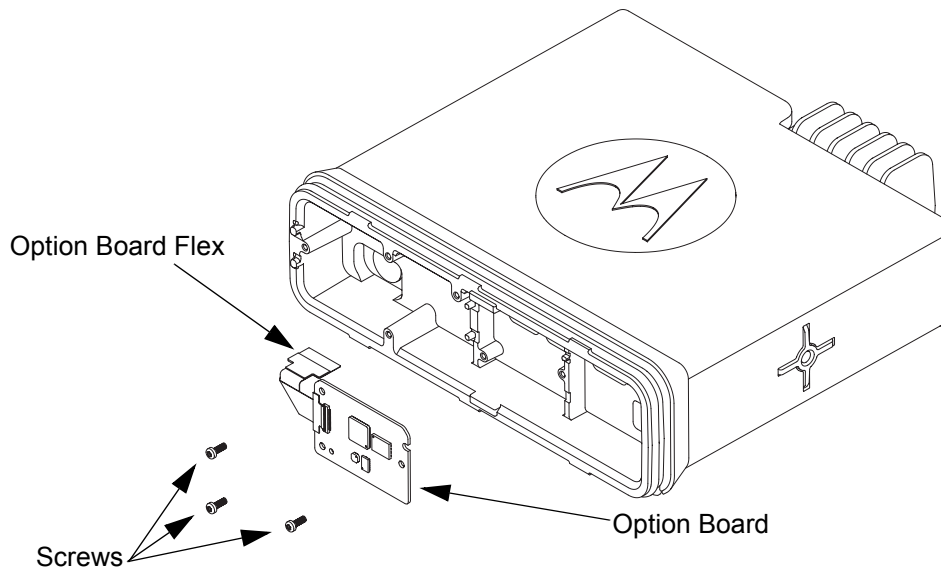

Figure 5-76 Assemble Option Board to Radio Chassis (Image May Not Match Exact Product)

- Align option board to mounting holes ensuring that the flex tabs are against the chassis alignment posts.

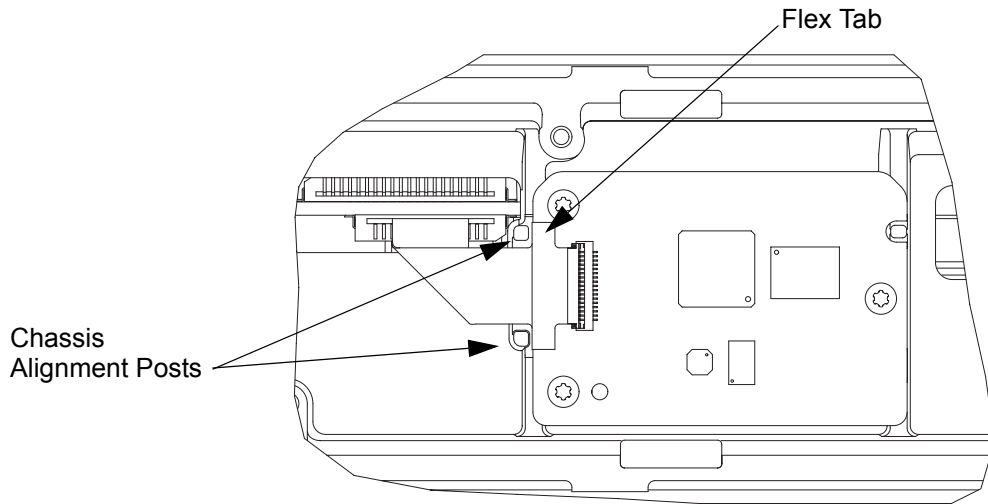

Figure 5-77 Align Option Board to Mounting Holes

- Using a T6 TORX™ driver, tighten the three screws to 0.28 N-m (2.5 lbs-in) to secure the option board to the chassis.

NOTE: Regulatory Requirements

All MOTOTRBO radios are designed and engineered to meet all regulatory requirements for the country or region of sale. Any option board designed for the MOTOTRBO Option Board ADK must not compromise the regulatory compliance of the MOTOTRBO radio.

The 3rd party developer is responsible for providing all information, upon request by a regulatory authority, in regards to any materials or substances used in the manufacture of an option board as it pertains to its end-of-life.

Please review the terms of the MOTOTRBO License Agreement for more information on the Licensed Developer or Application Partner responsibilities for regulatory compliance.

5.7.6 Assemble Control Head to Radio Assembly

1. Assemble the control head O-ring seal on the radio as shown in Figure 5-78.

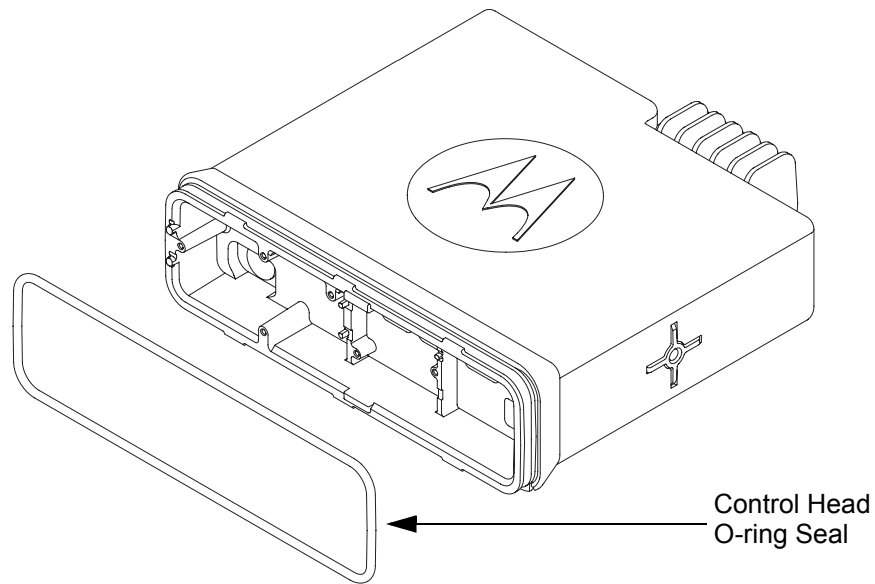

Figure 5-78 Assemble O-ring to Chassis (Image May Not Match Exact Product)

2. Verify that the flex cable is fully seated in the connector on the control head assembly.

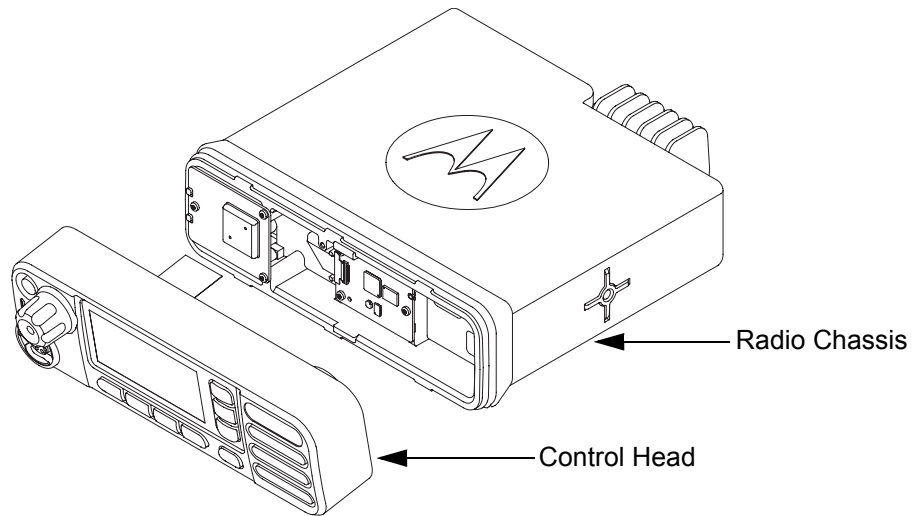

Figure 5-79 Assemble Control Head to Chassis

3. Assemble flex cable to the flex connector in the radio assembly, making sure it is fully seated.

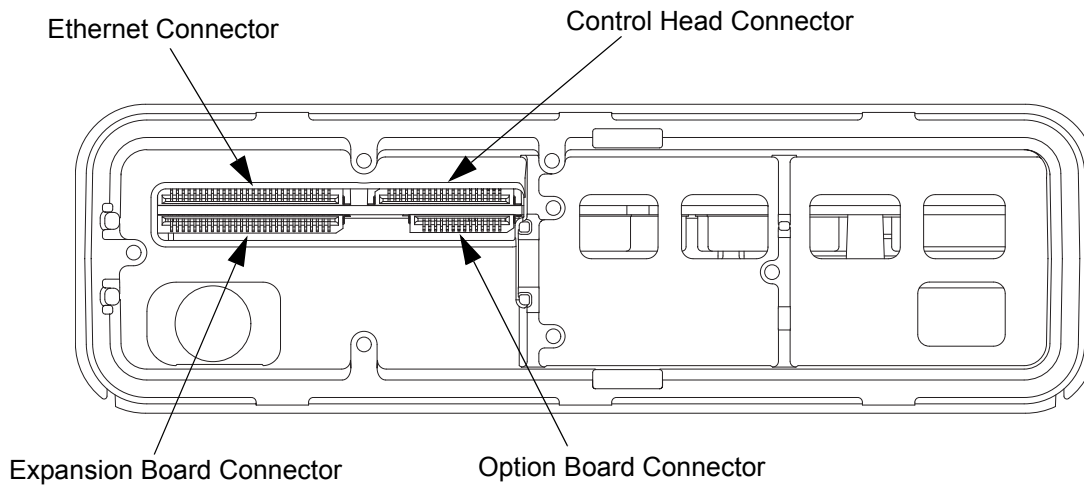

Figure 5-80 Flex Connection Connectors

4. Assemble the control head to the radio chassis by aligning one side of the control head assembly tabs to one side of the radio chassis tabs and then rotate the control head assembly until the other side engages.
5. Verify that the control head seal is not pinched and not visible. If a pinch is found, disassemble the control head, reseal the O-ring and reassemble the control head.

5.8 Exploded Mechanical Views and Parts Lists

5.8.1 Radio Assembly Exploded View and Parts List

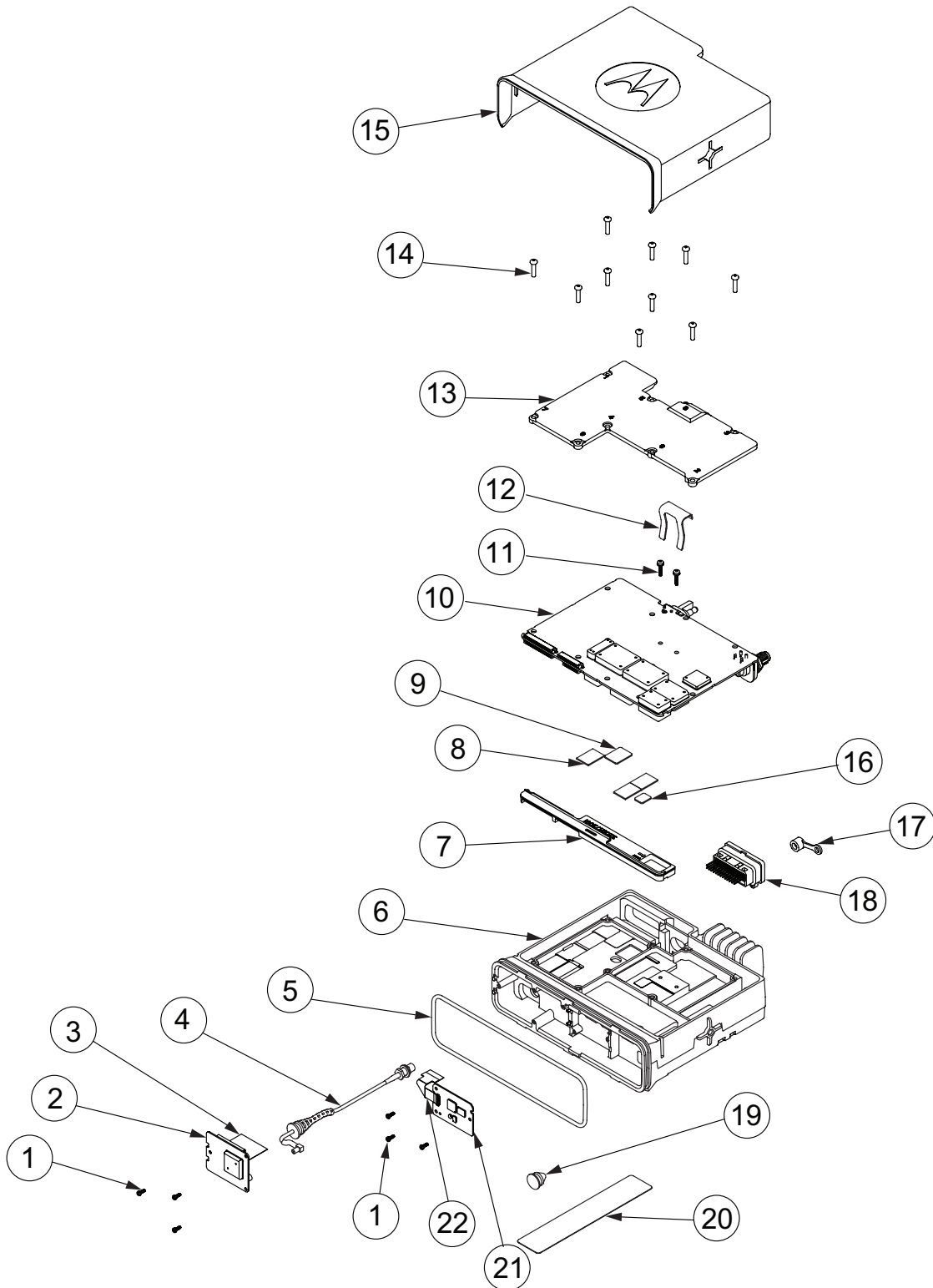

Figure 5-81 Radio Assembly Exploded View

Table 5-3 Radio Exploded View Parts List

Item No.	Description	Part Number
1	Screw - M2x0.4x6mm	0310909E03
2	Bluetooth/GPS Expansion Board	PMLN6042_S*
3	Flex, Expansion Board	30012047001
4	GPS Cable Assembly	30012044001
5	O-Ring, Control Head	3216200H01
6	Chassis, Die Cast	27009303001
7	Acoustic Plug	32012172001
8	Thermal Pad, Regulator (QTY:3)	75012018001
9	Thermal Pad, Audio PA	75012059001
10	PCB, Transceiver	See Section 1.5 to 1.8 to identify proper board.
11	Screw - M2.5x0.45x12mm with Washer	03012037001
12	Clip, DC Retention	42009281001
13	Main Shield, Die Cast	26009377001
14	Screw - M3x0.5x13mm	0310943J12
15	Main Cover and Gasket Assembly	15012083001
16	Thermal Pad, Final Driver	75012058002
17	GPS Dust Cap	3216338H01
18	Accessory Connector	42009282001
19	GPS Plug (not required)	32009445001
20	GPS Nameplate	54012193001
21	Generic Option Board	PMLN5718_S**
22	Flex, Option Board	84012231001

* Includes: Item No. 1 (Screw - M2x0.4x6mm)
Item No. 2 (Bluetooth/GPS Expansion Board)
Item No. 3 (Flex, Expansion Board)
Item No. 4 (GPS Cable Assembly)
Item No. 17 (GPS Dust Cap)
Item No. 20 (GPS Nameplate)

** Includes: Item No. 1 (Screw - M2x0.4x6mm)
Item No. 21 (Generic Option Board)
Item No. 22 (Flex, Option Board)

5.8.2 Control Head Exploded Views and Parts Lists

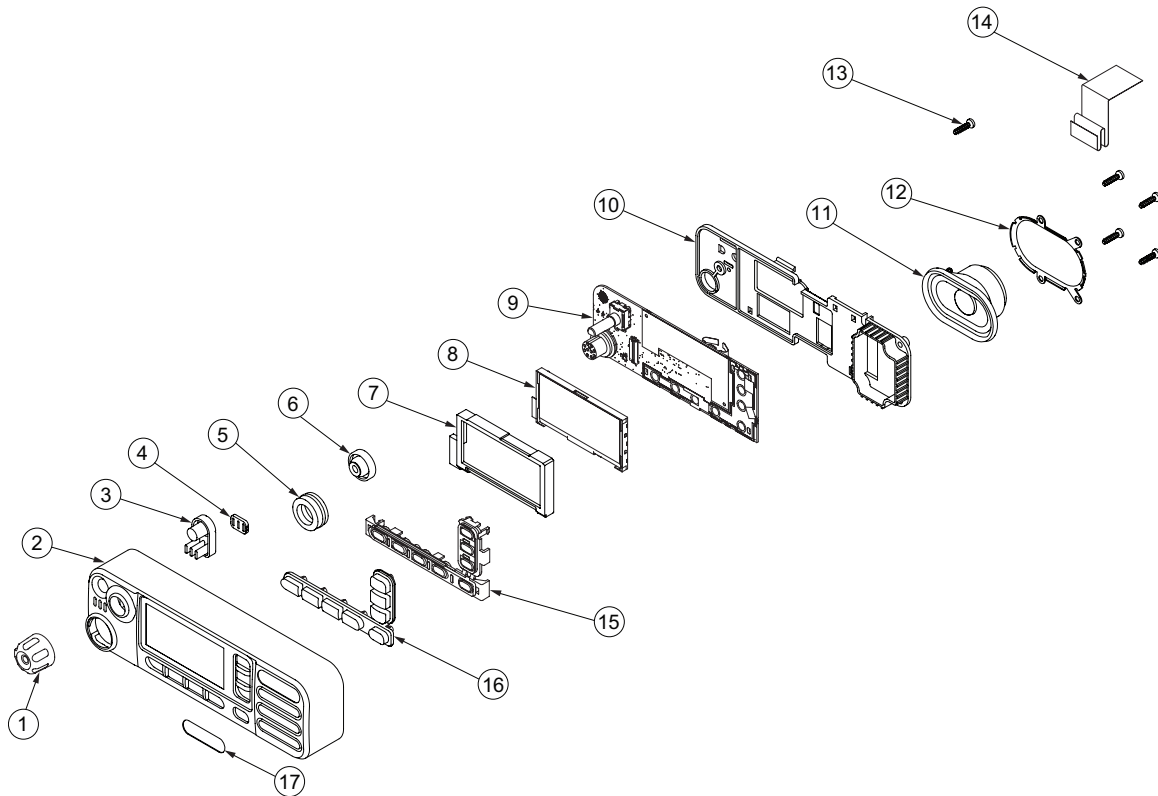

Figure 5-82 Color Display Control Head Exploded View

Table 5-4 Color Display Control Head (PMLN5678_) Exploded View Parts List

Item no	Description	Part No
1	Volume/Channel Knob Assembly	36012018001
2	Housing Assembly	0104045J47
3	Power Button	38012007001
4	Light Barrier, Power Button	07012020001
5	Mic Jack Seal	3264133H01
6	Volume Encoder Seal	32012140001
7	Color Display Pad Gasket	32012094001
8	Color Display	72012017001
9	PCB Assembly	0104045J49
10	PCB Retainer	42012024001
11	Speaker	5015134H02
12	Speaker Retainer	42012023001
13	Screw - K30x1.2x12mm	03012038001
14	Control Head Flex Cable	30012045001
15	Keypad Frame	42012026001
16	Keypad	75012061001
17	Nameplate Front Label for XPR 5550	33012017001

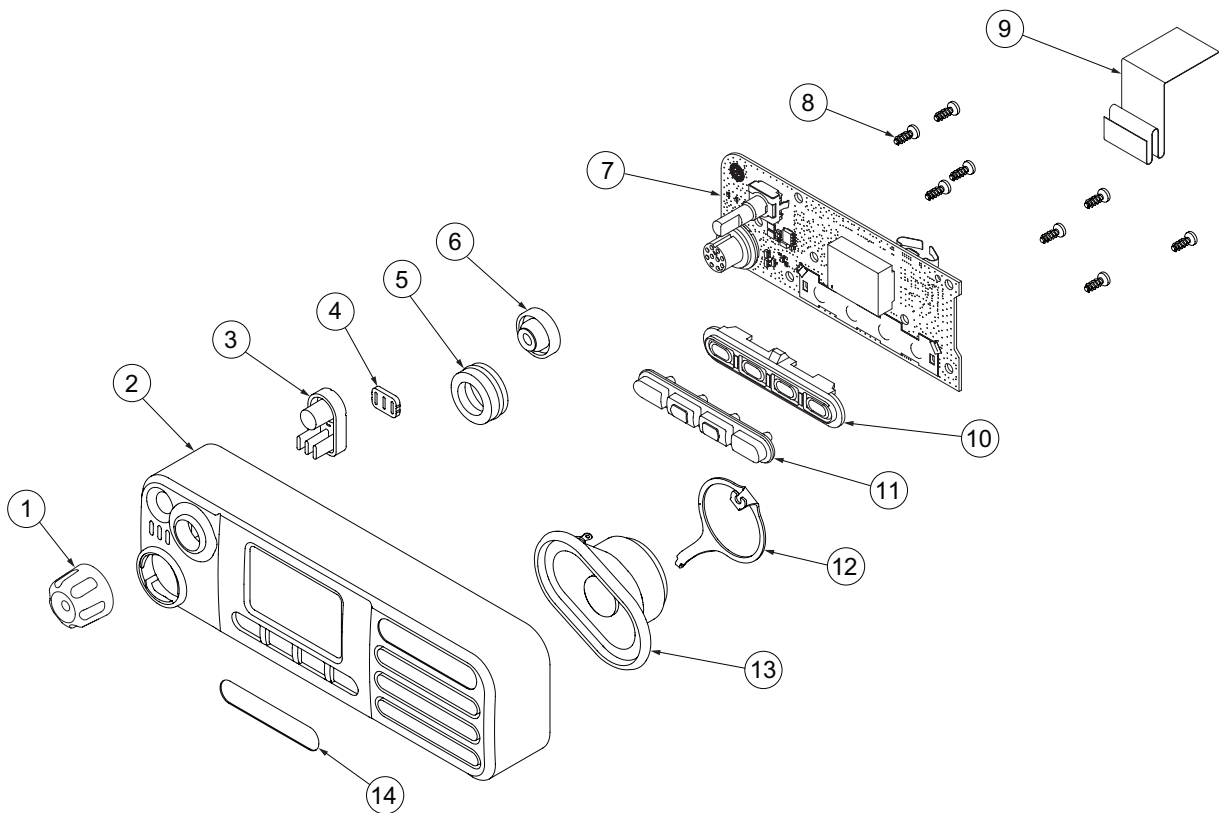

Figure 5-83 Numeric Display Control Head Exploded View

Table 5-5 Numeric Display Control Head (PMLN5677_) Exploded View Parts List

Item no	Description	Part No
1	Volume/Channel Knob Assembly	36012018001
2	Housing Assembly	0104045J48
3	Power Button	38012007001
4	Light Barrier, Power Button	07012020001
5	Mic Jack Seal	3264133H01
6	Volume Encoder Seal	32012140001
7	PCB Assembly	0104045J50
8	Screw - K30x1.34x8mm	0371370L01
9	Control Head Flex Cable	30012045001
10	Keypad Frame	42012025001
11	Keypad	75012060001
12	Speaker Retainer	42012030001
13	Speaker	5015134H02
14	Nameplate Front Label for XPR5350	33012017008

5.9 Torque Chart

Table 5-6 lists the various nuts and screws by part number and description, followed by the torque values in different units of measure. Torque all screws to the recommended value when assembling the radio.

Table 5-6 Torque Specifications for Nuts and Screws

Part Number	Description	Driver/Socket	Torque		
			N-m	lbs-in	kg-cm
30012044001	Nut, GPS Antenna Connector	5/16" or 8 mm socket driver	1.7	15	17.3
02012015001	Nut, RF Connector	9/16" deep socket driver	2.15	19	21.9
03012038001	Screw, K30x1.2x12mm, Pan Head	T10 Torx™	0.88	7.8	9.0
0371370L01	Screw, K30x1.34x8mm, Pan Head	T10 Torx™	0.88	7.8	9.0
0310909E03	Screw, M2x0.4x6mm, Pan Head	T6 Torx™	0.28	2.5	2.9
03012037001	Screw, M2.5x0.45x12mm, Pan Head	T8 Torx™	0.45	4	4.6
0310943J12	Screw, M3x0.5x13mm, Pan Head	T10 Torx™	1.5	13	15

Chapter 6 Basic Troubleshooting

6.1 Introduction

This chapter contains error codes and board replacement procedures. This section can help you isolate a problem to the board level. If the radio does not pass all the performance checks in Chapter 3 or exhibits an error code listed below, then the circuit board should be replaced. Please send the radio to a Motorola Service Center listed in Appendix B.

NOTE: To access the various connector pins, use the housing eliminator/test fixture along with the diagrams found in this section of the manual. (See Section, "Service Aids" on page 2-2, for the appropriate Motorola service aids and tools part numbers.)

6.1.1 High Power RF Precaution



Caution

The radio might transmit while the technician believes the radio is in receive mode under the following conditions: radio failure, digital affiliation, a defective PTT button, or other unintentional activations.

To avoid possible equipment damage, when performing both transmit and receive tests, a suitable attenuator rated at 100 W or more should always be used with test equipment connected to the RF connector. The only exception to this is when the equipment's input power rating is higher than the maximum output power of the radio.

6.2 Replacement Service Kit Procedures

Once a problem has been isolated to a specific board, install the appropriate service kit (see Model Charts in section 1.5 on page 1-5 through section 1.8 on page 1-8), which is orderable from Motorola Radio Products and Solutions Organization at 1-800-422-4210.

Refer to <http://www.motorola.com/businessonline> for further information.

If a board is replaced, it does not necessarily need to be retuned if it has been factory tuned. It should however be checked for performance before being placed into service. Of particular concern is the Bias DAC, which will need to be set for the appropriate final device bias current prior to keying up the radio. If the bias is not properly set it may be possible to cause damage to the transmitter.



Caution

The Tuner Tool only allows the serial number of a blank board to be entered once. Be very attentive during this procedure.

6.3 Power-Up Error Codes

When the radio is turned on (power-up), the radio performs cursory tests to determine if its basic electronics and software are in working order. Problems detected during these tests are presented as error codes on the radio's display. The presence of an error should prompt the user that a problem exists and that a service technician should be contacted.

Self-test errors are classified as either fatal or non-fatal. Fatal errors inhibit user operation; non-fatal errors do not. Use the following tables to aid in understanding particular power-up error code displays.

Table 6-1 Power-Up Error Codes

Error Code	Description	Error Type	Corrective Action
ERROR 01/02	FLASH ROM Codeplug Checksum	NON-FATAL	Reprogram the codeplug.
ERROR 01/22	Tuning Codeplug Checksum	NON-FATAL	Reprogram the tuning partition.
FAIL 01/82	FLASH ROM Codeplug Checksum	FATAL	Reprogram the codeplug.
FAIL 01/90	General Hardware Error	FATAL	Turn the radio off, then on.
FAIL 01/92	Security Partition Checksum	FATAL	Reprogram the security partition.
FAIL 01/93	FlashPORT AUTHENT CODE Failure	FATAL	Contact the depot.
FAIL 01/A2	Tuning Codeplug Checksum	FATAL	Reprogram the tuning partition.

6.4 Operational Error Codes

During radio operation, the radio performs dynamic tests to determine if the radio is working properly. Problems detected during these tests are presented as error codes on the radio's display. The presence of an error code should prompt a user that a problem exists and that a service technician should be contacted. Use Table 6-2 to aid in understanding particular operational error codes.

Table 6-2 Operational Error Codes

Error Code	Description	Error Type	Corrective Action
FAIL 001	Synthesizer Out-of-Lock	NON-FATAL	Reprogram the codeplug. Send radio to the nearest Motorola Depot.
FAIL 002	Personality checksum or system block error	NON-FATAL	Reprogram the codeplug.

Chapter 7 Accessories

7.1 Introduction

Motorola provides the following approved accessories to improve the productivity of your digital mobile two-way radio.

For a list of Motorola-approved antennas, and other accessories, visit the following web site:
<http://www.motorolasolutions.com/governmentandenterprise>

7.1.1 Audio

Part No.	Description
HMN4098_	Telephone Style Handset
RMN5050_	Desktop Microphone
RMN5052_	Compact Microphone
RMN5053_	Heavy Duty Microphone with Enhanced Audio
RMN5054_	Visor Microphone with Enhanced Audio
RMN5127_	4-Way Navigation Keypad Microphone with Enhanced Audio

7.1.2 Speakers

Part No.	Description
RSN4002_	13 Watt External Speaker
RSN4003_	7.5 Watt External Speaker
RSN4004_	5 Watt External Speaker

7.1.3 Desktop Accessories

Part No.	Description
GLN7318_	Desktop Tray without Speaker
RSN4005_	Desktop Tray with Speaker
HPN4007_	Power Supply and Cable
GPN6145_	Switchmode Power Supply (1-25 Watt Models)(CE Marked)
GKN6266_	Radio Power Cable (for GPN6145)
NTN7373_R	3060665A04 US Line Cord
HKN9088_	Mobile Mini-U Antenna Adaptor, 8-foot Cable
PMLN5072_	Hardware Kit for Rear Accessory Connector

7.1.4 Mounting Kits

Part No.	Description
RLN6465_	In Dash (DIN) Mounting Kit
RLN6466_	Low Profile Trunnion Kit
RLN6467_	Standard Profile Trunnion Kit
RLN6468_	Key Lock Trunnion Kit

7.1.5 Cables

Part No.	Description
HKN4137_	Power Cable to Battery, 3m (10 ft.), 15 amp (1–25W)
HKN4191_	Power Cable to Battery, 3m (10 ft.), 20 amp (1–45W)
HKN4192_	Power Cable to Battery, 6m (20 ft.), 20 amp (1–45W)
HKN6184_	Mobile Front Programming Cable
PMKN4010_	Mobile & Repeater Rear Programming Cable
PMKN4016_	Mobile & Repeater Rear Accessory Programming and Test Cable
PMKN4018_	Mobile & Repeater Rear Accessory Connector Universal Cable
PMKN4033_	Cable, Mobile Mic Extension, 10 feet
PMKN4034_	Cable, Mobile Mic Extension, 20 feet
PMKN4070_	IMPRES Mobile MMP Non PC Adaptor
PMKN4072_	IMPRES Mobile MAP Non PC Adaptor
RKN4136_	Ignition Sense Cable

7.1.6 Antennas

Part No.	Description
HAD4006_	VHF, 136–144 MHz, 1/4 Wave, Through-hole Mount, Mini-U
HAD4007_	VHF, 146–150.8 MHz, 1/4 Wave, Through-hole Mount, Mini-U
HAD4008_	VHF, 150.8–162 MHz, 1/4 Wave, Through-hole Mount, Mini-U
HAD4009_	VHF, 162–174 MHz, 1/4 Wave, Through-hole Mount, Mini-U
HAD4022_	VHF, 132–174 MHz, 3.0 dB Gain, Through-hole Mount, Mini-U
HAE4002_	UHF, 403–430 MHz, 1/4 Wave, Through-hole Mount, Mini-U
HAE4003_	UHF, 450–470 MHz, 1/4 Wave, Through-hole Mount, Mini-U
HAE4010_	UHF, 406–420 MHz, 3.5 dB Gain, Through-hole Mount, Mini-U
HAE4011_	UHF, 450–470 MHz, 3.5 dB Gain, Through-hole Mount, Mini-U
HAE6022_	UHF, 403–527 MHz, 2.0 dB Gain, Through-hole Mount, Mini-U
RAE4004_RB	UHF, 445–470 MHz, 5.0 dB Gain, Through-hole Mount, Mini-U (with base)
RAD4214_	Combination GPS/VHF 136–144 MHz, 1/4 Wave, Through-hole Mount, Mini-U

Part No.	Description
RAD4215_	Combination GPS/VHF 146–150.8 MHz, 1/4 Wave, Through-hole Mount, Mini-U
RAD4216_	Combination GPS/VHF 150.8–162 MHz, 1/4 Wave, Through-hole Mount, Mini-U
RAD4217_	Combination GPS/VHF 162–174 MHz, 1/4 Wave, Through-hole Mount, Mini-U
RAD4218_	Combination GPS/VHF 146–172 MHz, 3.0 dB Gain, Through-hole Mount, Mini-U
PMAE4030_	Combination GPS/UHF 403–430 MHz, 1/4 Wave, Through-hole Mount, Mini-U
PMAE4031_	Combination GPS/UHF 450–470 MHz, 1/4 Wave, Through-hole Mount, Mini-U
PMAE4032_	Combination GPS/UHF 406–420 MHz, 3.5 dB Gain, Through-hole Mount, Mini-U
PMAE4033_	Combination GPS/UHF 450–470 MHz, 3.5 dB Gain, Through-hole Mount, Mini-U
PMAE4034_	Combination GPS/UHF 450–470 MHz, 5.0 dB Gain, Through-hole Mount, Mini-U
HAE6019_	Combination GPS/UHF 403–527 MHz, 2.0 dB Gain, Through-hole Mount, Mini-U
PMAN4000_	Fixed Mount GPS Active Antenna
PMAN4001_	Window Mount GPS Active Antenna
PMAN4002_	Magnetic Mount GPS Active Antenna
Replacement Antennas	
RAE4004_	UHF, 445–470 MHz, 5.0 dB Gain, Through-hole Mount, Mini-U (without base)
RAD4223_	Kit, Antenna VHF 162–174 MHz, 1/4 Wave
RAD4224_	Kit, Antenna VHF 150.8–162 MHz, 1/4 Wave
RAD4225_	Kit, Antenna VHF 146–150.8 MHz, 1/4 Wave
RAD4226_	Kit, Antenna VHF 136–144 MHz, 1/4 Wave
RAD4227_	Kit, Antenna VHF 146–172 MHz, 3.0 dB Gain
PMAE4039_	Kit, Antenna UHF 403–430 MHz, 1/4 Wave
PMAE4040_	Kit, Antenna UHF 406–420 MHz, 3.5 dB Gain
PMAE4041_	Kit, Antenna UHF 450–470 MHz, 1/4 Wave
PMAE4042_	Kit, Antenna UHF 450–470 MHz, 3.5 dB Gain
PMAE4043_	Kit, Antenna UHF 450–470 MHz, 5.0 dB Gain
HAE6029_	Kit, Antenna UHF 403–527 MHz, 2.0 dB Gain, Through-hole Mount
PMAN4004_	Kit, Combo GPS+RF, Base Only, Through-hole Mount, Mini-U

7.1.7 Bluetooth

Part No.	Description
NNTN8125_	Operations Critical Wireless Earpiece, 12" Cable
NNTN8126_	Operations Critical Wireless Earpiece, 9.5" Cable
NNTN8127_	Operations Critical Wireless Push to Talk POD
NTN2572_	Replacement Wireless Earpiece, 12" Cable
NTN2575_	Replacement Wireless Earpiece, 9.5" Cable
PMPN4009_	Micro USB Charger (US)
89409N	HK200 Bluetooth Headset

7.1.8 Miscellaneous Accessories

Part No.	Description
HLN9073_	Microphone Hang-up Clip (All Microphones)
HLN9414_	Universal Microphone Hang-up Clip (All Microphones)
HKN9557_	PL259/Mini-U Antenna Adaptor, 8-foot Cable
PMEN4027_	Chassis Eliminator Kit
PMLN6042_S	Bluetooth/GPS Expansion Board
PMLN5718_S	Generic Option Board
RLN5926_	Push Button PTT
RLN5929_	Emergency Footswitch
3075336B07	Compact Microphone Replacement Cable
3075336B10	Heavy Duty/Keypad Microphone Replacement Cable
6686119B01	Control Head Dismantling Tool
66012025001	Volume/Channel Knob Removal Tool

Appendix A Replacement Parts Ordering

A.1 Basic Ordering Information

Some replacement parts, spare parts, and/or product information can be ordered directly. While parts may be assigned with a Motorola part number, this does not guarantee that they are available from Motorola Radio Products and Solutions Organization (RPSO). Some parts may have become obsolete and no longer available in the market due to cancelations by the supplier. If no Motorola part number is assigned, the part is normally not available from Motorola, or is not a user-serviceable part. Part numbers appended with an asterisk are serviceable by Motorola Depot only.

A.2 Motorola Online

Motorola Online users can access our online catalog at

<http://www.motorola.com/businessonline>

To register for online access, please call 1-800-422-4210 (for U.S. and Canada Service Centers only). International customers can obtain assistance at <http://www.motorola.com/businessonline>

A.3 Mail Orders

Mail orders are only accepted by the US Federal Government Markets Division (USFGMD).

Motorola
7031 Columbia Gateway Drive
3rd Floor - Order Processing
Columbia, MD 21046
U.S.A.

A.4 Telephone Orders

Radio Products and Solutions Organization*
(United States and Canada)
7:00 AM to 7:00 PM (Central Standard Time)
Monday through Friday (Chicago, U.S.A.)
1-800-422-4210
1-847-538-8023 (United States and Canada)

U.S. Federal Government Markets Division (USFGMD)
1-877-873-4668
8:30 AM to 5:00 PM (Eastern Standard Time)

A.5 Fax Orders

Radio Products and Solutions Organization*
(United States and Canada)
1-800-622-6210
1-847-576-3023 (United States and Canada)

USFGMD
(Federal Government Orders)
1-800-526-8641 (For Parts and Equipment Purchase Orders)

A.6 Parts Identification

Radio Products and Solutions Organization*
(United States and Canada)
1-800-422-4210

A.7 Product Customer Service

Radio Products and Solutions Organization (United States and Canada)
1-800-927-2744

* The Radio Products and Solutions Organization (RPSO) was formerly known as the Radio Products Services Division (RPSD) and/or the Accessories and Aftermarket Division (AAD).

Appendix B Motorola Service Centers

B.1 Servicing Information

If a unit requires further complete testing, knowledge and/or details of component level troubleshooting or service than is customarily performed at the basic level, please send the radio to a Motorola Service Center as listed below.

B.2 Motorola Service Center

1220 Don Haskins Drive
Suite A
El Paso, TX 79936
Tel: 915-872-8200

B.3 Motorola Federal Technical Center

10105 Senate Drive
Lanham, MD 20706
Tel: 1-800-969-6680
Fax: 1-800-784-4133

B.4 Motorola Canadian Technical Logistics Center

Motorola Canada Ltd.
8133 Warden Avenue
Markham, Ontario, L6G 1B3
Tel: 1-800-543-3222
Fax: 1-888-331-9872 or 1-905-948-5970

Notes

Appendix C Limited Level 3 Servicing

C.1 Maintenance

For details on the following, please refer to Chapter 5 Disassembly/Reassembly Procedures – Section 5.2 on page 5-1 to Section 5.4 on page 5-4.

- Preventive maintenance (inspection and cleaning).
- Safe handling of CMOS and LDMOS devices.
- Repair procedures and techniques.

C.2 Component Location and Parts List

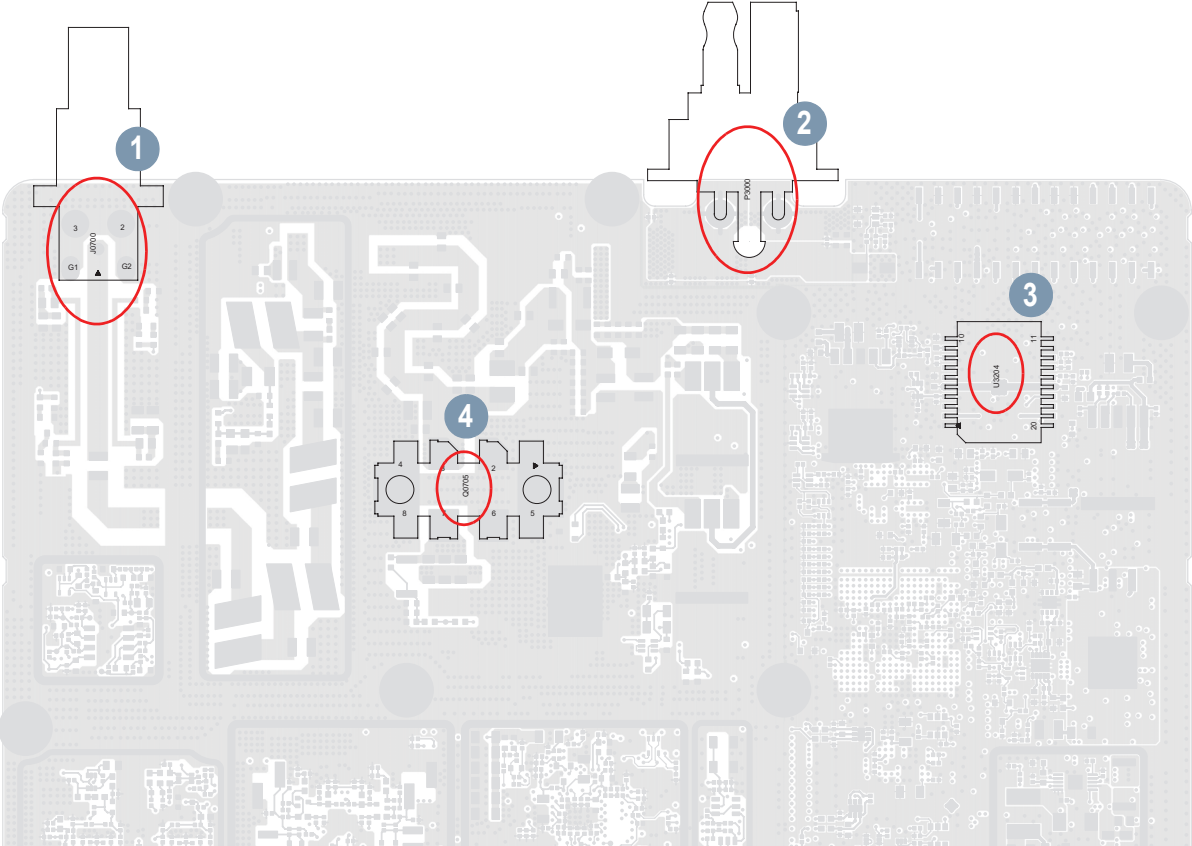

Figure C-1 PCB Top Side View

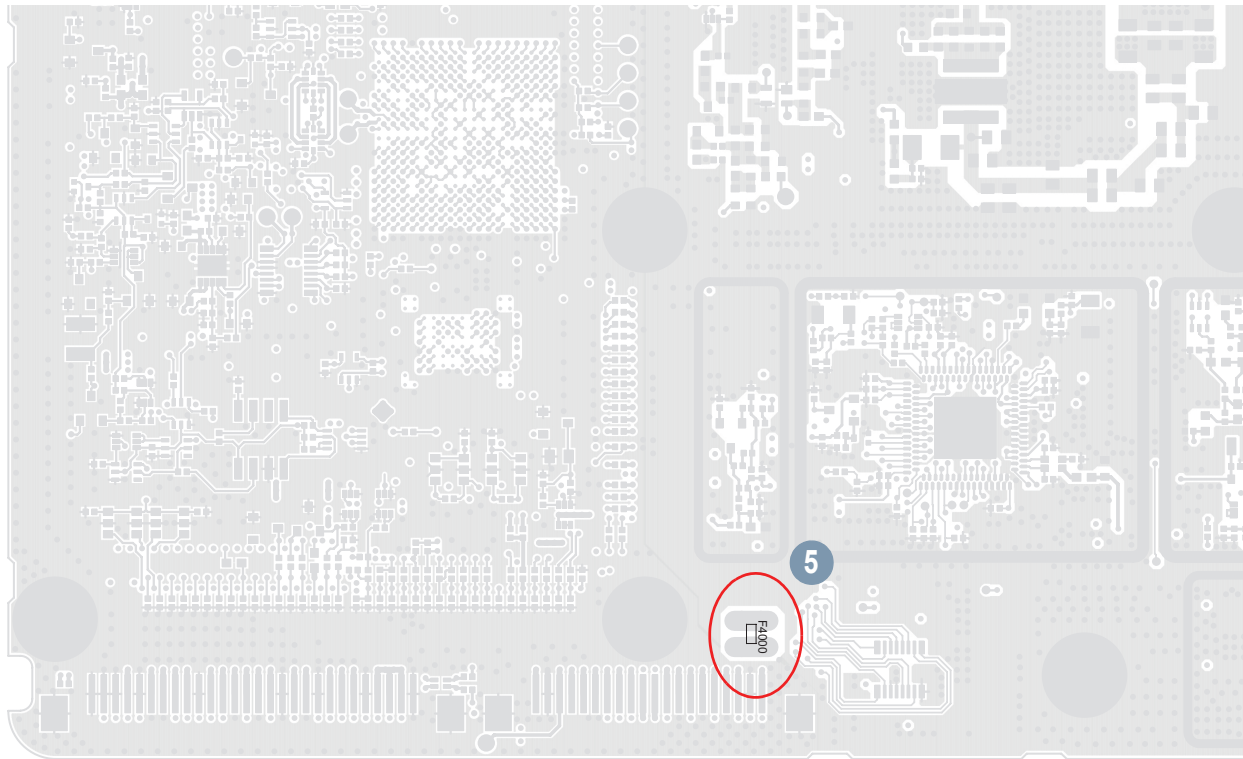

Figure C-2 PCB Bottom Side View

Table C-1. Component Parts List

No.	Circuit Ref.	Motorola Part Number	Description
1	J0700	09009348001	Mini-UHF Female RF Connector
2	P3000	09009344001	DC Power Connector
3	U3204	51009509001	IC Audio Amplifier 1 Per Package
4	Q0705	48012067002	RF MOS FET Power Transistor
5	F4000	6515076H01	Fast Blow 3A, 24V Fuse

Glossary

This glossary contains an alphabetical listing of terms and their definitions that are applicable to portable and mobile subscriber radio products. All terms do not necessarily apply to all radios, and some terms are merely generic in nature.

Term	Definition
Analog	Refers to a continuously variable signal or a circuit or device designed to handle such signals.
Band	Frequencies allowed for a specific purpose.
CMOS	Complementary Metal Oxide Semiconductor.
CPS	Customer Programming Software: Software with a graphical user interface containing the feature set of a radio.
Default	A pre-defined set of parameters.
Digital	Refers to data that is stored or transmitted as a sequence of discrete symbols from a finite set; most commonly this means binary data represented using electronic or electromagnetic signals.
DPL	Digital Private-Line: A type of digital communications that utilizes privacy call, as well as memory channel and busy channel lock out to enhance communication efficiency.
FCC	Federal Communications Commission.
Frequency	Number of times a complete electromagnetic-wave cycle occurs in a fixed unit of time (usually one second).
GPIO	General-Purpose Input/Output.
GPS	Global Positioning System.
IC	Integrated Circuit: An assembly of interconnected components on a small semiconductor chip, usually made of silicon. One chip can contain millions of microscopic components and perform many functions.
IF	Intermediate Frequency.
kHz	kilohertz: One thousand cycles per second. Used especially as a radio frequency unit.
LCD	Liquid-Crystal Display: An LCD uses two sheets of polarizing material with a liquid-crystal solution between them. An electric current passed through the liquid causes the crystals to align so that light cannot pass through them.
LDMOS	Laterally Diffused Metal Oxide Semiconductor.
LED	Light Emitting Diode: An electronic device that lights up when electricity is passed through it.
MDC	Motorola Digital Communications.

Term	Definition
MHz	Megahertz: One million cycles per second. Used especially as a radio frequency unit.
Paging	One-way communication that alerts the receiver to retrieve a message.
PC Board	Printed Circuit Board. Also referred to as a PCB.
PL	Private-Line Tone Squelch: A continuous sub-audible tone that is transmitted along with the carrier.
Programming Cable	A cable that allows the CPS to communicate directly with the radio using USB.
Receiver	Electronic device that amplifies RF signals. A receiver separates the audio signal from the RF carrier, amplifies it, and converts it back to the original sound waves.
Repeater	Remote transmit/receive facility that re-transmits received signals in order to improve communications range and coverage (conventional operation).
RF	Radio Frequency: The portion of the electromagnetic spectrum between audio sound and infrared light (approximately 10 kHz to 10 GHz).
RX	Receive.
Signal	An electrically transmitted electromagnetic wave.
Spectrum	Frequency range within which radiation has specific characteristics.
Squelch	Muting of audio circuits when received signal levels fall below a pre-determined value. With carrier squelch, all channel activity that exceeds the radio's preset squelch level can be heard.
TOT	Time-out Timer: A timer that limits the length of a transmission.
TPL	Tone Private Line.
Transceiver	Transmitter-receiver. A device that both transmits and receives analog or digital signals. Also abbreviated as XCVR.
Transmitter	Electronic equipment that generates and amplifies an RF carrier signal, modulates the signal, and then radiates it into space.
TX	Transmit.
UHF	Ultra-High Frequency.
USB	Universal Serial Bus: An external bus standard that supports data transfer rates of 12 Mbps.
VHF	Very High Frequency.
VIP	Vehicle Interface Port.
XPR	Refers to Digital Professional Radio model names in the MOTOTRBO Professional Digital Two-Way Radio System.



Motorola Solutions, Inc.
1303 East Algonquin Road
Schaumburg, Illinois 60196 U.S.A.

MOTOROLA, MOTO, MOTOROLA SOLUTIONS and the Stylized M Logo are trademarks or registered trademarks of Motorola Trademark Holdings, LLC and are used under license. All other trademarks are the property of their respective owners. © 2011 Motorola Solutions, Inc. All rights reserved. December 2011.

www.motorolasolutions.com/mototrbo



68009515001-A