

UNIVERSAL ELECTRIC
VEHICLE CHARGER

Up to 7.2kW Universal Charging Socket



Model No.
EVON0010
EVON0040



INSTALLATION & USER GUIDE

Thank you for choosing to charge with QUBEV. Inside you will find some useful hints and tips as we want your experience with the QUBEV to be as smooth as possible!

REF: QUBEV-UG-02

Amendments

Amendment Number	Details	Date
Ver 2, Rev 0	New Document.	November 2020

Product:	QubeV Universal Socket EV Charging Unit		
Applicable Models:	EVON0010	EVON0040	
Document Type:	Installation and Operation Manual		
Document Code:	QUBEV-UG-02		
Language:	UK English (Original)		
Date Published:	November 2020		
<p>QubeV are the publishers of this document and own the rights to use the text, images and all technical content contained within. Content supplied by third parties / partner organisations remains the property of that organisation and is used by agreement with the supplier.</p> <p>QubeV exercise care to ensure content is as accurate as possible at the time of publication. However, no guarantee of accuracy should be inferred.</p>			
<p>QubeV www.qubev.co.uk</p>			

Contents

Contents	3
Support	3
Safety	4
Safety Advice within this Manual	5
Product Specification	5
Physical Specification	5
Electrical Specification	6
Certifications and Compliances	6
Unpacking	6
Typical Contents	6
Typical Options	7
Installation	7
Before Installation	7
Labelling	8
Schematics	8
Installation Procedure	10
Commissioning	11
Set the Charger Power	11
AMP Setting Record	12
Testing	12
After Installation	13
Operation	13
Charger Status Indications	13
Maintenance	14
Disposal	14
Warranty	15

Support



For assistance with the installation or operation of this product, contact Technical Support. Please have the details of the product available so we can attend to your query appropriately:

www.qubev.co.uk

Safety

This manual is specifically applicable to the QubEV electric vehicle charging product and is provided as a guide to its installation and operation.

Failure to install and operate the QubEV in accordance with these instructions may damage the unit and invalidate the manufacturer's warranty.

	<p>WARNING: Electrical Power Make sure electrical power is isolated BEFORE starting this procedure.</p> <ul style="list-style-type: none"> • Turn power OFF at SOURCE.
	<p>IMPORTANT: Installers and End Users must read and understand the content of this manual before installation and/or use of the product.</p>
<p>Installation must only be performed by someone who is properly qualified and competent to do so in accordance with the current legislation in force in the geographical location of the installation.</p> <ul style="list-style-type: none"> • If the advice in this manual is not understood, contact the distributor for further advice and/or training BEFORE attempting installation/operation of the equipment. • The manufacturer/distributor cannot accept any responsibility for improper installation or any problems arising from improper installation. 	
<p>NOTE: Damage to the equipment, connected systems or to property caused by improper installation are the responsibility of the installer.</p>	

- The information provided in this manual must ONLY be used with the model(s) listed on page 2 of this manual.
- The information provided in this manual must NOT be used with any other product.
- The content of this manual may be updated as required.
- Do NOT use the equipment for anything other than its intended purpose.
- Do NOT modify the equipment unless specifically instructed to do so by the manufacturer.
- Do NOT attempt to repair the equipment unless specifically instructed to do so by the manufacturer.
- To maintain electrical safety, the body enclosure of the product (access covers) must be secured in their correct location using the supplied fasteners and the seal must be sufficient to maintain the IP rating of the enclosure.
- Fasteners used to mount the product in its working location must be sufficient for the task and the specific mounting point.
- If required, fasteners used to mount the product in its working location should be sealed to maintain the IP rating of the enclosure.
- Cable entry apertures should be sealed with an appropriate cable gland(s) to maintain the IP rating of the enclosure.
- Damage to the body enclosure, access covers, seals may render the product unsafe. The product must be electrically isolated and NOT used until appropriate remedial action has been performed.

Safety Advice within this Manual

This manual uses a system of warnings, cautions and notes.

- **WARNINGS** concern the safety of installers/end user and will be given before the detail/instructions in the manual.
- **CAUTIONS** concern the potential for damage to the equipment and will be given before the detail/instructions in the manual.
- **NOTES** are given to provide additional information and/or to highlight information of importance. They will be given either before or after the detail/instructions as appropriate and may use different wording (such as IMPORTANT) where emphasis is required.

Warnings, Cautions and Notes may be repeated several times as appropriate and may be preceded by a hazard symbol where appropriate.

Product Specification

Physical Specification

Dimensions	150mm x 200mm x 100mm (W x H x D)
Materials	ABS (UL94 HB Fire Rated), IK08
Mass	<2.0kg
Operating Temperature	-20°C to +50°C
Protection	IP65 - Enclosure, IP54 - Socket

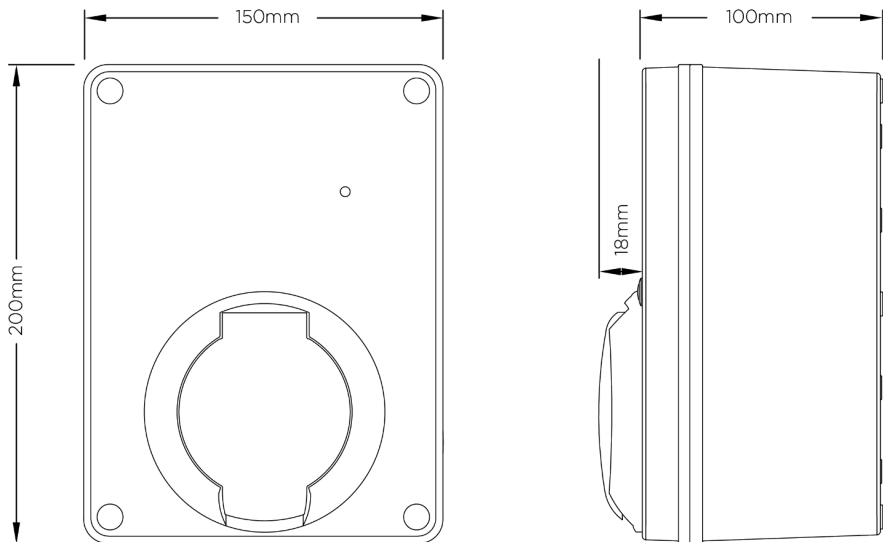

Figure 1 General Arrangement and Dimensions

Electrical Specification

	EVON0010	EVON0040
Description	QUBEV Universal Socket EV Charging Unit	QUBEV Universal Socket EV Charging Unit
Rated Output	Up to 7.2kW (32A)	
Rated Current	Up to 32A max	
AC Overload Protection	N/A	1x C40A MCB
AC & DC Fault Protection	N/A	Type B RCD
Charging Current	Variable - 6A, 20A, 25A & 32A	
Input Voltage	230V AC/50Hz (Single Phase)	
Incoming Cable Terminals	3 x 16mm terminals	
Overcurrent Protection	Recommended 40A	
Charging Socket	IEC 62196 (Type 2)	
Charge Protocol	Mode 3	

Certifications and Compliances

This product has been designed and built in accordance with the following standards and legislation:

EV Charging Compliance	EN 61851-1:2001, EN 61851-21:2002, EN 61851-22:2002
Wiring Regulations	BS 7671
IET EV Regulations, Glow Wire Testing	IEC 60695-2-13
EMC Compliance	2014/30/EU, EN 61000-6-3:2007, EN 61000-6-2:2005
Safety Compliance	EN 60950-1:2006, EN 60950-22:2006
Low Voltage Directive (LVD)	2014/35/EU
Metal Enclosure (where supplied)	EN 55014-1: 2006+A1: 2009+A2: 2011, EN 55014-2: 2016 EN 61000-3-2:2014, EN 61000-3-3:2014 EN 60335-1: 2012+A11: 2014
Switchgear (where supplied)	EN 61543: 1995/+A11: 2003/+A12: 2005/+A2: 2006 EN 61008-1: 2010+A1+A2, EN 61008-1: 2012+A1+A2+All+A12 EN 61008-2-1:1990, EN 61008-2-1:1994+A11 EN 62423:2009, EN 62423:2012



Unpacking

The content of the package depends on any options or accessories that may have been selected.

IMPORTANT: Make sure all packaging is disposed of responsibly and in accordance with the current regulations in your region.



Typical Contents

- 1 x EV Charging Device.
- 1 x Installation and Operators Manual.
- 1 x Fixing Template.
- 4 x Wall Plugs.
- 4 x Washers.
- 4 x Fixings.

Typical Options

- EV charging cables (Type 1 to Type 2 or Type 2 to Type 2)
- Charge point signage

Installation

	<p>WARNING: Electrical Power Make sure electrical power is isolated BEFORE starting this procedure.</p> <ul style="list-style-type: none"> • Turn power OFF at SOURCE.
	<p>IMPORTANT: Installers and End Users must read and understand the content of this manual before installation and/or use of the product.</p>
<p>Installation must only be performed by someone who is properly qualified and competent to do so in accordance with the current legislation in force in the geographical location of the installation.</p> <ul style="list-style-type: none"> • Advice provided in this manual does NOT override any legislation. • If the advice in this manual is not understood, contact the distributor for further advice and/or training BEFORE attempting installation/operation of the equipment. • The manufacturer/distributor cannot accept any responsibility for improper installation or any problems arising from improper installation. 	
<p>NOTE: Damage to the equipment, connected systems or to property caused by improper installation are the responsibility of the installer.</p>	

Before Installation

1. Establish a suitable site location for the unit that is both secure and environmentally safe.
2. Make sure the location meets current legislation (if applicable).
3. Make sure there is a suitable mains power supply available at the installation site.
4. Make sure the unit model is correct and matches the order.
5. Make sure the unit and any accessories do not appear to have been damaged in transit.
 - Further detail is provided in the Installation procedure.
6. Make sure the supplied fixings are suitable for the mounting location. If not suitable, alternatives must be obtained locally before proceeding with the installation.

Labelling

Installers must observe any/all warning labels displayed on the equipment or inside the equipment enclosure.

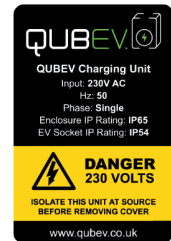

Figure 2 Product Label

Schematics

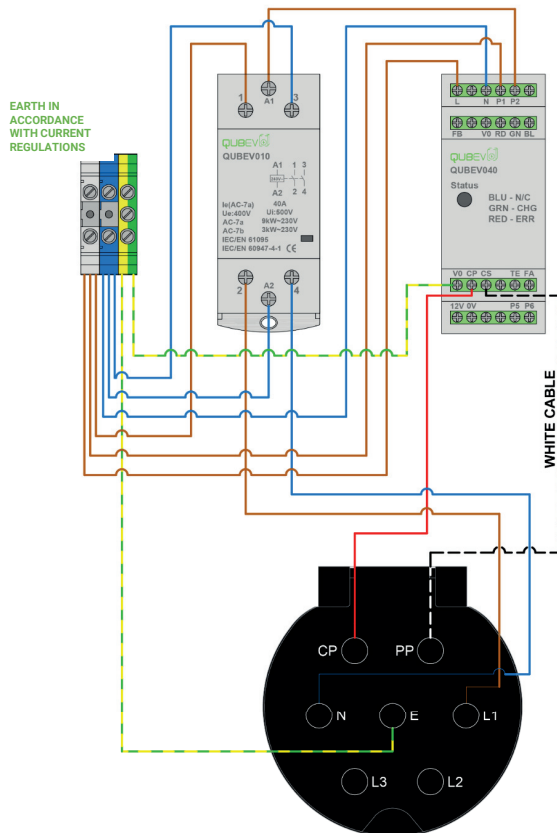

Figure 3 EVON0010 - Schematic Diagram

Installation Procedure

**WARNING: Electrical Power**

Make sure electrical power is isolated BEFORE starting this procedure.

- Turn power OFF at SOURCE.

NOTE: All electrical work must be performed in accordance with the current Electrical Wiring Regulations.

CAUTION: Equipment Damage

During the next steps, the charger front panel will be removed. Take care to not damage or strain cables or cable connections that run between the chassis and the front panel.

1. Remove the QubEV from the packaging.
2. Remove and retain the fixings that secure the front panel to the charger body.
3. Carefully ease the front panel away from the charger body to gain access to the interior.

CAUTION: Equipment Damage

The front panel is connected to the charger body by electrical cables. Take care not to damage, strain, or disconnect the cables. At the end of the procedure, make sure all connections are secure before refitting the panel.

4. Visually inspect the QubEV and internal components.
 - Components that have come away from the DIN rail may be refitted to the rail if there is no damage to the component or its securing mechanism.

IMPORTANT: Items damaged in transit must first be reported to the courier and then to the supplier.

- Where possible, photographic evidence of package and/or unit damage should be provided.
- Incorrect or damaged units must NOT be installed. Contact your supplier to discuss rectification.

5. Remove the fixing template from the packaging.
6. Use the fixing template to mark the mounting position.
 - Offer the QubEV fixing template up onto a flat and smooth surface.
 - Make sure it is orientated correctly and is level.
 - Mark the 4 fixing holes onto the surface.
7. Drill 4 x marked fixing holes and insert the wall plugs.
8. Make note of the position of the electrical connection terminations within the charger body.
9. Cut a neat hole in the charger body to allow entry of the power cable.
 - Ideally, the cable should enter the charger body from below.
 - A suitable cable gland must be used to maintain the IP integrity of the unit.
10. Make sure all debris is removed from the charger body.
11. Secure the charger body to the mounting location with the appropriate fixings.

NOTE: All electrical work must be performed in accordance with the current Electrical Wiring Regulations.

12. Route the power supply cable to the appropriate length to be able to connect to the terminals.
13. Terminate the supply cable in the appropriate manner and connect to the pedestal as per the appropriate schematic.
14. Make sure ALL cable connections are secure and have not become loose or damaged in transit or during installation.
15. Make sure ALL debris is removed from the front and rear halves of the charger body and that no debris is present on any of the components.

IMPORTANT NOTE:

It is the responsibility of the installing engineer to satisfy themselves, that all cable terminations throughout this product are secure and tight and have not become loose, strained, or disconnected during transit and/or installation.

Commissioning

WARNING: Electrical Power

Make sure it is safe to apply electrical power to the charger.

Set the Charger Power

By default the QubEV charger is set to 32 Amps. If a lower power is required, refer to the steps below:

1. Carefully remove the cover of the Charge Control Unit and locate the Amp Setting 'DIP' switches. Refer to Figure 5 Charge Control Unit.
2. Set the switches to the appropriate position for the required power rating:

WARNING: Electrical Power

Switches must only be set by a qualified electrical installer. Incorrect setting may lead to equipment damage and/or personal injury. The current rating must not exceed the supply rating.

Carefully squeeze the top and bottom faces of the Charge Control Unit (as indicated by the green arrows) and ease the top cover away.

With the cover removed, the DIP switches can be seen toward the bottom edge of the unit.

Make sure to refit the cover when setting is complete.

The setting may be recorded for future reference on the next page:

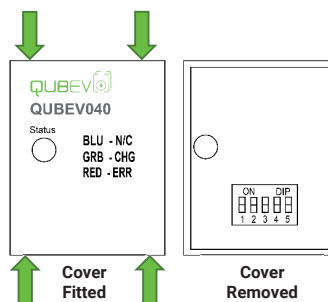

Figure 5 Charge Control Unit

AMP Setting Record

Charger Serial Number: _____

10 Amp



Name: _____

Signature: _____

Date: _____

16 Amp

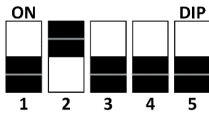

Name: _____

Signature: _____

Date: _____

20 Amp

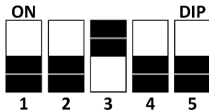

Name: _____

Signature: _____

Date: _____

25 Amp

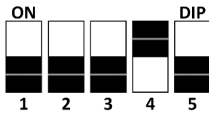

Name: _____

Signature: _____

Date: _____

32 Amp

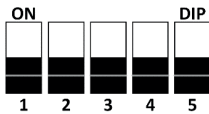

Name: _____

Signature: _____

Date: _____

3. Installers may add their name and the date of installation/setting as a record of the work.
4. Refit the Charge Control Unit cover.

Testing

WARNING: Electrical Power

Testing may require power to be applied whilst the front panel is removed. If this is not required, replace the front panel NOW.

1. Switch ON the power to the unit and test in accordance with the current Electrical Wiring Regulations.
 - Make sure this product has been installed in compliance with the current Electrical Wiring Regulations (including recommended earthing arrangements).
2. Make sure you are satisfied that the installation is complete and is in a safe condition.
3. Refit the front panel, taking care not to trap any electrical cables. Secure the panel with the fixings removed earlier in the process.

After Installation







Make sure this manual and any other relevant documentation is given to the End User.

Operation

NOTE: At the end of a charging session, always disconnect the cable from the vehicle **before** disconnecting from the charger.

Charger Status Indications

The charger status indicator is located above the charging socket.

	No Light	No power to charger or Charger fault.
	Steady Blue	Charger available and ready to be connected to vehicle.
	Flashing Blue	Connection is okay.
	Steady Green	Charging.
	Flashing Green	Charging complete.
	Steady Red	Electric vehicle requires heat dissipation, STOP charging.
	Flashing Red	Fault – Not charging.

1. Make sure the Charge Status Indicator is illuminated **Steady Blue**.
2. Insert the cable into the vehicle first and then into the QubEV charger socket.
3. The Charge Status Indicator will illuminate **Steady Green** when charging is in progress.
4. To STOP charging, unplug the cable from the vehicle, and then from the QubEV charger.

Maintenance

NOTE: In the event of a hardware issue, always contact your installer first.

- Damage caused to the equipment by misuse, lack of maintenance, inappropriate maintenance or modification is not covered by the manufacturer warranty.



WARNING: Electrical Power

The charger enclosure does NOT need to be opened for routine maintenance tasks.

1. Regularly clean the external surfaces of the equipment with a damp cloth.

CAUTION: Equipment Damage

To avoid damage to the surface finish, and/or internal components do NOT use:

- Abrasive materials.
- Mineral or petroleum solvents / degreasers.
- Hose pipes, Jet washers or Steam cleaners.

2. Regularly inspect the exterior of the equipment for visual damage.
 - If damage affects safety, isolate the equipment and prevent its use until appropriate repairs have been completed.
3. Perform a functional test of the switchgear (if installed) every six months by pressing the test button and making sure that the switchgear deactivates.
 - If the equipment fails the test, isolate the equipment and prevent its use until appropriate repairs have been completed.
4. Once a year, the charger and switchgear (if installed) should be electrically inspected by an appropriately qualified electrician in accordance with the current legislation for the installation location. A record of the tests and results must be kept.
 - If the equipment fails the test, isolate the equipment and prevent its use until appropriate repairs have been completed.

Disposal

In accordance with European Directive 2002/96/EC on waste electrical and electronic equipment and its implementation in national law, used electrical devices must be collected separately and recycled in an environmentally responsible manner.

Ensure you return your used device to your dealer or obtain information regarding a local, authorised collection and disposal system. Failure to comply with this EU Directive may result in a negative impact on the environment.



Warranty

Subject to the provisions described below, this product is protected for one (1) year from the date of purchase against defects in material and workmanship.

Prior to returning any defective product to QubEV, the end customer must report the faulty product to QubEV. Go to www.qubev.co.uk for return details. If QubEV agrees that the product should be returned, it will issue a Return Authorisation number. This number must be clearly marked on the packaging of the product to be returned. QubEV may provide a prepaid label at its discretion, otherwise the customer should return the product at their own cost.

Should the product fail to perform as described within the relevant warranted period as set out above, it will be repaired or replaced with the same or functionally equivalent product by QubEV, at its discretion, free of charge provided the end customer: (1) returns the failed product to QubEV with shipping charge prepaid, and (2) provides QubEV with proof of the original date of purchase. Returned or replacement products will be returned to the end customer with shipping charges prepaid.

Replacement products may be refurbished or contain refurbished materials. If QubEV, by its sole determination, is unable to repair or replace the defective product, it will replace or refund the depreciated purchase price of the product.

The warranty does not apply if, in the judgement of QubEV, the product fails due to damage from shipment, handling, storage, incorrect installation, accident, inappropriate use or cleaning of the product, relocation of the product after its first installation, abuse, misuse, or if it has been used or maintained in a manner not conforming to product manual instructions, has been modified in any way, or has had any serial number or other identification markings removed or defaced.

Repair by anyone other than a qualified electrician will void this warranty. All defective products should be returned to QubEV with shipping charges prepaid, unless QubEV have provided a prepaid label. QubEV will not supply prepaid returns labels outside of the UK.

Should an issue be found with your unit QubEV will return your repaired/replaced unit free-of-charge to any UK address. Should the return address be outside of the UK return postage will be at QubEV's discretion. If the unit is found not to be defective return postage will need to be paid for by the customer.

Nothing in this agreement will affect the end customer's statutory rights, or limit or exclude QubEV's liability for (1) death or personal injury caused by its negligence, or the negligence of its employees, agents or subcontractors (as applicable); (2) fraud or fraudulent misrepresentation; (3) defective products under the Consumer Protection Act 1987; or (4) any matter in respect of which it would be unlawful for QubEV to exclude or restrict liability.

The maximum liability of QubEV under this warranty is limited to the purchase price of the product covered by the warranty.

QubEV only supply products for resale for domestic, light commercial and private use. QubEV accept no liability to the end customer for any loss of profit, loss of business, business interruption, loss of business opportunity or travel time incurred.

QUBEV

SIMPLE · COMPACT · AFFORDABLE



British by Design

Images are for marketing purposes only and are not contractual.