



Universal Electric Vehicle Chargepoints

7.4kW or 22kW Models

Amendments

Amendment Number	Details	Date
Ver 1, Rev 0	New Document.	February 2023

Product:	Universal Electric Vehicle Chargepoints		
Applicable Models:	Single-Phase	Three-Phase	
	EVON0040	EVON0080	
Document Type:	Installation and Operation Manual		
Document Code:	QUBEVM-V01-R0		
Language:	UK English (Original)		
Date Published:	February 2023		
<p>One Stop Europe AB are the publishers of this document and own the rights to use the text, images and all technical content contained within. Content supplied by third parties / partner organisations remains the property of that organisation and is used by agreement with the supplier.</p> <p>OneStop exercise care to ensure content is as accurate as possible at the time of publication. However, no guarantee of accuracy should be inferred.</p>			
<p>www.qubev.com One Stop Europe AB Mallslingan 20A, 187 66 TÄBY, Sweden</p>			

Contents

Support	2
Safety	3
Safety Advice within this Manual	3
Product Specification	4
Physical Specification	4
Electrical Specification	6
Certifications and Compliances	6
Labelling	7
Unpacking	7
Typical Contents	7
Typical Options	7
Installation	8
Before Installation	8
Schematic Diagrams	9
Installation Procedure	11
Commissioning	13
Set the Charger Power	13
Completion	13
After Installation	14
Operation	14
Charger Status Indications	14
Charge a Vehicle	14
Maintenance	15
Fault Diagnosis	16
Disposal	16
Warranty	17

Support

For assistance with the installation or operation of this product, contact your preferred electrical installer.



Translations of this manual are available online from:
www.qubev.com/downloads



Safety

This manual is provided as a guide to installation and operation and is specifically applicable to the QubEV electric vehicle charger. Failure to install and operate the QubEV in accordance with these instructions may damage the unit and invalidate the manufacturer's warranty.



IMPORTANT: Installers and End Users **must** read and **understand** the content of this manual before installation and/or use of the product.

Installation must **only** be performed by someone who is properly qualified and competent to do so in accordance with the current legislation in force in the geographical location of the installation.

- The manufacturer/distributor cannot accept any responsibility for improper installation or any problems arising from improper installation.

NOTE: Damage to the equipment, connected systems or to property caused by improper installation are the responsibility of the installer.

- The information provided in this manual must **ONLY** be used with the model(s) listed on page 1 of this manual.
- The information provided in this manual must **NOT** be used with any other product.
- The content of this manual may be updated by the manufacturer as required.
- Do **NOT** use the equipment for anything other than its intended purpose.
- Do **NOT** modify the equipment unless specifically instructed to do so by the manufacturer.
- Do **NOT** attempt to repair the equipment unless specifically instructed to do so by the manufacturer.
- To maintain electrical safety, the body enclosure of the product (access covers) must be secured in their correct location using the supplied fasteners and the seal must be sufficient to maintain the IP rating of the enclosure.
- Fasteners used to mount the product in its working location must be sufficient for the task and the specific mounting point.
- If required, fasteners used to mount the product in its working location should be sealed to maintain the IP rating of the enclosure.
- Damage to the product may render it unsafe. The product must be electrically isolated and **NOT** used until appropriate remedial action has been performed.

Safety Advice within this Manual

This manual uses a system of warnings, cautions and notes.

- **WARNINGS** concern the safety of installers/end user and will be given before the detail/instructions in the manual.
- **CAUTIONS** concern the potential for damage to the equipment and will be given before the detail/instructions in the manual.
- **NOTES** are given to provide additional information and/or to highlight information of importance. They will be given either before or after the detail/instructions as appropriate and may use different wording (such as **IMPORTANT**) where emphasis is required.

Warnings, Cautions and Notes may be repeated several times as appropriate and may be preceded by a hazard symbol where appropriate.

Product Specification

Physical Specification

	EVON0040	EVON0080
Dimensions (W x H x D)	150 x 200 x 118mm	200 x 200 x 118mm
Materials	ABS (UL94 HB Fire Rated), IK08	
Mass	<2.0kg	
Operating Temperature	-20°C to +50°C	
Protection	IP65 - Enclosure, IP54 - Socket	

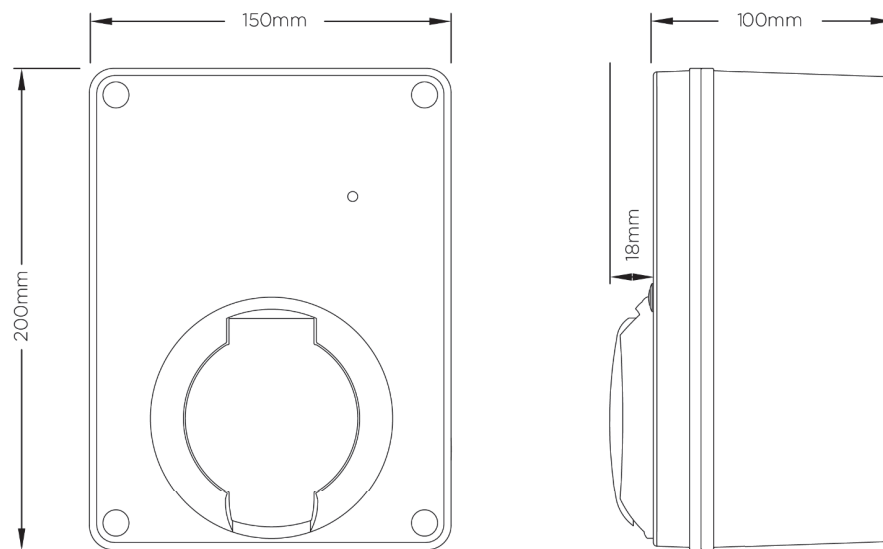

Figure 1 EVON0040 1-Phase Model

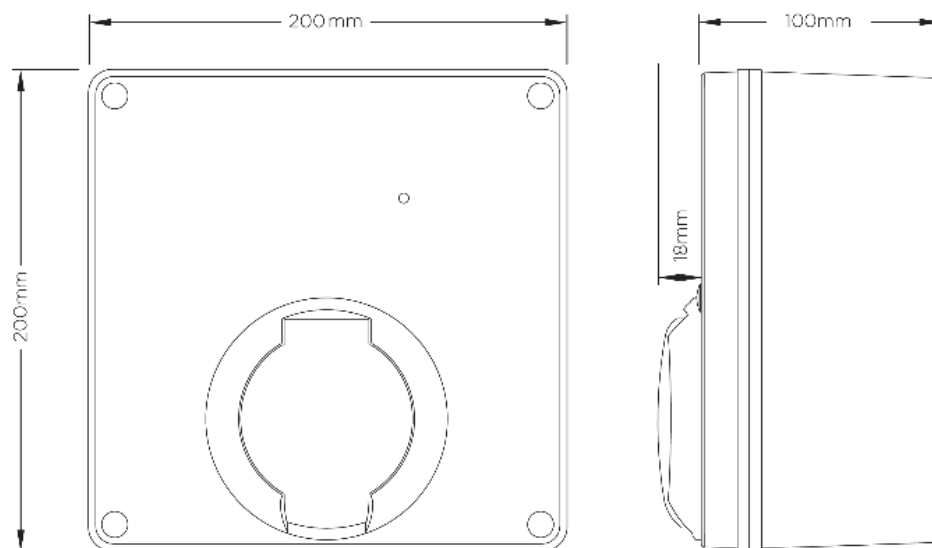

Figure 2 EVON0080 3-Phase Model

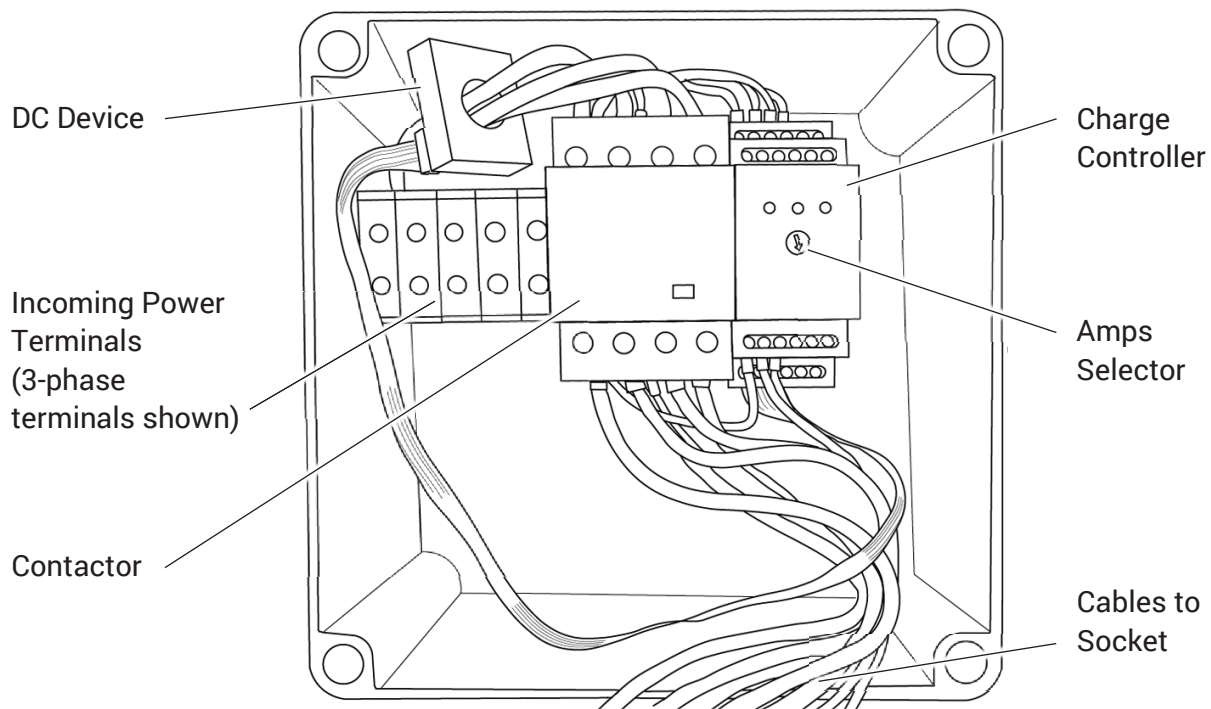

Figure 3 General Arrangement

NOTE: The internal layout of components for the 1-phase and 3-phase models are almost identical, with the exception of the number of terminals for incoming power.

Electrical Specification

	EVON0040	EVON0080
Description	QUBEV Universal Socket EV Charging Unit	
Rated Output	Up to 7.4kW (32A)	Up to 22kW (32A)
Rated Current	Up to 32A max	
DC Fault Protection	6 mA DC Fault Protection	
Charging Current	Variable – 10A, 16A, 20A, 25A & 32A	
Input Voltage	230V AC / 50Hz (1-phase)	400V AC / 50Hz (3-phase)
Incoming Cable Terminals	3 x 16mm Terminals	5 x 16mm Terminals
Overcurrent Protection*	Recommended 40A	
Charging Socket	IEC 62196 (Type 2)	
Charge Protocol	Mode 3	

***NOTE:** A Type 'A' Residual Current Circuit Breaker (RCBO) installed at source is recommended.

Certifications and Compliances

This product has been designed and built in accordance with the following standards and legislation:

EV Charging Compliance	IEC 61851-1:2017, IEC 61851-1:2019
Glow Wire Testing	IEC 60695-2-11:2021
EMC Compliance	2014/30/EU EN IEC 61851-21-2: 2021 EN 61000-3-11:2017, EN 61000-3-12:2011, EN 61000-4-2:2008, EN 61000-4-3:2010, EN 61000-4-4:2012, EN 61000-4-5:2014, EN 61000-4-6:2013, EN 61000-4-8:2009, EN 61000-4-34:2009
Safety Compliance	EN 60950-1:2006+A2:2013, EN 60950-22:2017
Low Voltage Directive (LVD)	2014/35/EU



Labelling

Observe any/all warning labels displayed on or inside the equipment enclosure.

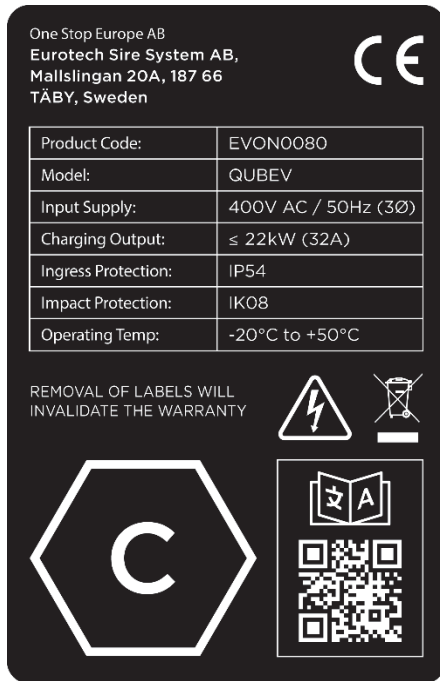

Figure 4 Typical Product Label



Figure 5 Typical Serial Number Label
Includes Month and Year of Manufacture

Unpacking

The content of the package depends on any options or accessories that may have been selected.

IMPORTANT: Make sure all packaging is disposed of responsibly and in accordance with the current regulations in your region.

Typical Contents

- 1 x EV Charging Device.
- 1 x Installation and Operation Manual.
- 1 x Mounting Template.
- 1 x Fixing Kit (4 x Fixings and Wall Plugs).

Typical Options

- EV charging cables (Type 1 to Type 2 or Type 2 to Type 2)
- Charge point signage
- Type A Residual Current Circuit Breaker (RCBO)
- Metal Enclosure for Residual Current Circuit Breaker

Installation



IMPORTANT: Installers and End Users **must** read and **understand** the content of this manual before installation and/or use of the product.

Installation must **only** be performed by someone who is properly qualified and competent to do so in accordance with the current legislation in force in the geographical location of the installation.

- Advice provided in this manual does NOT override any legislation.
- The manufacturer/distributor cannot accept any responsibility for improper installation or any problems arising from improper installation.

NOTE: Damage to the equipment, connected systems or to property caused by improper installation are the responsibility of the installer.

Before Installation

1. Discuss with the customer where the chargepoint is to be installed. This may affect whether the electrical power cable will enter the unit from below or behind the enclosure.
 - Cable entry through the left, right or top of the enclosure is NOT recommended.
2. Identify an installation location for the unit that is both secure and environmentally safe.
 - Whilst the chargepoint is weather resistant in accordance with the required standards, a location that is sheltered from weather extremes will help to maintain that resistance.
3. Make sure the charger will be mounted at an accessible height, that access to the charger is not restricted, and that the charger does not restrict access to other parts of the property.
4. Consider the distance between the charger and the vehicle(s) that will be charged.
5. Make sure the location meets current legislation (if applicable).
6. Make sure there is a suitable electrical power supply available at the installation site.
7. Determine the output power of the charger paying consideration to the incoming power supply and any other factors that may limit the power available for charging.
 - Output power can be adjusted by setting the internal rotary switch as instructed during charger installation.
8. Make sure the unit model is correct and matches the order.
9. Make sure the unit and any accessories do not appear to have been damaged in transit.
10. Make sure the supplied fixings are suitable for the mounting location. If not, alternatives must be obtained locally before proceeding with the installation.
11. Make sure any additional electrical protective devices (such as an RCD, MCB or RCBO) required by regional legislation, have been correctly installed to the power supply.

Schematic Diagrams

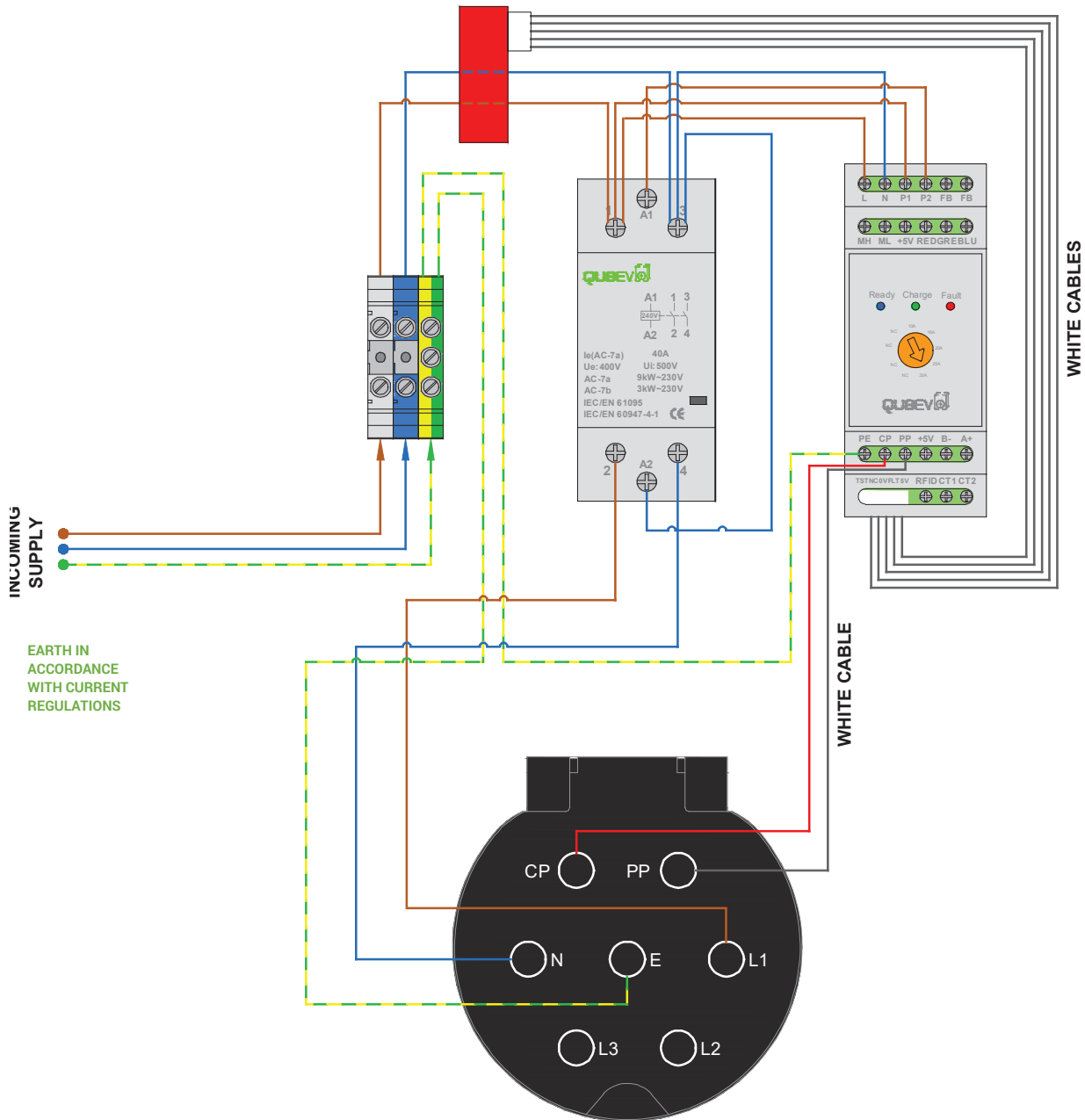

Figure 6 EVON0040 - Schematic Diagram (1-Phase Model)

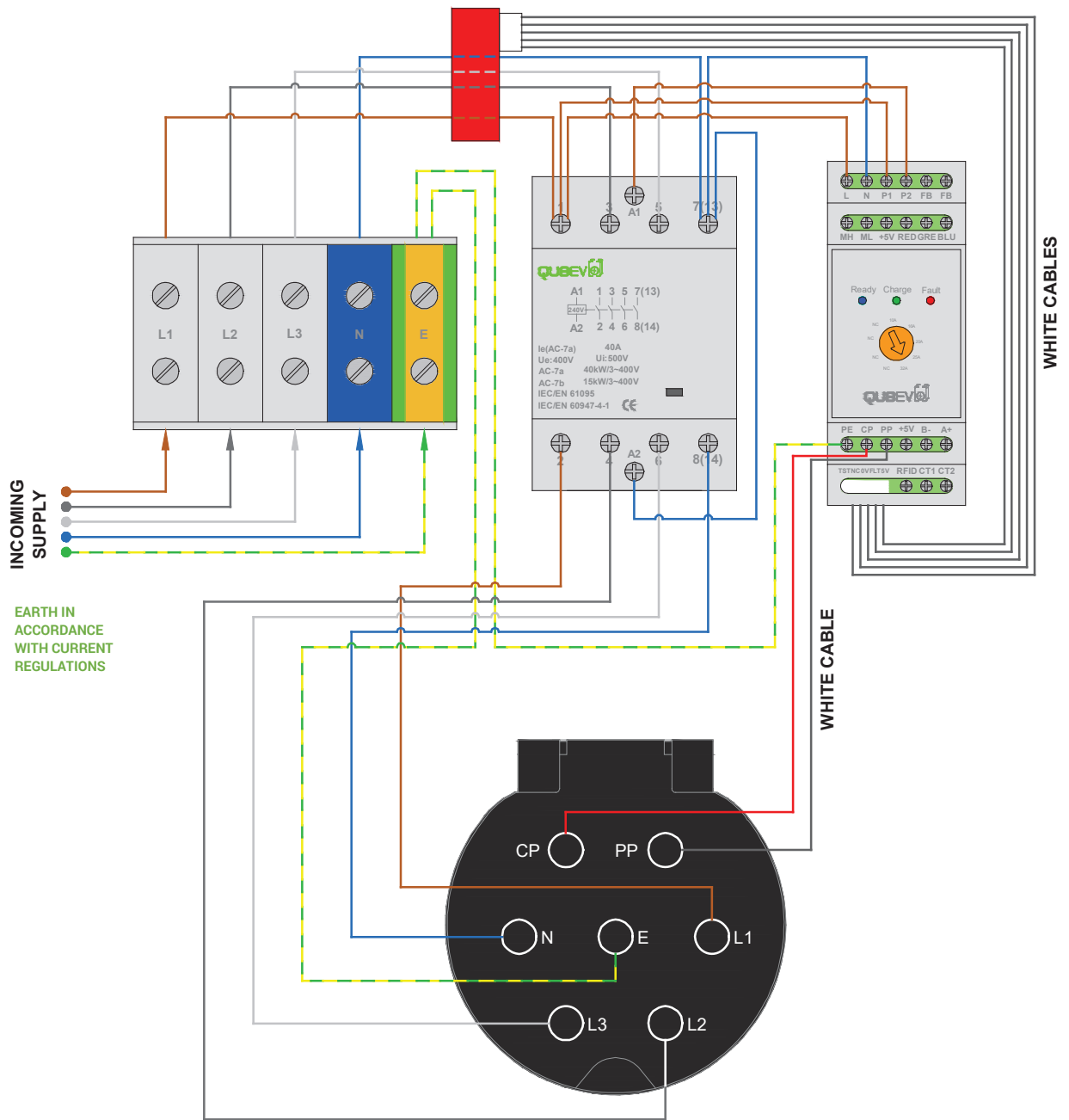

Figure 7 EVON0080 - Schematic Diagram (3-Phase Model)

Installation Procedure

NOTE: All electrical work must be performed in accordance with the applicable Electrical Wiring Regulations for the region of use.

CAUTION: Equipment Damage

During the next steps, the charger front panel will be removed. Take care to not damage or strain cables or cable connections that run between the enclosure and the front panel.

1. Remove the QubEV from the packaging.
2. Release the fixings that secure the front panel to the rear enclosure.
3. Carefully lift the front panel away from the rear enclosure to access to the interior.

CAUTION: Equipment Damage

The front panel is connected to the charger by electrical cables. Take care not to damage, strain, or disconnect the cables. At the end of the procedure, make sure all connections are secure before refitting the panel.

4. Visually inspect the QubEV and internal components.
 - Any components that may have come away from the DIN rail in transit must be refitted to the rail if there is no damage to the component or its securing mechanism.

IMPORTANT: Items damaged in transit must first be reported to the courier and then to the supplier.

- Where possible, photographic evidence of package and/or unit damage should be provided.
- Incorrect or damaged units must NOT be installed. Contact your supplier to discuss replacement or repair.

5. Make note of the location of the incoming power terminals within the enclosure. This will help when positioning the unit to meet the customer's needs.
6. Remove the mounting template from the packaging.
7. Use the mounting template to mark the mounting position.
 - Place the mounting template onto the mounting location (wall).
 - Make sure the template is flat against the wall and is orientated correctly and is level.
 - Mark the 4 fixing holes onto the surface of the wall.
8. Drill the 4 marked fixing holes and insert the wall plugs.
9. Cut a neat hole in the charger body to allow entry of the power cable.
 - Ideally, the cable should enter the unit from below or through the back of the enclosure.
 - A suitable cable gland must be used to maintain the IP integrity of the unit.
10. Make sure all debris is removed from the charger enclosure.
11. Secure the charger enclosure to the mounting location with the appropriate fixings.

NOTE: All electrical work must be performed in accordance with the current Electrical Wiring Regulations.

CAUTION: Equipment Damage – Sensitive Equipment

If you will be performing insulation resistance tests on the power supply cables, it is advised to be done BEFORE connecting the cable to the charger. The high voltages applied during the test may damage sensitive components if tested after the cable is connected.

12. Route the power supply cable to the appropriate length to be able to connect to the terminals.
13. Terminate the supply cable in the appropriate manner and connect to the pedestal as per the schematic.
 - 1-phase models will use the terminals L1, N and E.
 - 3-phase models will use the terminals L1, L2, L3, N and E.
14. Make sure ALL accessible cable connections are secure and have not become loose or damaged in transit or during installation.
15. Make sure ALL debris is removed from the front and rear halves of the enclosure and that no debris is present on any of the components.

IMPORTANT NOTE:

It is the responsibility of the installing engineer to make sure, that all accessible cable terminations throughout this product are secure and tight and have not become loose, strained, or disconnected during transit and/or installation.

Commissioning

Set the Charger Power

WARNING: Electrical Power

The setting of the charger output power (Amps) must only be done by a qualified electrical installer. Incorrect setting may lead to equipment damage and/or personal injury. The current rating must not exceed the rating of the electrical supply.

By default, the QubEV charger is set to 32 Amps. If a lower power is required, refer to the steps below:

1. Make sure electrical power to the charger is OFF.
2. Lift the flap on the front of the Charge Control Unit and locate the Amp Setting Selector.
3. Turn the Amp Setting Selector to the appropriate position for the required output power rating.
 - The new setting will take effect when power is applied to the charger.
4. Close the Charge Control Unit cover.
5. Make a record of the Amps Setting here.

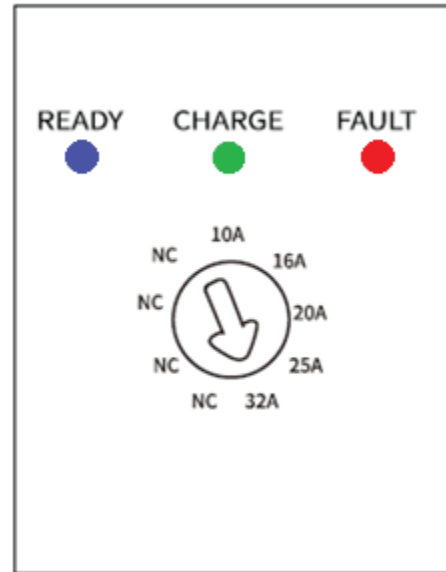

Figure 8 Charge Control Unit

Amps:	
Date:	
Name:	
Signature:	

Completion

WARNING: Electrical Power

Testing may require power to be applied while the enclosure is open.

1. Make sure all accessible terminals are secure and have not become loose during installation.
2. Test in accordance with the current Electrical Wiring Regulations applicable in the region of installation.
3. Make sure you are satisfied that the installation is complete and is in a safe condition.
4. Make sure the rubber seal is flat and secure within its channel in the front panel.
5. Refit and secure the front panel of the enclosure. Take care not to trap any electrical cables.







After Installation

Make sure this manual and any other relevant documentation is given to the End User.

Operation

Charger Status Indications

The charger status indicator is located above the charging socket.

	No Light	No power to charger or Charger fault.
	Flashing Blue	Charger ready for use.
	Constant Blue	Charger connected to vehicle and all systems are okay.
	Glowing Green	Charging.
	Constant or Flashing Red	Fault – STOP charging. • Refer to the Fault Diagnosis table.
	Flashing Red and Blue	Fault – STOP charging. • Refer to the Fault Diagnosis table.
	Flashing Red and Green	Fault – STOP charging. • Refer to the Fault Diagnosis table.

The Fault Diagnosis table shows all fault and operational LED indications.

Charge a Vehicle

NOTE: At the end of a charging session, always disconnect the cable from the vehicle before disconnecting from the charger.

1. Make sure the Charge Status Indicator is illuminated **Flashing Blue**.
2. Insert the cable into the vehicle first and then into the QubEV charger socket.
3. The Charge Status Indicator will illuminate **Constant Blue** to indicate that all systems are okay and will then illuminate **Glowing Green** when charging is in progress.
 - If the Charge Status Indicator **Flashes Green**, the vehicle battery has reached its full charge capacity and the vehicle will stop the charging process.
 - If the vehicle stops the charging process and it is found that the battery does not have a full charge, the vehicle has experienced a problem and has stopped the charging process for another reason that may need to be investigated.
4. To manually STOP charging, unplug the cable from the vehicle, and then from the QubEV charger.

Maintenance

NOTE: In the event of a hardware issue, always contact your installer first.

- Damage caused to the equipment by misuse, lack of maintenance, inappropriate maintenance or modification is not covered by the manufacturer warranty.



WARNING: Electrical Power

The charger enclosure does NOT need to be opened for routine maintenance tasks but, if opened for more thorough testing/maintenance, it must only be done by an appropriately qualified electrical engineer.

1. Regularly clean the external surfaces of the equipment with a damp cloth.

CAUTION: Equipment Damage

To avoid damage to the surface finish, and/or internal components do NOT use:

- Abrasive materials.
- Mineral or petroleum solvents / degreasers.
- Hose pipes, Jet washers or Steam cleaners.











2. Regularly inspect the exterior of the equipment for visual damage.
 - If damage affects safety, isolate the equipment and prevent its use until appropriate repairs have been completed.
3. Any externally installed switchgear may be tested by pressing its built-in test button. When pressed the switchgear should operate to stop the supply of power to the charger.
 - If the switchgear fails to operate correctly, isolate the equipment and prevent its use until appropriate repairs have been completed.

If required, an appropriately qualified electrical engineer may open the enclosure to perform observations and tests.

4. The charger and any additional externally installed switchgear should be electrically inspected (tested) by an appropriately qualified electrician in accordance with the legislation for the installation location.
 - If the equipment fails the test, isolate the equipment and prevent its use until appropriate repairs have been completed.
5. Whenever the enclosure is opened, check the security of accessible cable terminals before closing the enclosure. Temperature changes during the year and when charging, and movement of cables during maintenance may cause cables/terminals to become loose.
 - Make sure power to the charger is OFF.
 - Check the security of ALL accessible terminals.
 - Tighten any terminals that appear loose.
6. Make sure the enclosure is closed securely after work is done.

Fault Diagnosis

In the event of a fault, the Charging Indicator on the front of the charger may show the type of problem.

LED Colour	LED State	Controller State	Remark
 BLUE	1Hz Flashing	Ready	No Fault
 BLUE	Stable	Connected	No fault
 GREEN	Brightening/Glowing	Charging	No fault
 RED	5Hz Flashing	Fault	1. Turn power OFF 2. Turn power back ON
 RED	Stable	Fault	Ventilation/cooling required
 RED	1Hz Flashing	Fault	Possible CP- PE short circuit Check the CP line
 RED	5Hz Flashing	Fault	RCMU leakage or self-inspection failure
 RED	2Hz Flashing	Fault	EV charging socket fault
 RED+BLUE	2Hz Flashing	Fault	Possible PP wire disconnection Check the PP line
 RED+GREEN	1Hz Flashing	Fault	Circuit overload

- **CP** = Control Pilot cable (provides communication between the charger and vehicle)
- **PE** = Earth cable
- **PP** = Proximity Pilot cable (provides cable type information to prevent cable overloads)
- **RCMU** = Residual Current Monitoring Unit

Disposal

In accordance with European Directive 2002/96/EC on waste electrical and electronic equipment and its implementation in national law, used electrical devices must be collected separately and recycled in an environmentally responsible manner.

Make sure you return your used device to your dealer or obtain information regarding a local, authorised collection and disposal system. Failure to comply with this EU Directive may result in a negative impact on the environment.

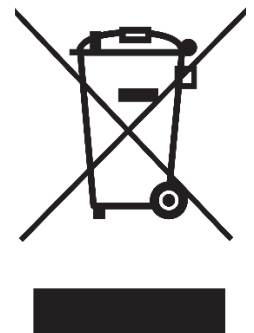

Warranty

Subject to the provisions described below, this product is protected for one (1) year from the date of purchase against defects in material and workmanship.

Prior to returning any defective product to QubEV, the end customer must report the faulty product to QubEV. Go to www.qubev.co.uk for return details. If QubEV agrees that the product should be returned, it will issue a Return Authorisation number. This number must be clearly marked on the packaging of the product to be returned. QubEV may provide a prepaid label at its discretion, otherwise the customer should return the product at their own cost.

Should the product fail to perform as described within the relevant warranted period as set out above, it will be repaired or replaced with the same or functionally equivalent product by QubEV, at its discretion, free of charge provided the end customer: (1) returns the failed product to QubEV with shipping charge prepaid, and (2) provides QubEV with proof of the original date of purchase. Returned or replacement products will be returned to the end customer with shipping charges prepaid.

Replacement products may be refurbished or contain refurbished materials. If QubEV, by its sole determination, is unable to repair or replace the defective product, it will replace or refund the depreciated purchase price of the product.

The warranty does not apply if, in the judgement of QubEV, the product fails due to damage from shipment, handling, storage, incorrect installation, accident, inappropriate use or cleaning of the product, relocation of the product after its first installation, abuse, misuse, or if it has been used or maintained in a manner not conforming to product manual instructions, has been modified in

any way, or has had any serial number or other identification markings removed or defaced.

Repair by anyone other than a qualified electrician will void this warranty. All defective products should be returned to QubEV with shipping charges prepaid. Unless QubEV have provided a prepaid label, QubEV will not supply prepaid returns.

Should an issue be found with your unit QubEV will return your repaired/replaced unit free-of-charge to any UK address. Should the return address be outside of the UK return postage will be at QubEV's discretion. If the unit is found not to be defective return postage will need to be paid for by the customer.

Nothing in this agreement will affect the end customer's statutory rights, or limit or exclude QubEV's liability for (1) death or personal injury caused by its negligence, or the negligence of its employees, agents or subcontractors (as applicable); (2) fraud or fraudulent misrepresentation; (3) defective products; or (4) any matter in respect of which it would be unlawful for QubEV to exclude or restrict liability.

The maximum liability of QubEV under this warranty is limited to the purchase price of the product covered by the warranty.

QubEV only supply products for resale for domestic, light commercial and private use. QubEV accept no liability to the end customer for any loss of profit, loss of business, business interruption, loss of business opportunity or travel time incurred.



THIS DOCUMENT CONTAINS INFORMATION THAT IS SUBJECT TO CHANGE WITHOUT NOTICE.

The latest version of this publication can be downloaded at <http://qubev.com>

Illustrations of the product and user interface are for marketing purposes only.

Brand names, logos and trademarks used herein remain the property of their respective owners. This listing of any firm or their logos is not intended to imply any endorsement or direct affiliation with ONE STOP EUROPE AB. and is purely to demonstrate branding opportunities.

© 2023 by ONE STOP EUROPE AB. All rights reserved.
QUBEVM-V01-R0 QubeEV Installation & Operation Manual - EN

www.qubev.com



UK Office:

sales@evonestop.co.uk
www.evonestop.co.uk

One Stop Europe Ltd, Ralphs Lane, Frampton
West, Boston, Lincolnshire, PE20 1QU

Europe:

sales@evonestop.com
www.evonestop.com

Eurotech Sire System AB, Mallslingan 20A,
187 66 TÄBY, Sweden

