

**DiLUSO**

**Built-in Oven**

**OV604MS**

**Installation and Operating Manual**

# CONTENTS

Important Notes -----Page 2

Technical Specification -----Page 2

Installation Instructions -----Page 3

About the Oven -----Page 5

Oven Mechanical Timer -----Page 6

Manual Mode -----Page 6

Auto-off Timer -----Page 6

Oven Cooking Function -----Page 6

Cooking Time -----Page 8

Cleaning and Maintenance -----Page 9

Warnings -----Page 10

## Important Notes

Dear Customer

Thank you for choosing our product. This appliance is easy to use; however please read this handbook carefully before installing and operating it. Herein, you will find the correct method of installation and tips for best use and maintenance of the product.

Do not use the oven door handle while moving the appliance, such as to move it out from the packing box.

This appliance is designed to be handy for any adult to use at home. Do not allow children to play with it. Children need to be supervised when the product is in operation so that they do not go near the oven and touch the hot surfaces.

Do not touch the heating elements inside the oven.

This product must be connected in accordance with current electrical regulations. A fixed wiring installation is to be done only by an authorised electrician.

Before maintenance or cleaning of the product, disconnect the appliance from the mains and wait for the oven to cool down first.

For any repairs, always contact authorised Customer Service Centre and ask for original spare parts. Repairs by untrained people may lead to damage and void the warranty.

**IMPORTANT! THE APPLIANCE MUST BE CONNECTED IN ACCORDANCE WITH CURRENT ELECTRICAL RULES AND REGULATIONS. INSTALLATION IS TO BE DONE ONLY BY AN AUTHORISED ELECTRICIAN.**

**WARNING! THIS APPLIANCE MUST BE EARTHED.**

**IMPORTANT! AN ISOLATION SWITCH COMPLETE WITH A 15A PLUG SOCKET MUST BE INCORPORATED IN THE FIXED WIRING.**

## Technical Specifications

Product	: <b>OV604MS</b>
Voltage	: (220 – 240) Vac
Frequency	: 50-60Hz
Maximum Power	: 2100W
Oven Capacity	: 70 litres
Power Cable	: 1m length with 10A plug

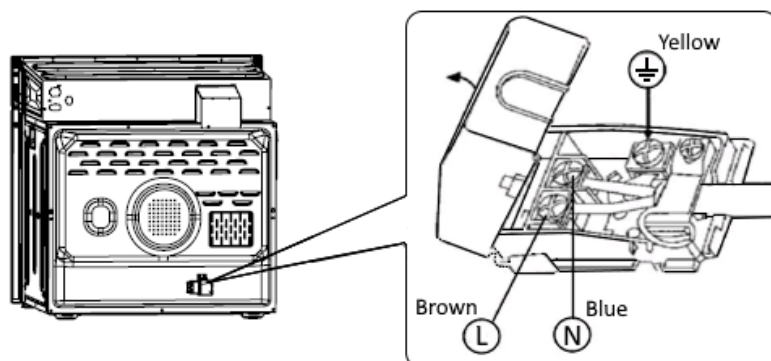

Before connecting to the mains, make sure that:

- The electric meter, safety valve, feeding line and socket are adequate to withstand the maximum load required (refer to product data label for maximum load).
- The supply system earth tested to ensure its working properly.
- The isolation switch can easily be reached after the oven is installed.
- Never use reductions, shunts, and adaptors as they can cause overheating or burning.
- The supply cable is positioned so that it not exposed to temperatures exceed 50°C.

The manufacture shall not liable for any direct or indirect damage caused by faulty installation. The installer must ensure that the product installation and connection complies with the local and general regulation in force.

## Installation Instruction

**IMPORTANT! ENSURE THE POWER IS SWITCHED OFF DURING INSTALLATION OR MAINTAINANCE**

### Built-in Dimensions

The cabinet dimension is in mm

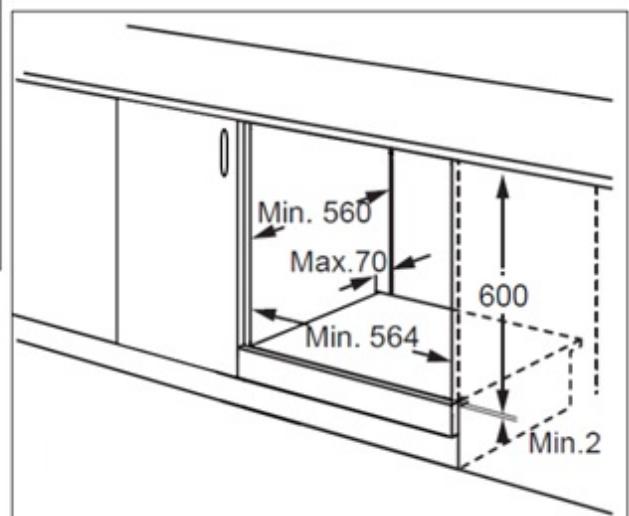
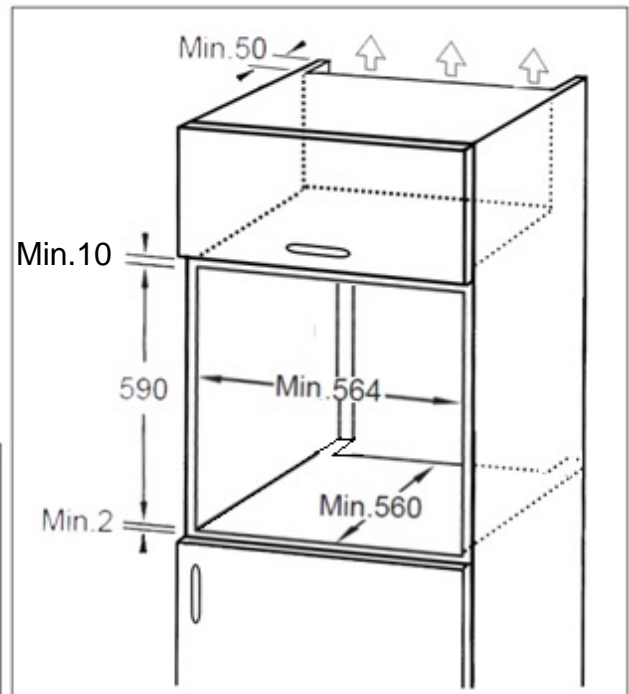
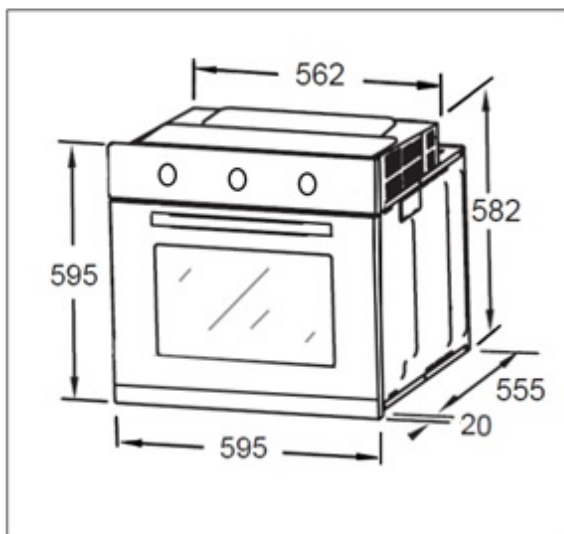

- Secure the appliance to the cabinet frame using the screws provided. Insert it together with the plastic washers into the 2 holes that can be seen in the frame of the oven when the door is open and cap it with the silicone washes.

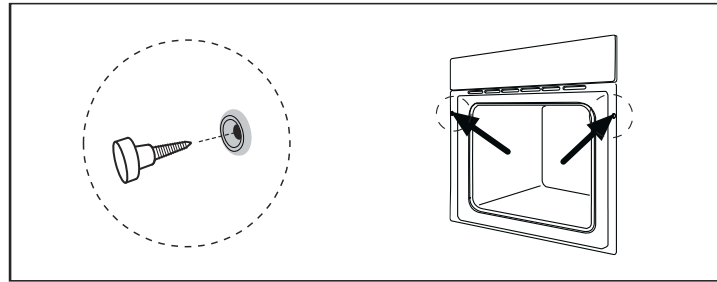

- Ensure the oven is secured firmly in place as described above, and insulate electrical connections in order to avoid contact with metallic parts. Adhesive joining of the cabinets such as laminates and its edgings has to be able to withstand temperatures up to 120°C to avoid deformations or peeling.
- Provide for ventilation (for tall cabinets through the back and top & base cabinets through the back and bottom) to allow sufficient air intake and circulation around the oven, to avoid causing any damage to the furniture.
- For the most efficient air circulation, the oven should be fitted according to the dimensions shown. The rear panel of the cabinet must be removed as well so that air can circulate freely.
- Do not switch on the appliance before it has been fully and correctly installed.

**Before using the oven for the first time, we suggest to:**

- Remove the protective film covering the oven door glass (if any)
- Remove all removable accessories, trays & racks and wash them with dishwashing detergent and dry.
- Heat the empty oven at max. temperature for 45 minutes. This is to remove any unpleasant smell caused by working residues. It may also emit some smoke, which is normal and will stop after awhile.
- Let the oven cool down and clean the internal cavity of the oven with soapy water and wipe it dry.

**IMPORTANT!**

**TAKE NOTE OF THE 'WARNING HOT SURFACE' SIGN.**

**WHEN THE OVEN IS IN OPERATION, THE OVEN DOOR MAY BECOME HOT TO TOUCH. TO PREVENT INJURY OR BURNS TAKE CARE WHEN USING IT.**

**IMPORTANT!**

**MAKE SURE CHILDREN DO NOT GO NEAR THE OVEN WHEN IN USE.**

## About The Oven

The **OV604MS** oven offers extra large capacity of 70L and 4 cooking functions. User can do cooking on up to 5 shelves at a time or cook in large quantity which the traditional ovens do not allow.

A cooling fan that blows a stream of air between the control panel and the oven door will be activated should the area around it rise above 70°C and automatically stops once it drops below 60°C.

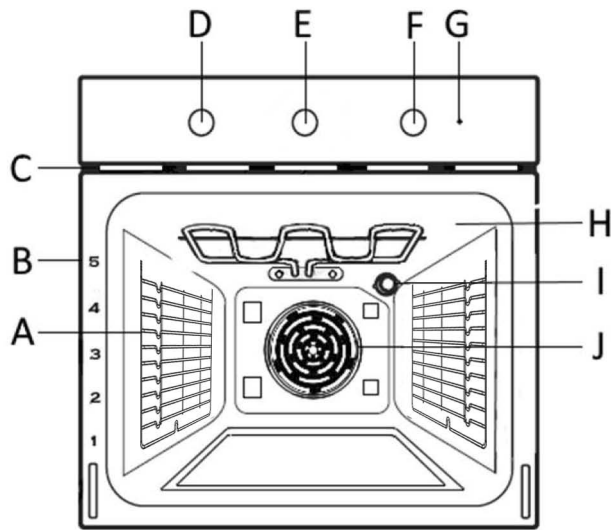

- A - Slider Bracket
- B - Tray Level Marking
- C - Cooling Fan Vent
- D - Function Knob
- E - Oven Timer
- F - Temperature Knob
- G - Temperature Indicator
- H - Upper Heating Element
- I - Oven Light
- J - Oven Fan

## Oven Accessories

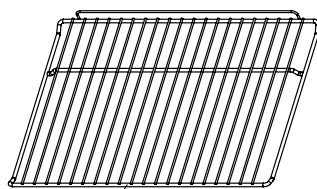

movable rack

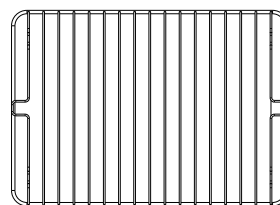

internal rack

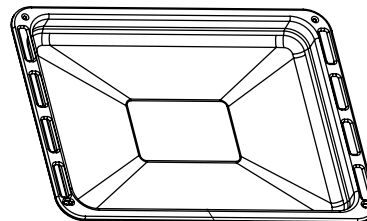

food tray

## Oven Mechanical Timer

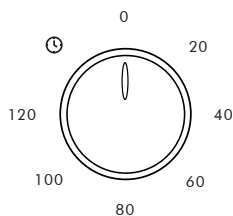

### Manual Mode

**Step 1,** Turn the "Timer Knob" in an anticlockwise direction to the "🕒" symbol on the control panel.

The oven operation is now set in manual mode.

**Step 2,** Turn the "Function Knob" to select the desired cooking function and the "Temperature Knob" to set the required temperature to start cooking.

**IMPORTANT! IN MANUAL MODE THE USER IS RESPONSIBLE TO MANUALLY TURN OFF THE OVEN BY TURNING THE "FUNCTION KNOB" to "0".**

### **CAUTION!**

**FOR SAFETY REASONS, RETURN THE RETURN THE OVEN "TIMER KNOB" TO "0" AFTER USING THE OVEN.**

### Auto-off Timer

Use this function to program the oven to automatically turn off at the end of the cooking duration.

**Step 1,** Turn the "Function Knob" to select the desired cooking function and the "Temperature Knob" to set the required temperature.

**Step 2,** Turn the "Timer Knob" in a clockwise direction to the required time on the control panel (time range is 0-120minutes).

The timer give out a single ring sound once the required time range is completed and the oven automatically turns off

### **CAUTION!**

**FOR SAFETY REASONS, RETURN THE RETURN THE OVEN "FUNCTION KNOB" TO "0" AFTER USING THE OVEN.**

## Oven Cooking Functions

All functions will start working after the temperature is set by using the temperature knob.

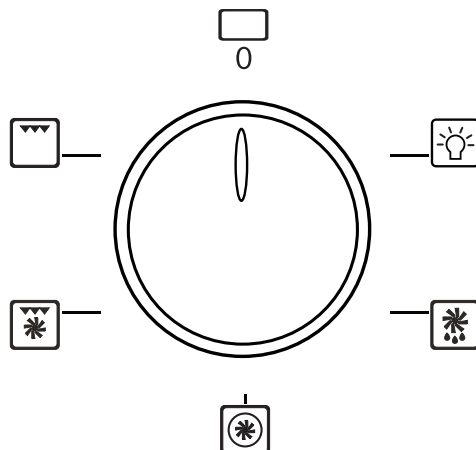



**Oven Light** – Use this function to turn on the oven light when not cooking.



**Defrost** – The fan operates without the heating elements. Can be used to defrost frozen food. The required time for defrosting depends on the type and quantity of food, and the room temperature. Always check food packaging for instructions.



**Fan Forced** – The circular heating element and the fan comes into operation. Heat is distributed evenly to all levels. Several dishes can be cooked on different shelves. Fan forced mode is ideal for baking, cooking large serves of food and cooking different dishes together.



**Grill + Fan** – The top grill element operates with fan assistance. The fan disperses the radiant heat from the elements. Suitable for browning food, whilst keeping it moist. The door must be closed whilst grilling.



**Grill** – The top grill heating element operates. Provides direct heat to the top surface of the food. It is suitable for small portions of foods, e.g. toast. Keep oven door closed when in use.

## **General Advise**

**The oven offers various kind of heating:**

1. The conventional heating for the cooking of special roasts
2. The fan forced heating for the cooking of cakes, biscuits and similar.

If the fan heating is chosen, it is recommended to take advantage of it by cooking on more levels to prepare a complete menu, to save time and energy.

### **Fan heating**

By this function a continuous circulation of warm air is created, suitable for the cooking on multiple levels. The oven will reach the preset temperature in a very short time.

### **Grill Cooking**

To cook with the grill, pre-heat the oven for about 5 minutes. During grill operation the heat comes from above; and its suitable for thin cuts meat and for toasts. The table shows some examples of cooking times and shelf positions. The cooking times vary according to the type of food, its homogeneity and volume.

### **Cooking Of Pastry**

The air circulation of the oven assures an instantaneous and uniform heat distribution. More trays can be inserted into the oven together with the pastries, taking care not to use the top level. Together with the pastry, other foods can be cooked at the same time (fish, meat, etc.), provided they can be cooked at the same temperature.

### **Gratinating (use the Grill Function)**

“Gnocchi alla romana”, polenta pasticciata, rice, lasagnas, noodles and vegetables dressed with béchamel are typical preparation for this type of cooking.



## Pizza or Focaccia

Use a light aluminium tray with a maximum diameter of 30cm, placing it on top of the rack supplied. If the pizza has a lot of toppings, it is recommended to add the mozzarella cheese on top of the pizza halfway through the cooking process.

## Cooking Time

The table shows some examples for the adjustment of the thermostat and of the cooking time.

\*The cooking times can vary according to the type of food, its homogeneity and volume.

\*For the beef, veal, pork and turkey roasts, with bones or rolled, add about 20 minutes to the times shown in the table.

\*The times indicated in the table refer to the cooking of one dish only; for multiple dishes, the cooking times should be increased by 5-10 minutes.

Nature of food	Oven Temp. °C	Time Minutes
General	220--250	Relative to Qty
Long-cooking roast	225--250	50--60
Fowl (duck)	210--250	150--180
Poultry	225--250	50--60
Game	200--225	Relative to Qty
Fish	180--200	20--25
Pastries	160--200	60--70

Food	Qty. Kg	Temp. °C	Pre-heat time in minutes	Time in min.
Veal cutlet	1	250	5	8--10
Lam cutlet	1	250	5	12--15
Liver	1	250	5	10--12
Chopped meat roulades	1	250	5	12--15
Veal heart	1	250	5	12--15
Roast in the net	1	250	5	20--25
Half-chicken	1	250	5	20--25
Fish filet	1	250	5	12--15
Stuffed tomatoes	1	250	5	10--12

## **Cleaning and Maintenance**

### **CAUTION!**

**PRIOR TO CLEANING OR MAINTAINANCE, ALWAYS DISCONNECT THE POWER SUPPLY.**

### **IMPORTANT!**

**REGULARLY CHECK THE CONDITION OF THE SILICONE DOOR SEAL. CLEAN IF NECESSARY AND AVOID USING ABBRASIVE CLEANERS. SHOULD IT BE DAMAGED CONTACT THE AFTER SALES SERVICE CENTRE.**

#### **1) CLEANING OF STAINLESS STEEL**

In order to have your oven retains its new appearance; regular cleaning and care should be performed to protect the s/steel finishes.

Never use gritty or abrasive sponges. Stubborn stains can be removed by soaking in hot water, standard stains can be removed by applying a clean cloth soaked in soapy water before spillage becomes cold or dries up. Acidic materials like vinegar and citric juices etc can damage the most resistant surfaces. If a spill occurs wipe it immediately.

**Note : Use only damp cloth to clean the stainless steel panel with printed wording. Stainless steel cleaners and similar products may remove the print.**

#### **2) OVEN CAVITY CLEANING**

Oven spillages should be cleaned straight away. Leaving it will cause burning and smoking inside the chamber of oven the next time oven is used. Leaving spillage's can cause permanent damage to the enamel thus making it extremely hard to remove in the future. A non-caustic cleaner is recommended to clean the chamber of the oven. Do not use abrasive scourers, sponges, cleaning products. Wipe out oven regularly and properly while oven is still warm with hot soapy water and a soft cloth.

#### **3) TOP HEATING ELEMENT**

This element must never be sprayed with any detergents. A damp cloth and a bottlebrush can be used to clean the roof of the oven and the element itself. Never soak the element and always dry it after cleaning as not doing so can lead to deterioration. This area should be cleaned regularly as cooking fats spit up and stick to the ceiling and the element which will burn and smoke, giving out unpleasant odours.

#### **4) CLEANING OF OVEN DOOR**

Clean the glass door by using damp cloth and dry it. Do not use harsh abrasive cleaners or sharp metal scrapers to clean the oven glass door as they may scratch the surface and cause glass shattering.

#### **5) REMOVING THE OVEN DOOR**

To make it easier to clean the oven chamber, the oven door could be removed.

Open the oven door fully as shown in the figure below. Lift up and turn the small levers B located on the two hinges. Grip the door on the two outer sides and close it approximately half way. Pull the door towards you lifting it out of its seat. To replace the door, ensure the seat D is hooked perfectly onto the edge of the oven slot, and then reverse the above mentioned sequence.

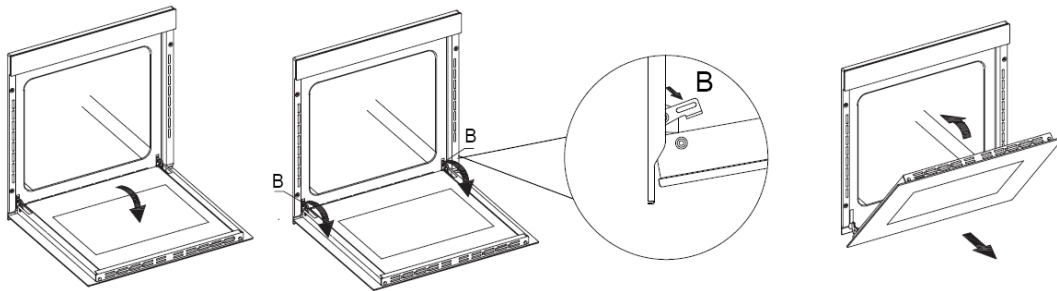
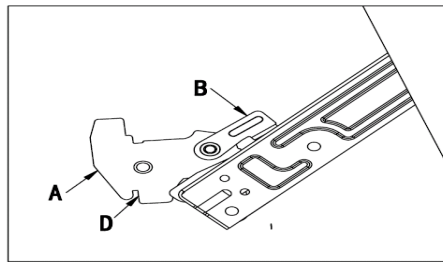

**WARNING!**

**DO NOT USE HARSH OR ABRASIVE CLEANERS, SHARP OBJECTS AND METAL SCRAPERS TO CLEAN THE OVEN DOOR GLASS AS THEY CAN SCRATCH THE SURFACE AND MAY RESULT IN THE GLASS SHATTERING.**

**WARNING!**

**DO NOT USE STEAM CLEANERS.**

**6) REPLACING THE OVEN BULB**

Once the oven has been electrically disconnected, unscrew the glass cover and pull out the halogen bulb.

Replace it with another one suitable for high temperatures of up to 300°C.

Reassemble the glass cover and reconnect the oven.

Bulb Specification: 25W/230Vac , T300°C halogen lamp.

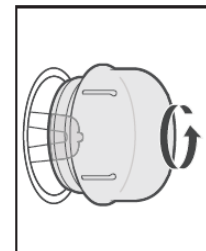

**WARNING!**

**ENSURE THE APPLIANCES IS SWITCHED OFF BEFORE REPLACING THE LAMP TO AVOID THE POSSIBILITY OF ELECTRICAL SHOCK.**

**IMPORTANT!**

**USE A PIECE OF DRY TISSUE WHEN HANDLING THE NEW HALOGEN LAMPS AS OIL FROM FINGERS CAN PERMANENTLY DAMAGE THE SURFACE OF THE BULB GLASS.**

**WARNINGS!**

1. **ACCESSIBLE PARTS MAY BECOME HOT DURING USE. YOUNG CHILDREN SHOULD BE KEPT AWAY.**
2. **ALL FIXED WIRINGS SHOULD BE CORECTLY DONE, WELL INSULATED AND PROTECTED OR CONCEALED.**
3. **NEVER LINE THE OVEN ENAMLE WITH ALUMINIUM FOIL AS THIS WILL LEAD TO EXCESSIVE HEAT ACCUMULATION AND LEAD TO DAMAGE TO THE OVEN ENAMEL.**

4. THE BOTTOM OF THE OVEN DOOR SHOULD BE HIGHER THAN 85MM FROM THE FLOOR.
5. AN ISOLATION SWITCH COMPLETE WITH A 15A PLUG SOCKET MUST BE INCORPORATED IN THE FIXED WIRING. THIS IS TO ENSURE THE APPLIANCE CAN BE SAFELY SWITCHED OFF AND DISCONNECTED FOR SERVICE.
6. WHEN IT IS IN USE THE APPLIANCE BECOMES HOT. CARE SHOULD BE TAKEN TO AVOID TOUCHING THE HEATING ELEMENTS INSIDE THE OVEN.
7. THE CONTROL PANEL IS DESIGNED TO BE CONNECTED TO SPECIFIC HEATING ELEMENTS ONLY. FITTING THE APPLIANCE WITH OTHER THAN ORIGINAL DILUSSO SPARES PART OR CARRYING OUT MODIFICATIONS MAY POSE POSSIBLE HAZZARDS.
8. THE APPLIANCE IS NOT INTENDED FOR USE BY PERSON (INCLUDING CHILDREN) WITH REDUCED CAPABILITIES OR LACK OF EXPERIENCE AND KNOWLEDGE, UNLESS UNDER SUPERVISION BY A PERSON RESPONSIBLE FOR THEIR SAFETY.
9. ALWAYS MAKE SURE THE OVEN CONTROL KNOBS ARE IN Always make sure the knobs are in the "0" POSITION WHEN THE APPLIANCE IS NOT IN USE.

#### **FURTHER ADVICE**

To protect the surrounding furniture cabinets, after cooking is completed, the cooling fan may stay on until the oven has cooled down sufficiently. If you have had the oven on for hours at a time, this fan might stay on for up to 60 minutes after you turn off the oven.

#### **ENVIRONMENT CARE**

Recycle the packaging materials that have the recycling symbol. Put them in the relevant recycling containers according to the material.

This appliance is classified according to European directive 2002/96/EC on Waste Electrical and Electronic Equipment (WEEE). When disposing of old appliances, dispose them at a proper recycling facility. They will handle the disposal in a proper and safe manner in compliance with environmental and local authority regulations.

Help preserve the environment.