

# **DiLUSO**

## Freestanding Steam Oven

**SO633WWFS**

**SO633BBFS**

### **Installation and Operating Manual**

# CONTENTS

Important Notes -----	Page 2
Product Dimension -----	Page 3
Technical Specification-----	Page 4
Steam Oven Overview-----	Page 4
Oven Accessories -----	Page 4
Control Panel -----	Page 5
Adding Water -----	Page 5
Setting Local Time -----	Page 5
Program Cooking -----	Page 6
Recommended Cooking Time -----	Page 8
Cleaning and Maintenance -----	Page 9
Troubleshooting -----	Page 10

## Important Notes

Dear Customer

Thank you for choosing our product. This appliance is easy to use; however please read this handbook carefully before installing and operating it. Herein, you will find the correct method of installation and tips for best use and maintenance of the product.

- This appliance is designed to be handy for any adult to use at home. Do not allow children to play with it. Children need to be supervised when the product is in operation so that they do not go near the steam oven.
- This product must be connected in accordance with current electrical regulations. A fixed wiring installation is to be done only by an authorised electrician.
- Before maintenance or cleaning of the product, disconnect the appliance from the mains and wait for the oven to cool down first.
- For any repairs, always contact authorised Customer Service Centre and ask for original spare parts. Repairs by untrained people may lead to damage and void the warranty.

### ● Power Connection:

THE APPLIANCE MUST BE CONNECTED IN ACCORDANCE WITH CURRENT ELECTRICAL RULES AND REGULATIONS. INSTALLATION IS TO BE DONE ONLY BY AN AUTHORISED ELECTRICIAN.

WARNING: THIS APPLIANCE MUST BE EARTHED.

Main connection can also be made by fitting a single phase 10amp switch with a minimum gap between the contacts of 3mm.

Means for disconnection must be incorporated in the fixed wiring in accordance with the wiring rules.

Before connecting to the mains, make sure that:

- Use 1.0mm<sup>2</sup> power cable and three-pin socket rate 10A
- The electric meter, safety valve, feeding line and socket are adequate to withstand the maximum load required (refer to product data label for maximum load)
- The supply system is regularly earthed, according to the regulations in force.
- The isolation switch can easily be reached after the oven is installed.
- After connection to the mains, check that the supply cable does not overheat.
- Never use reductions, shunts, adaptors that can cause overheating or burning.
- The supply cable must be positioned so that it does not exceed 50°C above room temperature at any point of its length.

The manufacture shall not liable for any direct or indirect damage caused by faulty installation. The installer must ensure that the product installation and connection complies with the local and general regulation in force.

Please flush the built in water reservoir prior to usage if the steam oven has not been used for more than a month.

## Product Dimension

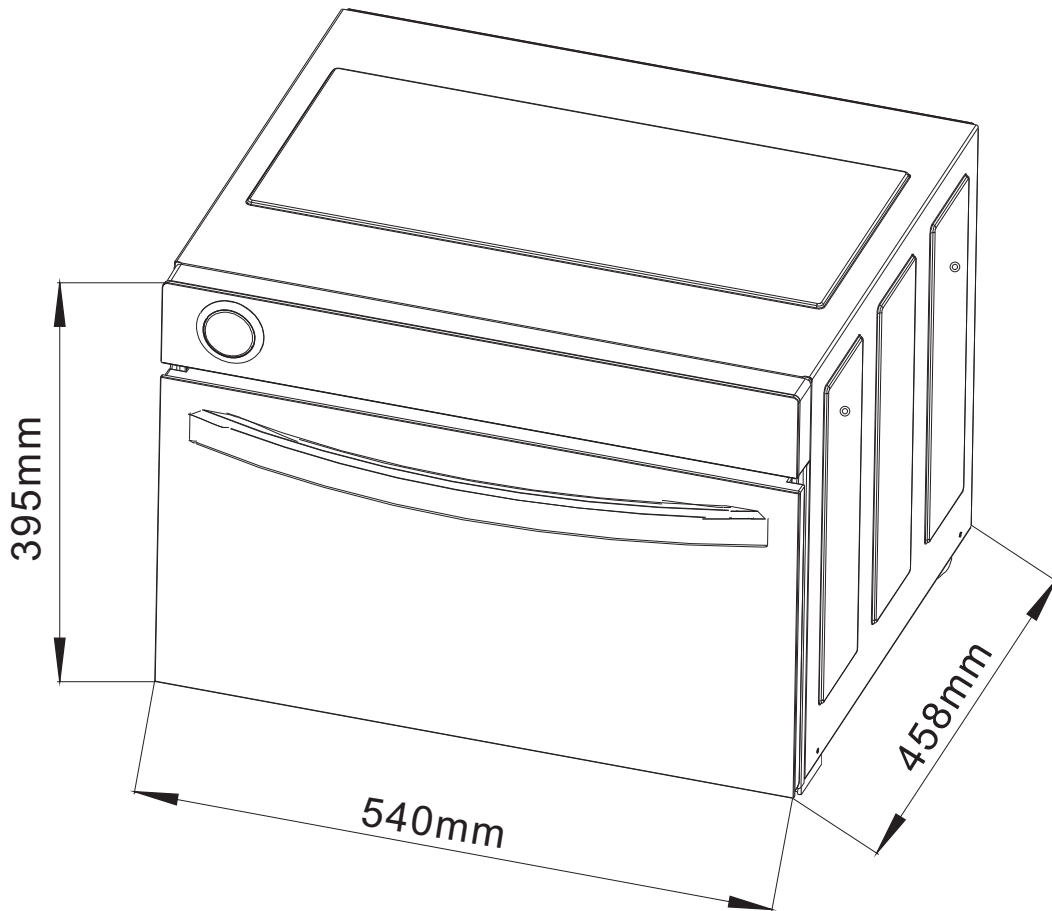

- The steam oven needs a supporting surface underneath.
- The sides and the face surface where the steam oven is to be installed should allow sufficient air intake and circulation around the oven, to avoid causing any damage to the furniture.
- For the most efficient air circulation, the side, top and rear surfaces should have a gap of at least 80 mm from the oven.

Do not switch on the appliance before it has been fully and correctly installed.

### **IMPORTANT!**

The power socket must be connected to a switch with earth leakage protection. If the power cable is damaged, please contact a qualified electrician for replacement.

## Technical Specifications

Product : Freestanding Steam Oven

Model Number: SO633WWFS, SO633BBFS

Voltage: (220 – 240)V a.c.

Frequency: 50Hz

Rated Power: 1625W

Oven Capacity : 33 litres

## Steam Oven Overview

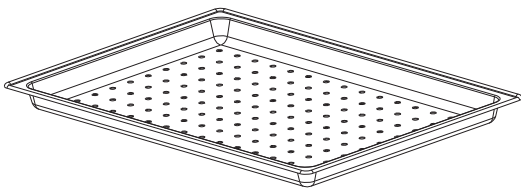
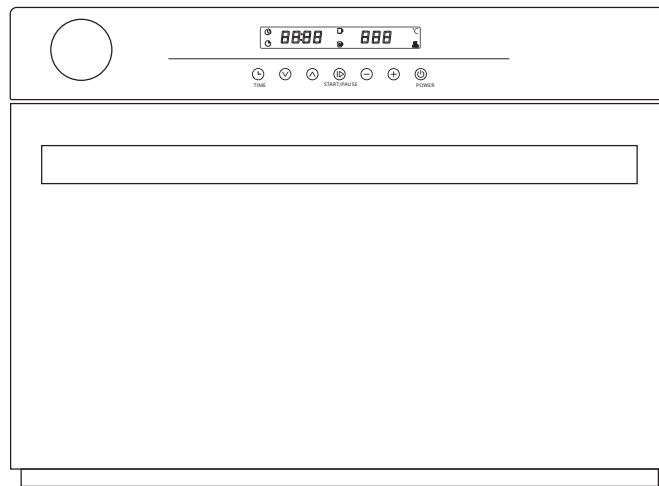

Stainless Steel Perforated Tray

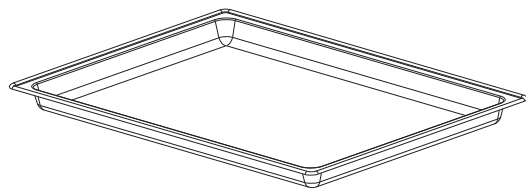

Stainless Steel Solid Tray

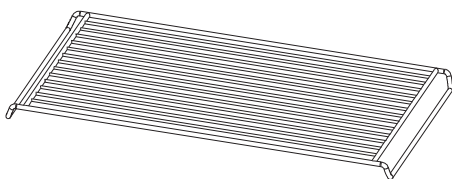

Bottom Rack

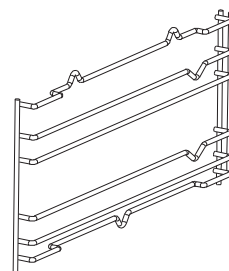

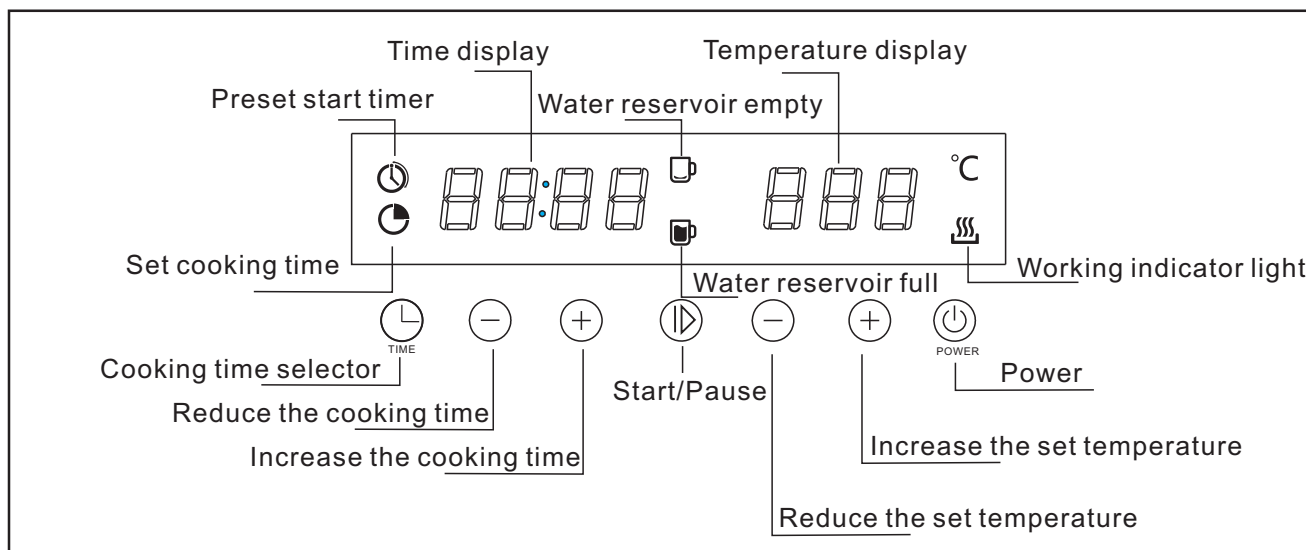

Left/Right side frame

## Control Panel



### Adding Water

Before using the steam oven, we suggest flushing the built in water reservoir. Refer to *Section Cleaning and Maintenance*



- Turn the steam oven on by pressing .
- Push open the water reservoir inlet to access the water filling point then use an appropriate jug to fill with water to the correct level depending on the cooking time required.
- **WARNING: If you live in an area with hard water, it is advisable to use filtered, purified or distilled water.**
- The capacity of the water reservoir is 1.0L, which can last for approx. 1.5hours\*  
Alarm beeps and  will start flashing when the water added reaches maximum water level.

To avoid wasting water or possible spillage, please add only an appropriate amount of water based on the cooking time, e.g. if the cooking time is 30 minutes, then you only need to add about 500ml of water into water reservoir.

\* Time measured for continuous cooking condition in laboratory.







Note : Water could be added even though cooking is in process. This will not disturb the programme.

### Setting the Local Time

- Turn the steam oven on by pressing .
- Press TIME button three times and  &  will go off. At this time, no other icon symbols are flashing, only the time display digits flashes.
- Press “+” or “-” next to the TIME button to adjust the value.
- Press TIME button again to confirm and save the local time.

## **Program Cooking**

### **Setting the Cooking Duration & Temperature**



- Turn the steam oven on by pressing .
- Press TIME button once and the time display digits flashes. At this time,  icon is flashing.
- Press “+” or “-” next to the TIME button to adjust the cooking duration, from 5 minutes to 2 hours.
- Staying in this  icon flashing mode, adjust the cooking temperature by the “+” and “-” buttons below the temperature display, from 40°C to 100°C.
- Display is now showing the chamber real time temperature.
- To start cooking, press  button and the button light will change to WHITE.  symbol shows up to indicate steam oven is now in cooking process.
- Cooking timer starts to count down after the oven heats up to the selected temperature. The steam oven only takes 4 – 5 minutes to heat up from 30°C to 100°C.
- In the final 3 mins cooking duration, timer will con down in seconds.
- When the cooking time has elapsed, the time display will turn to local time and buzzer will ring.
- The display temperature will gradually reduce according to real time chamber condition.
- Press  to turn the oven off. Alternatively the steam oven will automatically turn itself off after 30 minutes.

### **Shortcut Function**

- Press  to turn the oven on. Press  button to enter shortcut function and oven will start cooking at 100°C for 10 minutes.

### **Setting Preset Start Cooking Time**

A cooking duration must be set before the preset start timer can be scheduled.

- Follow the above cooking duration setting instructions mentioned above.
- Press TIME button again after setting cooking duration and temperature. At this time,  icon is flashing.
- Press “+” or “-” to preset the start cooking time.
- Staying in this  icon flashing mode, press  button to start the function, the button light will change to WHITE.
- Cooking will starts according to scheduled time and duration.

Note: Water will not pump to the element immediately on starting, so if the water reservoir is empty or low it may take up to 1 minute before the  beeps and flashes.

**Only in  or  flashing mode could the oven be turned on to start cooking.**

**WARNING:** Steam oven door surface temperature can go up to 55°C during the cooking process.

The steam oven will allow partial steam to escape when the cooking process nearly comes to an end.

When opening the oven door during the cooking cycle do so gradually and allow the steam to escape to avoid risk of scalding.



Do not let children play around with or near cooking appliances.

The fan motor will run for 15 minutes after cooking time finishes. Condensation may fall into the gutter under the oven door.

The steam oven will automatically shut off when the steam oven door is opened during operation and buzzer will ring. Close the door and press START/PAUSE to resume cooking.

If the steam oven is still hot, steam will be released when the door is opened. Please keep away from the appliance, until the steam vents completely. Be aware that hot water may spill out from the coagulation groove when the door is opened. Do not touch the steam and the surrounds of the steam oven, so as to avoid being scalded.

### **Water Shortage Alert**

- When the water reservoir level is low, the  symbol beside the temperature display will flash and buzzer will ring, press any button to cancel the buzzer, and the steam oven will stop heating.
- Add water according to adding water instruction, press the START button to continue cooking and the  symbol will cease to flash, START/PAUSE button will change from red to white, oven is now working.

Note: Water will not pump to the element immediately on starting, so if the water reservoir is empty or low it may take up to 1 minute before the  symbol ceases beeping and flashing.



## Recommended Cooking Time

Food	Temperature(° C)	Time* (minutes)
<b>Vegetables</b>		
Broccoli (small size)	100	5-6
Cauliflower	100	12-14
Cauliflower (small size)	100	6-8
Green Soya Bean	100	8-10
Peas	100	5
Potato (peeled & cut in half)	100	20-25
Potato (with skin)	100	30-35
Carrot (in pieces)	100	6-8
Asparagus	100	10-14
<b>Meat &amp; Sausage</b>		
Chicken (1kg)	100	25-30
Chicken in pieces	100	6-7
Sausage	90	5
Pork Rib	100	7-9
Minced meat	100	15
Pork	100	6-8
<b>Fish</b>		
Salmon Fillets	100	5-6
Flatfish Fillets	85	5-7
Carp Fillets	85	5-7
<b>Baked Food</b>		
Cheese Macaroni	100	25-35
Meat Pie	100	10-12
<b>Bean</b>		
Soaked Lentil	100	10-15
Dry Bean	100	22-25
Dry Lentil	100	20-22
<b>Rice &amp; Grain</b>		
Wheat	100	10
Porridge	100	20
Whole Grain	100	16-35
<b>Boil Egg</b>		
Just Cooked	100	5
Medium-Well Done	100	5-6
Well Done	100	8-10
<b>Fruits</b>		
Apple/Pear in Pieces	100	5
Cherry	100	5
Chinese Rhubarb	100	5

The above information is for reference only

The heating time\* should depend on the actual situation and individual preference.

\* Cooking time display will start to count down after the steam oven heats up to the selected temperature

## **Cleaning and Maintenance**

Caution: Prior to cleaning or maintenance, always disconnect the power supply.

Make sure that steamer cleaner is not used.

### **Water reservoir :**

Before using the steam oven for the first time, we suggest to flushing the built in water reservoir 3 times. Connect the appliance to power and turn on, push-open the water reservoir inlet to access to the water filling point and add water, keep the steam oven door opened, gently pull the water outlet on the left hand side of the door frame downwards, and the water will discharge from the water outlet, repeat this process 3 times to remove any unpleasant smell;  
Empty the built in water reservoir each time after use;

**WARNING:** Gently pull the water outlet downwards to drain the water reservoir. Use an appropriate vessel to collect the discharged water from the water reservoir. Please empty and flush the built in water reservoir after every use to avoid having coagulation or odors.

### **Side Seal :**

Use hot soapy water and a sponge and clean and dry the side seal of the steam oven door every time after use. **DO NOT USE CLEANING PRODUCTS.**  
Replace the door seal with a new one if it becomes torn or damaged.

### **Inner Part of Steam Oven :**

Clean the chamber of the steam oven after use with a soapy sponge or soft cloth to wipe off the residue.

Most cooking residue can be removed by cloth with soapy water or by using a neutral cleanser. In some areas where the water supply contains high levels of impurity, it will leave a white deposit in the chamber. Use a cloth wetted with vinegar to wipe off this deposit; followed by clean water, wipe and then dry the chamber.

Make sure there is no cleaner pasting on the side seal of the steam oven door.

### **Shelves and Trays :**

Wash and dry the shelves and trays after use.

### **Stainless Steel Panel & Casing :**

Use a soft non abrasive cloth with warm soapy water to the clean control panel, door panel and the casing of the steam oven. Dry the stainless steel surfaces with soft dry cloth. Allowing a stain to stay on the stainless steel surfaces for long periods may damage the stainless steel surface.

**Warning:** Do not use harsh chemicals or harsh cleaning agents around this area or use any abrasive material. Doing so may remove these indicator markings which will not be covered by warranty.

Use appropriate glass cleanser to clean the glass on the steam oven door.

It is suggested to use non scratched cleaning agents to clean the stainless steel surface by following the direction of grain.

### **Heating Element :**

The heating element may have a build up of scale after a period of time, use hot water with 5% citric acid cleanser to remove the scale from the heating element.

## **Warning:**



1. Ensure that the appliance is switched off before replacing the lamp to avoid the possibility of electrical shock.
2. Accessible parts may become hot during use. Young children should be kept away.
3. Do not use harsh abrasive cleaners or sharp metal scrapers to clean the oven door glass since they can scratch the surface, which may result in shattering of the glass.
4. Steam cleaner is not to be used.
5. Fixed wiring must be protected.
6. Means for disconnection must be incorporated in the fixed wiring in accordance with the wiring rules.
7. When it is in use the appliance becomes hot. Care should be taken to avoid touching heating elements inside the oven.
8. Surfaces of oven can get hot.
9. This product must not be disposed with the domestic waste. It has to be disposed at an authorised bin for recycling the appliances.
10. This appliance is not intended for use by person (including children) with reduced physical, sensory or mental capabilities or lack of experience and knowledge. Unless, they have been given supervision or instruction regarding the use of appliance by personnel who is responsible for their safety.
11. Clean the steam oven after it cools down; then dry it thoroughly. Make sure the steam oven interior is completely dry before closing the door.
12. Do not use any cleaning agents which contains soda, acid or chlorine; do not use cleaning sprays, harsh abrasive cleaners or sharp metal scrapers to clean the steam oven. Harsh or abrasive cleaners may scratch the surface.

## **Troubleshooting**

The maintenance and service must be carried by qualified service person. The manufacturer is not liable for any direct or indirect damage caused by unqualified service person or installer.

Problem : The steam oven will not function

Possible Causes & Solution :

- Turn the steam oven off and remove the plug from the power point.
- Check if the fuse has blown and replacement is required.
- Re-connect to the power and start the steam oven. If the oven still will not start, call the service representative or electrician.
- Only in  or  flashing mode could the oven be turned on to start cooking.

Problem : The steam oven fails to heat up after it starts:

Possible Causes & Solution :

- Check whether the steam oven door has been closed properly.
- Check there is adequate water in the water reservoir.
- Check whether the fuse on heating element has blown.

Problem : The steam oven takes too long to heat up:

Possible Causes & Solution :

- Check whether there is a thick layer of scale on the heating element and clean the heating element. If this fails to solve the problem, please contact the service representative.
- Check whether the door seal has been damaged. If so, call the service representative for replacement.

Problem : Symbol  appears on the display:

Possible Cause & Solution :

- Check whether there is enough water in the water reservoir.

## Disposal



This product must not be disposed together with the domestic waste. This product has to be disposed at an authorized place for recycling of electrical and electronic appliances. By collecting and recycling waste, you help save natural resources, and make sure the product is disposed in an environmental friendly and health way.

**DISPOSAL:** Do not dispose this product as unsorted municipal waste. Collection of such waste separately for special treatment is necessary.