

Black Glass Baffle Filter Rangehood 900mm — CH917BSL

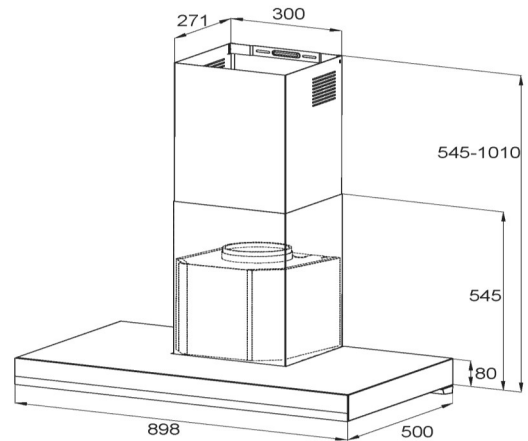

Product Specifications *

Finish	Stainless steel with black glass display
Dimensions	898 x 500mm
Power Source	10amp
Installation	Wall mounted
Ducting	Ducted or recirculating
Flue Dimension	150mm
Max Height	1010mm including body
Capacity	1000m ³ /hr
Motor	400W motor with stainless steel chassis
Noise Rating	<59dB
Speeds	4 speed concealed LED touch control
Filter	3 x Stainless steel baffle filters
Illumination	LED light bar
Options	Charcoal filters Remote control Interchangeable motor options
Warranty	3 years

*Specifications and product size may change without notice. Shinda International is not responsible for any errors or omissions.

All dimensions and images are for illustrative purposes and cut-outs should be based on physical product measurements.