

## Concealed Rangehood 900mm— CE928MP

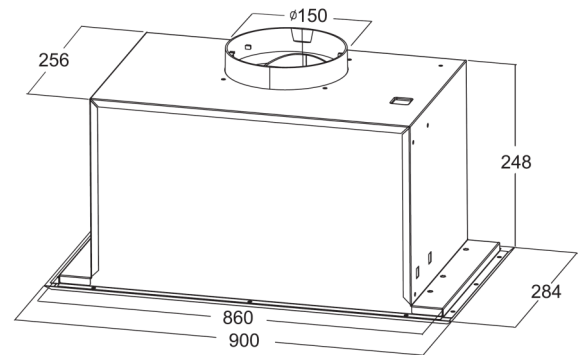

### Product Specification

Finish	Stainless steel
Dimensions	900(W) x 284mm(D) (product) 865(W) x 260mm(D) (cut out)
Power Source	10 amp
Installation	Undermount
Ducting	Ducted or Recirculating
Flue Diameter	150mm
Capacity	800m3/hr
Motor	290 watt motor
Noise Rating	<69dB
Speeds	3 speed
Filter	2 x Aluminium filter, removable and washable
Options	Charcoal Filter
Warranty	3 years