

## Concealed Rangehood 700mm – CE920HSS

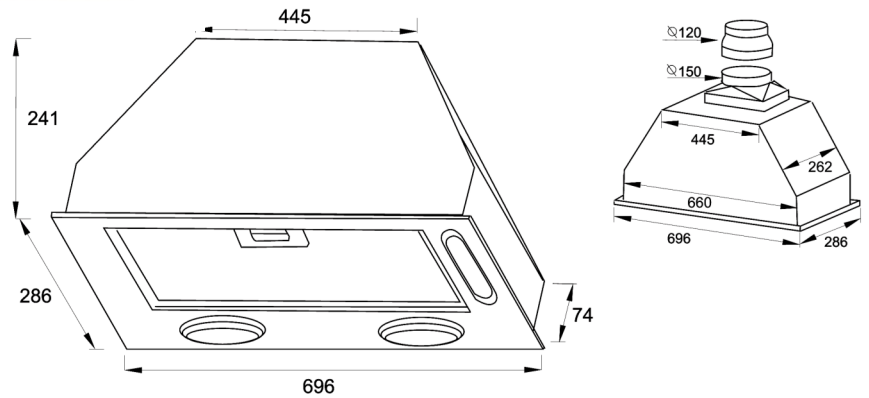

### Product Specification \*

Finish	Stainless Steel
Dimensions	696 x 286mm
Power Source	10amp
Installation	Undermount
Capacity	570m3/hr
Ducting	Ducted or Recirculating
Flue Diameter	150mm
Capacity	570m3/hr
Motor	250 watt motor
Noise Rating	<51dB
Speeds	3 speed mechanical controls
Filter	1 Aluminium filter, removable and washable
Illumination	2 x GU10 LED bulbs
Options	Charcoal filters
Warranty	3 years

\*Specifications and product size may change without notice. Shinda International is not responsible for any errors or omissions.

All dimensions and images are for illustrative purposes and cut-outs should be based on physical product measurements.