

Di LUSO

A P P L I A N C E S

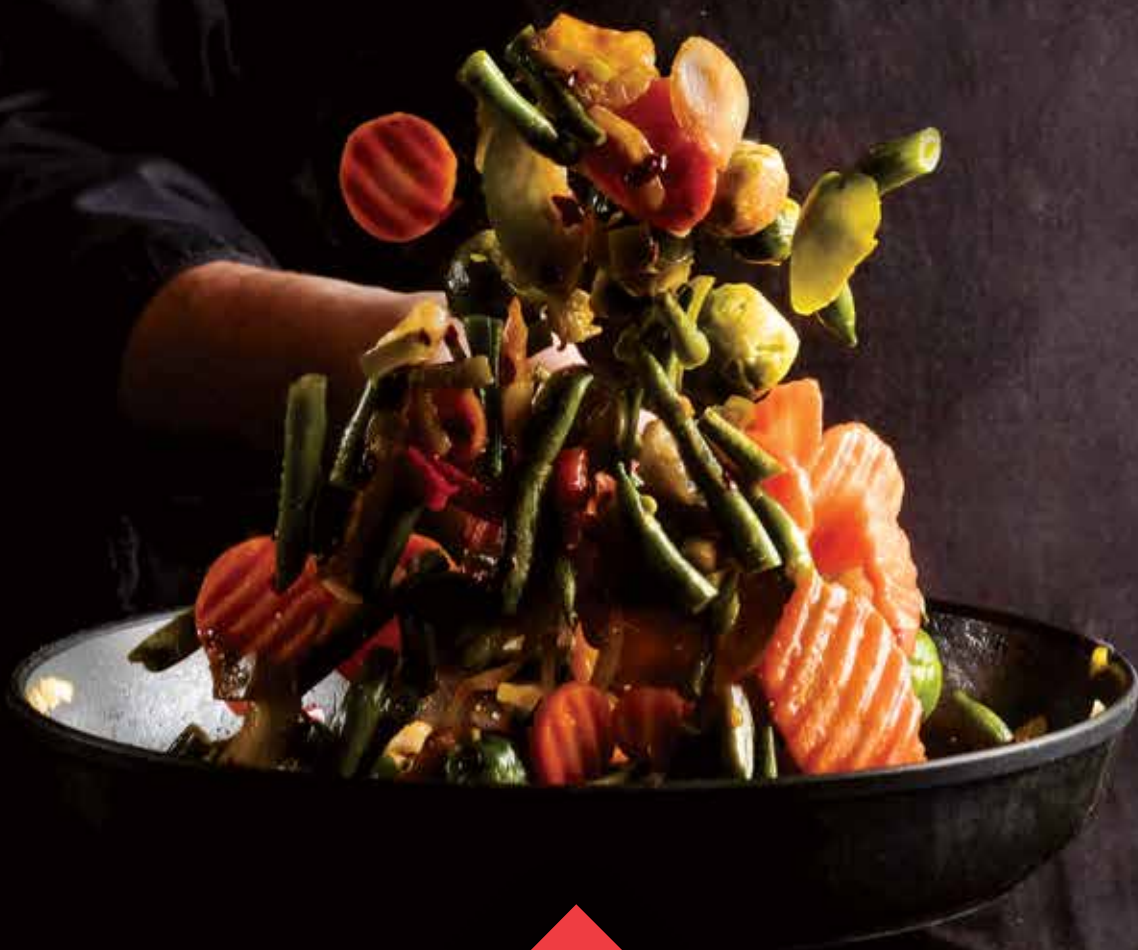

Kitchen
Collection



Contents

01 OUR STORY

02-09 OVENS

10-13 COOKTOPS

14-18 STEAM OVENS

19 MICROWAVE OVENS

19 WARMING DRAWERS

20-27 RANGEHOODS

28-29 DISHWASHERS

30-35 MEASUREMENTS





Turn your love for cooking

into a passion



EXPERIENCE THE DI LUSSO DIFFERENCE!

Di Lusso with the meaning "Of Luxury", presents to you a collection of opulent appliances that will turn your passion for cooking into a creation.

Di Lusso Appliances showcases the latest in kitchen technology and style. Our niche collection embodies premium quality with intuitive features to inspire your kitchen and your cooking.

WHY DI LUSSO APPLIANCES?

Di Lusso Appliances offers European style, value added features and designs, with you in mind.

Our collection includes built in ovens, freestanding cookers, designer steam ovens, gas and ceramic cooktops, warming drawers, stainless steel dishwashers and practical rangehoods. Everything a serious home cook would want.

OUR STORY

Di Lusso is a brand of Shinda International, who are renowned for reliability and superior customer service in the Australian market. Shinda International has been manufacturing and marketing for the Australian and worldwide markets since 1995.

Through strategic investments and joint ventures, Shinda International has control over its supply chain starting from manufacture through to the delivery and servicing of their products.

Our confidence is demonstrated by offering a **3 years manufacturer's warranty** on all appliances.



Ovens

Experience the
Difference



FINGERPRINT RESISTANT STAINLESS STEEL*

Keeps your oven exterior shiny and free of marks. Any stains can be removed with an easy wipe.



TRIPLE GLAZED DOORS

Triple glazed doors are an added safety feature as 3 layers of glass leaves the oven door cool to touch.

Di Lusso, giving you peace of mind when you have small children who are interested in "What's cooking?"



TRUE FAN FORCE

All Di Lusso ovens have a true fan force function even our most basic model. Fan force functionality, unlike fan assisted, has a circular heating element at the back of the oven, where the fan circulates heat evenly inside the cooking chamber, cooking your food evenly.

Di Lusso also does not consider the light as a function, so a 7 function Di Lusso oven has 7 cooking functions.



TELESCOPIC RAILS*

Telescopic rails allow the oven rack to extend right out, making it easier for you to baste your food, check on the cooking progress and remove the baking tray. Most **Di Lusso** ovens include two wire racks and a baking tray, giving you flexibility to cook on all different levels.

*featured in certain models only.

OVEN FUNCTIONS

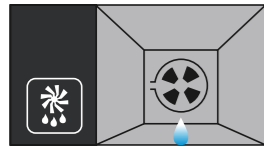

Defrost

The fan operates without the heating elements. Can be used to defrost frozen food. The required time for defrosting depends on the type and quantity of food, and the room temperature. Always check food packaging for instructions. (All models)

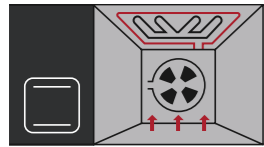

Conventional

The traditional way of cooking, using the bottom and top outer heating elements to provide heat from above and below. It is ideal for pastries and for slow cooking at a low temperature. Best positions are shelf levels 2 and 3. (7, 8 & 9 functions models)

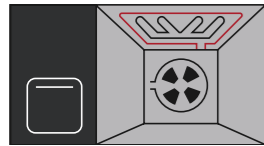

Top Heat

Top outer heating element radiates heat down directly to your food, giving your food a golden brown finish. Also suitable for gentle cooking and reheating meals. (9 function model)

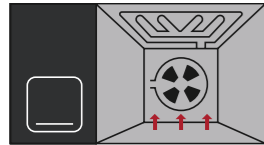

Bottom Heat

Operates the bottom heating element, for more focused heat and control. Use this function to achieve crispy bases in pies and pizzas. Also suitable for slow cooking or reheating meals. (8 & 9 functions models)

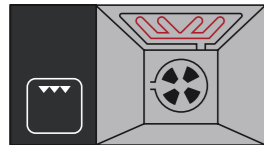

Half Grill

The inner top heating element operates. Provides direct heat to the top surface of the food. It is suitable for small portions of foods, e.g. toast. Keep oven door closed when in use. (7,8 & 9 functions model)

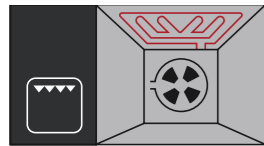

Full Grill

Both outer and inner part of the top heating element operates. It is more suitable for grilling larger portions of foods than the half grill function, e.g. sausages, steaks, fish. Keep oven door closed when in use. (4, 7 & 8 functions models)

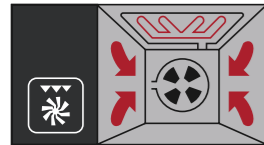

Half Grill + Fan

With fan assisted, the inner top heating element is able to give a very generous coverage of the grill tray from rear to front. Suitable for cooking small portions of food. (9 functions models)

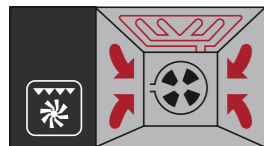

Full Grill + Fan

Both inner and outer part of the top heating element operates with fan assistance. The fan disperses the radiant heat from the elements. Suitable for browning food, whilst keeping it moist. The door must be closed whilst grilling. (4, 7 & 8 functions models)

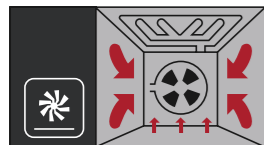

Bottom Heating + Fan

Bottom heating element operates with fan assistance. It is perfect for dishes with a pastry base and filling, such as custard tarts. It is also suitable for heating precooked foods, or to sterilize preserving jars. (7 & 9 functions models)

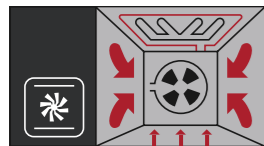

Top + Bottom Heating Element + Fan

Provides even heating with the top and bottom element and the fan operating simultaneously. Food will be browned on top and heated from the bottom. (8 functions model)

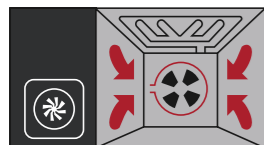

Fan Forced

The circular heating element and the fan comes into operation. Heat is distributed evenly to all levels. Several dishes can be cooked on different shelves. Fan forced mode is ideal for baking, cooking large serves of food and cooking different dishes together. (All Di Lusso models)

BUILT-IN OVENS

ELECTRIC OVEN - 600MM 4 FUNCTION

OV604MS



FINISH	• Exterior	• Fingerprint resistant Stainless Steel
	• Interior	• Triple glazed door
DIMENSIONS	• 595(W) x 595(H) x 575mm(D)	
	• 70L	
POWER SOURCE	• Electricity 10amp plug in	
FUNCTIONS		
STD ACCESSORIES	<ul style="list-style-type: none"> • 1 x wire rack • 1 x baking tray • 1 x grill insert 	
SHELVES	• 10 levels	
FEATURES	• 4 cooking functions with mechanical timer	
	• 120min cooking timer	
	• Oven ventilation system	
	• Fingerprint resistant stainless steel	
	• Removable cool touch glass door	
WARRANTY	• 3 years	

ELECTRIC OVEN - 600MM 8 FUNCTION

OV608MS



FINISH	• Exterior	• Fingerprint resistant Stainless Steel
	• Interior	• Triple glazed door
DIMENSIONS	• 595(W) x 595(H) x 575mm(D)	
	• 70L	
POWER SOURCE	• Electricity 15amp plug in	
FUNCTIONS		
STD ACCESSORIES	<ul style="list-style-type: none"> • 2 x wire racks • 1 x baking tray • 1 x grill insert 	
SHELVES	• 10 levels	
FEATURES	• 8 cooking functions	
	• LED fully programmable timer	
	• Digital clock	
	• Fingerprint resistant stainless steel	
	• Removable cool touch glass door	
WARRANTY	• 3 years	

BUILT-IN OVENS

ELECTRIC OVEN - 600MM 75L SS 7 FUNCTION OV607SSL



FINISH	• Exterior	• Fingerprint resistant Stainless Steel • Triple glazed cool touch door
	• Interior	• High grade easy clean enamel
DIMENSIONS	• 595(W) x 595(H) x 565mm(D)	
CAPACITY	• 75L	
POWER SOURCE	• Electricity 15amp plug in	
FUNCTIONS		
STD ACCESSORIES	<ul style="list-style-type: none"> • 2 x telescopic rails • 2 x telescopic racks • 1 x baking tray • 1 x grill insert • 1 x tray handle 	
SHELVES	• 4 levels	
FEATURES	<ul style="list-style-type: none"> • 7 cooking functions • 2 telescopic rails & racks • LED fully programmable timer • Digital clock • Removable cool touch glass door • Cavity cooling system 	
WARRANTY	• 3 years	

BUILT-IN OVENS

ELECTRIC OVEN - 900MM SS 8 FUNCTION OV908DSL



FINISH	• Exterior	• Fingerprint resistant Stainless Steel • Triple glazed cool touch door
	• Interior	• High grade easy clean enamel
DIMENSIONS	• 895(W) x 475(H) x 568mm(D)	
CAPACITY	• 100L	
POWER SOURCE	• Electricity 15amp plug in	
FUNCTIONS		
STD ACCESSORIES	<ul style="list-style-type: none"> • 1 x telescopic rail • 1 x telescopic rack • 1 x baking tray • 1 x grill insert • 1 x tray handle • 1 x multiple skewer rotisserie 	
SHELVES	• 4 levels	
FEATURES	<ul style="list-style-type: none"> • 8 cooking functions • Rotisserie • Programmable digital timer (up to 23hrs 59mins) • Digital clock • Digital thermostat • Removable cool touch glass door 	
WARRANTY	• 3 years	

ELECTRIC OVEN - 600MM 75L BLACK GLASS 7 FUNCTION OV607BBL



FINISH	• Exterior	• Black Glass • Triple glazed cool touch door
	• Interior	• High grade easy clean enamel
DIMENSIONS	• 595(W) x 595(H) x 565mm(D)	
CAPACITY	• 75L	
POWER SOURCE	• Electricity 15amp plug in	
FUNCTIONS		
STD ACCESSORIES	<ul style="list-style-type: none"> • 2 x telescopic rails • 2 x telescopic racks • 1 x baking tray • 1 x grill insert • 1 x tray handle 	
SHELVES	• 4 levels	
FEATURES	<ul style="list-style-type: none"> • 7 cooking functions • 2 telescopic rails & racks • LED fully programmable timer • Digital clock • Removable cool touch glass door • Cavity cooling system 	
WARRANTY	• 3 years	

ELECTRIC OVEN - 900MM BLACK GLASS 11 FUNCTION OV911TBL



FINISH	• Exterior	• Black Glass • Triple glazed cool touch door
	• Interior	• High grade easy clean enamel
DIMENSIONS	• 895(W) x 475(H) x 568mm(D)	
CAPACITY	• 100L	
POWER SOURCE	• Electricity 15amp plug in	
FUNCTIONS		
STD ACCESSORIES	<ul style="list-style-type: none"> • 1 x telescopic rail • 1 x telescopic rack • 1 x baking tray • 1 x grill insert • 1 x tray handle • 1 x multiple skewer rotisserie 	
SHELVES	• 4 levels	
FEATURES	<ul style="list-style-type: none"> • 11 cooking functions • Full digital touch controls • Rotisserie • Programmable digital timer (up to 23hrs 59mins) • Digital thermostat • Removable cool touch triple glazed door 	
WARRANTY	• 3 years	

FREESTANDING COOKERS

FREESTANDING DUAL FUEL COOKER - 600MM FS607G4DS



HOB	<ul style="list-style-type: none"> 4 burner gas cooktop Cast iron trivets 	<ul style="list-style-type: none"> Italian Sabaf burners with flame failure devices Under knob ignition
	BURNERS	MJ/HR
	<ul style="list-style-type: none"> Wok Medium x 2 Auxiliary 	<ul style="list-style-type: none"> 12.5 6.7 4.0
OVEN	<ul style="list-style-type: none"> 58L, 7 function oven <ul style="list-style-type: none"> High grade easy clean enamel LED programmable timer Triple glazed removable cool touch door Cavity cooling system 	
DIMENSIONS	603(W) x 600 (D) x 900 (H)	
POWER SOURCE	<ul style="list-style-type: none"> Cooktop - Natural gas Oven - Electric 	
STD ACCESSORIES	<ul style="list-style-type: none"> 2 x wire racks 1 x baking tray 1 x grill insert 	<ul style="list-style-type: none"> 1 x rack tong Pull out storage drawer
OPTIONS	<ul style="list-style-type: none"> LPG converter Stainless steel kickboard 	
SHELVES	4 positions	
WARRANTY	3 years	

FREESTANDING COOKERS

FREESTANDING DUAL FUEL COOKER - 900MM PRESTIGE FS909G5SSD



HOB	<ul style="list-style-type: none"> 5 burner gas cooktop with side wok burner Cast iron trivets Triple ring wok burner Italian Sabaf burners 	<ul style="list-style-type: none"> Flame Failure Device on all burners Stainless steel coloured knobs Under knob ignition
	BURNERS	MJ/HR
	<ul style="list-style-type: none"> Wok Large Medium x 2 Auxiliary 	<ul style="list-style-type: none"> 12.5 11.5 6.7 4.0
OVEN	<ul style="list-style-type: none"> 98L, 9 function oven <ul style="list-style-type: none"> High grade easy clean enamel LED programmable timer Triple glazed removable cool touch door Cavity cooling system 	
DIMENSIONS	903(W) x 605 (D) x 948 (H)	
POWER SOURCE	<ul style="list-style-type: none"> Cooktop - Natural gas Oven - Electric 	
STD ACCESSORIES	<ul style="list-style-type: none"> 4 telescopic rails 2 x telescopic rack 1 x telescopic baking tray 	<ul style="list-style-type: none"> 1 x grill insert 2 x rack tong Push in pop out storage drawer
OPTIONS	<ul style="list-style-type: none"> LPG converter 	
SHELVES	4 positions	
WARRANTY	3 years	

FREESTANDING DUAL FUEL COOKER - 900MM DESIGNER FS909G5CSD



HOB	<ul style="list-style-type: none"> 5 burner gas cooktop with central wok burner Cast iron trivets Triple ring wok burner 	<ul style="list-style-type: none"> Italian Sabaf burners Flame Failure Device on all burners Under knob ignition
	BURNERS	MJ/HR
	<ul style="list-style-type: none"> Wok Large Medium x 2 Auxiliary 	<ul style="list-style-type: none"> 12.5 11.5 6.7 4.0
OVEN	<ul style="list-style-type: none"> 98L, 9 function oven <ul style="list-style-type: none"> High grade easy clean enamel LED programmable timer Triple glazed removable cool touch door Cavity cooling system 	
DIMENSIONS	903(W) x 605 (D) x 948 (H)	
POWER SOURCE	<ul style="list-style-type: none"> Cooktop - Natural gas Oven - Electric 	
STD ACCESSORIES	<ul style="list-style-type: none"> 4 telescopic rails 2 x telescopic rack 1 x telescopic baking tray 	<ul style="list-style-type: none"> 1 x grill insert 2 x rack tong Push in pop out storage drawer
OPTIONS	<ul style="list-style-type: none"> LPG converter 	
SHELVES	4 positions	
WARRANTY	3 years	



You'll be **D**iligent in the high standards of our designer ovens.

C O O K T O P S



Cooktops

Experience the
Difference

Bevelled edged Schott glass
Side triple ring wok burners
Italian Sabaf burners

GAS COOKTOP - 600MM SS ENAMEL TRIVETS

GC604MSFE



FINISH	• Stainless Steel	
DIMENSIONS	• 590(W) x 500mm(D)	
POWER SOURCE	• Natural Gas / LPG	
TRIVETS	• Black enameled steel	
BURNERS	• Triple ring wok burner • Semi-rapid burner (2) • Auxiliary burner	• 3.6kW • 1.75kW • 1.0kW
CONTROLS	• Side controls	
FEATURES	• Flame failure devices • Italian SABAF burners • Wok trivet	• Automatic under knob ignition • All trivets, burner caps and knobs are removable and dishwasher safe
OPTIONS	• Cast iron trivets	
WARRANTY	• 3 years	

GAS COOKTOP - 600MM SS CAST IRON TRIVETS

GC604MSFC

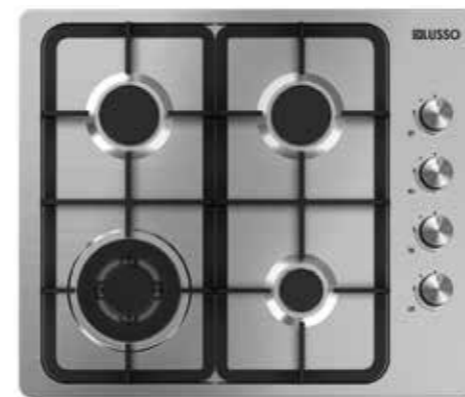

FINISH	• Stainless Steel	
DIMENSIONS	• 590(W) x 500mm(D)	
POWER SOURCE	• Natural Gas / LPG	
TRIVETS	• Cast iron trivets	
BURNERS	• Triple ring wok burner • Semi-rapid burner (2) • Auxiliary burner	• 3.6kW • 1.75kW • 1.0kW
CONTROLS	• Side controls	
FEATURES	• Flame failure devices • Italian SABAF burners • Cast iron trivets • Wok trivet	• Automatic under knob ignition • All trivets, burner caps and knobs are removable and dishwasher safe
WARRANTY	• 3 years	

GAS COOKTOP - 600MM BLACK GLASS

GC604MBFC



FINISH	• Black glass	
DIMENSIONS	• 600(W) x 510mm(D)	
POWER SOURCE	• Natural Gas / LPG	
TRIVETS	• Cast iron trivets	
BURNERS	• Triple ring wok burner • Semi-rapid burner (2) • Auxiliary burner	• 3.6kW • 1.75kW • 1.0kW
CONTROLS	• Side controls	
FEATURES	• Flame failure devices • Italian SABAF burners • Cast iron trivets • Wok trivet	• Automatic under knob ignition • All trivets, burner caps and knobs are removable and dishwasher safe
WARRANTY	• 3 years	

C O O K T O P S

GAS COOKTOP - 900MM STAINLESS STEEL GC905MSFC



FINISH	• Stainless Steel	
DIMENSIONS	• 860(W) x 510mm(D)	
POWER SOURCE	• Natural Gas / LPG	
TRIVETS	• Cast iron trivets	
BURNERS	<ul style="list-style-type: none"> • Triple ring wok burner • Rapid burner • Semi-rapid burner (2) • Auxiliary burner 	<ul style="list-style-type: none"> • 3.6kW • 3.0kW • 1.75kW • 1.0kW
CONTROLS	• Front knob controls	
FEATURES	<ul style="list-style-type: none"> • Flame failure devices • Italian SABAF burners • Side triple ring wok burner • Wok trivet included • Cast iron trivets 	<ul style="list-style-type: none"> • Automatic under knob ignition • All trivets, burner caps and knobs are removable and dishwasher safe
WARRANTY	• 3 years	

GAS COOKTOP - 900MM BLACK GLASS GC905MBFCC



FINISH	• Black glass	
DIMENSIONS	• 860(W) x 525mm(D)	
POWER SOURCE	• Natural Gas / LPG	
TRIVETS	• Cast iron trivets	
BURNERS	<ul style="list-style-type: none"> • Triple ring wok burner • Rapid burner • Semi-rapid burner (2) • Auxiliary burner 	<ul style="list-style-type: none"> • 3.6kW • 3.0kW • 1.75kW • 1.0kW
CONTROLS	• Front knob controls	
FEATURES	<ul style="list-style-type: none"> • Flame failure devices • Italian SABAF burners • Side triple ring wok burner • Wok trivet included • Cast iron trivets 	<ul style="list-style-type: none"> • Automatic under knob ignition • All trivets, burner caps and knobs are removable and dishwasher safe
WARRANTY	• 3 years	

CERAMIC COOKTOP - 600MM KNOB CONTROL CC604MK



FINISH	• Schott black glass	
DIMENSIONS	• 590(W) x 520mm(D)	
POWER SOURCE	• 30amp hard wired	
ZONES	<ul style="list-style-type: none"> • 2 x 1200watt • 2 x 1800watt 	
CONTROLS	<ul style="list-style-type: none"> • Knob Control • 12 variable heating levels 	
FEATURES	<ul style="list-style-type: none"> • Power indicator • Residual heat Indicators • Overheating protection 	
WARRANTY	• 3 years	

C O O K T O P S

CERAMIC COOKTOP - 600MM TOUCH CONTROL CC604MBT



FINISH	• Schott bevelled edged black glass	
DIMENSIONS	• 590(W) x 520mm(D)	
POWER SOURCE	• 30amp hard wired	
ZONES	• 2 x 1200watt	• 2 x 1800watt
CONTROLS	• Sensor touch	
FEATURES	<ul style="list-style-type: none"> • Auto off timer • Residual heat Indicators • Overheating protection 	<ul style="list-style-type: none"> • Child lock • Bevelled edged Schott glass for a flush finish
WARRANTY	• 3 years	

CERAMIC COOKTOP - 900MM TOUCH CONTROL CC905MBT



FINISH	• Schott bevelled edged black glass	
DIMENSIONS	• 900(W) x 520mm(D)	
POWER SOURCE	• 35amp hard wired	
ZONES	<ul style="list-style-type: none"> • 2 x 1200watt • 1 x 1800watt 	<ul style="list-style-type: none"> • 1 x 1100/2000 watt expandable zone • 1 x 1000/2200 watt expandable zone
CONTROLS	• Sensor touch	• 9 variable heating levels
FEATURES	<ul style="list-style-type: none"> • Auto off timer • Residual heat Indicators • Overheating protection 	<ul style="list-style-type: none"> • Child lock • Bevelled edged Schott glass for a flush finish
WARRANTY	• 3 years	

INDUCTION COOKTOP - 600MM FLEXI ZONE IC603GKB



FINISH	• EuroKera bevelled edged black glass	
DIMENSIONS	• 590(W) x 520mm(D)	
POWER SOURCE	• 30amp hard wired	
ZONES	<ul style="list-style-type: none"> • 1 x 2000/3000W booster • 1 x 1500/2000W booster • 1 x 2000/2600W booster 	<ul style="list-style-type: none"> • 1 x 1500/2000W booster • Flexi - 3000/3600W booster
CONTROLS	<ul style="list-style-type: none"> • Sensor touch • Slider controls 	• 9 variable heating levels
FEATURES	<ul style="list-style-type: none"> • Flexi Zone • Power booster function • Auto off timer • Pause function • Cookware detection 	<ul style="list-style-type: none"> • Residual heat Indicators • Overheating protection • Child lock • Bevelled edged EuroKera glass for a flush finish
WARRANTY	• 3 years	

Steam Ovens

LOCK IN THE NUTRIENTS WITH STEAM COOKING

Steam offers a healthier way of cooking. Nutrients are not lost, food is moist and the steam oven is ideal for those who prefer not to use a microwave.

Di Lusso combi ovens and steam ovens have one of the largest capacities in the market. You can cook on several levels at a time and our combi ovens give you the benefits of steaming and baking in the one oven.

The advantage of steam cooking is that food smells are not transferred, so you can steam fish, vegetables and rice together without it all smelling like fish. A three course meal can be cooked together.

Our water reservoir is built into the steam oven, giving you a larger cooking chamber. The reservoir is easily topped up via the patented push and pop out spout. The reservoir can be easily topped up during cooking, a warning bell will ring advising you to top up with water. This can be all done without interruption to the cooking process.

All Di Lusso steam ovens come with a stainless steel rack and a perforated and solid steaming tray, giving you options to cook on all levels.

There are both built in and table top models available.

Di Lusso -
designing with
you in mind.

COMBI STEAM OVENS

BUILT IN COMBI STEAM OVEN - SS

CSO45SBI



FINISH	• Exterior	• Finger print resistant Stainless Steel
	• Interior	• Full Stainless Steel • Triple Glazed Door
DIMENSIONS	• 597(W) x 454(H) x 480mm(D)	
CAPACITY	• 45L	
POWER SOURCE	• 15amp plug in	
STD ACCESSORIES	<ul style="list-style-type: none"> • 1 x stainless steel rack • 1 x stainless steel perforated tray • 1 x stainless steel solid tray • 1 x water pitcher 	
LEVELS	• 3 levels	
FEATURES	<ul style="list-style-type: none"> • Steam, Fan Forced, Top element Baking and Grill functions • Programmable steam combi functions • Digital touch LCD controls • Water reservoir can be topped up during use • Soft opening water filling mechanism • Warning alarm when reservoir is full or near empty • Auto shut off when oven door is opened • Child lock 	
WARRANTY	• 3 years	

BUILT IN COMBI STEAM OVEN - BLACK GLASS

CSO45BBI



FINISH	• Exterior	• Black Glass
	• Interior	• Full Stainless Steel • Triple Glazed Door
DIMENSIONS	• 597(W) x 454(H) x 480mm(D)	
CAPACITY	• 45L	
POWER SOURCE	• 15amp plug in	
STD ACCESSORIES	<ul style="list-style-type: none"> • 1 x stainless steel rack • 1 x stainless steel perforated tray • 1 x stainless steel solid tray • 1 x water pitcher 	
LEVELS	• 3 levels	
FEATURES	<ul style="list-style-type: none"> • Steam, Fan Forced, Top element Baking and Grill functions • Programmable steam combi functions • Digital touch LCD controls • Water reservoir can be topped up during use • Soft opening water filling mechanism • Warning alarm when reservoir is full or near empty • Auto shut off when oven door is opened • Child lock 	
WARRANTY	• 3 years	

STEAM OVENS

FREESTANDING COMBI STEAM OVEN

FINISH	• Exterior options	<ul style="list-style-type: none"> • Silver and Black • Black • Red
	• Interior	<ul style="list-style-type: none"> • Full Stainless Steel • Triple Glazed Door
DIMENSIONS	• 490(W) x 415(H) x 380mm(D)	
CAPACITY	• 28L	
POWER SOURCE	• Electricity 10amp plug in	
STD ACCESSORIES	<ul style="list-style-type: none"> • 1 x stainless steel perforated tray • 1 x stainless steel solid tray • 1 x element guard • 1 x water pitcher 	
LEVELS	• 3 levels	
FEATURES	<ul style="list-style-type: none"> • Steam, High Temperature Steam, Steam Assist, Convection and Grill functions • Programmable steam combi functions • Table top design • Digital touch LCD controls • Top opening water reservoir • Water reservoir can be refilled during use • Warning alarm when reservoir is full or near empty • Auto shut off when oven door is opened • Child lock 	
WARRANTY	• 3 years	

Steaming - a **D**ifferent way to cook.



CSO28SBFS - SILVER



CSO28ABFS - BLACK



CSO28RBFS - RED

STEAM OVENS

BUILT IN STEAM OVEN - STAINLESS STEEL

SO60SBBI



FINISH	• Exterior	• Finger print resistant Stainless Steel
	• Interior	• Full Stainless Steel
DIMENSIONS	• 597(W) x 395(H) x 460mm(D)	
CAPACITY	• 33L	
POWER SOURCE	• Electricity 10amp plug in	
STD ACCESSORIES	<ul style="list-style-type: none"> • 1 x stainless steel rack • 1 x stainless steel perforated tray • 1 x stainless steel solid tray • 1 x water pitcher 	
LEVELS	• 3 levels	
FEATURES	<ul style="list-style-type: none"> • Extra large oven capacity • Digital touch LED controls • Water reservoir can be topped up during use • Patented built-in water reservoir and filling mechanism • Warning alarm when reservoir is full or near empty • Water reservoir drains effortlessly with a touch of a button • Auto shut off when oven door is opened 	
WARRANTY	• 3 years	

BUILT IN STEAM OVEN - BLACK GLASS

SO60BBBI



FINISH	• Exterior	• Full Black Glass
	• Interior	• Full Stainless Steel
DIMENSIONS	• 597(W) x 395(H) x 460mm(D)	
CAPACITY	• 33L	
POWER SOURCE	• Electricity 10amp plug in	
STD ACCESSORIES	<ul style="list-style-type: none"> • 1 x stainless steel rack • 1 x stainless steel perforated tray • 1 x stainless steel solid tray • 1 x water pitcher 	
LEVELS	• 3 levels	
FEATURES	<ul style="list-style-type: none"> • Extra large oven capacity • Digital touch LED controls • Water reservoir can be topped up during use • Patented built-in water reservoir and filling mechanism • Warning alarm when reservoir is full or near empty • Water reservoir drains effortlessly with a touch of a button • Over heating protection system • Auto shut off when oven door is opened 	
WARRANTY	• 3 years	

STEAM OVENS

FREESTANDING STEAM OVEN - BLACK GLASS SO633BBFS



FINISH	• Exterior	• Full Black Glass
	• Interior	• Full Stainless Steel
DIMENSIONS	• 539(W) x 393(H) x 459mm(D)	
CAPACITY	• 33L	
POWER SOURCE	• Electricity 10amp plug in	
STD ACCESSORIES	<ul style="list-style-type: none"> • 1 x stainless steel racks • 1 x stainless steel perforated tray • 1 x stainless steel solid tray • 1 x water pitcher 	
LEVELS	• 3 levels	
FEATURES	<ul style="list-style-type: none"> • Tabletop plug in design - able to fit into most microwave cabinets • Extra large oven capacity • Digital touch LED controls • Water reservoir can be topped up during use • Patented built-in water reservoir and filling mechanism • Warning alarm when reservoir is full or near empty • Water reservoir drains automatically via flip out spout • Over heating protection system • Auto shut off when oven door is opened 	
WARRANTY	• 3 years	

FREESTANDING STEAM OVEN - WHITE GLASS SO633WWFS



FINISH	• Exterior	• Full White Glass
	• Interior	• Full Stainless Steel
DIMENSIONS	• 539(W) x 393(H) x 459mm(D)	
CAPACITY	• 33L	
POWER SOURCE	• Electricity 10amp plug in	
STD ACCESSORIES	<ul style="list-style-type: none"> • 1 x stainless steel racks • 1 x stainless steel perforated tray • 1 x stainless steel solid tray • 1 x water pitcher 	
LEVELS	• 3 levels	
FEATURES	<ul style="list-style-type: none"> • Tabletop plug in design - able to fit into most microwave cabinets • Extra large oven capacity • Digital touch LED controls • Water reservoir can be topped up during use • Patented built-in water reservoir and filling mechanism • Warning alarm when reservoir is full or near empty • Water reservoir drains automatically via flip out spout • Over heating protection system • Auto shut off when oven door is opened 	
WARRANTY	• 3 years	

MICROWAVE OVENS

BUILT IN MICROWAVE WITH GRILL MOV28S2M



FINISH	• Stainless Steel
DIMENSIONS	• 595(W) x 388(H) x 440mm(D)
CAPACITY	• 28L
POWER SOURCE	• Electricity 10amp plug in
CONTROLS	• Digital and knob control
FUNCTIONS	<ul style="list-style-type: none"> • 900W Microwave • 1000W Grill power • 5 Power levels • 10 Preset menu options
FEATURES	<ul style="list-style-type: none"> • True built in microwave • Glass turn-table • Metal grill rack • Programmable multistage cooking • Programmable timer • Auto weight defrost • Child Lock
WARRANTY	• 3 years

WARMING DRAWERS

STAINLESS STEEL WARMING DRAWER WD200SSS



FINISH	• Stainless Steel
DIMENSIONS	• 597(W) x 197(H) x 530mm(D)
CAPACITY	• 6 place settings, 20kg max load
STD ACCESSORIES	• Antislip Mat
FEATURES	<ul style="list-style-type: none"> • Warms plates, cups, saucers up to 20kg load • Can be used to keep food warm or proof dough • Timer control (up to 120mins) • Adjustable temperature settings (to 75°C) • Removable anti slip mat • Finger print resistant stainless steel
WARRANTY	• 3 years

BLACK GLASS WARMING DRAWER WD200BBS



FINISH	• Black Glass
DIMENSIONS	• 597(W) x 197(H) x 530mm(D)
CAPACITY	• 6 place settings, 20kg max load
STD ACCESSORIES	• Antislip Mat
FEATURES	<ul style="list-style-type: none"> • Warms plates, cups, saucers up to 20kg load • Can be used to keep food warm or proof dough • Timer control (up to 120mins) • Adjustable temperature settings (to 75°C) • Removable anti slip mat
WARRANTY	• 3 years



Rangehoods

Experience the
Difference

R A N G E H O O D S

CONCEALED RANGEHOOD - 520MM

CE620HSS



FINISH	• Stainless Steel
DIMENSIONS	• 520(W) x 286mm(D)
POWER SOURCE	• 10amp
INSTALLATION	• Undermount
DUCTING	• Ducted or recirculating
FLUE Ø	• 150mm
CAPACITY	• 570m ³ /hr
MOTOR	• 250 watt motor
NOISE RATING	• <51db
SPEEDS	• 3 speed mechanical controls
FILTER	• 1 x Aluminium filters, removable and washable
ILLUMINATION	• 2 x GU10 LED bulbs
OPTIONS	• Charcoal filters
WARRANTY	• 3 years

CONCEALED RANGEHOOD - 700MM

CE920HSS



FINISH	• Stainless Steel
DIMENSIONS	• 696(W) x 286mm(D)
POWER SOURCE	• 10amp
INSTALLATION	• Undermount
DUCTING	• Ducted or recirculating
FLUE Ø	• 150mm
CAPACITY	• 570m ³ /hr
MOTOR	• 250 watt motor
NOISE RATING	• <51db
SPEEDS	• 3 speed mechanical controls
FILTER	• 1 x Aluminium filters, removable and washable
ILLUMINATION	• 2 x GU10 LED bulbs
OPTIONS	• Charcoal filters
WARRANTY	• 3 years

R A N G E H O O D S

TELESCOPIC RANGEHOOD - 600MM

TH602MSL



FINISH	• Stainless Steel
DIMENSIONS	• 595(W) x 305mm(D) (441mm fully extended)
	• 43mm fascia
POWER SOURCE	• 10amp
INSTALLATION	• Built in, integrated fascia
DUCTING	• Ducted only
FLUE Ø	• 120mm
CAPACITY	• 220m ³ /hr
MOTOR	• 125W single motor
NOISE RATING	• < 63db
SPEEDS	• 2 speed mechanical controls
FILTER	• 2 x Aluminium filters, removable and washable
ILLUMINATION	• 2 X LED lights
WARRANTY	• 3 years

TELESCOPIC RANGEHOOD - 600MM

TH604MSL



FINISH	• Stainless Steel
DIMENSIONS	• 595(W) x 300mm(D) (434mm fully extended)
	• 80mm fascia (recirculating mode)
	• 43mm fascia (ducted mode)
POWER SOURCE	• 10amp
INSTALLATION	• Built in, integrated fascia
DUCTING	• Ducted or Recirculating
FLUE Ø	• 120mm
CAPACITY	• 400m ³ /hr
MOTOR	• 100W twin motors
NOISE RATING	• < 71db
SPEEDS	• 2 speed mechanical controls
FILTER	• 2 x Aluminium filters, removable and washable
ILLUMINATION	• 2 X LED lights
OPTIONS	• Charcoal filters
WARRANTY	• 3 years

R A N G E H O O D S

TELESCOPIC RANGEHOOD - 900MM

TH902S



FINISH	• Stainless Steel
DIMENSIONS	• 898(W) x 280mm(D) (435mm fully extended)
	• 70mm fascia
POWER SOURCE	• 10amp
INSTALLATION	• Built in, integrated fascia
DUCTING	• Ducted or recirculating
FLUE Ø	• 125mm
CAPACITY	• 280m ³ /hr
MOTOR	• 85W twin motors
NOISE RATING	• <59db
SPEEDS	• 2 speed mechanical
FILTER	• 2 x Aluminium filters, removable and washable
ILLUMINATION	• 2 x 40 watt incandescent lights
OPTIONS	• Charcoal filters
WARRANTY	• 3 years

NEW SERIES

Di Lusso has upgraded their rangehoods with new motors, lighting and options for locating the motor away from the rangehood. See our  SERIES range for more details.

Experience the **Di**fference.



R A N G E H O O D S

SS CANOPY RANGEHOOD - 600MM

CH601SS



FINISH	• Stainless Steel
DIMENSIONS	• 600(W) x 515mm(D)
POWER SOURCE	• 10amp
INSTALLATION	• Wall mounted
DUCTING	• Ducted or recirculating
FLUE Ø	• 150mm
MAX HEIGHT	• 975mm including body
CAPACITY	• 750m ³ /hr
MOTOR	• 260W motor with stainless steel chassis
NOISE RATING	• <59db
SPEEDS	• 3 speed soft touch controls
FILTER	• 2 x Aluminium filters, removable and washable
ILLUMINATION	• 2 x LED lights
OPTIONS	• Charcoal filters • Interchangeable motor options
WARRANTY	• 3 years

R A N G E H O O D S

GLASS CANOPY RANGEHOOD - 600MM

CH607GSS



FINISH	• Stainless Steel
DIMENSIONS	• 600(W) x 460mm(D)
POWER SOURCE	• 10amp
INSTALLATION	• Wall mounted
DUCTING	• Ducted or recirculating
FLUE Ø	• 150mm
MAX HEIGHT	• 980mm including body
CAPACITY	• 750m ³ /hr
MOTOR	• 260W motor with stainless steel chassis
NOISE RATING	• <59db
SPEEDS	• 3 speed soft touch controls
FILTER	• 2 x Aluminium filters, removable and washable
ILLUMINATION	• 2 x LED lights
OPTIONS	• Charcoal filters • Interchangeable motor options
WARRANTY	• 3 years

SS CANOPY RANGEHOOD - 900MM

CH901SS



FINISH	• Stainless Steel
DIMENSIONS	• 900(W) x 515mm(D)
POWER SOURCE	• 10amp
INSTALLATION	• Wall mounted
DUCTING	• Ducted or recirculating
FLUE Ø	• 150mm
MAX HEIGHT	• 975mm including body
CAPACITY	• 750m ³ /hr
MOTOR	• 260W motor with stainless steel chassis
NOISE RATING	• <59db
SPEEDS	• 3 speed soft touch controls
FILTER	• 3 x Aluminium filters, removable and washable
ILLUMINATION	• 2 x LED lights
OPTIONS	• Charcoal filters • Interchangeable motor options
WARRANTY	• 3 years

GLASS CANOPY RANGEHOOD - 900MM

CH907GSS



FINISH	• Stainless Steel
DIMENSIONS	• 900(W) x 460mm(D)
POWER SOURCE	• 10amp
INSTALLATION	• Wall mounted
DUCTING	• Ducted or recirculating
FLUE Ø	• 150mm
MAX HEIGHT	• 980mm including body
CAPACITY	• 750m ³ /hr
MOTOR	• 260W motor with stainless steel chassis
NOISE RATING	• <59db
SPEEDS	• 3 speed soft touch controls
FILTER	• 2 x Aluminium filters, removable and washable
ILLUMINATION	• 2 x LED lights
OPTIONS	• Charcoal filters • Interchangeable motor options
WARRANTY	• 3 years

R A N G E H O O D S

T STYLE CANOPY RANGEHOOD - 600MM CH624SL



FINISH	• Stainless Steel with Black Glass display
DIMENSIONS	• 598(W) x 500mm(D)
POWER SOURCE	• 10amp
INSTALLATION	• Wall mounted
DUCTING	• Ducted or recirculating
FLUE Ø	• 150mm
MAX HEIGHT	• 995mm including body
CAPACITY	• 1000m3/hr
MOTOR	• 400W motor with stainless steel chassis
NOISE RATING	• <59db
SPEEDS	• 4 speed concealed LED touch control
FILTER	• 2 x Aluminium filters, removable and washable
ILLUMINATION	• LED light bar
OPTIONS	• Charcoal filters • Remote Control • Interchangeable motor options
WARRANTY	• 3 years

R A N G E H O O D S

CURVED GLASS CANOPY RANGEHOOD - 900MM CH903GSTL



FINISH	• Stainless Steel with tempered glass
DIMENSIONS	• 898(W) x 460mm(D)
POWER SOURCE	• 10amp
INSTALLATION	• Wall mounted
DUCTING	• Ducted or recirculating
FLUE Ø	• 150mm
MAX HEIGHT	• 981mm including body
CAPACITY	• 1000m3/hr
MOTOR	• 400W motor with stainless steel chassis
NOISE RATING	• <59db
SPEEDS	• 4 speed concealed LED touch control
FILTER	• 2 x Aluminium filters, removable and washable
ILLUMINATION	• LED light bar
OPTIONS	• Charcoal filters • Remote Control • Interchangeable motor options
WARRANTY	• 3 years

T STYLE CANOPY RANGEHOOD - 900MM CH924SL



FINISH	• Stainless Steel with Black Glass display
DIMENSIONS	• 898(W) x 500mm(D)
POWER SOURCE	• 10amp
INSTALLATION	• Wall mounted
DUCTING	• Ducted or recirculating
FLUE Ø	• 150mm
MAX HEIGHT	• 995mm including body
CAPACITY	• 1000m3/hr
MOTOR	• 400W motor with stainless steel chassis
NOISE RATING	• <59db
SPEEDS	• 4 speed concealed LED touch control
FILTER	• 3 x Aluminium filters, removable and washable
ILLUMINATION	• LED light bar
OPTIONS	• Charcoal filters • Remote Control • Interchangeable motor options
WARRANTY	• 3 years

BLACK GLASS BAFFLE FILTER RANGEHOOD - 900MM CH917BSL



FINISH	• Stainless Steel with Black Glass display
DIMENSIONS	• 898(W) x 500mm(D)
POWER SOURCE	• 10amp
INSTALLATION	• Wall mounted
DUCTING	• Ducted or recirculating
FLUE Ø	• 150mm
MAX HEIGHT	• 1010mm including body
CAPACITY	• 1000m3/hr
MOTOR	• 400W motor with stainless steel chassis
NOISE RATING	• <59db
SPEEDS	• 4 speed concealed LED touch control
FILTER	• 3 x Stainless Steel Baffle Filters
ILLUMINATION	• LED light bar
OPTIONS	• Charcoal filters • Remote Control • Interchangeable motor options
WARRANTY	• 3 years

DISH WASHERS

FREESTANDING DISHWASHER - 450MM 9 PLACE SETTINGS

DW45DGS



FINISH	• Stainless Steel
DIMENSIONS	• 448(W) x 600(D) x 845mm(H)
WELS WATER EFFICIENCY	• 4 stars
WELS WATER CONSUMPTION	• 9.4L
ENERGY RATING	• 3 stars
NOISE LEVEL	• 49dB
CONTROLS	• Push button control with LED display
FUNCTIONS	• 6 washing programs
CAPACITY	• 9 place settings
FEATURES	<ul style="list-style-type: none"> • Space saving • Dry+ option • LED display • Delay start • Child lock • Aquasafe flood protection • Removable top cover
WARRANTY	• 3 years

DISH WASHERS

FREESTANDING DISHWASHER - 600MM 14 PLACE SETTINGS

DW355DGS



FINISH	• Stainless Steel
DIMENSIONS	• 600(W) x 600(D) x 845mm(H)
WELS WATER EFFICIENCY	• 4 stars
WELS WATER CONSUMPTION	• 13.7L
ENERGY RATING	• 3 stars
NOISE LEVEL	• 49dB
CONTROLS	• Electronic touch with LED display
FUNCTIONS	• 6 washing programs
CAPACITY	• 14 place settings
FEATURES	<ul style="list-style-type: none"> • Dry+ option • Third level cutlery drawer • Concealed heating element • Foldable lower racks • Height adjustable upper basket • Aquasafe flood protection • Removable top cover • Delay start • Child lock
WARRANTY	• 3 years

FREESTANDING DISHWASHER - 600MM 12 PLACE SETTINGS

DW260GS



FINISH	• Stainless Steel
DIMENSIONS	• 600(W) x 600(D) x 845mm(H)
WELS WATER EFFICIENCY	• 4 stars
WELS WATER CONSUMPTION	• 11.8L
ENERGY RATING	• 3 stars
NOISE LEVEL	• 52dB
CONTROLS	• Electronic press controls
FUNCTIONS	• 6 washing programs
CAPACITY	• 12 place settings
FEATURES	<ul style="list-style-type: none"> • Dry+ option • Cutlery basket • Concealed heating element • Delay start • Full stainless steel door and display panel • Child lock
WARRANTY	• 3 years

FULLY INTEGRATED DISHWASHER - 600MM 14 PLACE SETTINGS

DW360FI



FINISH	• Stainless Steel
DIMENSIONS	• 598(W) x 550(D) x 845mm(H)
WELS WATER EFFICIENCY	• 4.5 stars
WELS WATER CONSUMPTION	• 12L
ENERGY RATING	• 3.5 stars
NOISE LEVEL	• 49dB
CONTROLS	• Push button controls with LED display
FUNCTIONS	• 8 washing programs
CAPACITY	• 14 place settings
FEATURES	<ul style="list-style-type: none"> • Turbo drying • Half load option • Concealed heating element • Foldable lower racks • Height adjustable upper basket • Third level cutlery drawer • Aquasafe flood protection • Delay start
OPTIONS	• Door panel with handle
WARRANTY	• 3 years

FS607G4DS

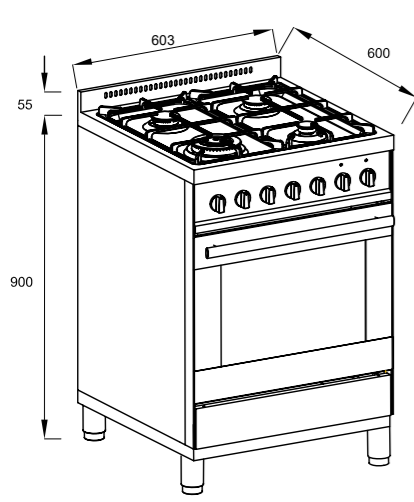

FS909G5CSD

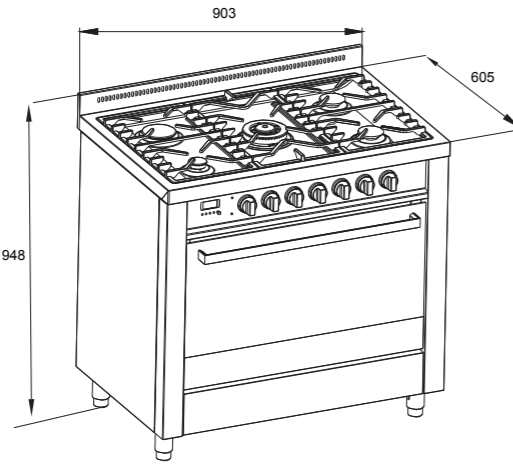

FS909G5SSD

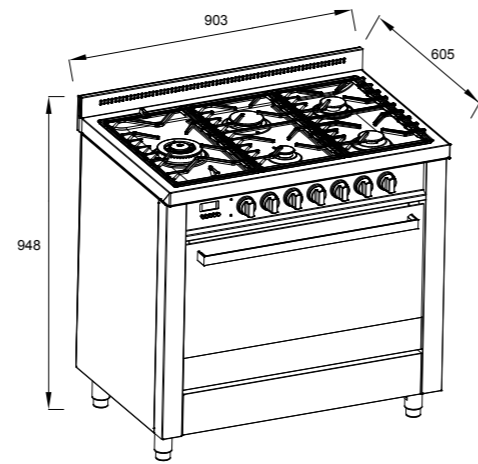

CSO45SBI, CSO45BBI

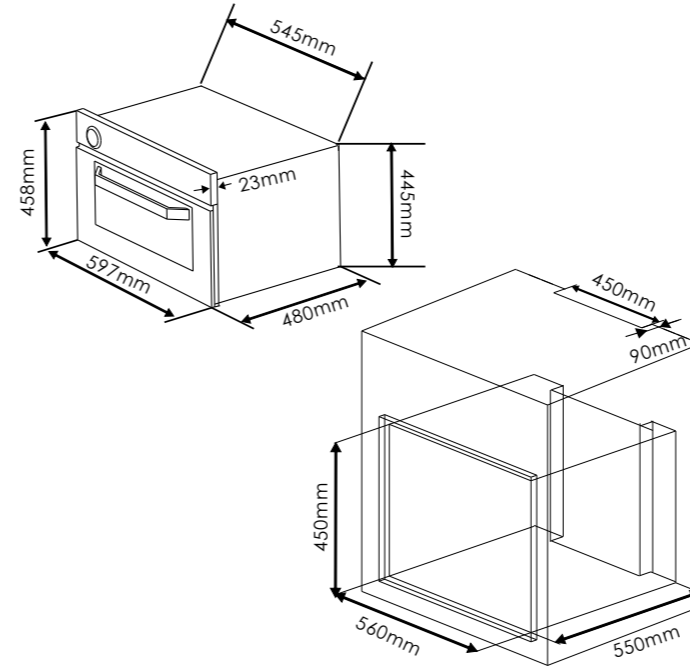

SO633BBFS, SO633WWFS

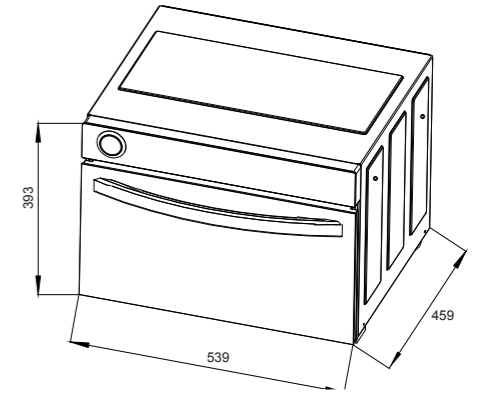

SO60SBBI, SO60BBBI

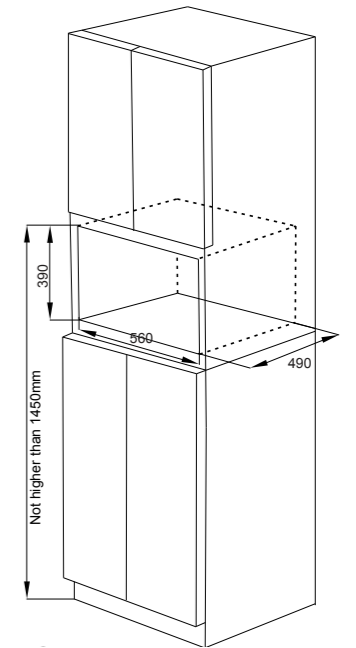

OV908DSL, OV911TBL

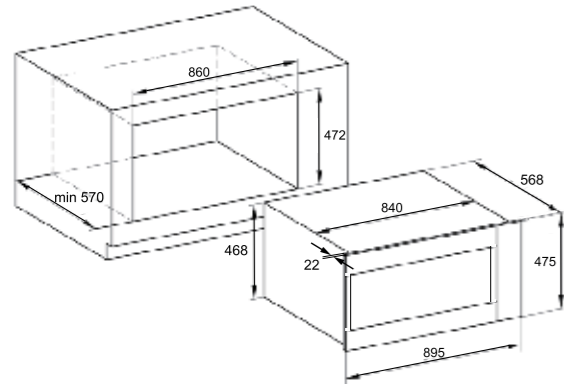

OV604MS, OV608MS

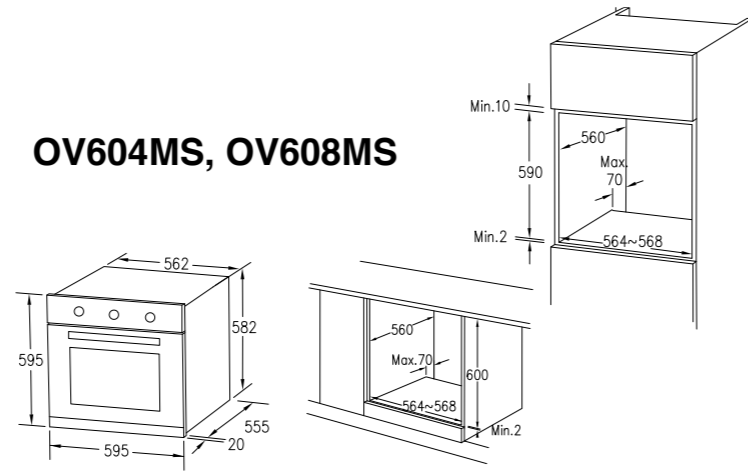

CSO28SBFS, CSO28ABFS, CSO28RBFS

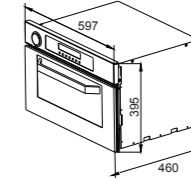
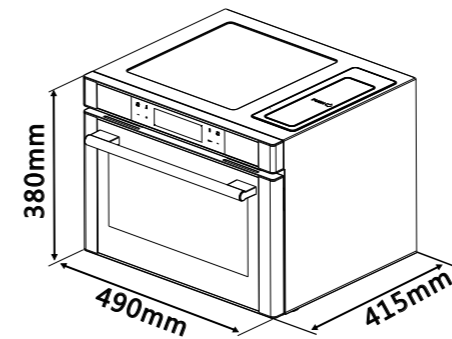

OV607BBL, OV607SSL

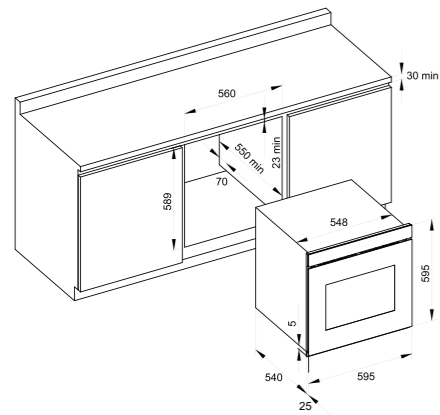

MOV28S2M

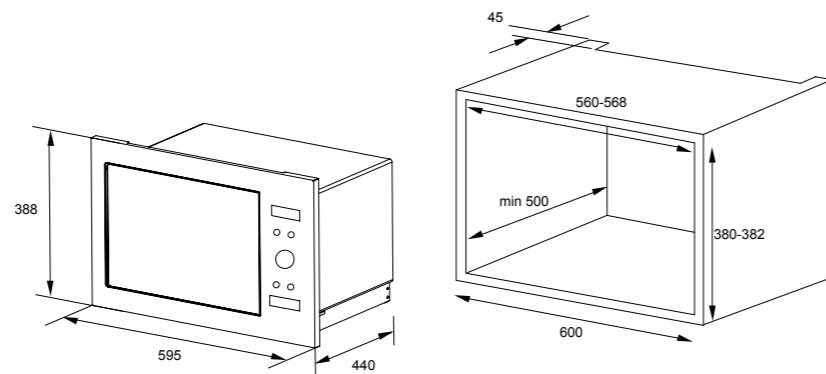

WD200SSS, WD200BBS

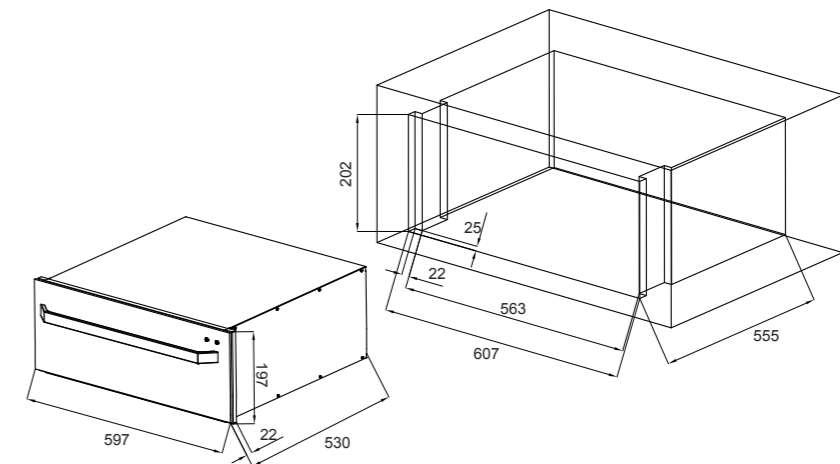

COOKTOPS

DISHWASHERS

GC604MSFE, GC604MSFC

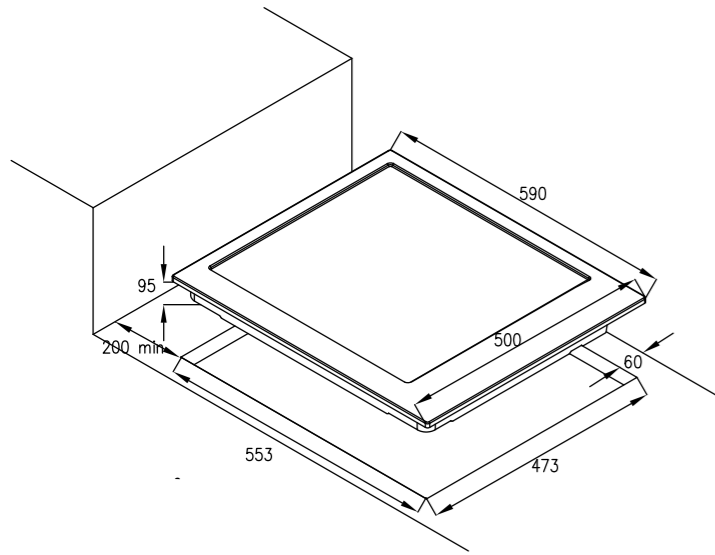

GC604MBFC

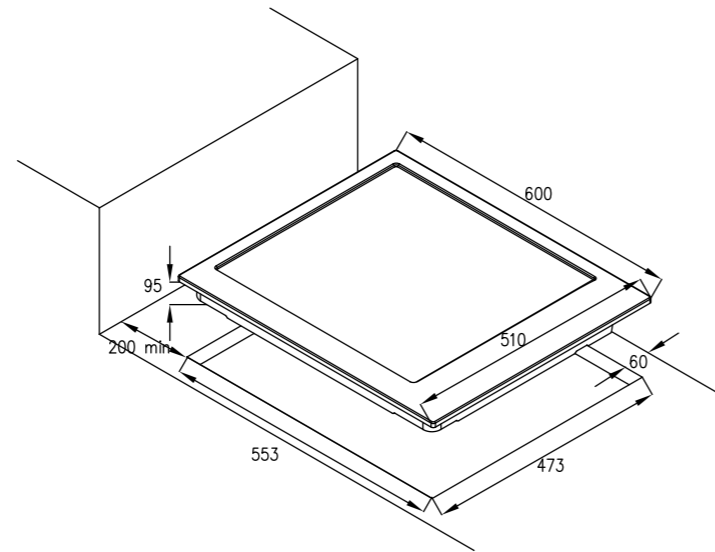

IC603GKB

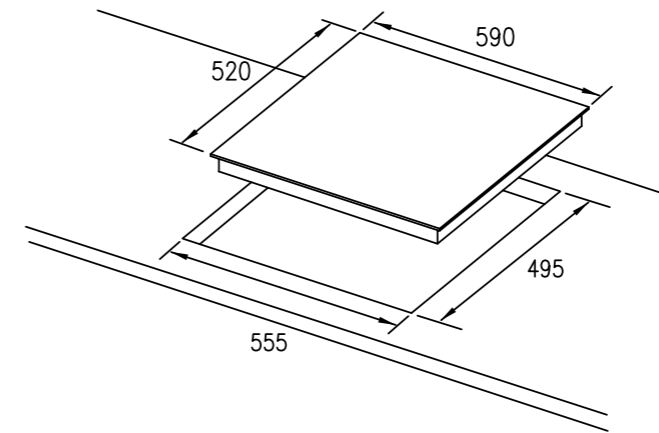

DW260GS , DW355DGS

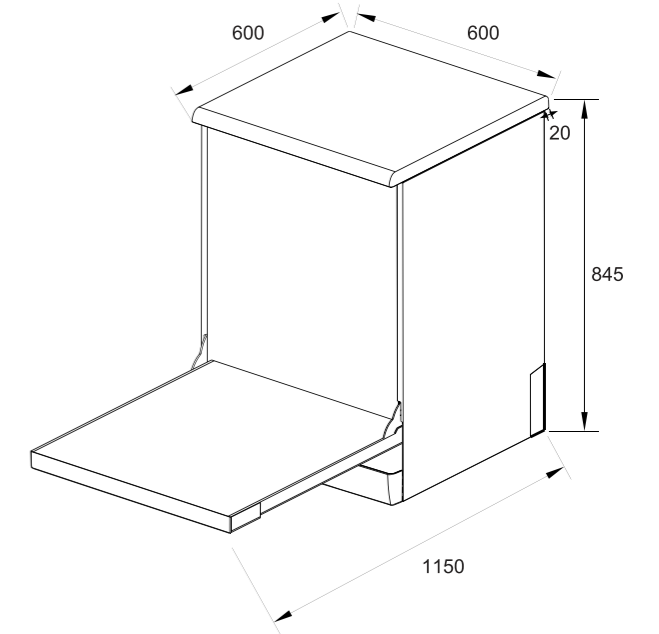

GC905MSFC

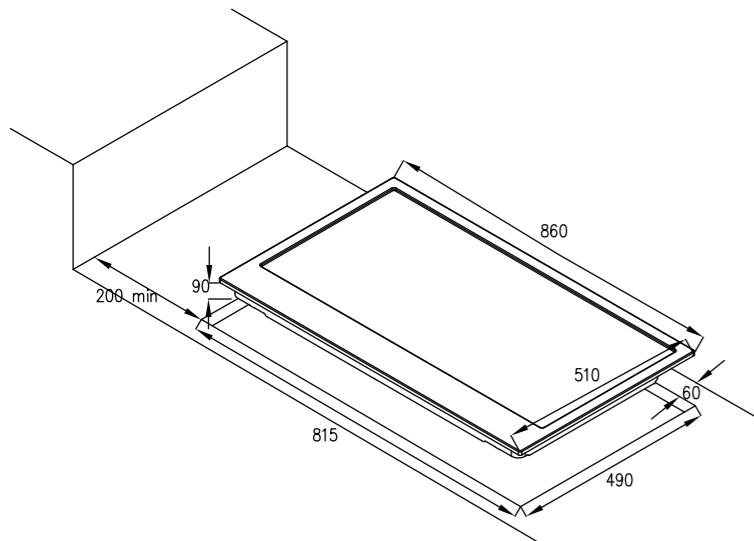

GC905MBFCC

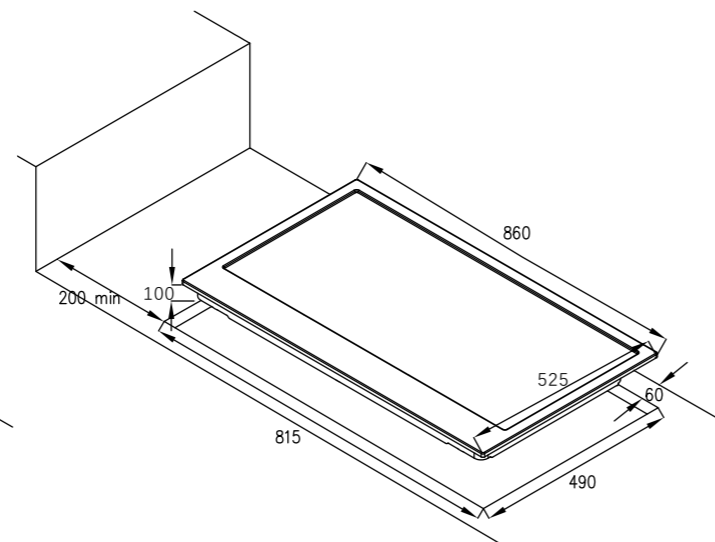

DW45DGS

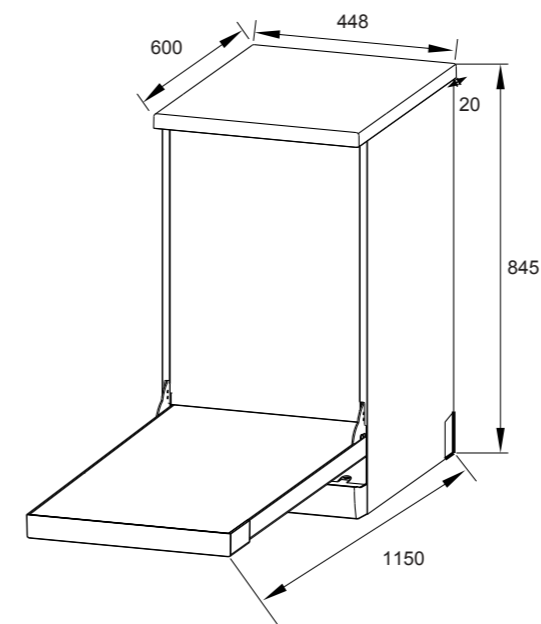

DW360FI

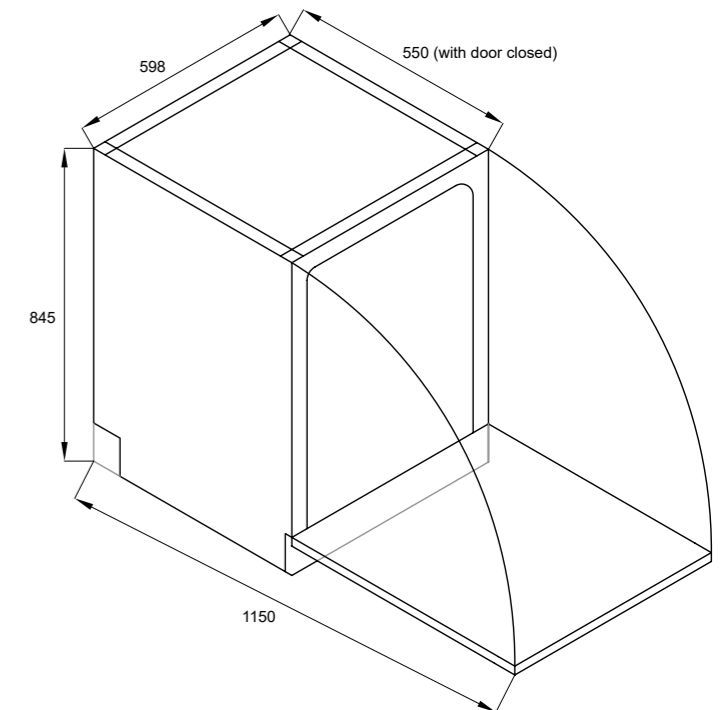

CC604MK, CC604MBT

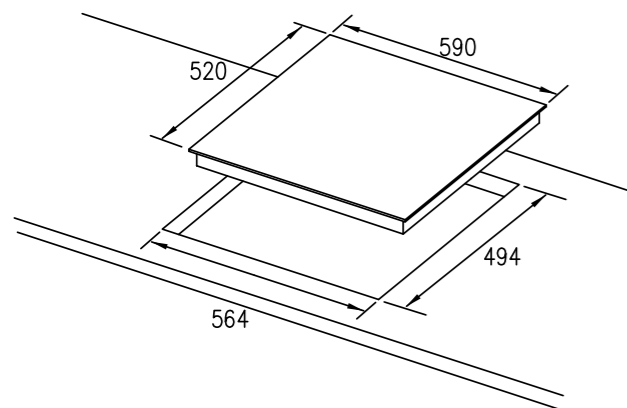

CC905MBT

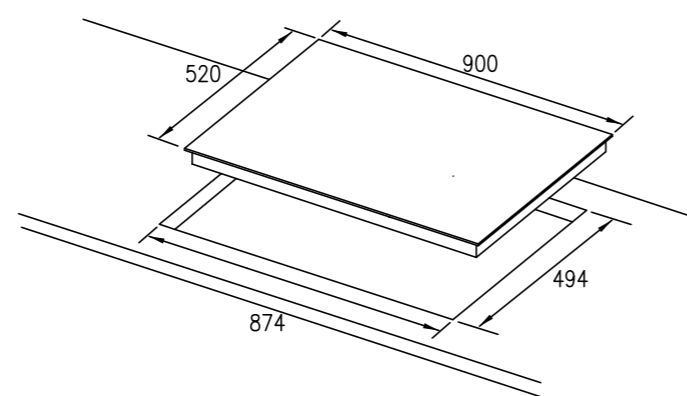

RANGEHOODS

CE620HSS

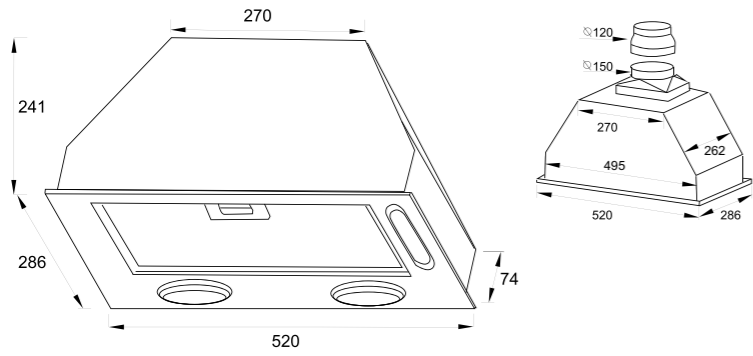

CE920HSS

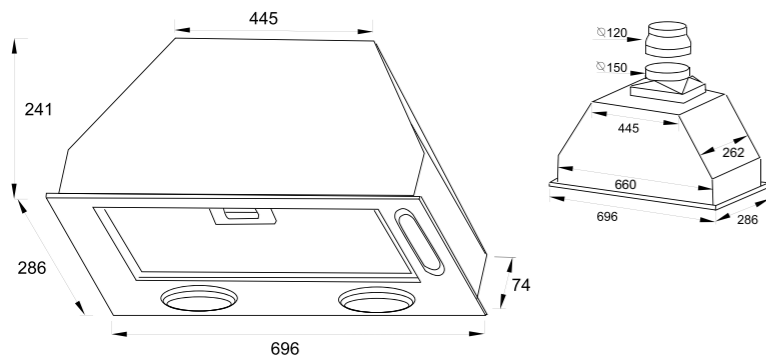

TH602MSL

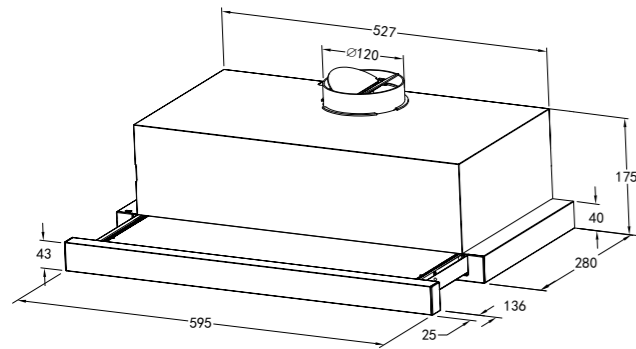

TH604MSL

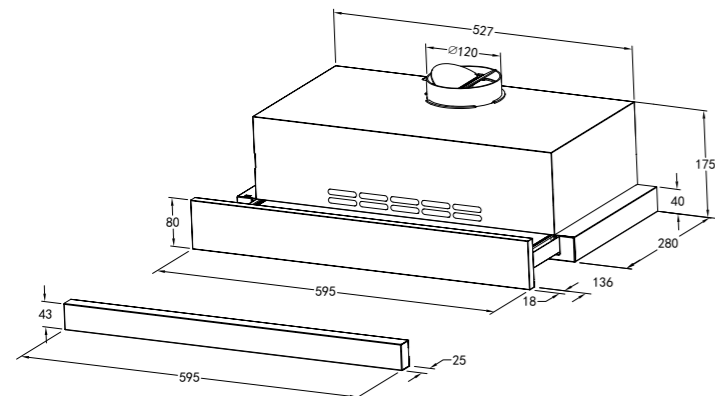

TH902S

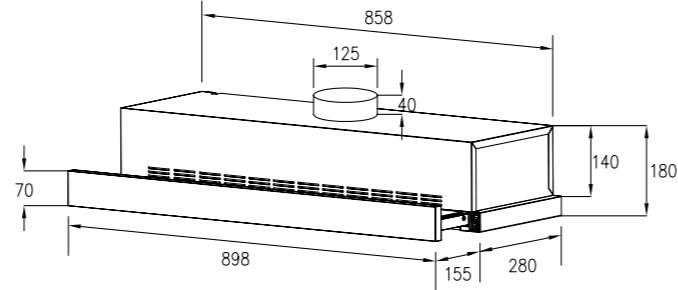

CH601SS

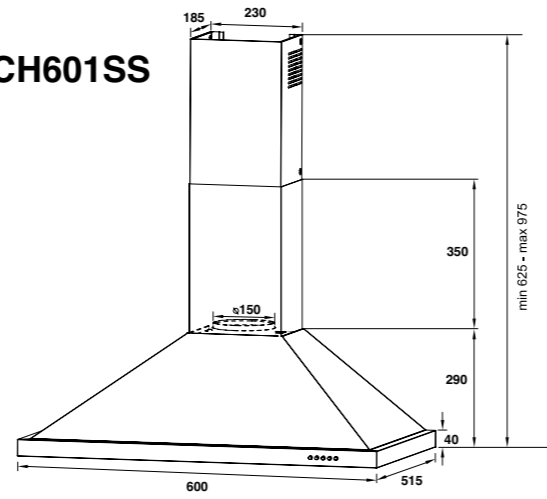

CH901SS

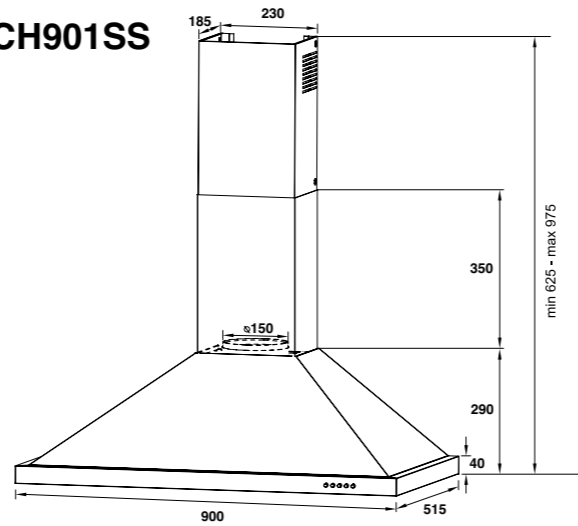

CH607GSS

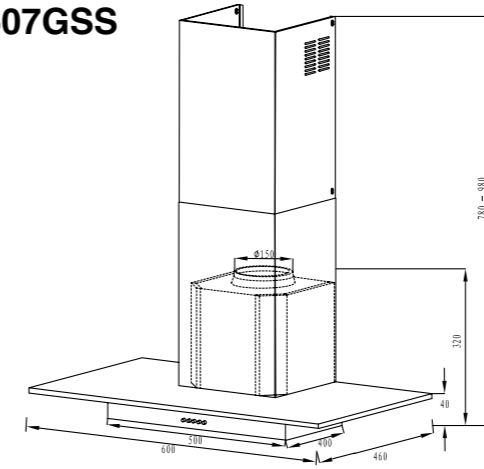

CH907GSS

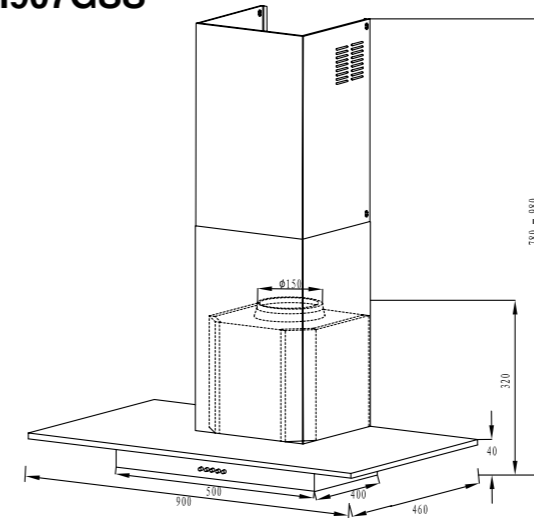

CH624SL

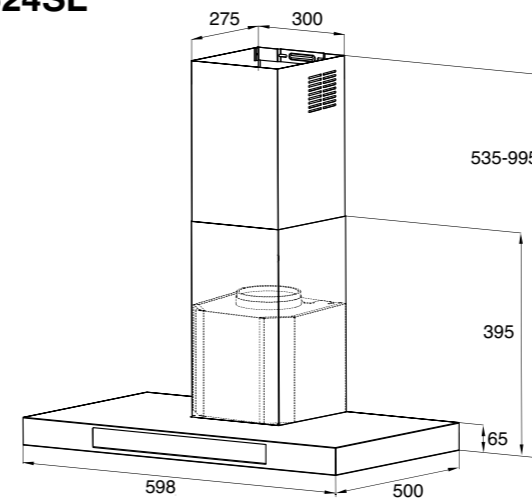

CH924SL

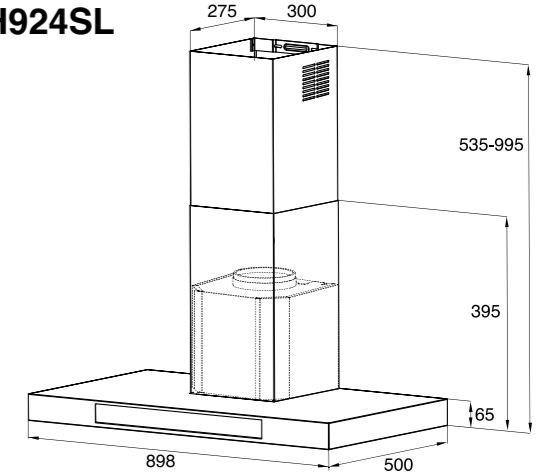

CH903GSTL

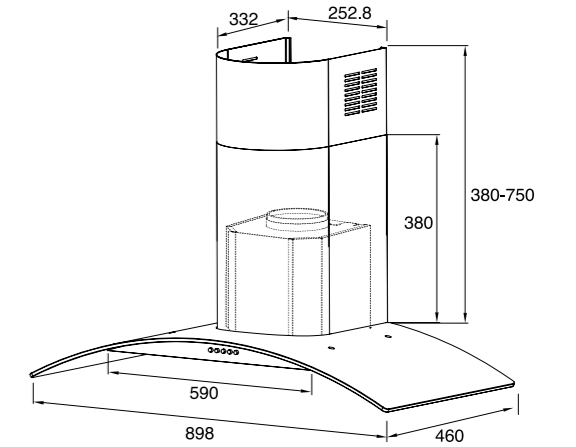

CH917BSL

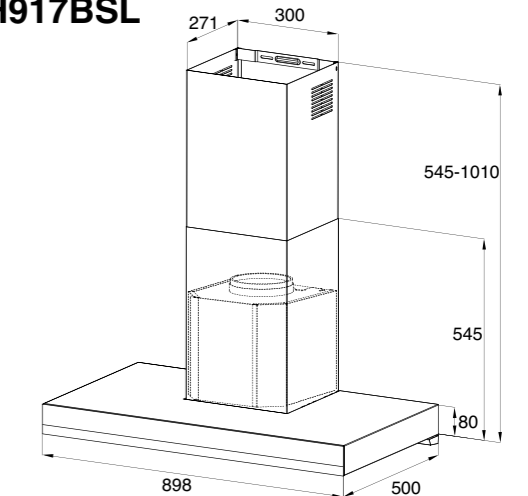

RANGEHOODS



Di LUSO
A P P L I A N C E S

SHINDA INTERNATIONAL PTY LTD

Unit 7, 9 Mavis Street, Revesby

NSW 2212 Australia

P 1300 358 770 | P 02 9773 7388 | F 02 9773 7399

W www.dilussoappliances.com.au | www.suprema.com.au

suprema™