

iTouch Dimmer



Touch Dimmer can control DC 12V/24V directly driving LED lighting products, such as LED cabinet light, LED rigid bar and LED strip.

Features

- Adopts capacitance touch technique
- Work as an On/Off switch and dimmer
- Memory function, remember the last scene
- Surface mount
- Ultra low profile and slick design
- Handle big loads up to 144W capability
- 2 years warranty



Specification

Model No.	Input Voltage	Output Power	IP Rating	Installation Method	Max Current	Working Temperature
TS01-6A	12V DC	72W	IP20 (Dry location)	Surface	6A	32-165F
	24V DC	144W				

Dimension

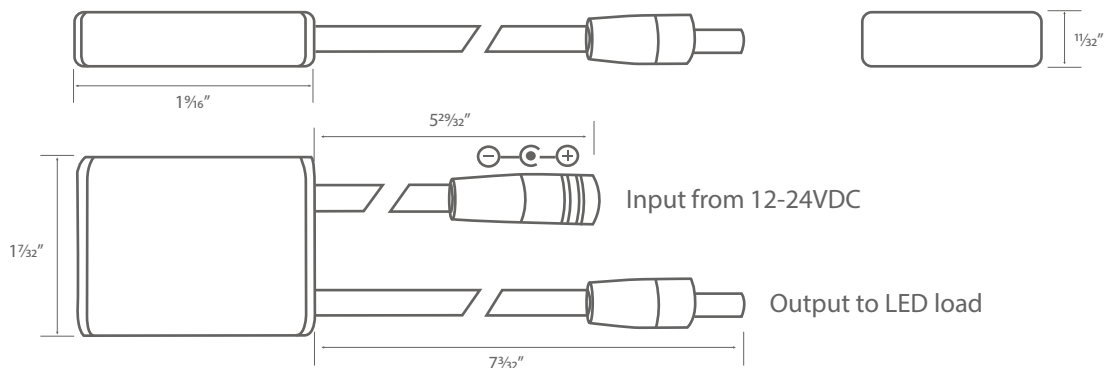

Instruction

- 1) Touch the dimmer metal body.
- 2) If touch less than 5 seconds, lights will turn on/off.
- 3) If touch more than 5 seconds, lights will dim up or down.

