

Touch Button Switch - M16



• Touch button switch-M16 is a dimmer switch for LED low voltage lights. It is a metallic contact switch with recessed mounting. Easy and quick installation. Quick press to turn on/off, long press to dim. Both in and out wires use DuPont connectors, which is matching the DuPont system. Product design is simple and suitable for home and light commercial use. This product only can be used for low-voltage LED light circuits.

Features

- Operating Voltage: DC 12-24V.
- Control method: Infrared photoelectric.
- Dry location, IP20
- Surface Mounted
- 2 years warranty.



Specification

Model No.	Input Voltage	Output Power	Max Load	Installation Method	Operate Temperature	Finish
AS-DC-035	12V DC 24V DC	48W	1A	Surface	5°F~176°F (-15°C~+80°C)	Metal

Dimension

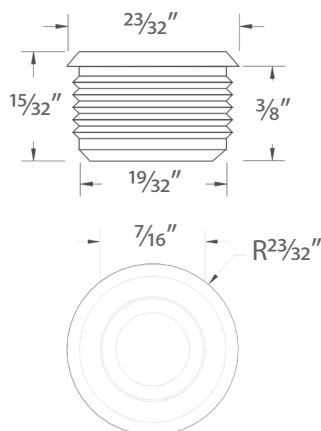

Optional Accessory

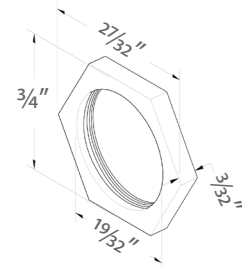
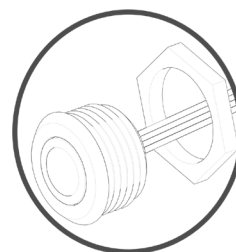

Fixing Nut

Function Introduction

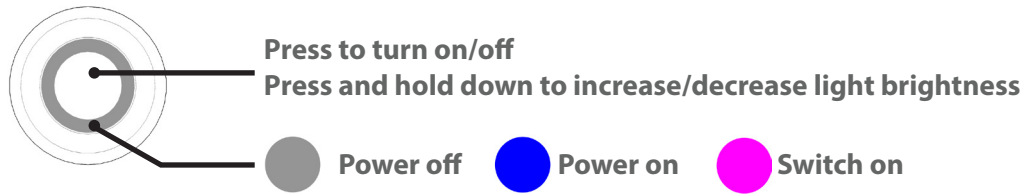

Connection Method

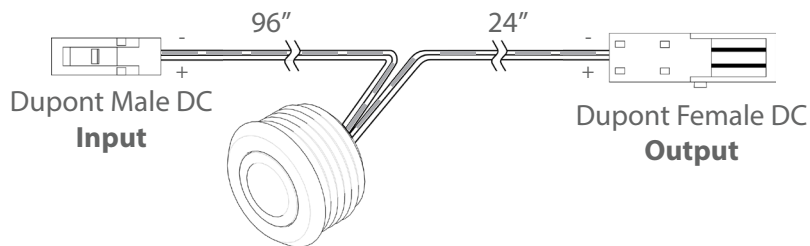

Notice

Pay attention to distinguish the input/output interface, if the wrong connection will cause the product to not work or be damaged.

Wiring Diagram

