



GL LED US LIGHTING

www.glledus.com
admin@glledus.com
(312)600-9363
501 W 18th St, Chicago, IL 60616

GL LED US LIGHTING

Commercial Light Catalog 2022 V1



Energy Conservation



Environmental



Long Life Time





Area Light (Shoebox) - Page 03



Area Light (Shoebox) - Page 03



Area Light (Shoebox) - Page 04



Slim Canopy Light - Page 18

Contents

- LED Area Light (Shoebox) Series.....03
- LED Flood Light Series.....07
- LED Wall Pack Series.....10
- LED Glass Wall Pack Series11
- LED Full-cutoff Wall Pack Series.....12
- LED Adjustable Wall Pack Series.....13
- LED Semi-cutoff Wall Pack Series14
- LED Gas Station Canopy Light Series.....16
- LED Slim Canopy Series.....18
- LED Parking Garage Canopy Series.....19
- LED UFO Highbay Series 20
- LED Linear Highbay Series21
- LED Back-Lit Panel Light Series.....23
- Tunable Center Basket Troffer Light 24
- Vertical Tenon Adaptor Series..... 25
- Round Bullhorn Series..... 26

What are the Advantages of GL LED AREA LIGHT (SHOEBOX)?

- ★ DLC UL Listed.
- ★ Power: 60W, 100W, 150W, 200W and 300W.
- ★ Input Voltage: 100~277V or 200~480V.
- ★ Color Temperature with DLC: 4000K/5000K/5700K.
- ★ Lighting Angle: Type II, Type III, Type V, Type Vs.
- ★ Photocell or Shorting Cap available.
- ★ Arm Mount (For Square or Round Pole), Slip Fitter, Slip Fitter Adapter and Trunnion available.
- ★ Motion Sensor available.

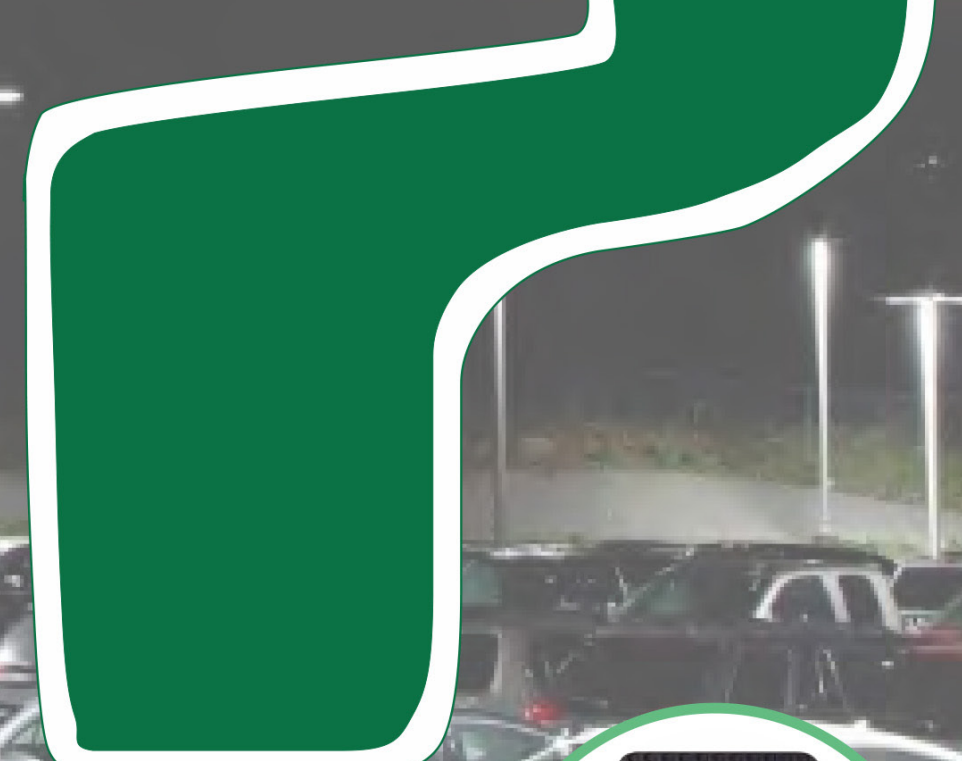

Arm Mount



Slip Fitter

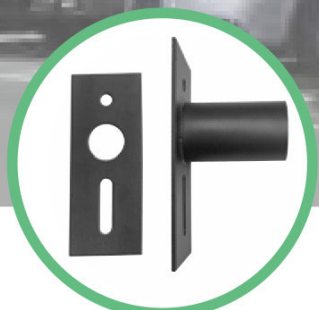

Slip Fitter Adapter



Trunnion



Arm Photocell



Slip Fitter Photocell

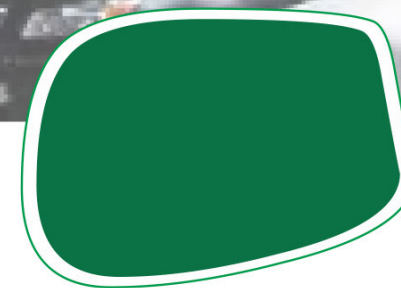

60W 100W LED Shoebox Light



Product description

- High efficiency LED Driver, the wide range input voltage AC120-277V;
- Lumileds LED high luminous efficiency and long life.
- Cast aluminium design, better cooling and easy replacement, light quality, LED Tj < 85°C.
- Excellent optical design, greatly improve the light utilization and evenness.
- Photocell control and Motion sensor available(Option)
- DLC 5.1

Item number(s)

GL-SB-AC27-60W-50K-DB-T3-ARM
GL-SB-AC27-100W-50K-DB-T3-ARM

Structure Features

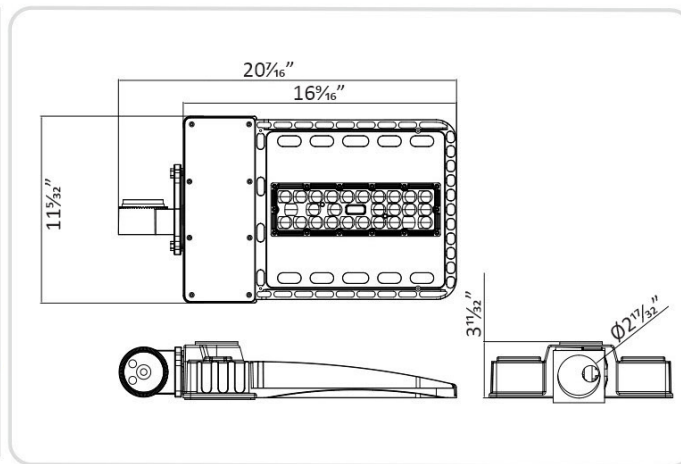

Light Distribution Curve

LUMINOUS INTENSITY DISTRIBUTION DIAGRAM

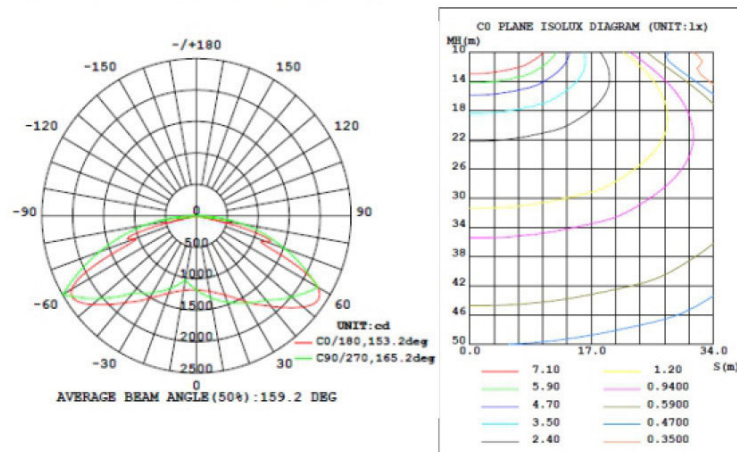

Technical Parameters

Power	Input Voltage	PF	CRI	Luminous Flux
60W	AC120~277V	>0.95	Ra>70	8700 Lm(5000K)
100W	AC120~277V	>0.95	Ra>70	13000 Lm(5000K)
Protection Level	Lighting Angle	L70 Life	LED Chips	
Wet Location/IP65	Type II, Type III, Type IV, Type V	>50,000 hrs	Lumileds LED	

150W 200W LED Shoebox Light



Product description

- High efficiency LED Driver, the wide range input voltage AC120-277V;
- Lumileds LED high luminous efficiency and long life.
- Cast aluminium design, better cooling and easy replacement, light quality, LED Tj < 85°C.
- Excellent optical design, greatly improve the light utilization and evenness.
- Photocell control and Motion sensor available(Option)
- DLC 5.1

Item number(s)

GL-SB-AC27-150W-50K-DB-T3-ARM
GL-SB-AC27-200W-50K-DB-T3-ARM

Light Distribution Curve

LUMINOUS INTENSITY DISTRIBUTION DIAGRAM

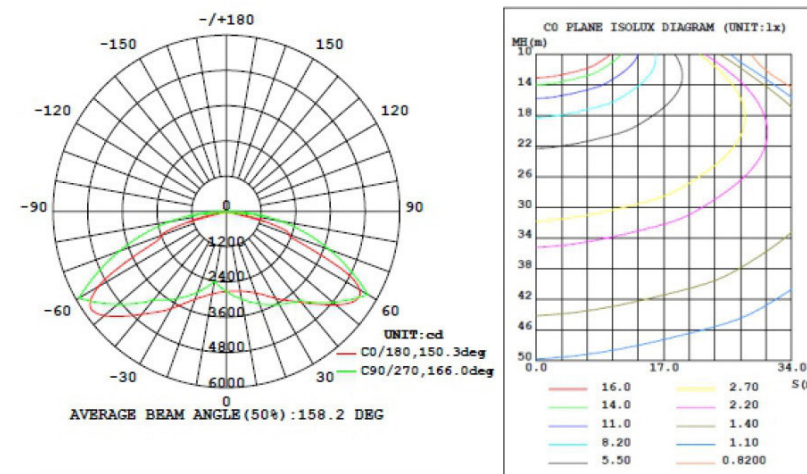

Technical Parameters

Power	Input Voltage	PF	CRI	Luminous Flux
150W	AC120~277V	>0.95	Ra>70	21000 Lm(5000K)
200W	AC120~277V	>0.95	Ra>70	27000 Lm(5000K)
Protection Level	Lighting Angle	L70 Life	LED Chips	
Wet Location/IP65	Type II, Type III, Type IV, Type V	>50,000 hrs	Lumileds LED	

Structure Features

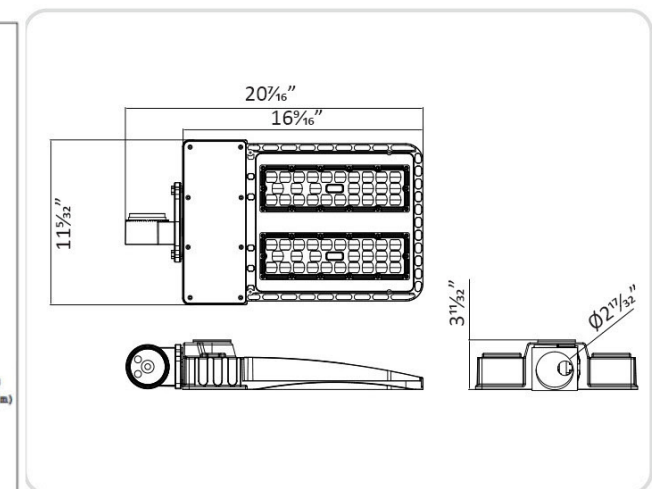

300W LED Shoebox Light



Product description

- High efficiency LED Driver, the wide range input voltage AC120-277V;
- Lumileds LED high luminous efficiency and long life.
- Cast aluminium design, better cooling and easy replacement, light quality, LED Tj < 85°C.
- Excellent optical design, greatly improve the light utilization and evenness.
- Photocell control and Motion sensor available(Optional)
- DLC 5.1

Item number(s)

GL-SB-AC27-300W-50K-DB-T3-ARM



Light Distribution Curve

LUMINOUS INTENSITY DISTRIBUTION DIAGRAM

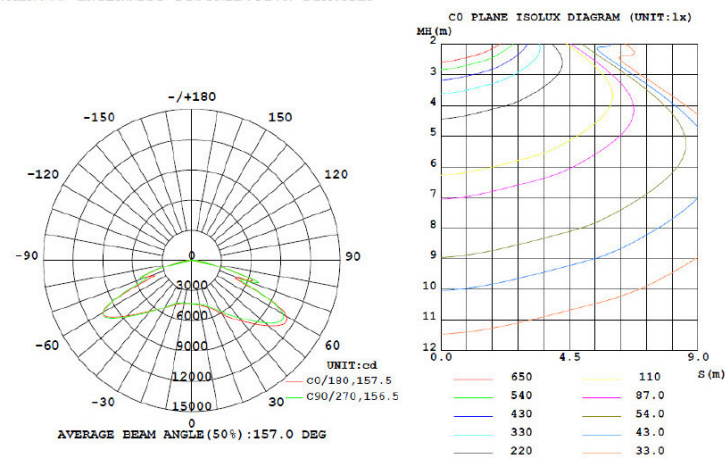

Structure Features

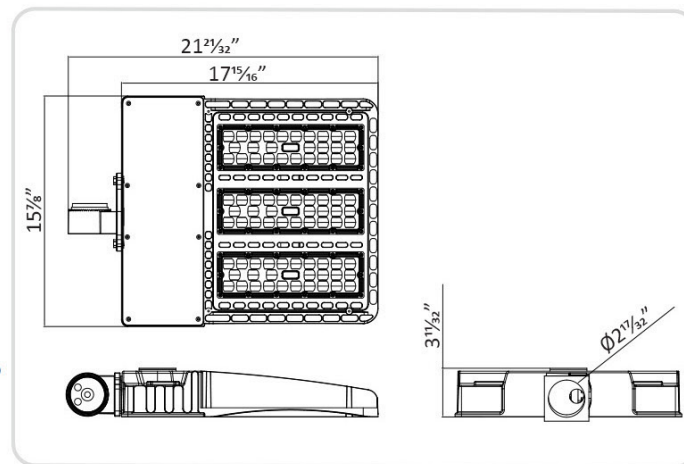

Technical Parameters

Power	Input Voltage	PF	CRI	Luminous Flux
300W	AC120~277V	>0.95	Ra>70	42132 Lm(5000K)
Protection Level	Lighting Angle	L70 Life	LED Chips	
Wet Location/IP65	Type II, Type III, Type IV, Type V	>50,000 hrs	Lumileds LED	

400W LED Shoebox Light



Product description

- High efficiency LED Driver, the wide range input voltage AC120-277V;
- Lumileds LED high luminous efficiency and long life.
- Cast aluminium design, better cooling and easy replacement, light quality, LED Tj < 85°C.
- Excellent optical design, greatly improve the light utilization and evenness.
- Photocell control and Motion sensor available(Optional)
- DLC 5.1

Item number(s)

GL-SB-AC27-400W-50K-DB-T3-ARM



Light Distribution Curve

LUMINOUS INTENSITY DISTRIBUTION DIAGRAM

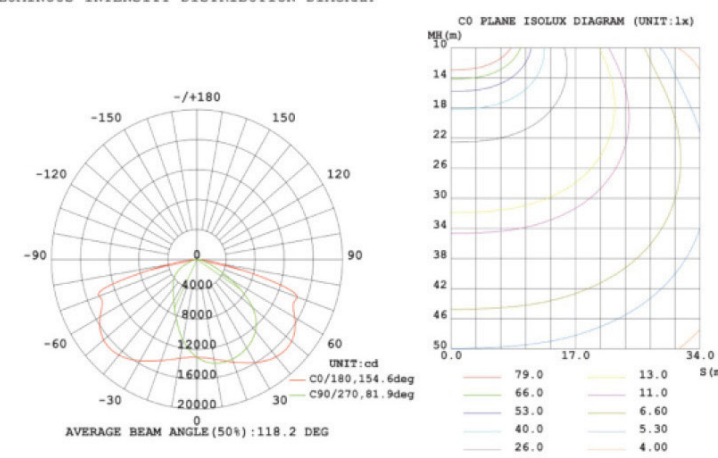

Structure Features

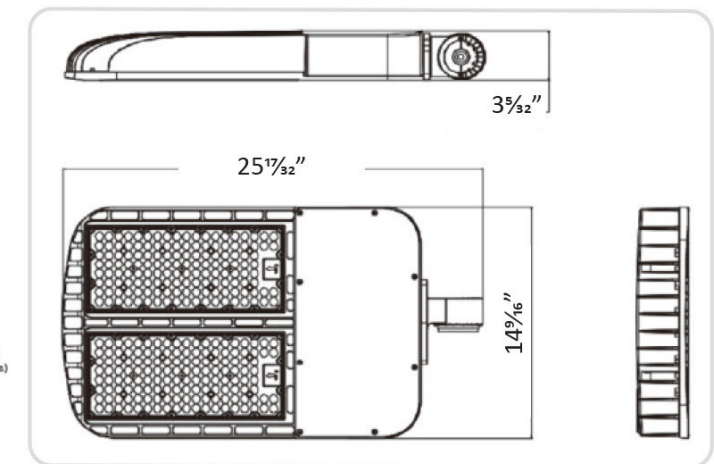

Technical Parameters

Power	Input Voltage	PF	CRI	Luminous Flux
400W	AC120~277V	>0.95	Ra>70	56783 Lm(5000K)
Protection Level	Lighting Angle	L70 Life	LED Chips	
Wet Location/IP65	Type II, Type III, Type IV, Type V	>50,000 hrs	Lumileds LED	

30W LED Flood Light



Product description

- Lumileds LED, high luminous efficiency and long working life.
- High efficiency LED Driver, the wide range input voltage AC120-277V.
- Optics design, greatly improve the light utilization and evenness.
- Photocell Control Available (Option)
- DLC 5.1

Item number(s)

GL-FL-AC27-30W-50K-DB-K

Light Distribution Curve

LUMINOUS INTENSITY DISTRIBUTION DIAGRAM

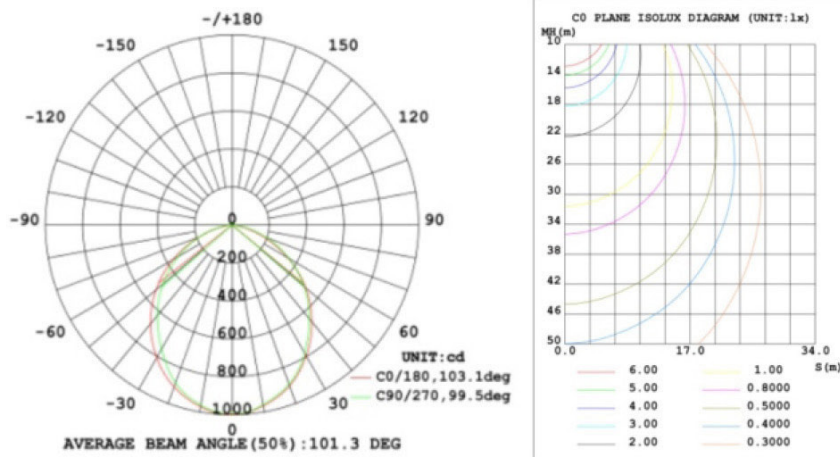

Structure Features

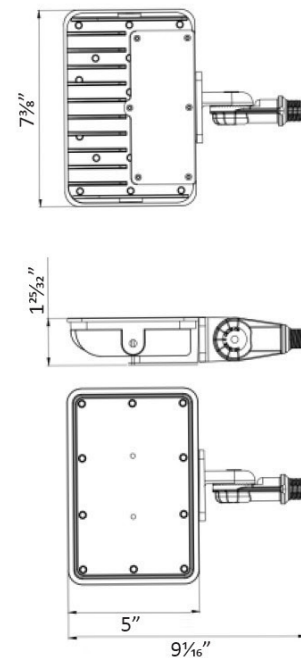

Technical Parameters

Power	Input Voltage	PF	CRI	Luminous Flux
30W	120~277V	>0.95	Ra>70	4350 Lm(5000K)
Protection Level	Lighting Angle	L70 Life	LED Chips	
Wet Location/IP65	101°	> 75,000 hrs	Lumileds LED	

70W LED Flood Light



Product description

- Lumileds LED, high luminous efficiency and long working life.
- High efficiency LED Driver, the wide range input voltage AC120-277V.
- Cast aluminium cooling design better cooling, light quality, LED Tj < 85°C.
- Excellent Optics design, greatly improve the light utilization and evenness.
- Photocell Control Available (Option)
- DLC 5.1

Item number(s)

GL-FL-AC27-70W-50K-DB-K

Light Distribution Curve

LUMINOUS INTENSITY DISTRIBUTION DIAGRAM

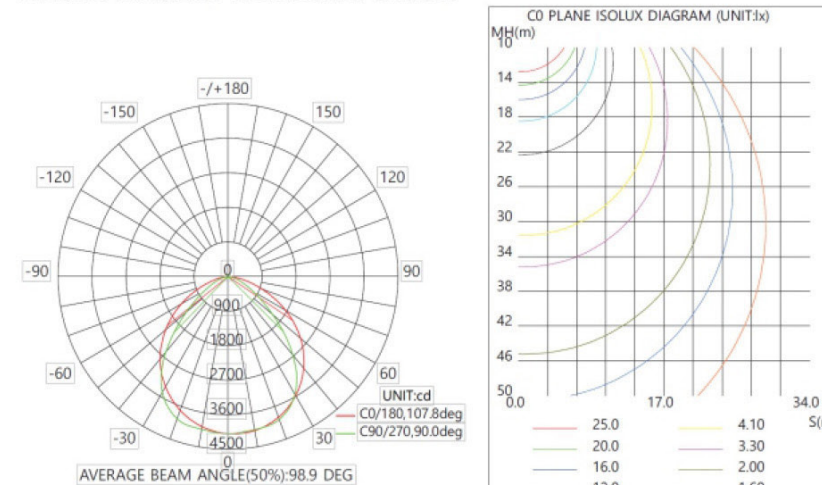

Structure Features

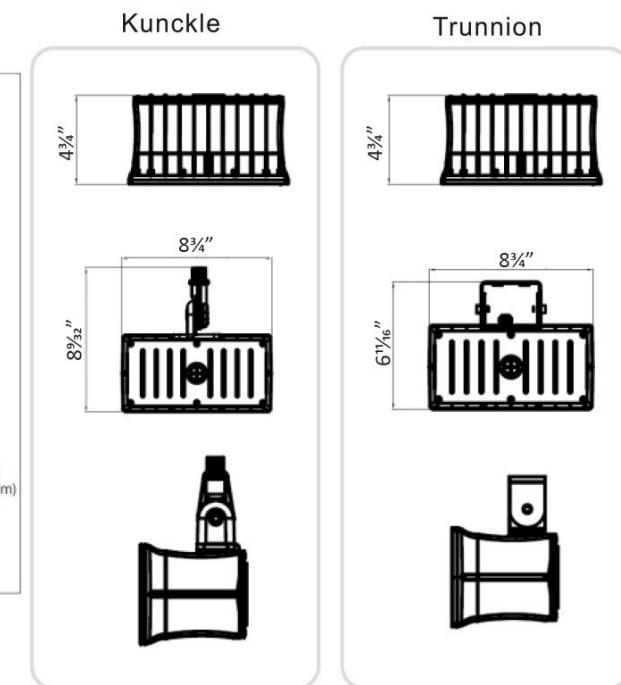

Technical Parameters

Power	Input Voltage	PF	CRI	Luminous Flux
70W	AC120~277V	>0.95	Ra>70	10441 Lm(5000K)
Protection Level	Lighting Angle	L70 Life	LED Chips	
Wet Location/IP65	98°	>50,000 hrs	Lumileds LED	

100W 200W LED Flood Light



Product description

- Lumileds LED, high luminous efficiency and long working life.
- High efficiency LED Driver, the wide range input voltage AC120-277V.
- Cast aluminium cooling design better cooling, light quality, LED Tj < 85°C.
- Excellent Optics design, greatly improve the light utilization and evenness.
- Photocell Control Available (Option)
- DLC 5.1

Item number(s)

GL-FL-AC27-100W-50K
GL-FL-AC27-200W-50K

Structure Features

Slip Fitter Mount

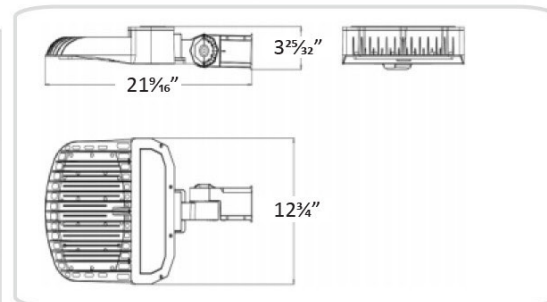

Wall Mount

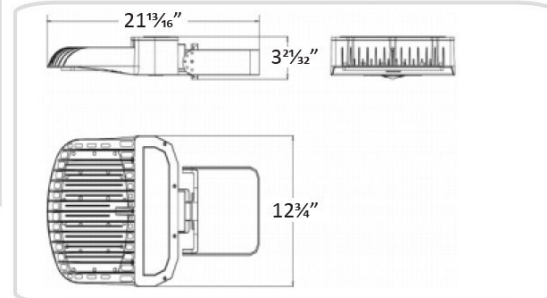

Light Distribution Curve

LUMINOUS INTENSITY DISTRIBUTION DIAGRAM

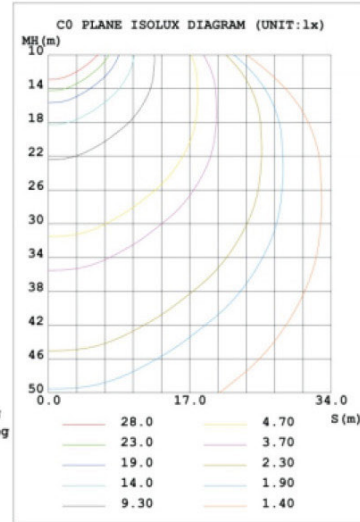
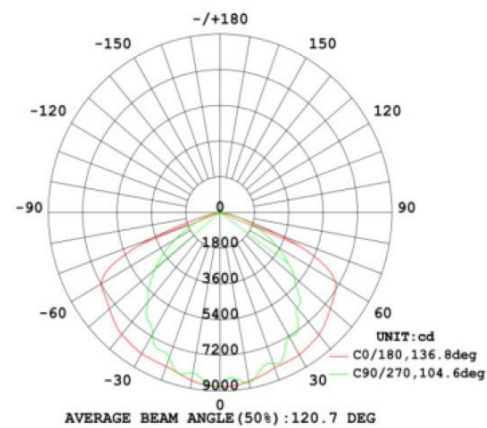

Technical Parameters

Power	Input Voltage	PF	CRI	Luminous Flux
100W 200W	AC120~277V	>0.99	Ra>70	14500 Lm(5000K) 29000 Lm(5000K)
Protection Level	Lighting Angle	L70 Life	LED Chips	
Wet Location/IP65	120°	> 75,000 hrs	Lumileds	

20W LED Wall Pack Light



Product description

- Lumileds LED, high luminous efficiency and long working life.
- High efficiency LED Driver, the wide range input voltage AC120-277V.
- Cast aluminium cooling design better cooling, better cooling, light quality, LED Tj < 85°C.
- Excellent Optics design, greatly improve the light utilization and evenness.
- Photocell Control .
- DLC 5.1

Item number(s)

GL-WP-AC27-20W-50K-PC

Structure Features

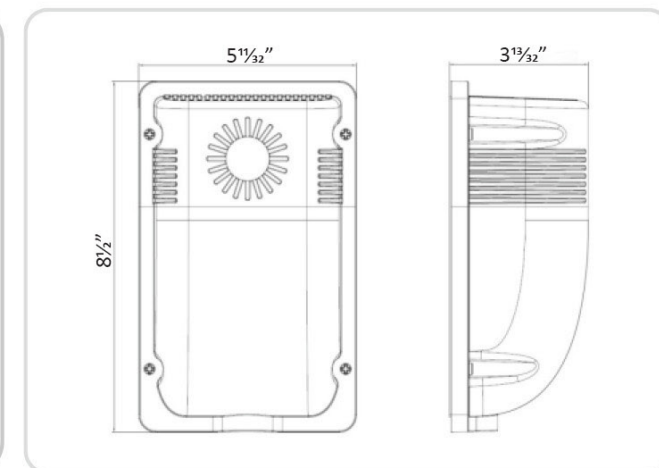

Light Distribution Curve

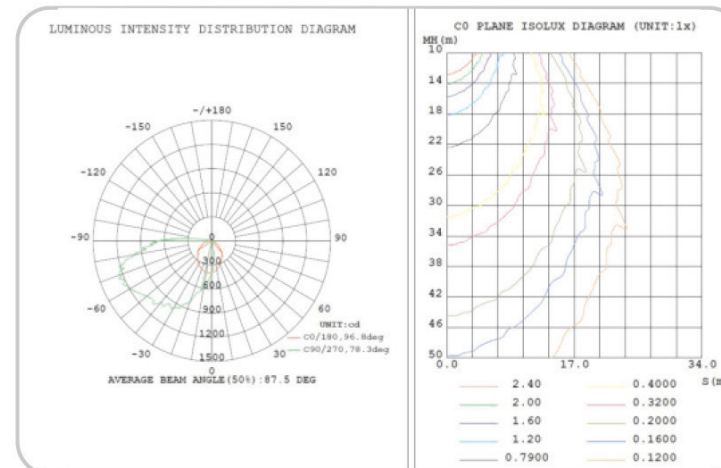

Technical Parameters

Power	Input Voltage	PF	CRI	Luminous Flux
20W	120~277V	>0.95	Ra>80	2420 Lm(5000K)
Protection Level	Lighting Angle	L70 Life	LED Chips	
Wet Location/IP65	93°	> 75,000 hrs	Lumileds LED	

70W 100W LED Glass Wall Pack



Product description

- Lumileds LED, high luminous efficiency and long working life.
- High efficiency LED Driver, the wide range input voltage AC120-277V.
- Die cast aluminum cooling design, high quality and better cooling for LED Tj < 85°C.
- Excellent Optics design, greatly improve the light utilization and evenness, glass material.
- Photocell Control Available (Optional)
- DLC 5.1

Item number(s)

GL-GWP-AC27-70W-50K-DB
GL-GWP-AC27-100W-50K-DB

Light Distribution Curve

LUMINOUS INTENSITY DISTRIBUTION DIAGRAM

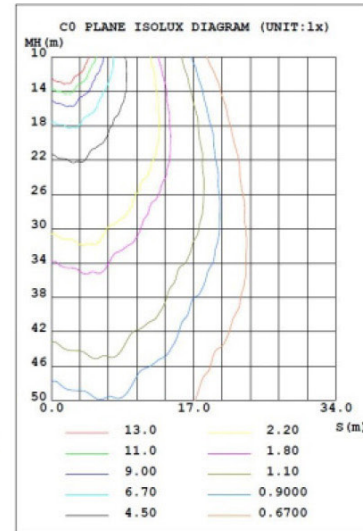
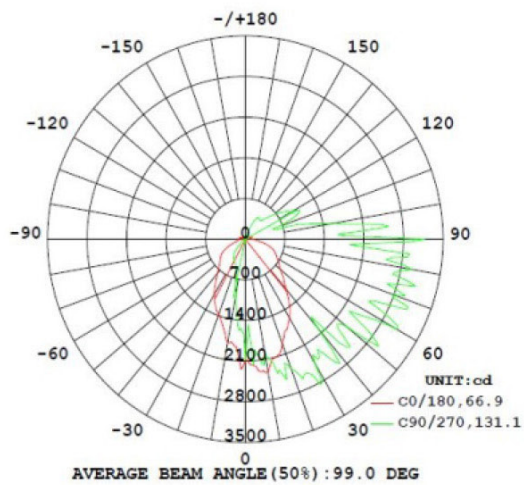

Structure Features

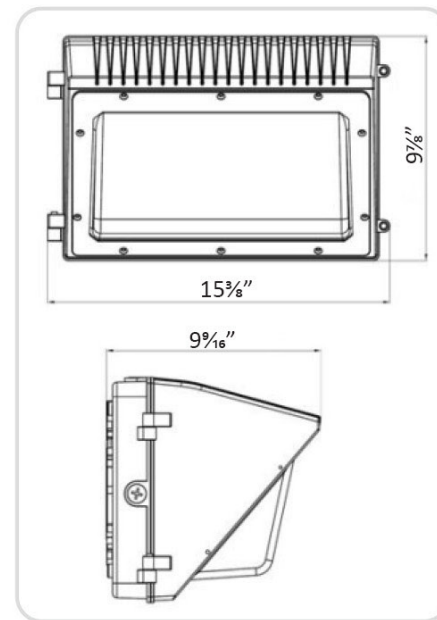

Technical Parameters

Power	Input Voltage	PF	CRI	Luminous Flux
70W	120~277V	>0.95	Ra>70	9380 Lm(5000K)
100W	120~277V	>0.95	Ra>70	13500 Lm(5000K)
Protection Level	Lighting Angle	L70 Life	LED Chips	
Wet Location/IP65	87° 118°	> 75,000 hrs	Lumileds LED	

70W LED Full Cutoff Wall Pack



Product description

- Lumileds LED, high luminous efficiency and long working life.
- High efficiency LED Driver, the wide range input voltage AC120-277V.
- Excellent optics design, greatly improve the light utilization and evenness.
- Motion sensor control available (Optional)
- 1-10V Dimming.

Item number(s)

GL-FWP-AC27-70W-50K-DB

Light Distribution Curve

LUMINOUS INTENSITY DISTRIBUTION DIAGRAM

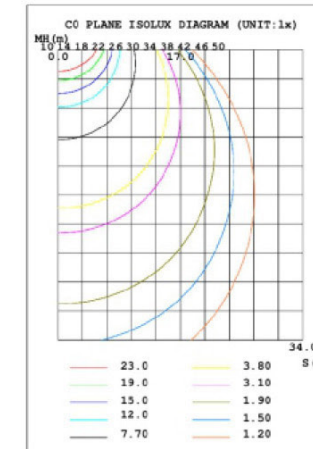
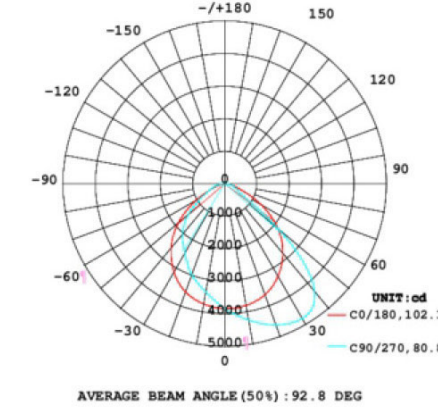

Structure Features

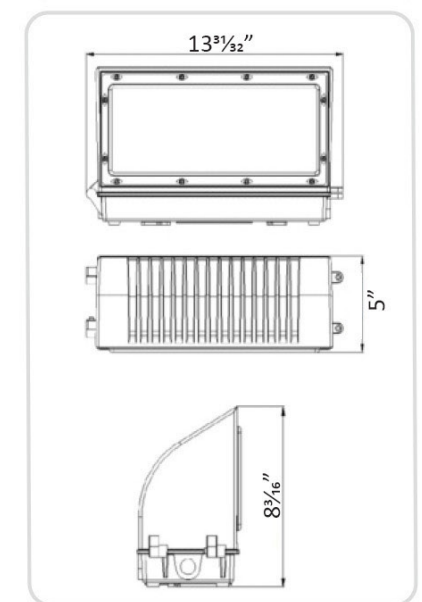

Technical Parameters

Power	Input Voltage	PF	CRI	Luminous Flux
70W	AC120~277V	>0.95	Ra>70	10500 Lm(5000K)
Protection Level	Lighting Angle	L70 Life	LED Chips	
Wet Location/IP65	82° 102°	> 75,000 hrs	Lumileds LED	

70W 100W LED Adjustable Wall Pack



Product description

- Lumileds LED, high luminous efficiency and long working life.
- High efficiency LED Driver, the wide range input voltage AC120-277V.
- Cast aluminium cooling design , better cooling, light in weight, LED Tj < 85°C.
- Excellent lampshade design, greatly improve the light utilization and evenness.
- Photocell Control Available (Option)
- DLC 5.1

Item number(s)

GL-AWP-AC27-70W-50K-DB
GL-AWP-AC27-100W-50K-DB

70W LED Semi-cutoff Wall Pack



Product description

- Lumileds LED, high luminous efficiency and long working life.
- High efficiency LED Driver, the wide range input voltage AC120-277V.
- Cast aluminium cooling design , better cooling, light in weight, LED Tj < 85°C.
- Excellent lampshade design, greatly improve the light utilization and evenness.
- The 1-10V Dimming type is continuous.
- DLC 5.1

Item number(s)

GL-HWP-AC27-70W-50K-DB

Light Distribution Curve

LUMINOUS INTENSITY DISTRIBUTION DIAGRAM

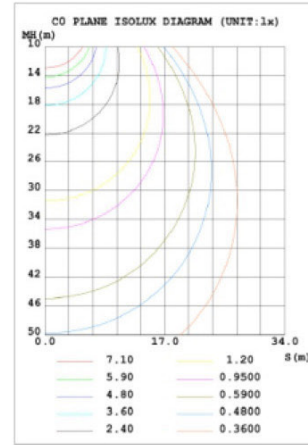
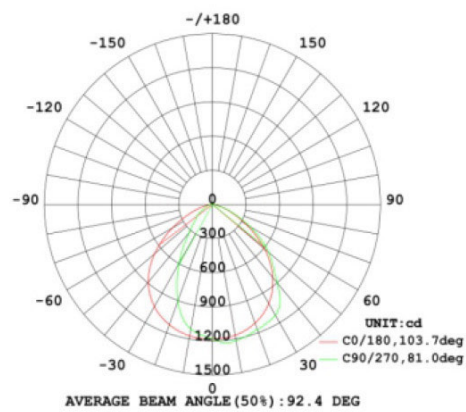

Structure Features

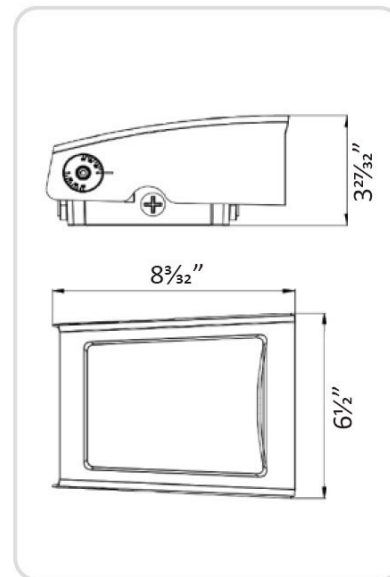

Technical Parameters

Power	Input Voltage	PF	CRI	Luminous Flux
70W 100W	120~277V	>0.98	Ra>70	9170 Lm(5000K) 13100 Lm(5000K)
Protection Level	Lighting Angle	L70 Life	LED Chips	
Wet Location/IP66	87°(70W) 89°(100W)	> 75,000 hrs	Lumileds LED	

Light Distribution Curve

LUMINOUS INTENSITY DISTRIBUTION DIAGRAM

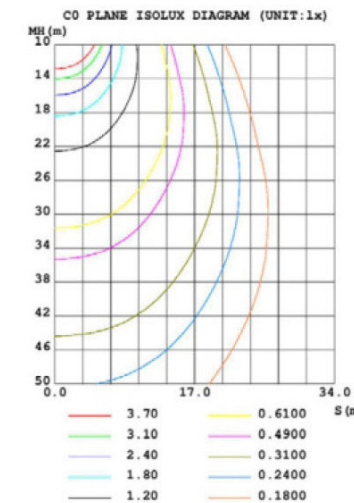
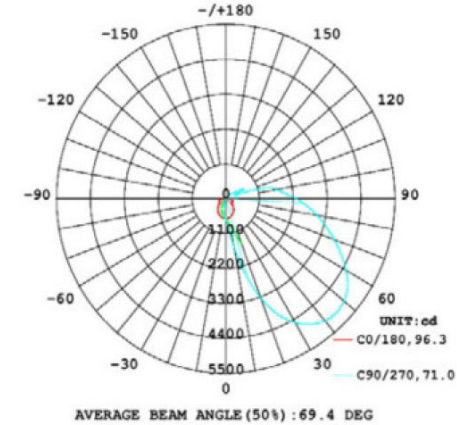

Structure Features

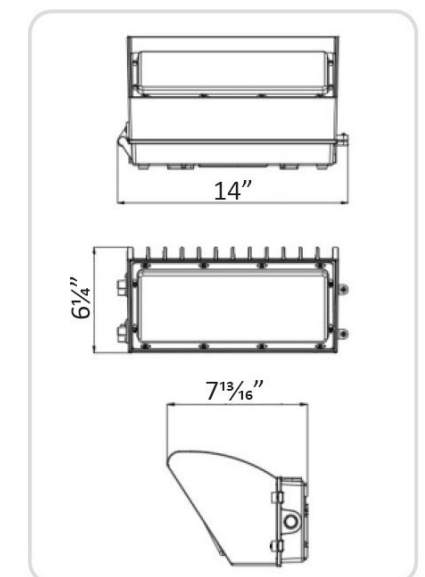

Technical Parameters

Power	Input Voltage	PF	CRI	Luminous Flux
70W	AC120~277V	>0.95	Ra>70	10150 Lm(5000K)
Protection Level	Lighting Angle	L70 Life	LED Chips	
Wet Location/IP65	96.3° 71°	> 75,000 hrs	Lumileds LED	

120W LED Semi-cutoff Wall Pack



Product description

- Lumileds LED, high luminous efficiency and long working life.
- High efficiency LED Driver, the wide range input voltage AC120-277V/AC 277-480V.
- Excellent optics design, greatly improve the light utilization and evenness.
- Motion sensor control available (Optional)
- 1-10V Dimming.
- DLC 5.1.

Item number(s)

GL-HWP-AC27-120W-50K-DB



Light Distribution Curve

LUMINOUS INTENSITY DISTRIBUTION DIAGRAM

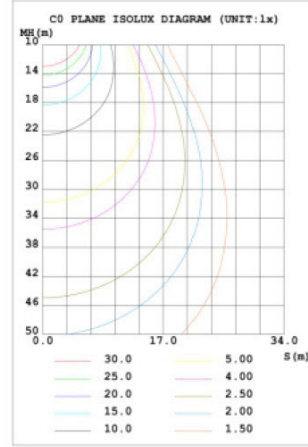
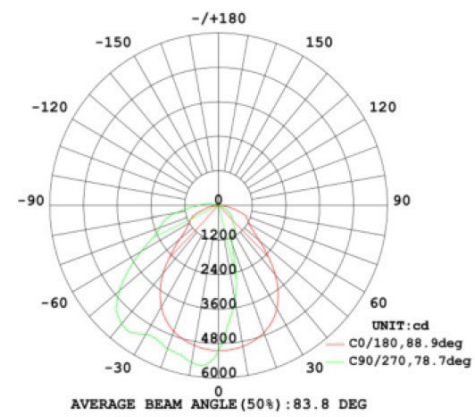

Structure Features

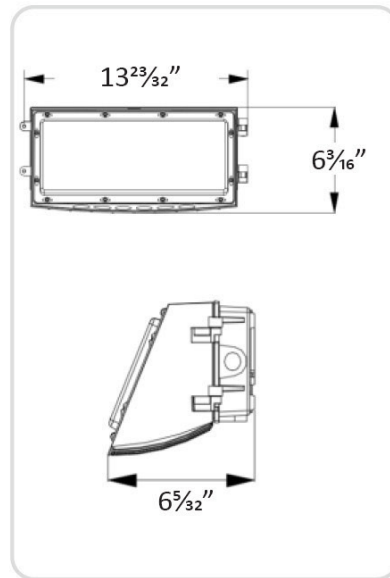

Technical Parameters

Power	Input Voltage	PF	CRI	Luminous Flux
120W	AC120~277V	>0.95	Ra>70	17035 Lm(5000K)
Protection Level	Lighting Angle	L70 Life	LED Chips	
Wet Location/IP66	148° 77.3°	> 75,000 hrs	Lumileds LED	

95W 120W LED Gas Station Canopy Light



Product description

- Lumileds LED, high luminous efficiency and long working life.
- High efficiency LED Driver, the wide range input voltage AC100-277V.
- Cast aluminium cooling design, better cooling, light in weight, LED Tj < 85°C.
- Excellent lampshade design, greatly improve the light utilization and evenness.
- Motion Sensor Available (Optional)
- DLC 5.1

Item number(s)

GL-GCP-AC27-95W-50K-W
GL-GCP-AC27-120W-50K-W



Light Distribution Curve

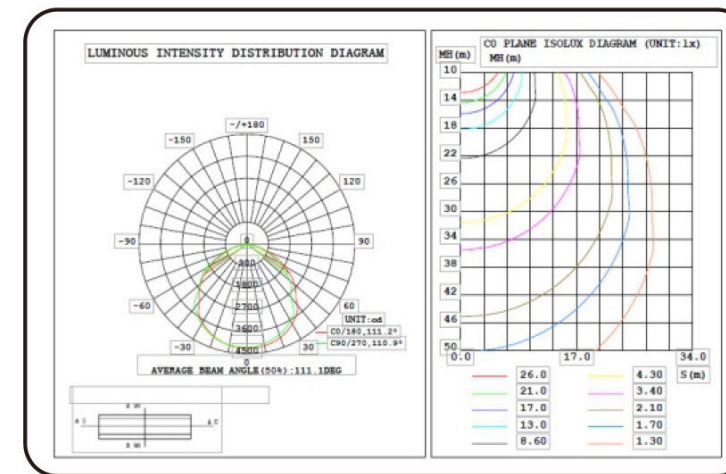

Technical Parameters

Power	Input Voltage	PF	CRI	Luminous Flux
95W	100~277V	>0.95	Ra>80	11800 Lm(5000K)
120W				16490 Lm(5000K)
Protection Level	Lighting Angle	L70 Life	LED Chips	
Wet Location/IP65	111°	>50,000 hrs	Lumileds LED	

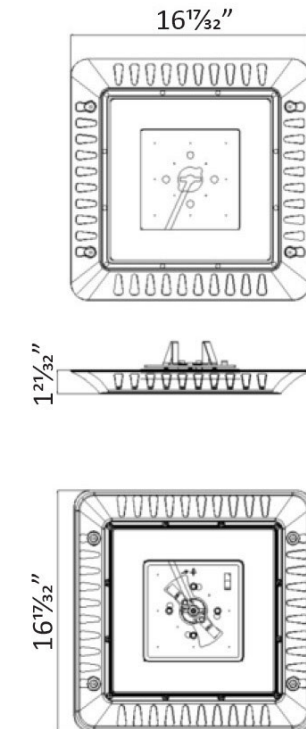

150W 200W LED Gas Station Canopy Light



Product description

- Lumileds LED, high luminous efficiency and long working life.
- High efficiency LED Driver, the wide range input voltage AC120-277V;
- Cast aluminium cooling design, better cooling, light in weight, LED Tj < 85°C.
- Excellent lampshade design, greatly improve the light utilization and evenness.
- DLC 5.1



Item number(s)

GL-GSL-AC27-150W-50K
GL-GSL-AC27-200W-50K

Light Distribution Curve

Luminous Intensity Distribution

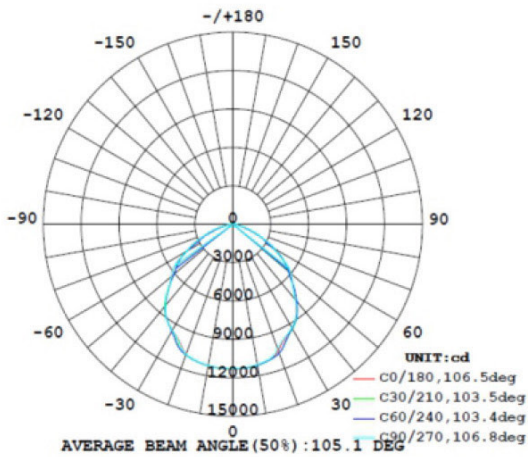

Structure Features

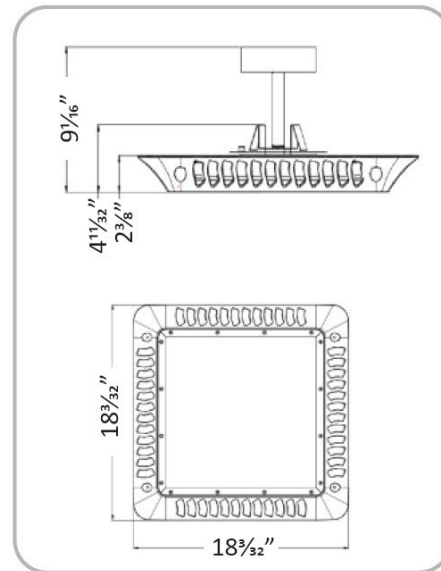
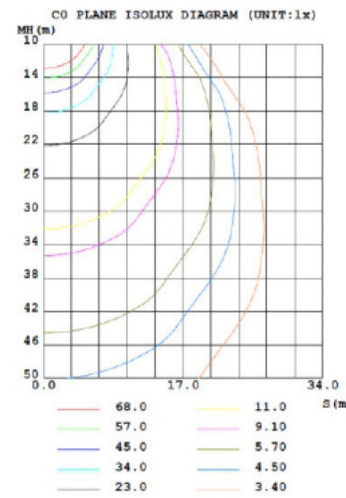

Technical Parameters

Power	Input Voltage	PF	CRI	Luminous Flux
150W	AC120~277V	>0.98	Ra>70	21200 Lm(5000K)
200W				28400 Lm(5000K)
Protection Level	Lighting Angle	L70 Life	LED Chips	
Wet Location	105°	>50,000 hrs	Lumileds LED	

45W 65W LED Slim Canopy Light



Product description

- Lumileds LED, high luminous efficiency and long working life.
- Suitable for Wet location, IP65.
- Input AC120-277V, DLC approved.
- Complete surface mount, 3/4 inch pendant conduit.
- Optional motion sensor.
- DLC 5.1



Item number(s)

GL-SCP-AC27-45W-50K-DB
GL-SCP-AC27-65W-50K-DB

Light Distribution Curve

LUMINOUS INTENSITY DISTRIBUTION DIAGRAM

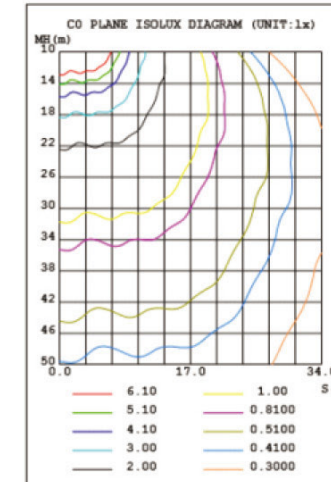
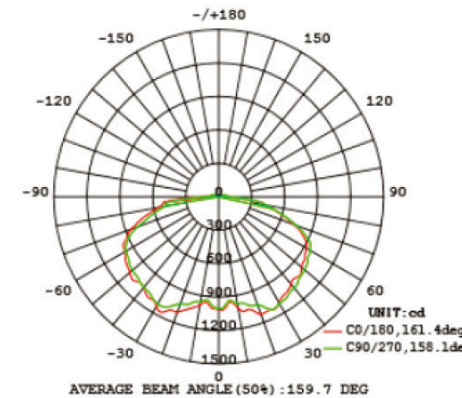

Structure Features

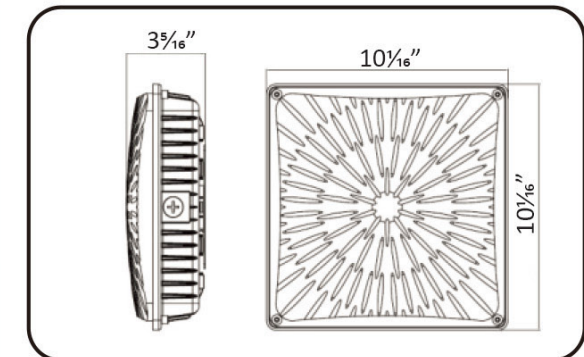

Technical Parameters

Power	Input Voltage	PF	CRI	Luminous Flux
45W	120~277V	>0.95	Ra>70	6075 Lm(5000K)
65W	120~277V	>0.95	Ra>70	8775 Lm(5000K)
Protection Level	Lighting Angle	L70 Life	LED Chips	
Wet Location/IP65	130°	>75,000 hrs	Lumileds LED	

70W LED Parking Garage Canopy Light



Product description

- Lumileds LED, high luminous efficiency and long working life.
- High efficiency LED Driver, the wide range input voltage AC120-277V.
- Die Cast aluminium cooling design, high quality and better cooling for LED Tj < 85°C.
- Excellent Optics design, greatly improve the light utilization and evenness.
- Motion Sensor Control Available (Optional)
- DLC 5.1

Item number(s)

GL-PGC-AC27-70W-50K-DB

Light Distribution Curve

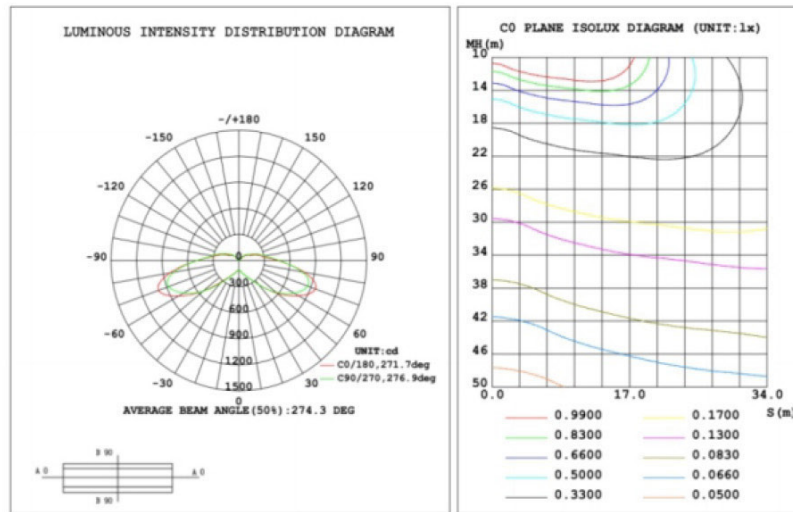

Structure Features

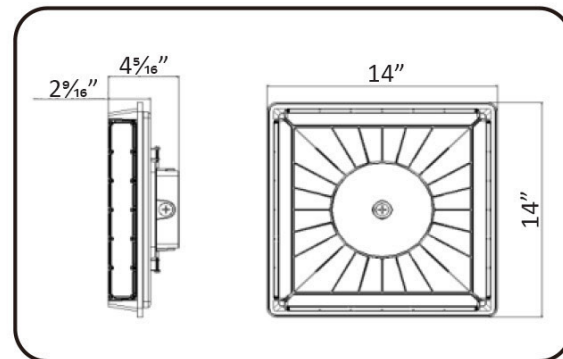

Technical Parameters

Power	Input Voltage	PF	CRI	Luminous Flux
70W	120~277V	>0.95	Ra>70	8750 Lm(5000K)
Protection Level	Lighting Angle	L70 Life	LED Chips	
Wet Location/IP65	270°	> 75,000 hrs	Lumileds LED	

100W 150W 200W LED UFO High Bay Light



Product description

- LED high luminous efficiency and long working life.
- High efficiency LED Driver, the wide range input voltage AC120-277V..
- Die Cast aluminium cooling design, high quality and better cooling for LED Tj < 85°C.
- Excellent optics design, greatly improve the light utilization and evenness.
- Motion Sensor Control Available (Optional)
- DLC 5.0

Item number(s)

GL-UFO-AC27-100W-50K-DB
GL-UFO-AC27-150W-50K-DB
GL-UFO-AC27-200W-50K-DB

Light Distribution Curve

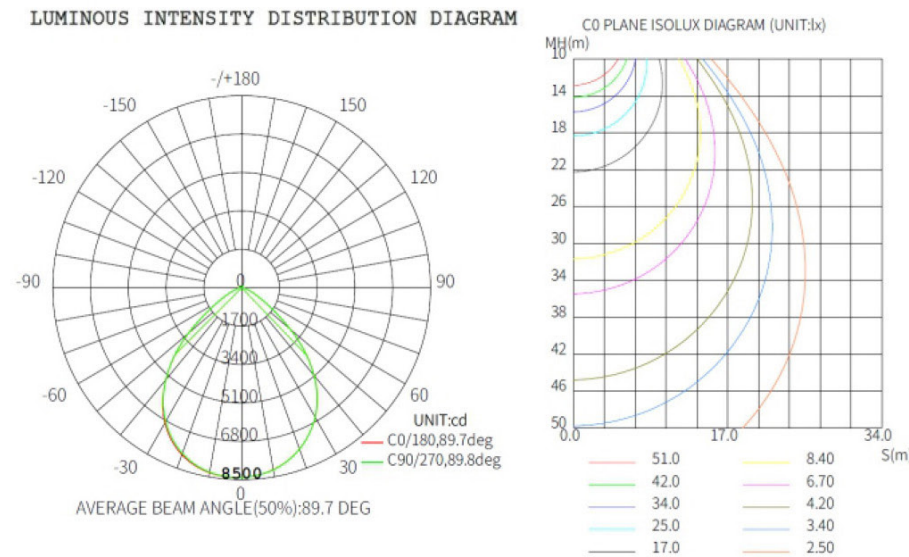

Structure Features

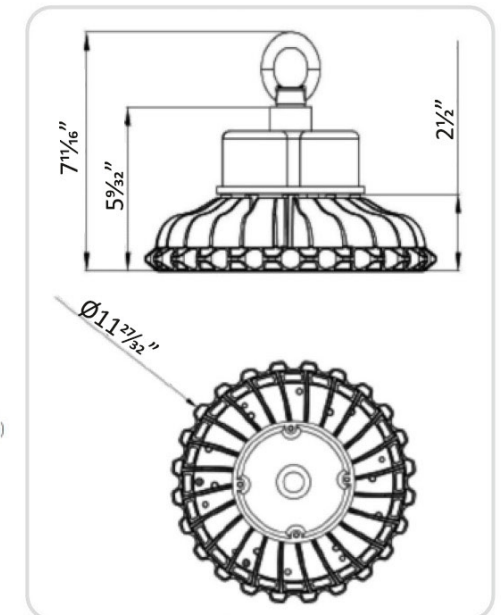

Technical Parameters

Power	Input Voltage	PF	CRI	Luminous Flux
100W	AC120~277V	>0.95	Ra>70	15600Lm(5000K)
150W				22470Lm(5000K)
200W				30001Lm(5000K)
Protection Level	Lighting Angle	L70 Life	LED Chips	
Wet Location/IP65	89°	>50,000 hrs	Lumileds LED	

85W 170W 2ft LED Linear High Bay



Item number(s)

GL-LHB-2F-AC27-85W-50K
GL-LHB-2F-AC27-170W-50K

Product description

The Linear High Bay with its all-in-one, lightweight and slim with multiple mounting situations available put it at the top of the list for any high ceiling area where super bright light is needed. The LED Linear High bay Light Series can be widely used for indoor excellent for warehouse, industry building, factories, fitness center, and many other applications

Structure Features

Shell materials: Aluminum & PC Color: White

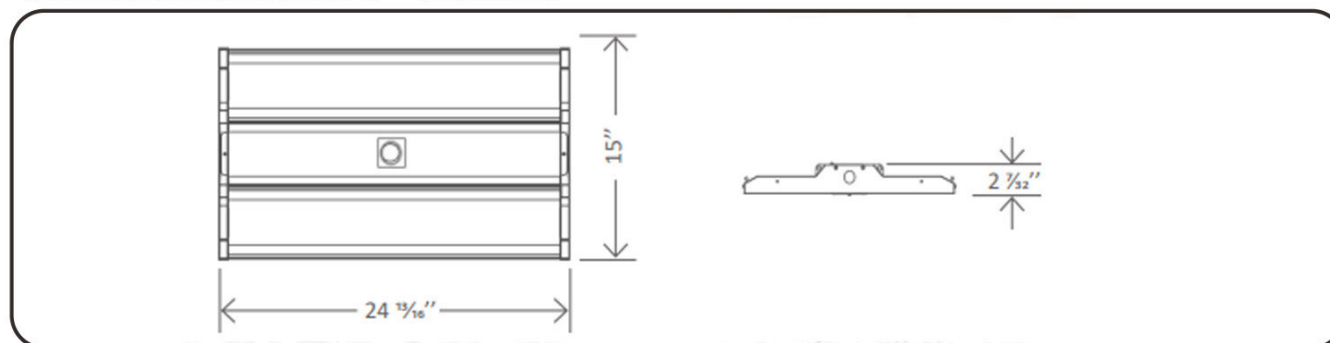

Technical Parameters

Power	Input Voltage	PF	CRI	Luminous Flux
85W	120~277V	>0.98	Ra>80	11560 Lm(5000K)
170W	120~277V	>0.98	Ra>80	23120 Lm(5000K)
Protection Level	Lighting Angle	L70 Life	LED Chips	
Dry Location/IP20	105°	>50,000 hrs	Lumileds LED	

Light Distribution Curve

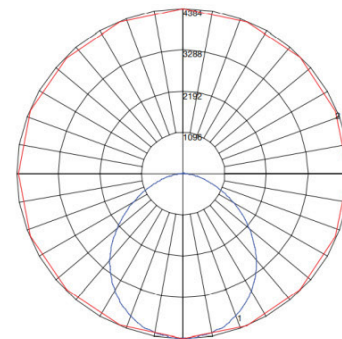

Maximum Candela = 4384.3 Located At Horizontal Angle = 90, Vertical Angle = 2
1 - Vertical Plane Through Horizontal Angles (90 - 270) (Through Max. Cd.)
2 - Horizontal Cone Through Vertical Angle (0) (Through Max. Cd.)

300W 4ft LED Linear High Bay



Item number(s)

GL-LHB-4F-AC27-300W-50K

Product description

The Linear High Bay with its all-in-one, lightweight and slim with multiple mounting situations available put it at the top of the list for any high ceiling area where super bright light is needed. The LED Linear High bay Light Series can be widely used for indoor excellent for warehouse, industry building, factories, fitness center, and many other applications

Structure Features

Shell materials: Aluminum & PC Color: White

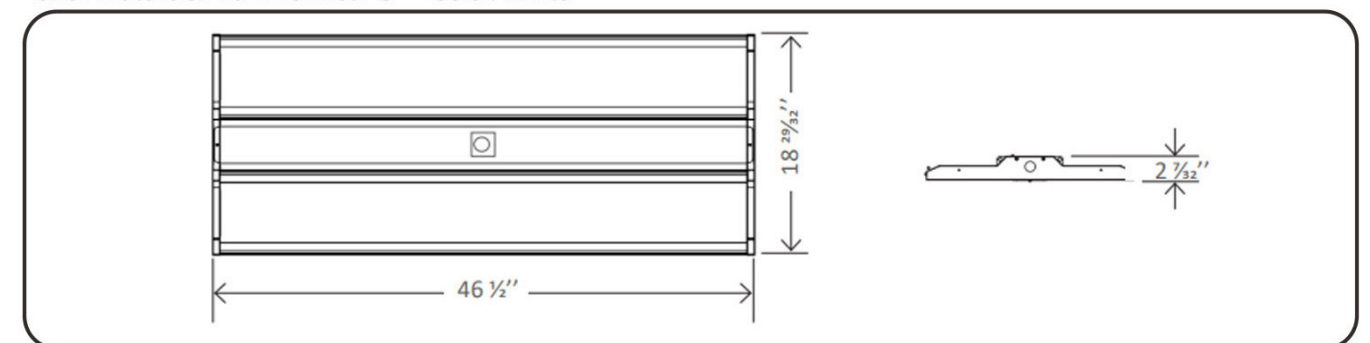

Technical Parameters

Power	Input Voltage	PF	CRI	Luminous Flux
300W	120~277V	>0.98	Ra>80	40800 Lm(5000K)
Protection Level	Lighting Angle	L70 Life	LED Chips	
Dry Location/IP20	105°	>50,000 hrs	Lumileds LED	

Light Distribution Curve

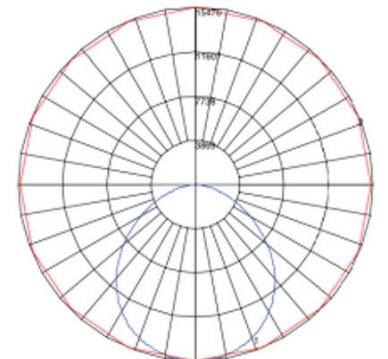

Maximum Candela = 15470.2 Located At Horizontal Angle = 90, Vertical Angle = 2
1 - Vertical Plane Through Horizontal Angles (90 - 270) (Through Max. Cd.)
2 - Horizontal Cone Through Vertical Angle (0) (Through Max. Cd.)

LED Back-Lit Panel Light



Product description

- Energy efficient: save up to 80% in energy costs
- High lumen output
- Mercury-free
- Instant-on light
- 50,000 hours at 70% lumen maintenance rated life
- CCT:3500-5000K
- 5 years manufacturer warranty
- Compatible with most Lutron and Leviton dimmers

Item number(s)

GL-22LPZ202530W27-CCT
GL-24LPZ354046W27-CCT

Structure Features

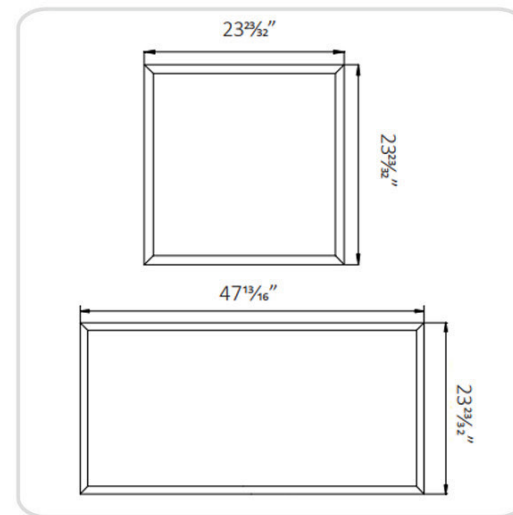

Light Distribution Curve

GL-22LPZ202530W27-CCT

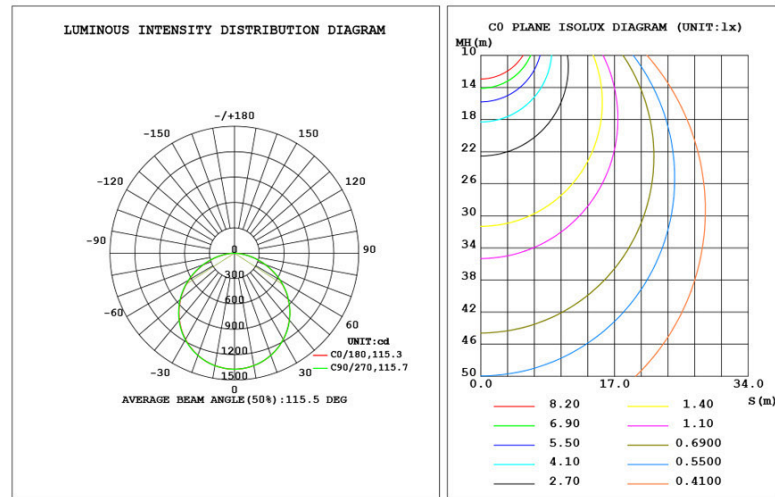

Technical Parameters

Size	Power	Input Voltage	PF	Luminous Flux
22(2*2ft)	20W	120~277V	>0.98	2660 Lm(5000)
	25W			3250 Lm(5000)
	30W			3810 Lm(5000)
24(2*4ft)	35W	120~277V	>0.98	4650 Lm(5000)
	40W			5200 Lm(5000)
	46W			5842 Lm(5000)
CRI	Protection Level	Lighting Angle	Lifespan	Cable
Ra >80	Damp	113°	>75,000 hrs	Input Connect, No Cable

LED Tunable Center Basket Troffer Light



Product description

- Energy efficient: save up to 80% in energy costs
- High lumen output
- Mercury-free
- Instant-on light
- 50,000 hours at 70% lumen maintenance rated life
- CCT:3500-5000K
- 5 years manufacturer warranty
- Compatible with most Lutron and Leviton dimmers

Item number(s)

GL-22TRF202530W27-CCT
GL-24TRF343845W27-CCT



Light Distribution Curve

GL-22TRF202530W27-CCT

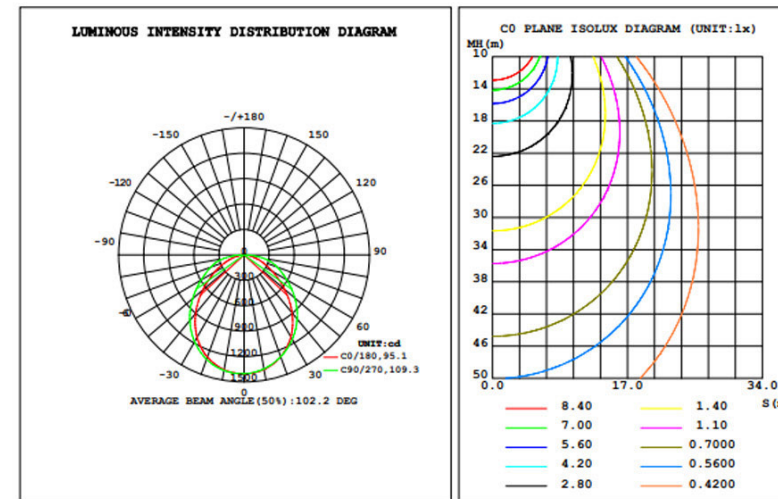

Structure Features

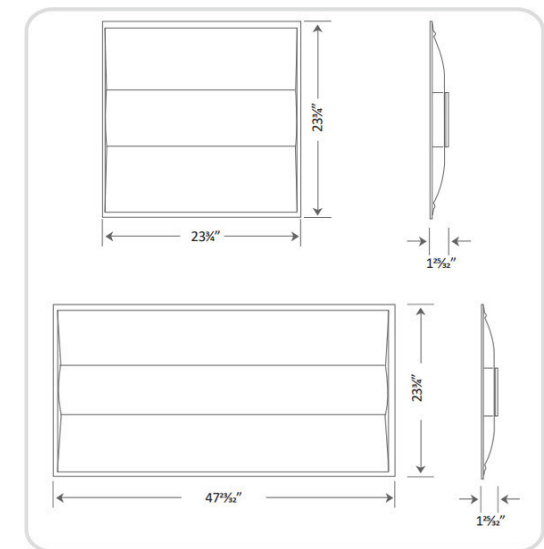

Technical Parameters

Size	Power	Input Voltage	PF	CRI	Luminous Flux
22(2*2ft)	20W	120~277V	>0.98	Ra>80	2500 Lm(5000)
	25W				3125 Lm(5000)
	30W				3750 Lm(5000)
24(2*4ft)	34W	120~277V	>0.98	Ra>80	4250 Lm(5000)
	38W				4758 Lm(5000)
	45W				5715 Lm(5000)
Protection Level	Lighting Angle	Lifespan	LED Chips		
Dry	113°	>75,000 hrs	Seoul LEDs		

Vertical Tenon Adaptor



STEEL (SBT) BOLT-ON TENON FOR SQUARE STRAIGHT STEEL POLES

Ordering Information

Example: GL-VT3-D GL-VTS4-D

GL	Series	Pole Tenon Size	Finish
	Vertical Tenon	2.5 = 2-3/8" O. D.	D = Dark Bronze
		3 = 3" O. D.	W = White
		4 = 4" O. D.	S = Silver Gray
		S4 = Fits 4" Square Pole	
		S5 = Fits 5" Square Pole	

Features & Specifications

Intended Use

For round and square straight steel poles.

Construction

Steel: Body is constructed from A500 Grade B steel. Welding follows industry standards best practices.

Weather and fade resistant polyester powder coating. Formulated for high-durability and long lasting color.

Installation

Mounting hardware is included.

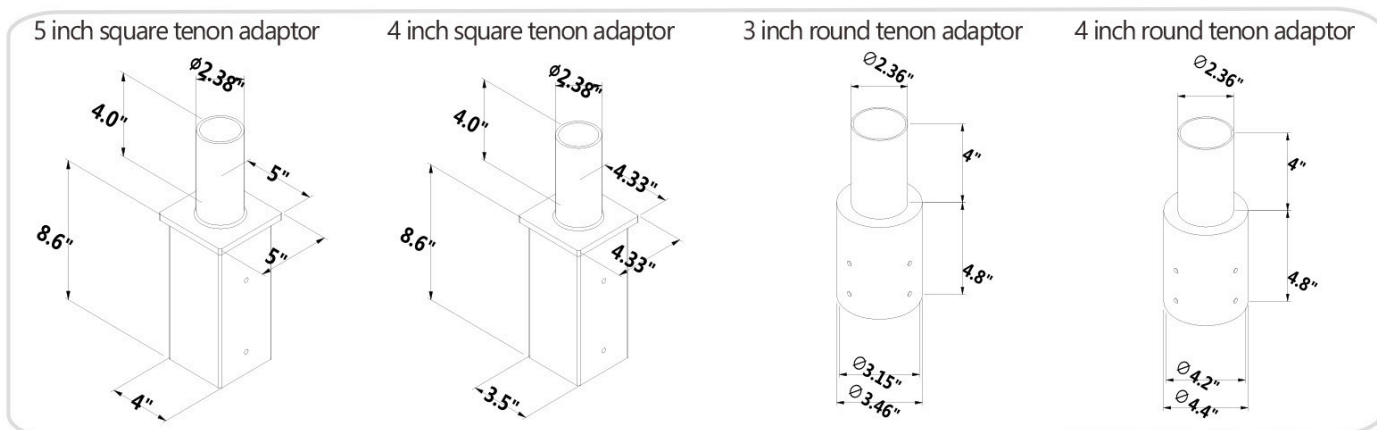

Round Bullhorn



180° Double Bullhorn

180° Triple Bullhorn

90° Quad Bullhorn

180° Double Bullhorn

Ordering Information

Example: GL-RB2.5D180-D GL-RB2.5D180H-D

GL	Series	Pole Tenon Size	Bullhorn Type	Finish
	Round Bullhorn	2.5 = 2-3/8" O. D.	D180 = Double 180°	D = Dark Bronze
		3 = 3" O. D.	TR180 = Triple 180°	W = White
		4 = 4" O. D.	QD90 = Quad 90°	S = Silver Gray
			H = Horizontal	

Technical Specifications

Construction

Finish:

Weather and fade resistant polyester powder coating.

Formulated for high-durability and long lasting color.

Bullhorns:

Tenons for slip fitters. Bullhorns fit 2 3/8" (6cm) O.D. tenons and accommodate 2 3/8" (6cm) slip fitters.

Features

Easy, secure floodlight mounting Double Reinforced weld joints

Bullhorn bracket safely supports HID floodlights.

Great with Floodzilla, Megaflood and Flexflood models.

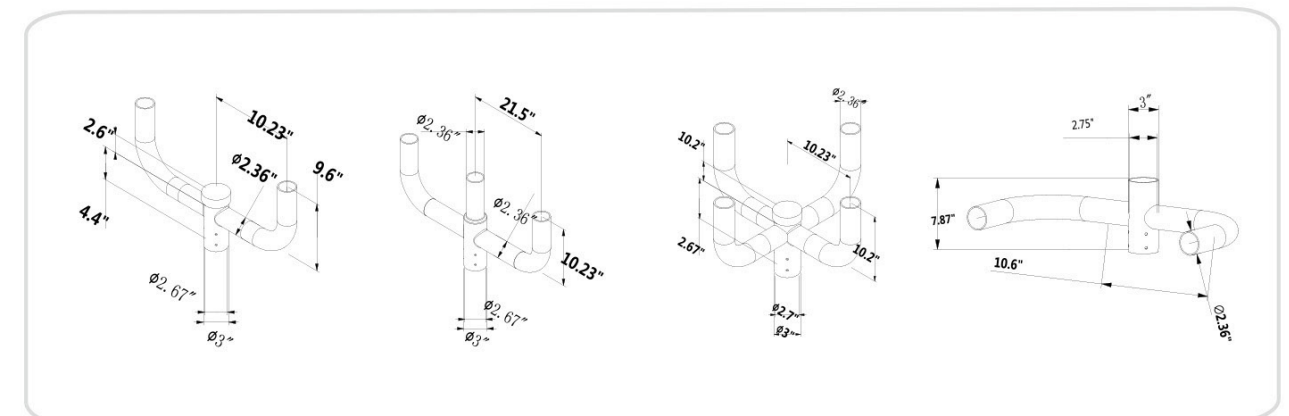

Wall Mount Adaptor



Slip Fitter Adaptor Wall Mount 90° Bracket Wall Mount 90° Bracket

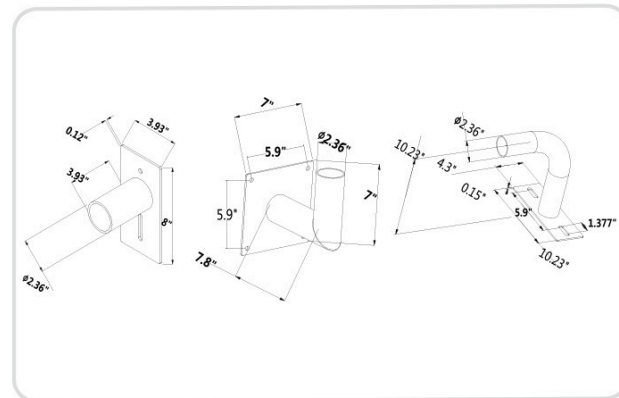

Ordering Information

Example: GL-ADP2.5-D GL-ADP2.5-90-D GL-ADP2.5-90H-D

GL	Series	Fixtures Tenon Type	Finish
	ADP2.5 = Adaptor 2-3/8"	90 = Wall Mount 90°	D = Dark Bronze
		H = Horizontal	W = White
			S = Silver Gray

Round Post Top Adaptor

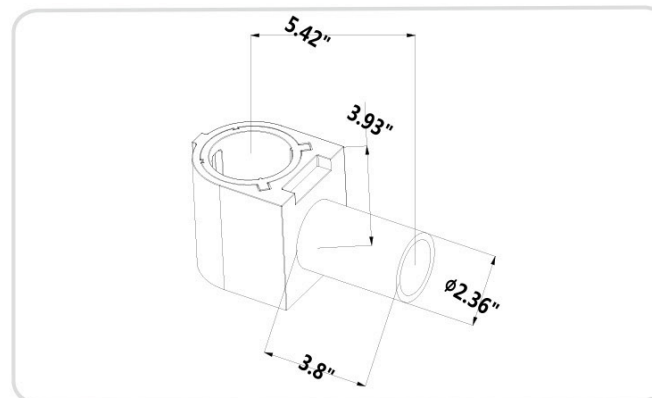
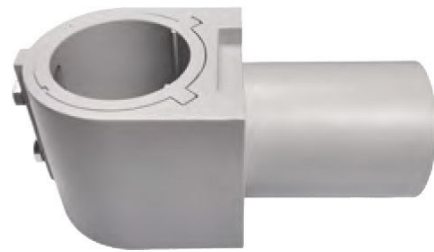

Ordering Information

Example: GL-ADP25-30-D GL-ADP25-30-W GL-ADP25-30-S

GL	Series	Pole Tenon Type	Finish
	ADP = Adaptor	25-30 = Fits 2-3/8" and 3" Pole	D = Dark Bronze
			W = White
			S = Silver Gray

Spoke Brackets



Single Spoke Bracket



Twin Spoke Bracket, 90° Arms



Twin Spoke Bracket, 180° Arms



Triple Spoke Bracket, 120° Arms



Quad Spoke Bracket, 90° Arms

Ordering Information

Example: GL-SB2.5TW90-D

GL	Series	Pole Tenon Size	Pole Tenon Size	Finish
	Spoke Brackets	2.5 = 2-3/8" O. D.	S = Single	D = Dark Bronze
		3 = 3" O. D.	TW90 = Twin90	W = White
		4 = 4" O. D.	TW180 = Twin180	S = Silver Gray
		4 = 4" O. D.	TR120 = Triple120	
			QD90 = Quad90	

