

# Aluminum Channel Suspension Kit - **SCK-NPF-H1-G1**



Aluminum Channel  
Suspension Kit - Type G1-A  
**SCK-NPF-H1-G1-A**

Aluminum Channel  
Suspension Kit - Type G1-B  
**SCK-NPF-H1-G1-B**

Aluminum Channel  
Suspension Kit - Type G1-C  
**SCK-NPF-H1-G1-C**

Aluminum Channel  
Suspension Kit - Type G1-D  
**SCK-NPF-H1-G1-D**

## Product Dimension

Unit: inch

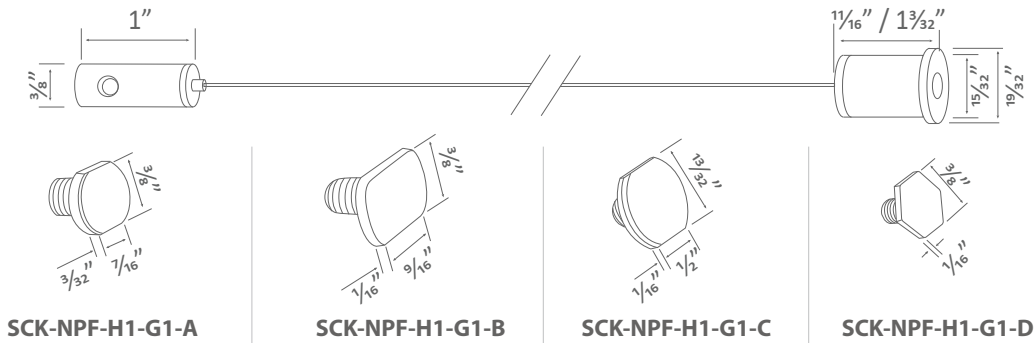

## Suitable for Aluminum Channel

Model No.	Wire Length	Aluminum Channel
SCK-NPF-H1-G1-A	58 1/4"	YD 1604, ES 3535, ES 5035, ES 7535, YD 2004
SCK-NPF-H1-G1-B	118 1/8"	YD 1604, ES 3535, ES 5035, ES 7535, A 2525, YD 2004
SCK-NPF-H1-G1-C	118 1/8"	YD 1604, YD 1418, YD 2004
SCK-NPF-H1-G1-D	118 1/8"	ES 3535, ES 5035, ES 7535, A 2525, A 3235

## Additional Accessories

Product	Model No.	Wire Length
Suspension Hanging Wire	AS-OT-012	10ft
Suspension Hanging Wire	AS-OT-018	20ft

**Installation**

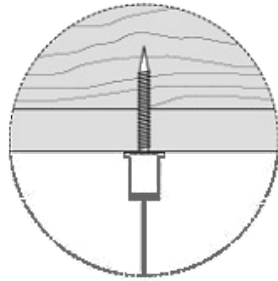

**Type G1**

**Other Styles (Additional Accessories are Needed)**

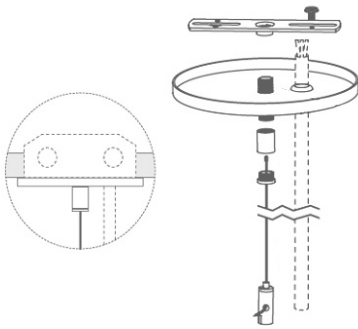

**Type A1**

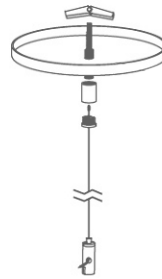
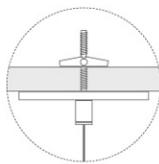

**Type C1**

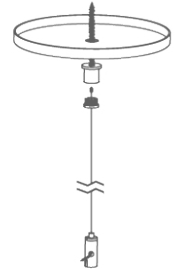
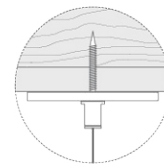

**Type D1**

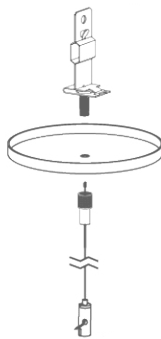
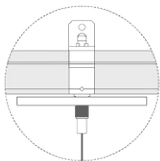

**Type E1**

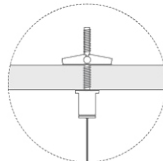

**Type F1**

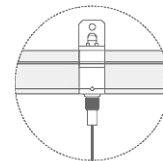

**Type H1**