

boahaus

ASSEMBLY INSTRUCTIONS

ATTENTION!!!

Any inquiry or replacement parts
you need, contact us directly at:

contact@boahaus.com

Scan this QR Code to contact to Customer Support Team.



Or Call Us at +1 (713) 701-5994

boahaus

ASSEMBLY INSTRUCTIONS INSTRUCCIONES DE ARMADO

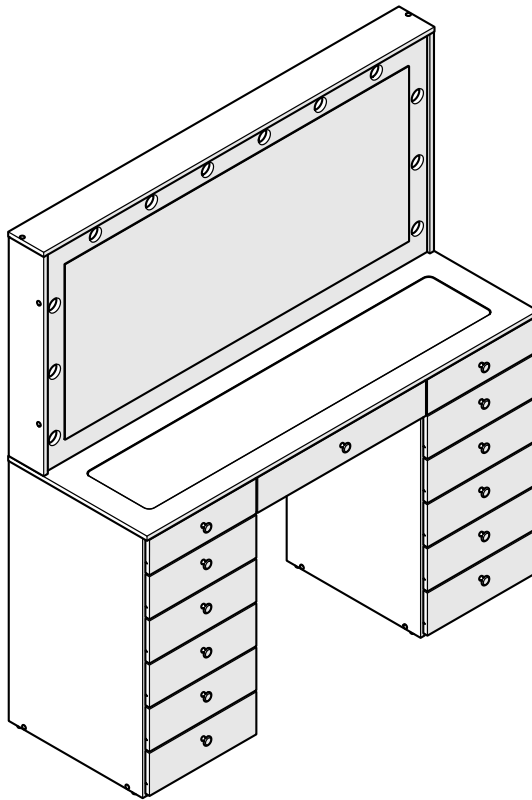

MODEL #: 1653

DRESSING TABLE WITH MIRROR

Tocador con Espejo

THIS INFORMATION BOOKLET CONTAINS IMPORTANT SAFETY INFORMATION. PLEASE READ AND KEEP FOR FUTURE REFERENCE.
ESTE FOLLETO CONTIENE INFORMACIÓN DE SEGURIDAD IMPORTANTE. POR FAVOR, LEA Y GUÁRDELO PARA REFERENCIA FUTURA.

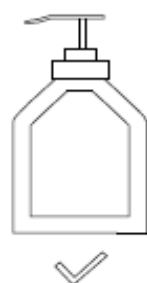
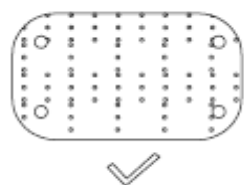

v1



To Remove the printed number, apply a small amount of Glass Cleaner or Hand sanitizer and wipe with a paper towel.

Para eliminar el número impreso, aplique una pequeña cantidad de limpiacristales o alcohol y limpie con una toalla de papel.

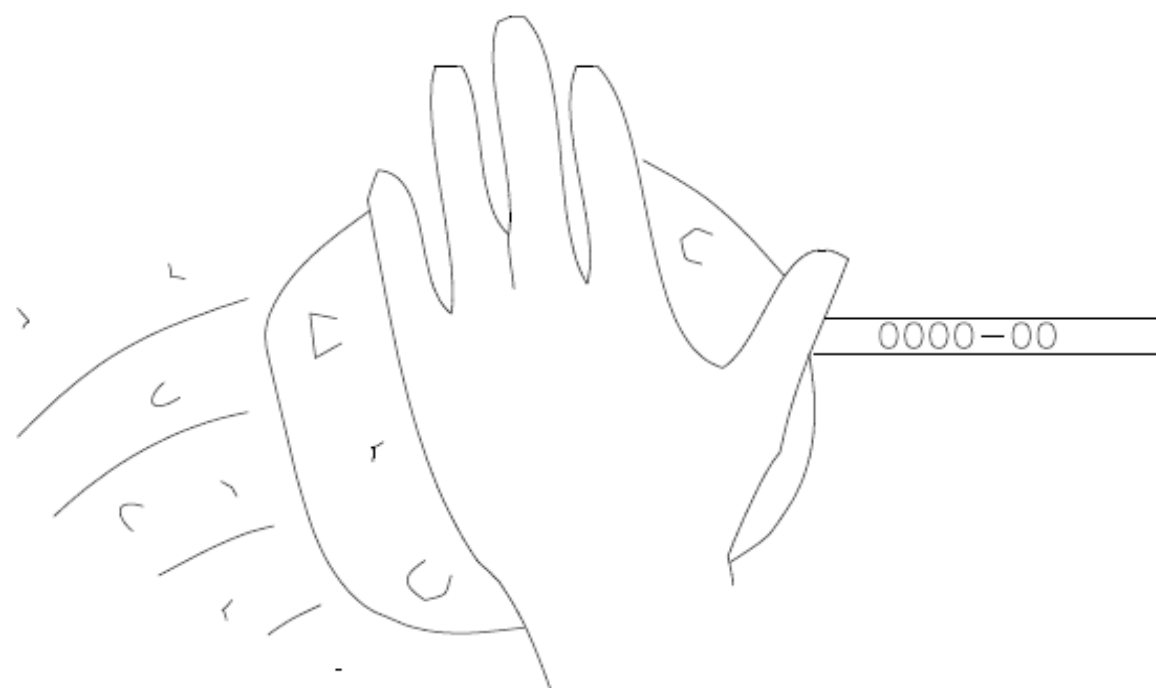

GENERAL SAFETY INFORMATION

1. Please read the Assembly Instructions prior to assembling this product.
2. Remove all the hardware from the box and sort by type.
3. Check to see that all the hardware and parts are present BEFORE assembling.
4. To avoid damage, assemble the product on a sturdy, level, and protective surface.
5. Please wait until all steps are completed before fully tightening bolts.
6. Make sure all bolts are tightly fastened before the unit is used.
7. To move the product, you must lift it. DO NOT drag it, if you drag it can cause overturning.
8. This product is sold with a hardware kit to be fixed on the wall. You must install this kit to prevent any accidents or damages. When properly installed, this restrain can provide protection against the unexpected tipping of the unit due to small tremors, bumps or climbing. The restrain is only a deterrent and is not a substitute for proper adult supervision. Use of tip-over restraints may only reduce, but not eliminate, the risk of tip-over

INFORMACIÓN GENERAL DE SEGURIDAD

1. Lea las instrucciones de armado antes de ensamblar este producto.
2. Extraiga todo el hardware de la caja y ordene por tipo.
3. Verifique que todo el hardware y las piezas están presentes ANTES de ensamblar.
4. Para evitar daños, ensamble el producto sobre una superficie resistente, nivelada y con protección.
5. Espere hasta que todos los pasos se hayan completado antes de apretar completamente los tornillos y accesorios.
6. Asegúrese de que todos los tornillos y accesorios estén bien apretados antes de usar la unidad.
7. Para mover el producto debe levantarlo. NO lo arrastre, si lo arrastra puede causar volcamiento.
8. Este producto se vende con un kit de accesorios para ser fijado en la pared. Debe instalar este kit para evitar accidentes o daños. Cuando se instala correctamente, esta restricción puede proporcionar protección contra la inclinación inesperada de la unidad debido a temblores pequeños, golpes o al treparse. La restricción es solo un elemento disuasivo y no es un sustituto de la supervisión adecuada de un adulto. El uso de restricciones de vuelco solo puede reducir, pero no eliminar, el riesgo de volcarse.



General Dimensions / Dimensiones Ge

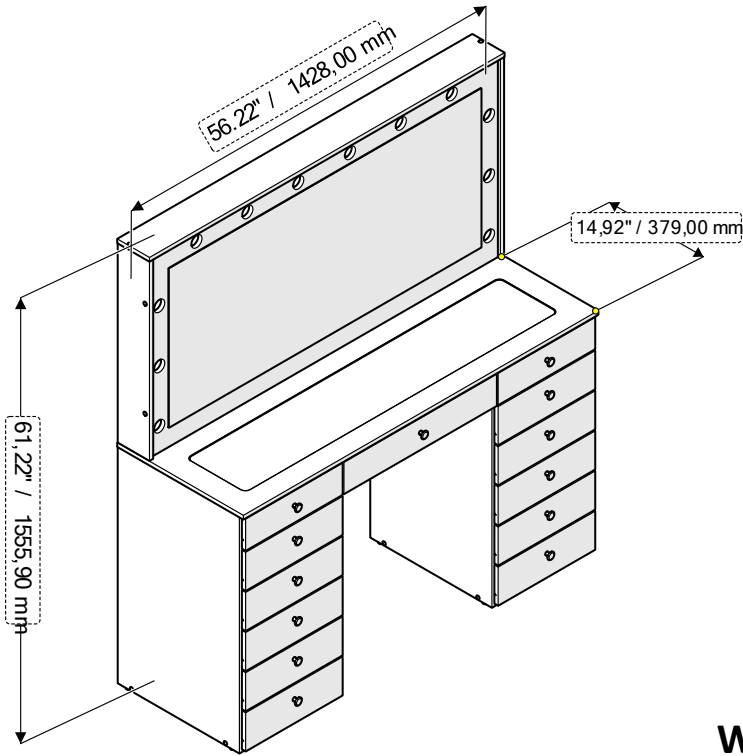

Maximum weight supported Peso máximo soportado

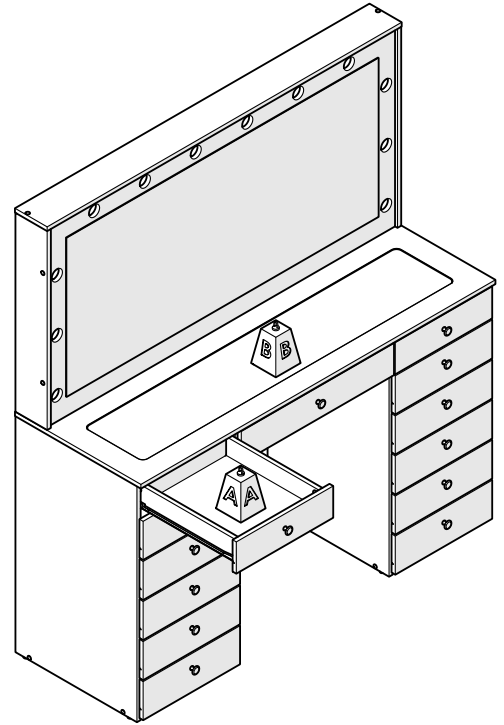

Weight in pounds. / Peso en libras.

Note: weight must be evenly distributed.

Nota: el peso debe do uniformemente.

You will need / usted necesitará:

Tools not included / herramientas no incluidas

	KG	LB
A	6	13.23
B	5	11.02

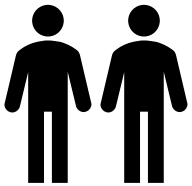

Recommended space for assemble
Espacio recomendado para el armado

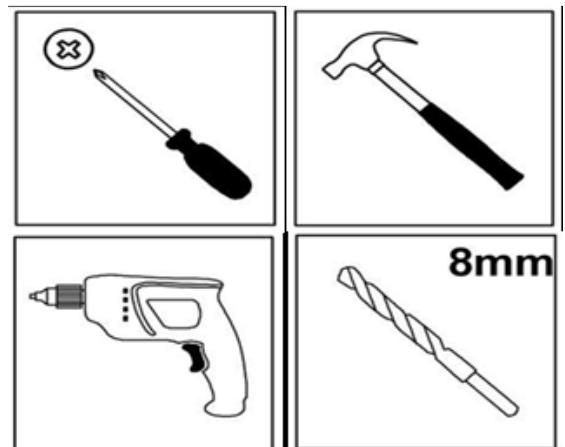
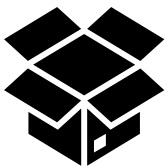

INSTALACIÓN DE LA LEVA

Identifique la flecha en la cabeza de la leva. La flecha debe apuntar hacia el agujero en el borde del panel. Empuje la leva hasta el fondo del orificio.

INSTALLING CAM

Identify arrow on head of cam. Arrow MUST point toward hole in edge of panel. Push cam all the way down into hole.

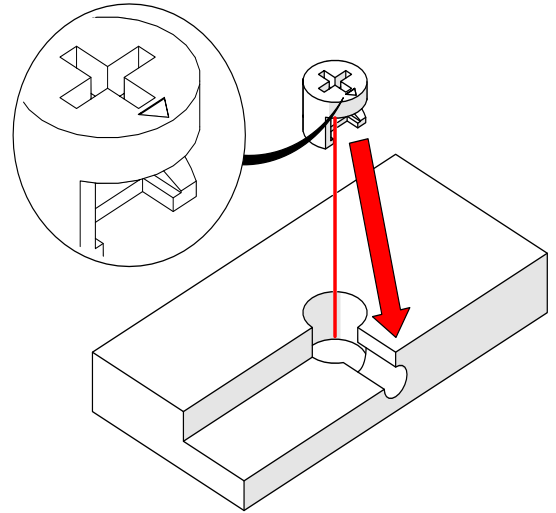
**ALINEACIÓN DE LA LEVA Y EL PASADOR**

Asegúrese de que la flecha de la leva apunte hacia el orificio e inserte la clavija de la leva en el orificio. Asegúrese de que las piezas se unen.

CAM AND DOWEL ALIGNMENT

Ensure the arrow on the cam points toward hole and insert cam dowel into hole. Make sure pieces join together.

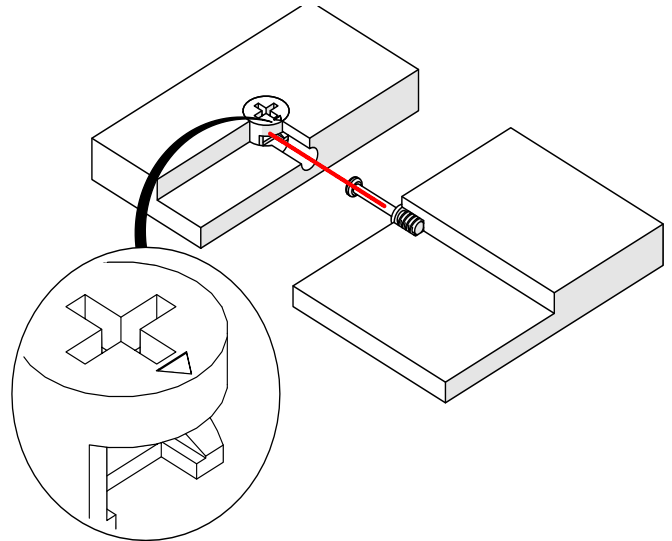
**APRIETE DE LA LEVA**

Utilice un destornillador para girar la leva. Gire la leva (en el sentido de las agujas del reloj) hasta que esté completamente apretada. Un poco más de media vuelta.

TIGHTENING CAM



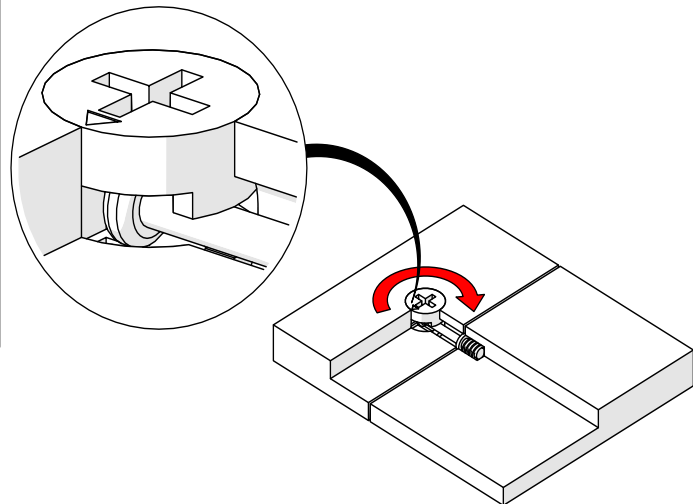



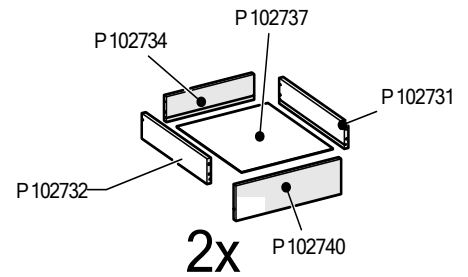
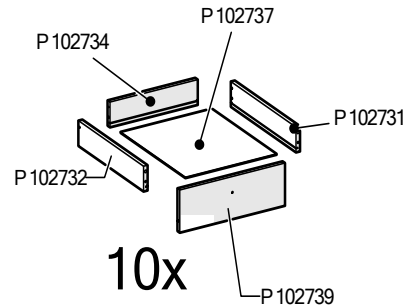
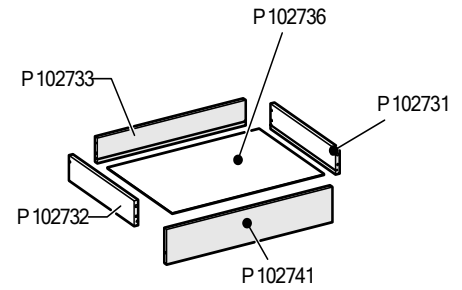
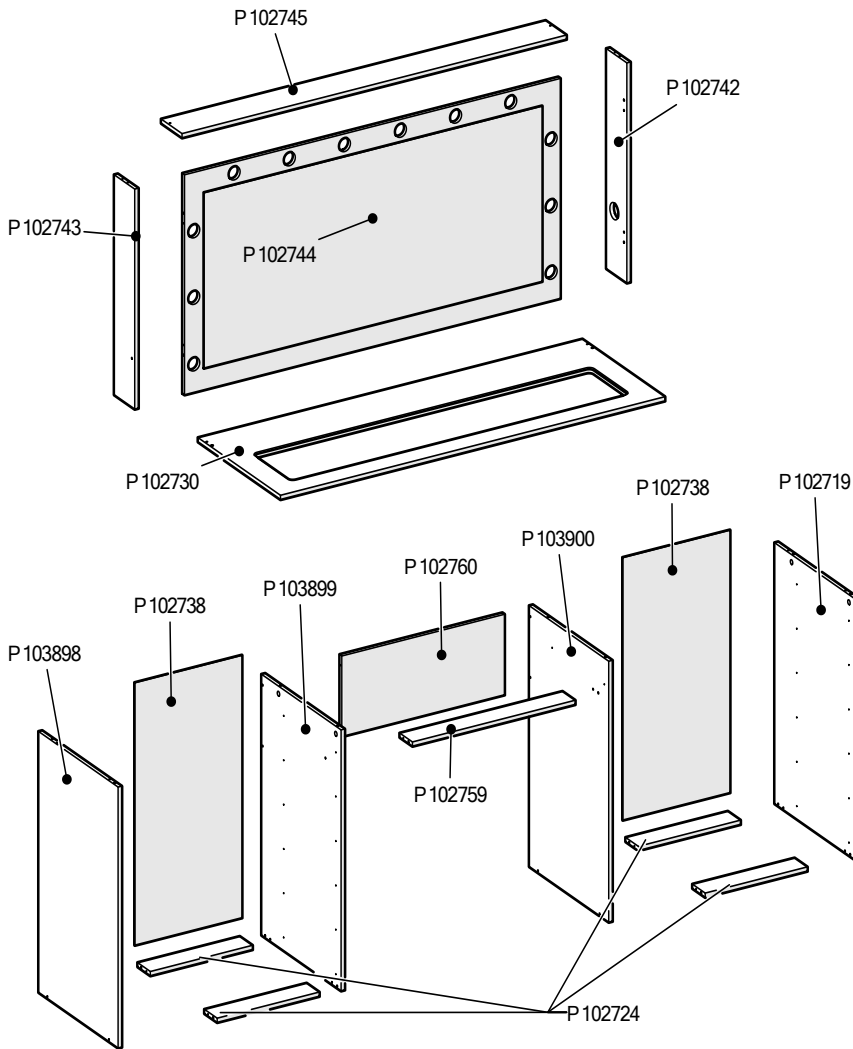

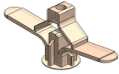

Use screwdriver to turn cam. Turn cam (clockwise) until fully tightened. Slightly more than half a turn.

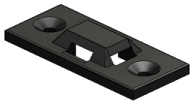

QTD.	CODIGO CODE	Descripción	Description	C x L x E	L x W x T
1	P102719	LADO DERECHA	RIGHT SIDE	825 x 490 x 15 mm	32.48 x 19.29 x 0.59 in
4	P102724	ZOCALO	BASEBOARD	381 x 80 x 15 mm	15.00 x 3.15 x 0.59 in
1	P102730	TAPA	TOP	1430 x 508 x 15 mm	56.30 x 20.00 x 0.59 in
13	P102731	LADO DERECHO DEL CAJÓN	RIGHT DRAWER SIDE	400 x 80 x 15 mm	15.75 x 3.15 x 0.59 in
13	P102732	LADO ESQUIERDO DEL CAJÓN	LEFT DRAWER SIDE	400 x 80 x 15 mm	15.75 x 3.15 x 0.59 in
1	P102733	CABEZAL DEL CAJÓN	DRAWER HEAD	551 x 80 x 15 mm	21.69 x 3.15 x 0.59 in
12	P102734	CABEZAL DEL CAJÓN	DRAWER HEAD	326 x 80 x 15 mm	12.83 x 3.15 x 0.59 in
1	P102736	FONDO DEL CAJÓN	DRAWER BOTTOM	564 x 398 x 3 mm	22.20 x 15.67 x 0.12 in
12	P102737	FONDO DEL CAJÓN	DRAWER BOTTOM	339 x 398 x 3 mm	13.35 x 15.67 x 0.12 in
2	P102738	PANEL TRASERO	REAR PANEL	830 x 400 x 3 mm	32.68 x 15.75 x 0.12 in
10	P102739	FRENTE DEL CAJÓN	DRAWER FRONT	391 x 135 x 15 mm	15.39 x 5.31 x 0.59 in
2	P102740	FRENTE DEL CAJÓN	DRAWER FRONT	391 x 111 x 15 mm	15.39 x 4.37 x 0.59 in
1	P102741	FRENTE DEL CAJÓN	DRAWER FRONT	616 x 111 x 15 mm	24.25 x 4.37 x 0.59 in
1	P102742	LADO DERECHA	RIGHT SIDE	696 x 128 x 15 mm	27.40 x 5.04 x 0.59 in
1	P102743	LADO ESQUIERDA	LEFT SIDE	696 x 128 x 15 mm	27.40 x 5.04 x 0.59 in
1	P102744	PIEZA DEL ESPEJO	MIRROR PART	1398 x 696 x 15 mm	55.04 x 27.40 x 0.59 in
1	P102745	SOMBRERO	HAT	1430 x 130 x 15 mm	56.30 x 5.12 x 0.59 in
1	P102759	TRAVESANO	PLATTER	606 x 80 x 15 mm	23.86 x 3.15 x 0.59 in
1	P102760	REFORZAMIENTO	REINFORCEMENT	606 x 256 x 15 mm	23.86 x 10.08 x 0.59 in
2	P102861	COSTA	COAST	740 x 90 x 3 mm	29.13 x 3.54 x 0.12 in
1	P103898	LADO ESQUIERDA	LEFT SIDE	825 x 490 x 15 mm	32.48 x 19.29 x 0.59 in
1	P103899	DIVISION	DIVISION	825 x 490 x 15 mm	32.48 x 19.29 x 0.59 in
1	P103900	DIVISION	DIVISION	825 x 490 x 15 mm	32.48 x 19.29 x 0.59 in

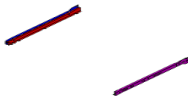

	QTD.	CDIGO CODE	Descripción	Description
	1	000041	SOBRE DE COLA	GLUE
	48	000107	CLAVO 10 X 10	NAIL 10 X 10
	9	000108	CLAVO 12 X 12	NAIL 12 X 12
	4	000899	CANTONERA	PLASTIC SUPPORT
	2	001178	TORNILLO 3,5 X 16	SCREW 3,5 X 16
	70	001802	TARUGO 6X30MM	DOWEL 6X30MM
	9	001901	ZAPATO 15 X 6	SHOE 15 X 6
	2	001925	TARUGO 6 X 50MM	DOWEL 6 X 50MM
	120	004214	TORNILLO 3,5 X 14MM	SCREW 3,5 X 14MM
	27	005256	TORNILLO PLANO 4,0 X 20 BC	FLAT SCREW 4,0 X 20
	27	018458	SOPORTE TRIANGULO	TRIANGLE SUPPORT
	35	030945	TORNILLO DE ACERO PARA MINIFIX	STEEL SCREW FOR MINIFIX
	35	030950	CILINDRO 15MM	BARREL 15MM

	2	032069	CASQUILLO DE FIJACION PARA YESO	FIXING BUSHING FOR PLASTER
	2	051980	TORNILLO 4,5 X 50	SCREW 4,5 X 50 BC
	2	055606	SOPORTE DE FIJACIÓN	FIXATION SUPPORT
	1	055607	ABRACADEIRA NYLON 300 MM	NYLON CLAMP 300MM
	1	058788	LLAVE ALLEN	ALLEN WRENCH
	13	062448	TIRADOR DE PUERTA	DOOR HANDLE
	1	068810	ESPEJO 1258 X 555 X 3MM	MIRROR 1258 X 555 X 3MM
	1	068811	VIDRIO INCOLOR 1258x235x4MM	COLORLESS GLASS 1258x235x4MM
	1	068915	DIVISOR DE CAJONES	DRAWER DIVIDER
	49	075515	TORNILLO 5 X 40	SCREW 5 X 40
	13	CRM400	CORREDERA METALICA 400MM	METALIC SLIDE 400MM
	46	13MM	TAPA DEL AGUJERO 13MM	SCREW CAP COVER 13MM
	34	19MM	TAPA DEL AGUJERO 19MM	SCREW CAP COVER 19MM



ATTENTION

To facilitate the assembly process, separate and organize all boards before you start.



Para facilitar el armado, separa y organiza todas las tablas antes de empezar.

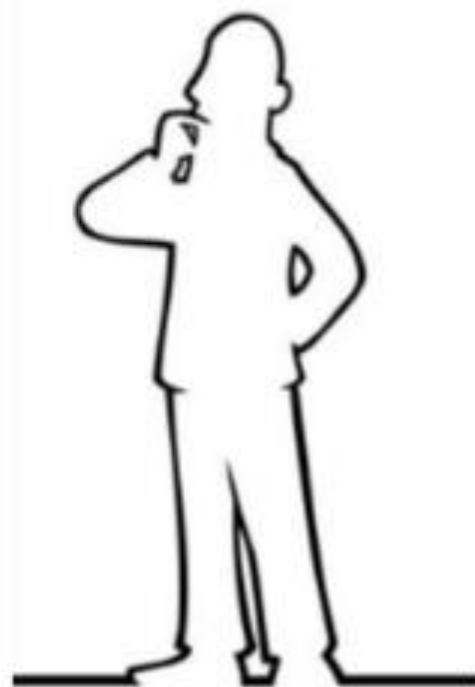

PASO / STEP 1

Fix **wooden dowel** (001802), **metallic right slide** (CRM400) and **plastic foot** (001901) to **right side** (P102719).
 Fijar **pin** (001802), **corredera lateral derecha** (CRM400) y **pie plástico** (001901) a **lateral derecho** (P102719).

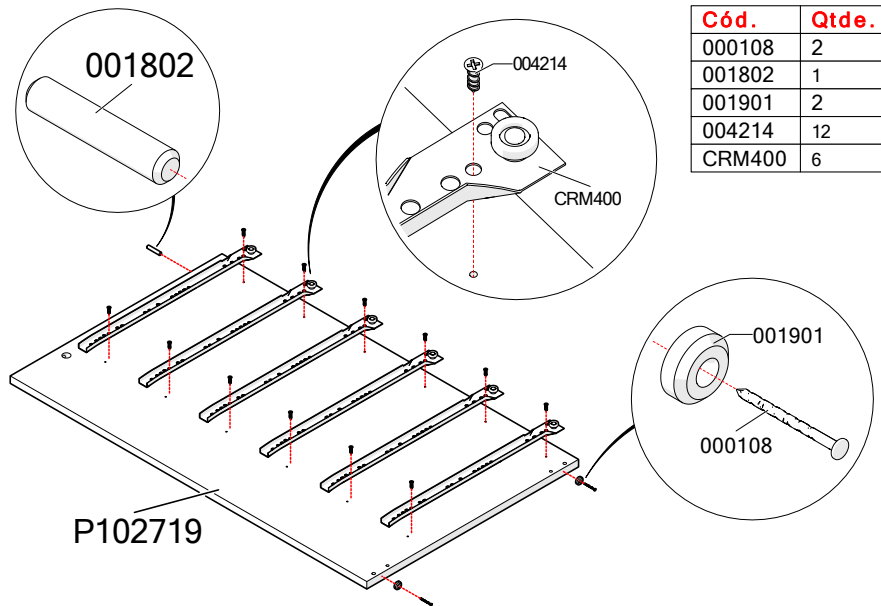

Cód.	Qtde.
000108	2
001802	1
001901	2
004214	12
CRM400	6

PASO / STEP 2

Fix **wooden dowel** (001802) and **Baseboard** (P102724) x4.
 Fijar **pin** (001802) y **zócalo** (P102724) x4.

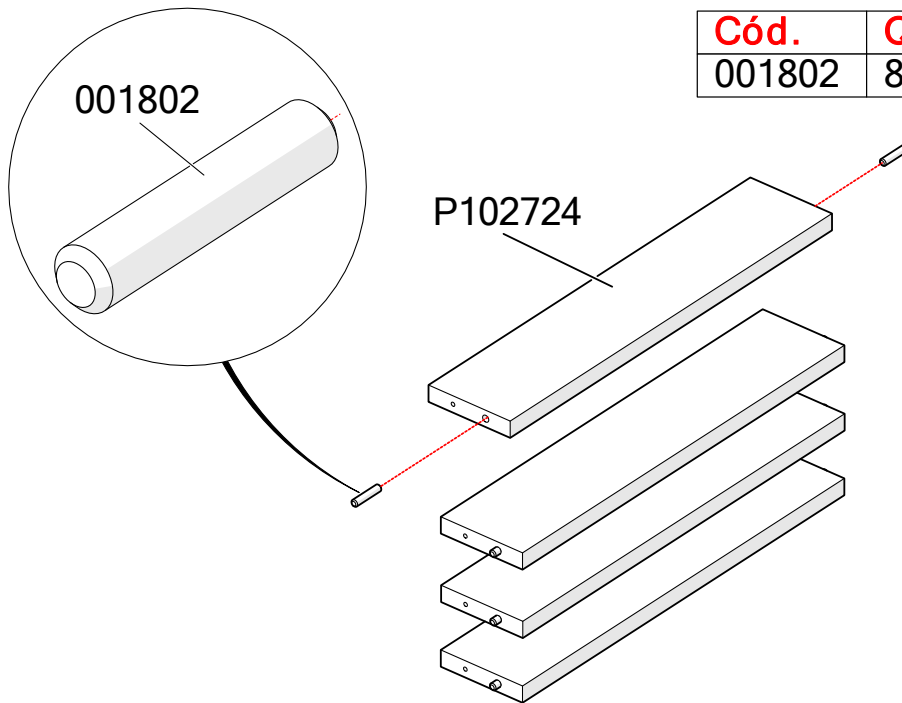

Cód.	Qtde.
001802	8

PASO / STEP 3

Fix **simple minifix screw (030945)** to **top base (P102730)**.

Fijar **tornillo minifix simple (030945)** a **base superior (P102730)**.

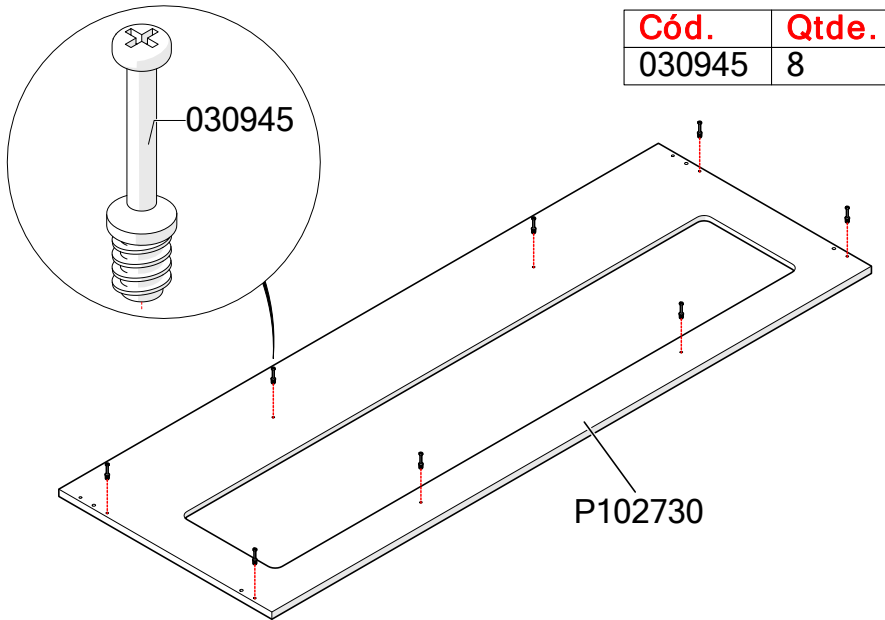

PASO / STEP 4

Fix the **wood pin (001802)** in the **Mirror (P102744)**

Fije **Pin (001802)** en la **Espejo (P102744)**

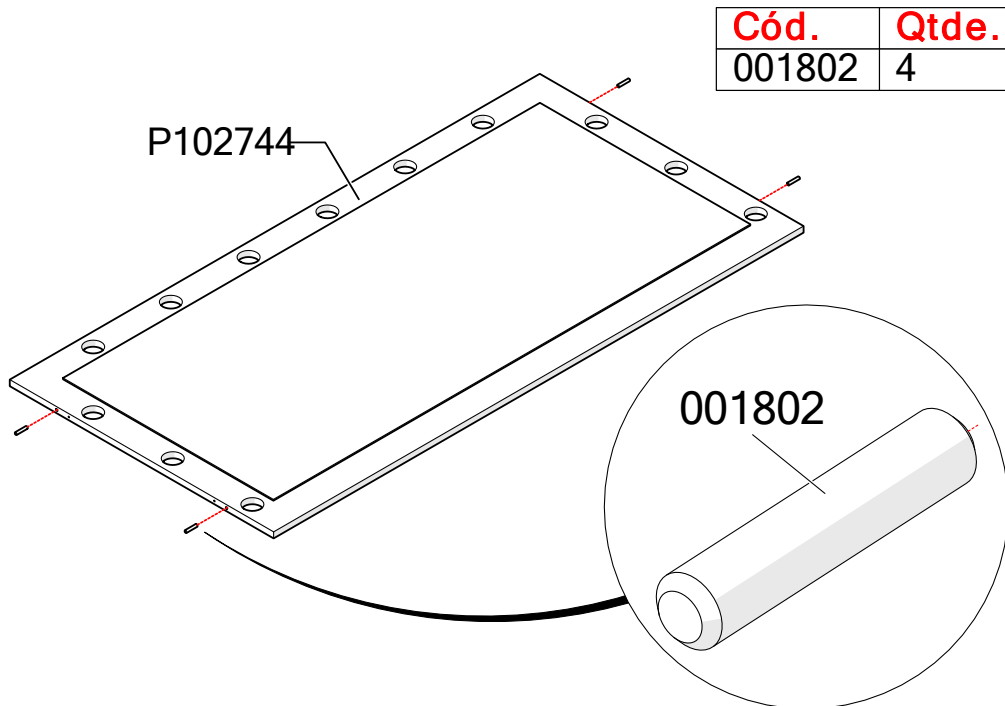

PASO / STEP 5

Fix **wooden dowel (001802)** to **crossbeam (P102759)**.

Fijar **pin (001802)** a **travesaño (P102759)**.

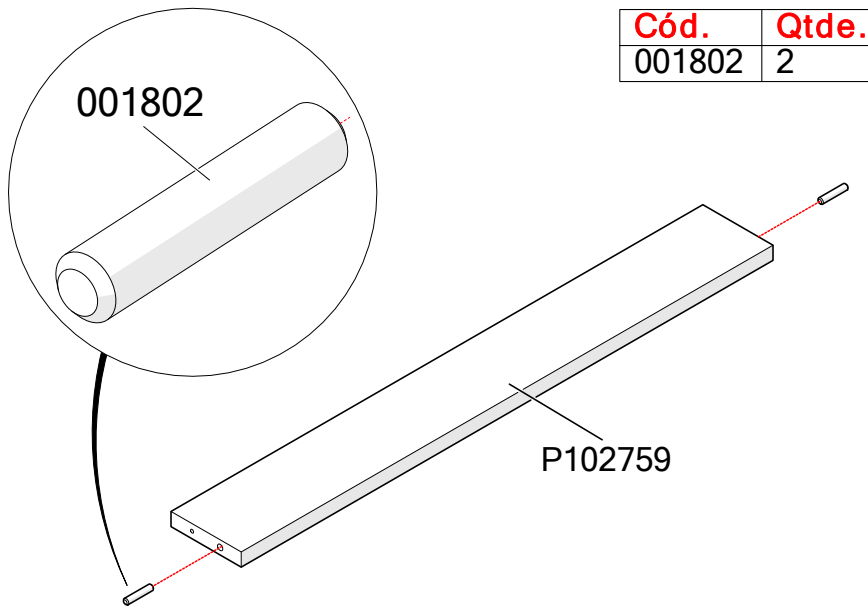

Cód.	Qtde.
001802	2

PASO / STEP 6

Fix **wooden dowel (001802)**, **metallic left slide (CRM400)** and **plastic foot (001901)** to **left side (P103898)**.

Fijar **pin (001802)**, **corredera lateral izquierda (CRM400)** y **pie plástico (001901)** a **lateral izquierda (P103898)**.

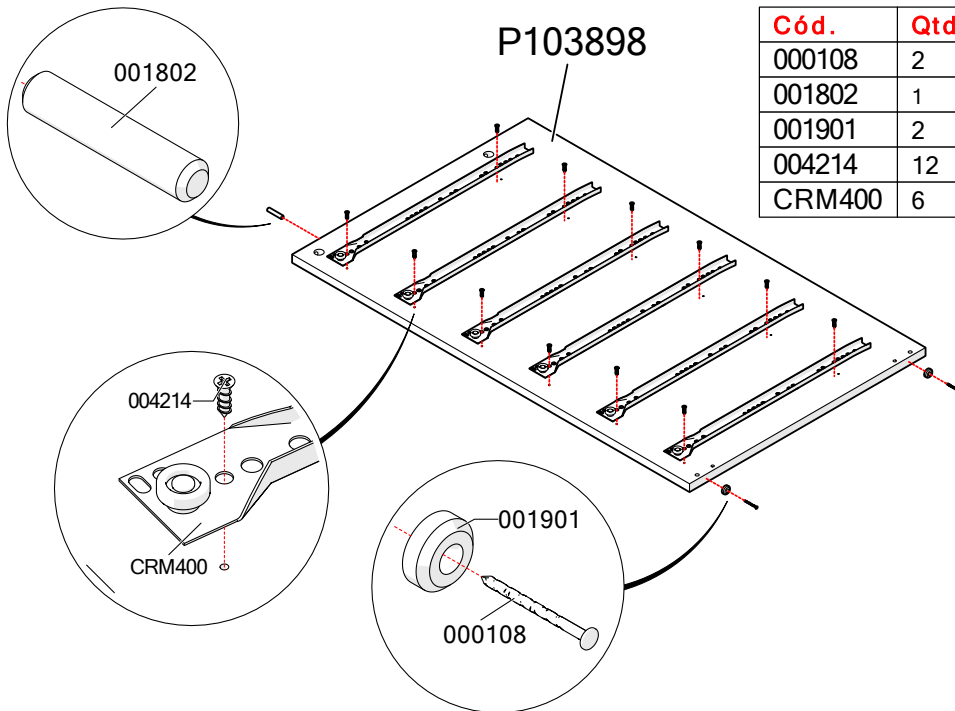

Cód.	Qtde.
000108	2
001802	1
001901	2
004214	12
CRM400	6

PASO / STEP 7

Fix **metallic slide** (CRM400) to **right division** (P103900) and **plastic foot** (001901).

Fijar **corredera lateral** (CRM400) a **división derecha** (P103900) y fijar **pie de plástico** (001901).

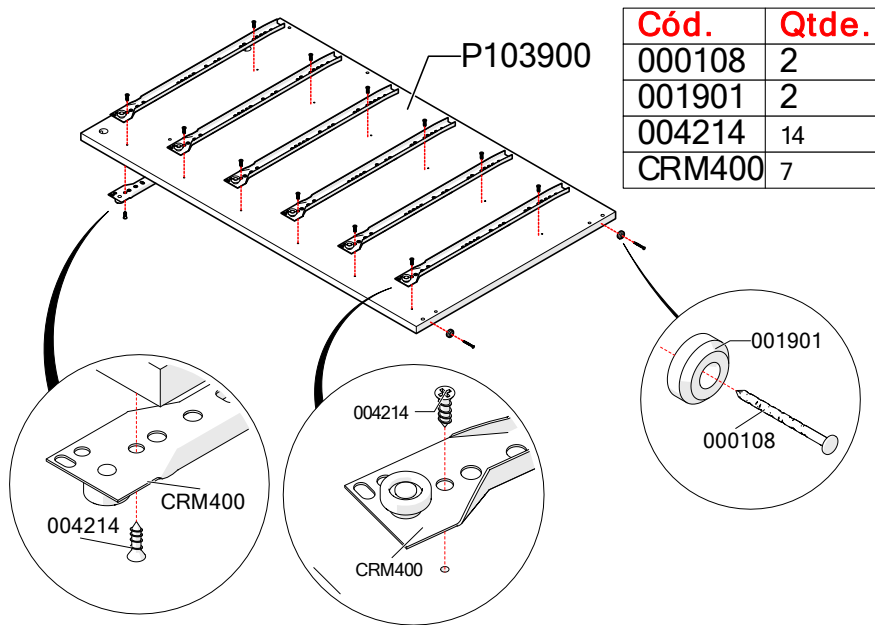

Cód.	Qtde.
000108	2
001901	2
004214	14
CRM400	7

PASO / STEP 8

Fix **metallic slide** (CRM400) to **division** (P103899) and **plastic foot** (001901).

Fijar **corredera lateral** (CRM400) a **división** (P103899) y fijar **pie de plástico** (001901).

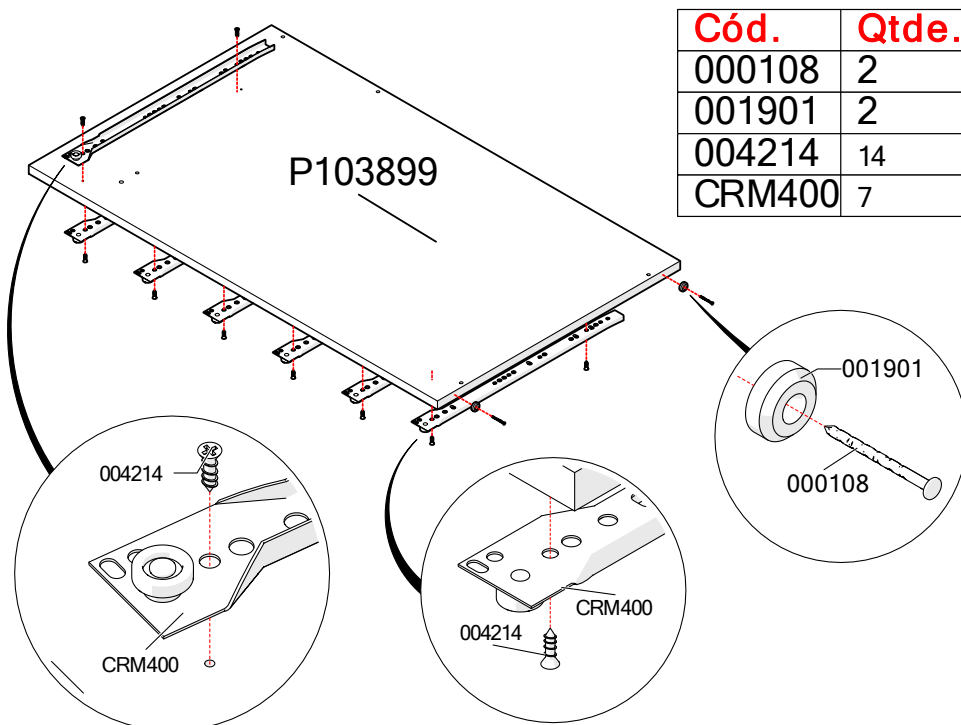

Cód.	Qtde.
000108	2
001901	2
004214	14
CRM400	7

PASO / STEP 9

Fix **wooden dowel** (001802) to **right drawer side** (P102731) x13.

Fije **pin** (P001802) al **lado derecho del cajón** (P102731) x13.

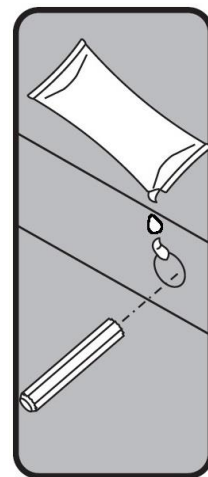
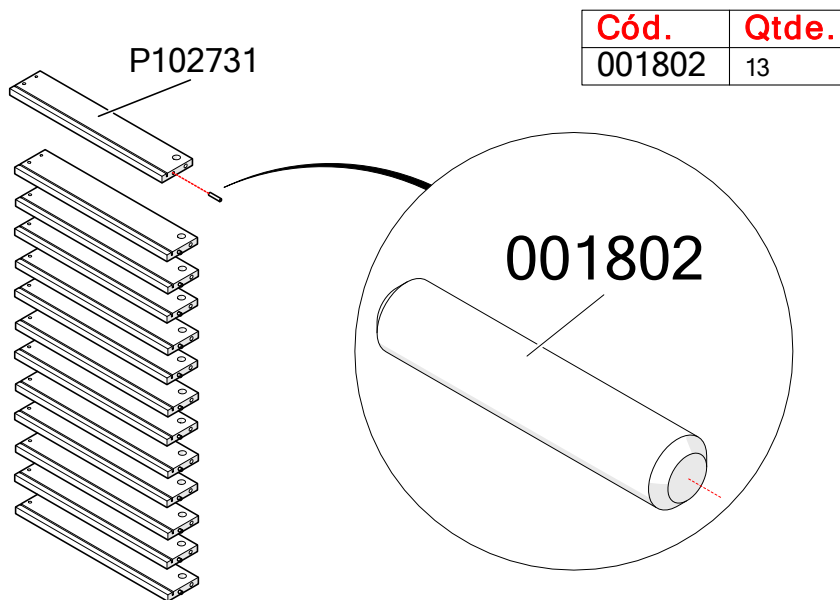

PASO / STEP 10

Fix **wooden dowel** (001802) to **left drawer side** (P102732) x13.

Fije **pin** (P001802) al **lado izquierdo del cajón** (P102732) x13.

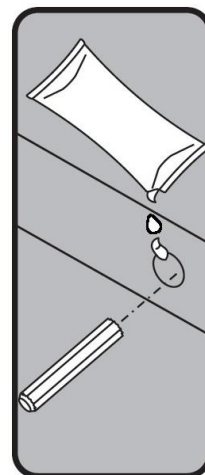
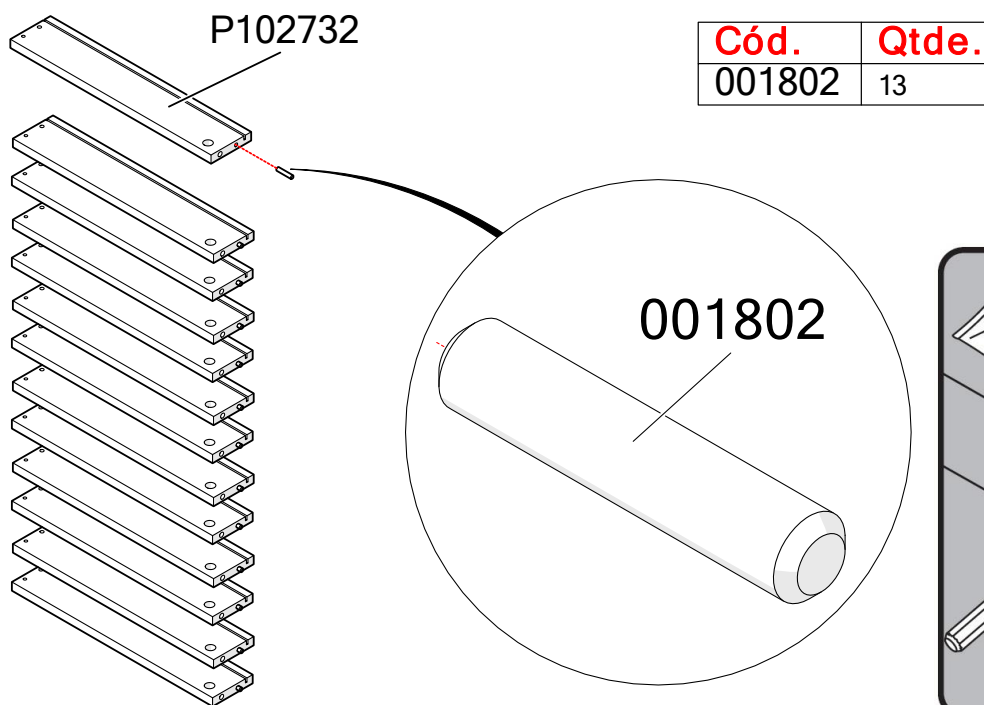

PASO / STEP 11

Fix **wooden dowel (001802)** to **back of drawer (P102734)** x12.

Fije el **pin (001802)** al **posterior de cajón (P102734)** x12.

P102734

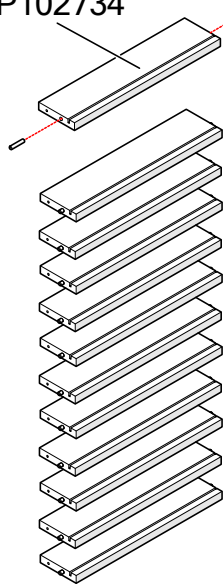

Cód.	Qtde.
001802	24

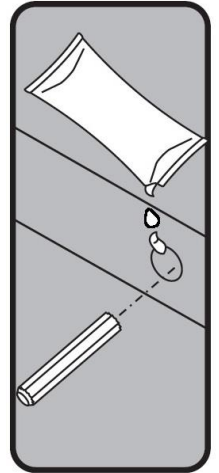
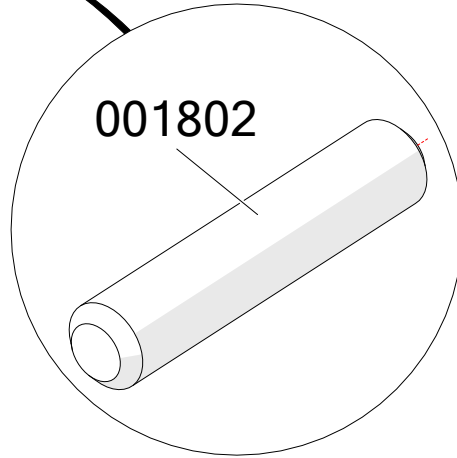

PASO / STEP 12

Fix **wooden dowel (001802)** to **back of drawer (P102733)**

Fije el **pin (001802)** al **posterior de cajón (P102733)**

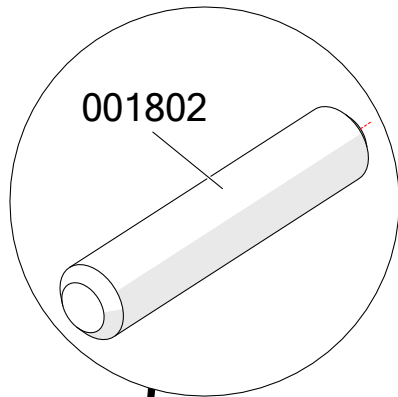

Cód.	Qtde.
001802	2

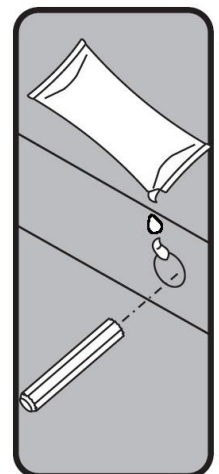
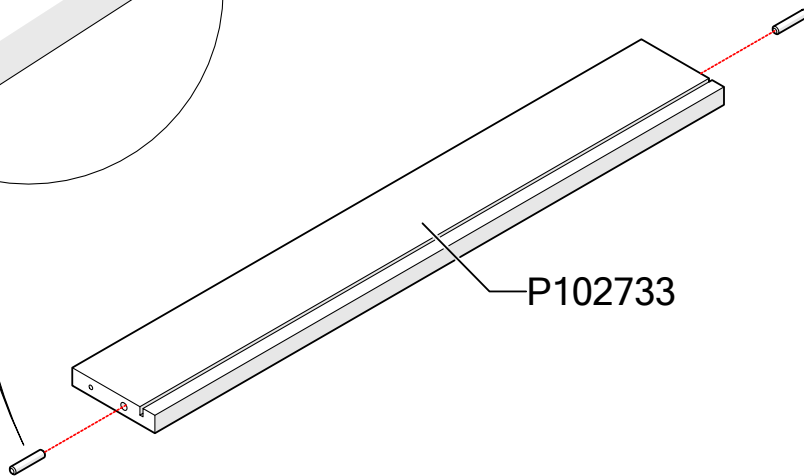

PASO / STEP 13

Fix *simple minifix screw (030945)* to *front of Drawer (P102739)* x10.

Fijar *tornillo minifix simple (030945)* a *frente de cajón (P102739)* x10

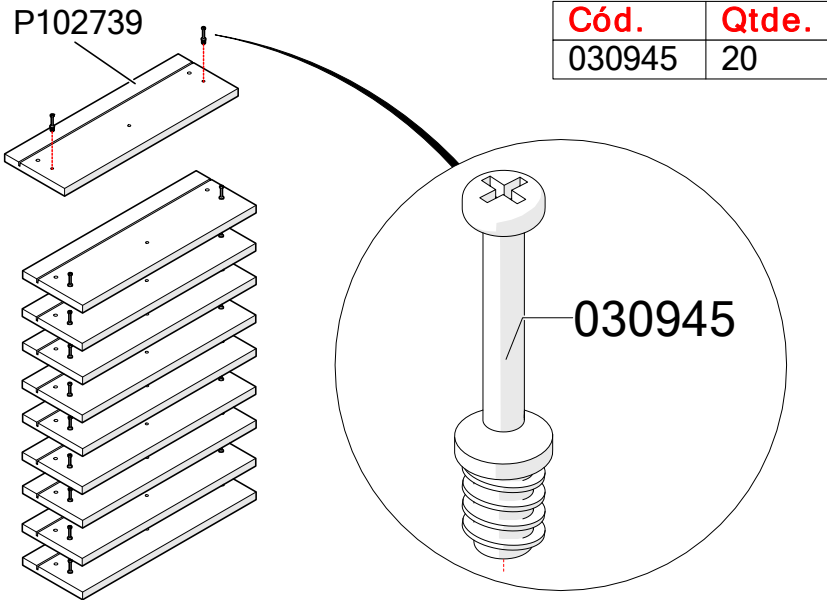

PASO / STEP 14

Fix *simple minifix screw (030945)* to *front of Drawer (P102740)* x2.

Fijar *tornillo minifix simple (030945)* a *frente de cajón (P102740)* x2

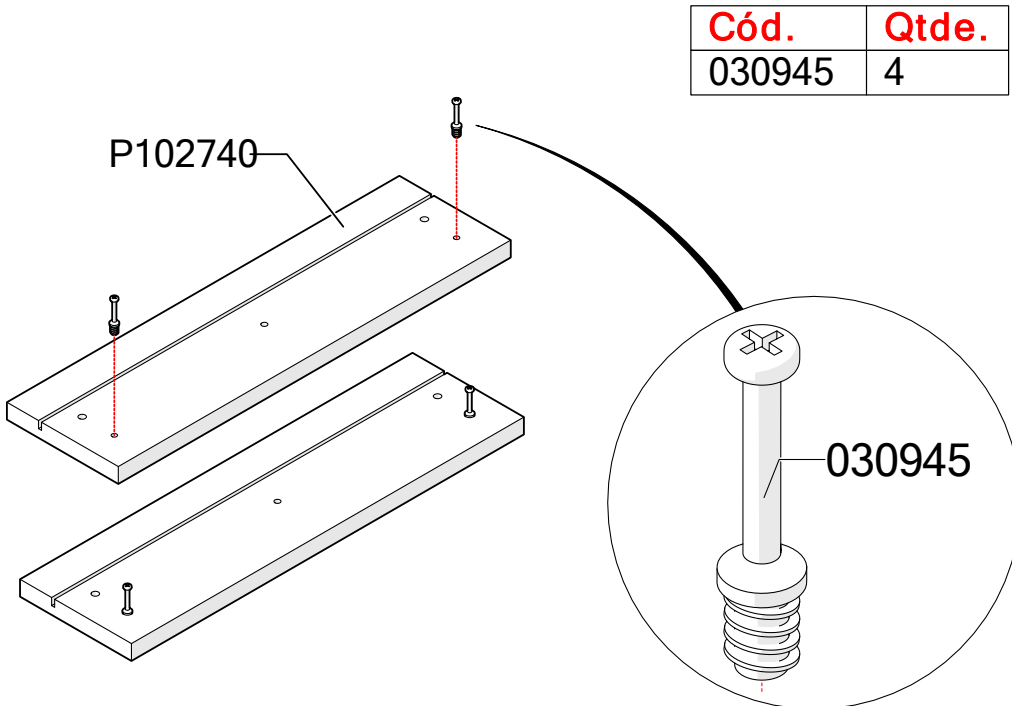

PASO / STEP 15

Fix **simple minifix screw (030945)** to **front of Drawer (P102740)** .

Fijar **tornillo minifix simple (030945)** a **frente de cajón (P102740)** .

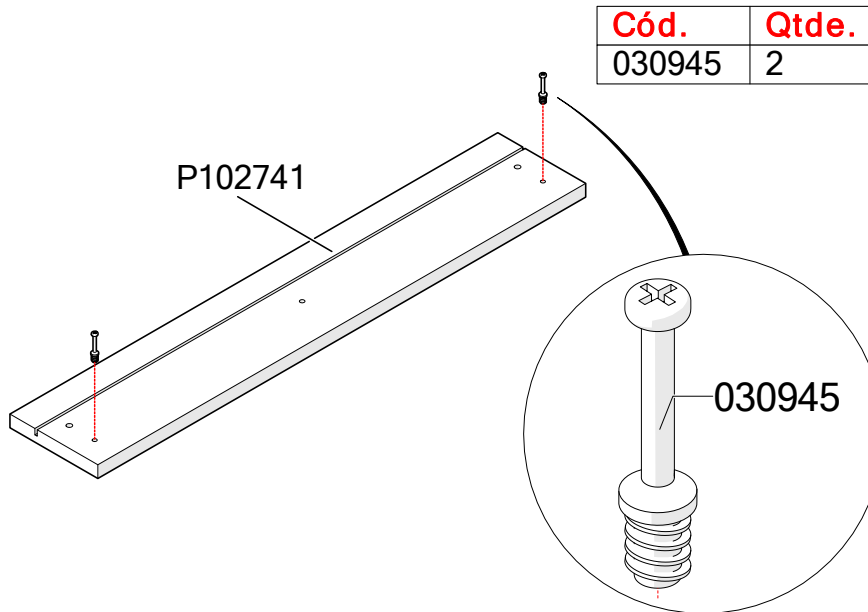

PASO / STEP 16

Fix **wooden dowel (001802)** and **larger wooden dowel (001925)** to **Upper right side (P102742)**.

Fijar **pin (001802)** y **pin mayor (001925)** **Parte superior derecha (P102742)**.

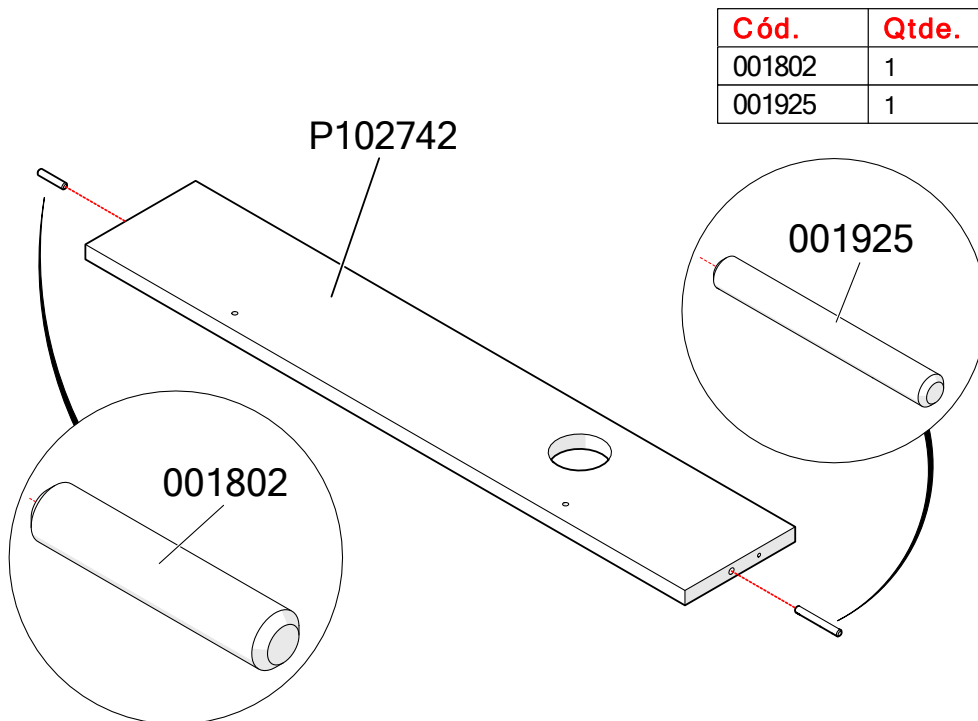

PASO / STEP 17

Fix **wooden dowel (001802)** and **larger wooden dowel (001925)** to **Upper leftt side (P102743)**.
Fijar **pin (001802)** y **pin mayor (001925)** Parte superior izquierda (P102743).

Cód.	Qtde.
001802	1
001925	1

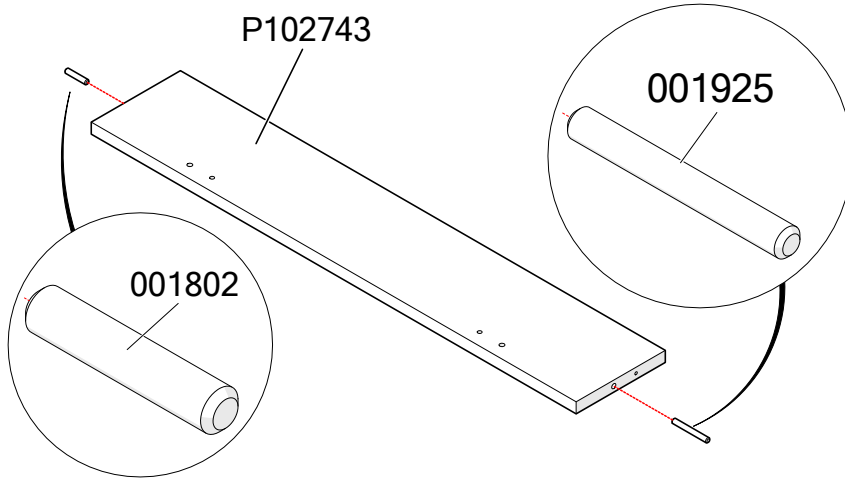

PASO / STEP 18

Fix **side tray (P102742/P102743)** to **mirror (P102744)**.

Fijar **travesaño lateral (P102742/P102743)** a **espejo (P102744)**.

Cód.	Qtde.
058788	1
075515	4
13MM	4

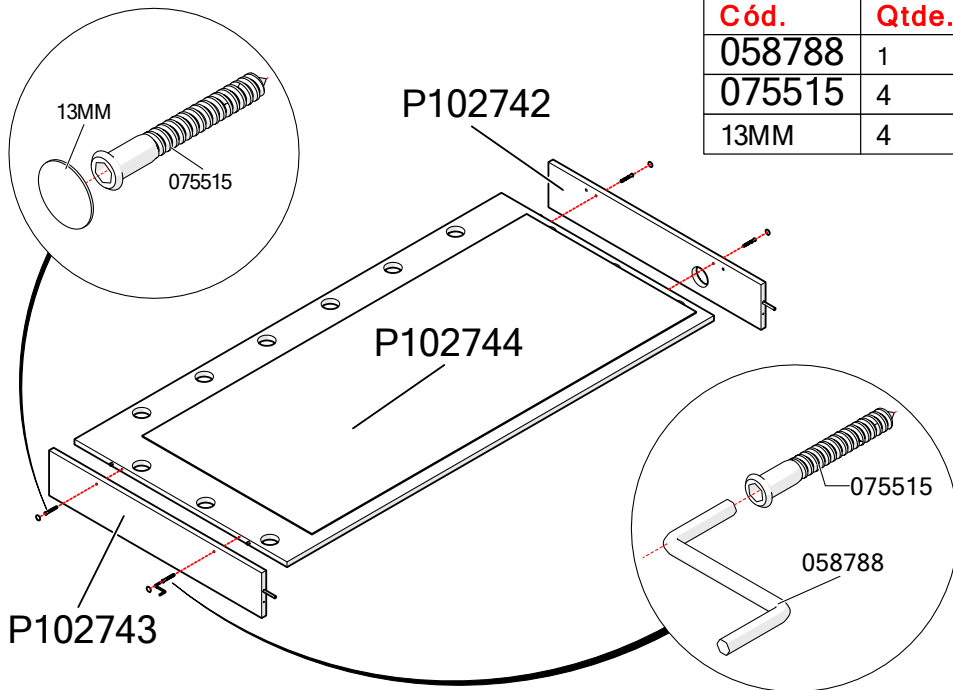

PASO / STEP 19

Fix **top tray** (P102745) to previous assembly.

Fijar **travesaño superior** (P102745) a ensamble previo.

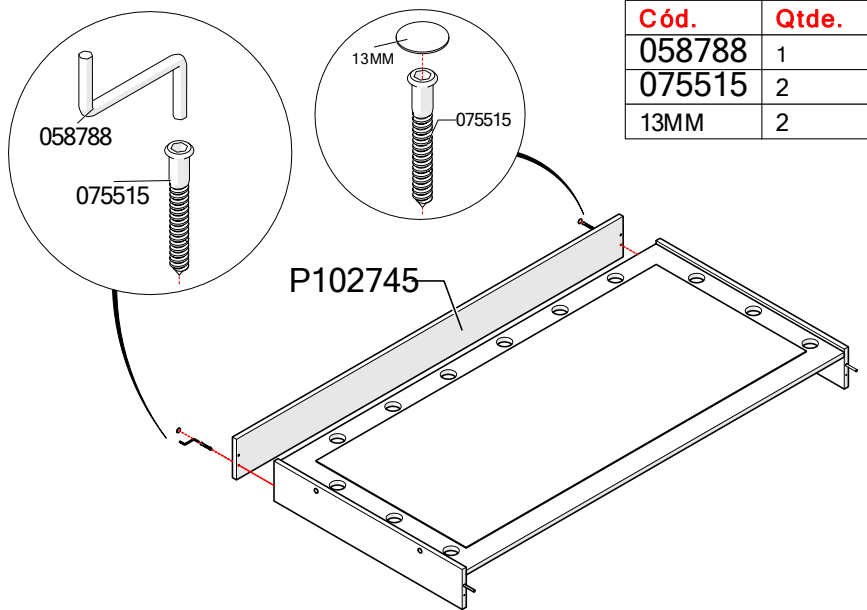

PASO / STEP 20

Fix **top base** (P102730) to previous assembly.

Fijar **base superior** (P102730) a ensamble previo.

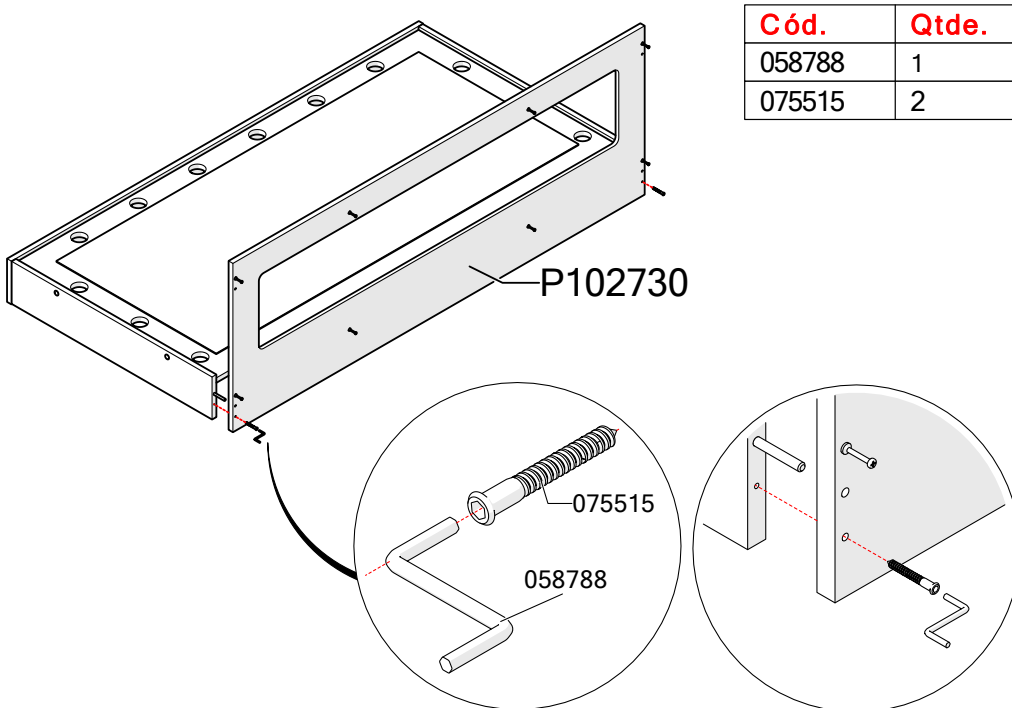

PASO / STEP 21

Fix **crossbar (P102759)** and **bases (P102724)** to the **partition (P103899/P103900)** and **bottom (P102760)**.

Fije el **travesaño (P102759)** y las **bases (P102724)** a la división (**P103899/P103900**) y **fondo (P102760)**.

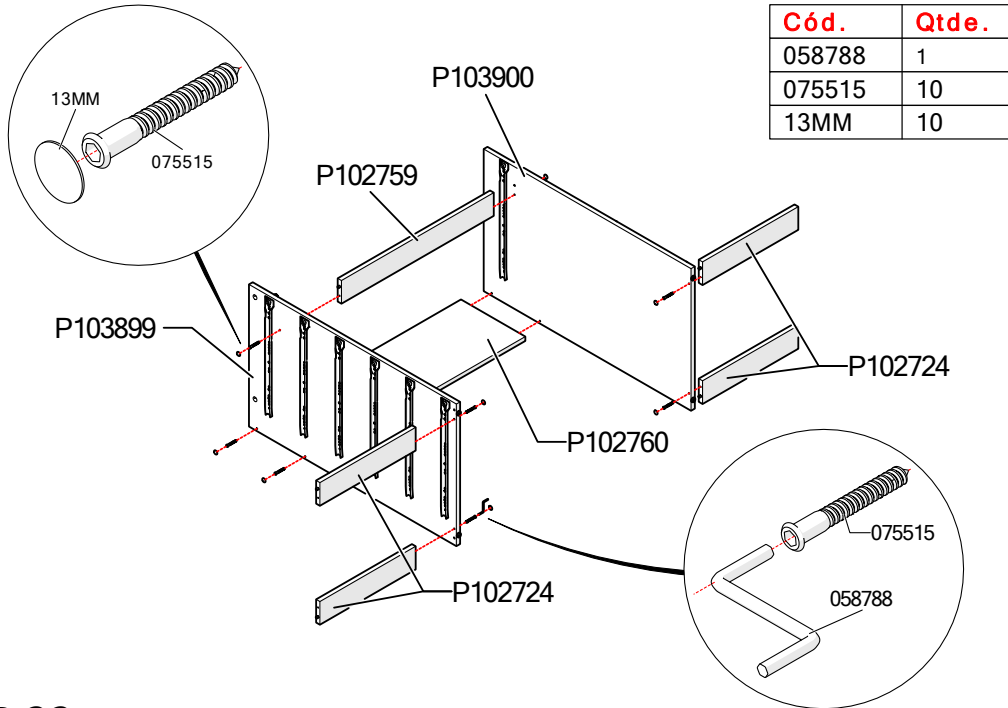

Cód.	Qtde.
058788	1
075515	10
13MM	10

PASO / STEP 22

Fix the **sides (P102719/P103898)** to the **previous assembly**.

Fije los **laterales (P102719/P103898)** al conjunto anterior.

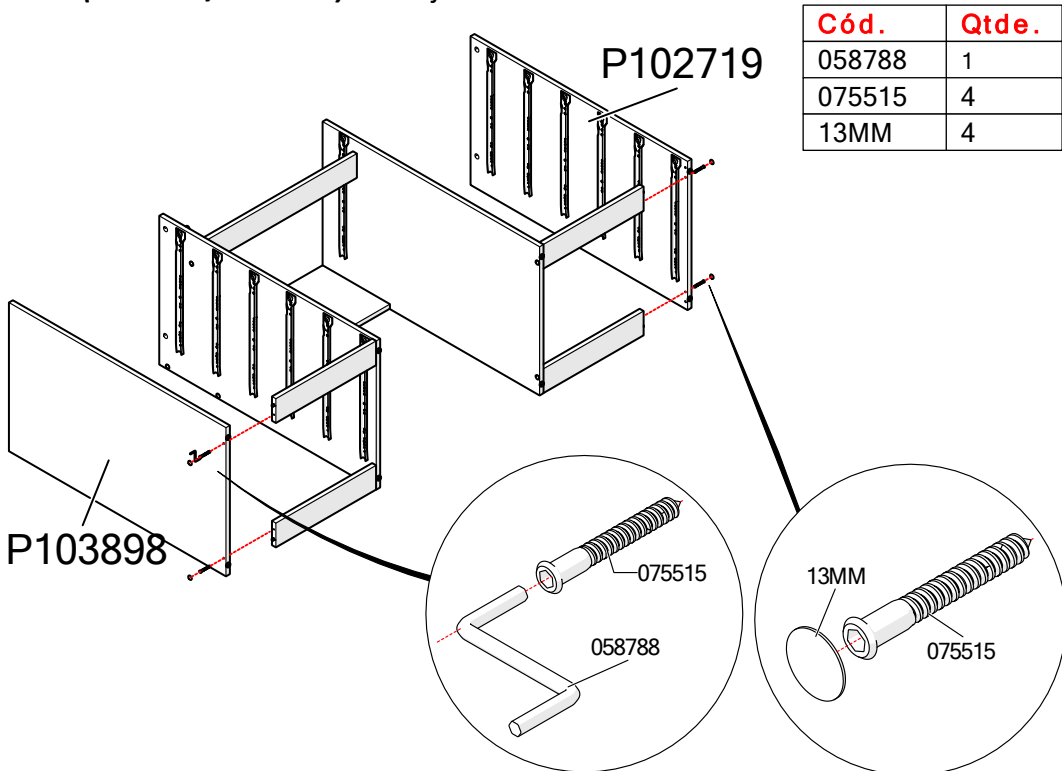

Cód.	Qtde.
058788	1
075515	4
13MM	4

PASO / STEP 23

Fix both pre-assemblies 20 and 22.

Fijar ambos ensambles previos 20 y 22.

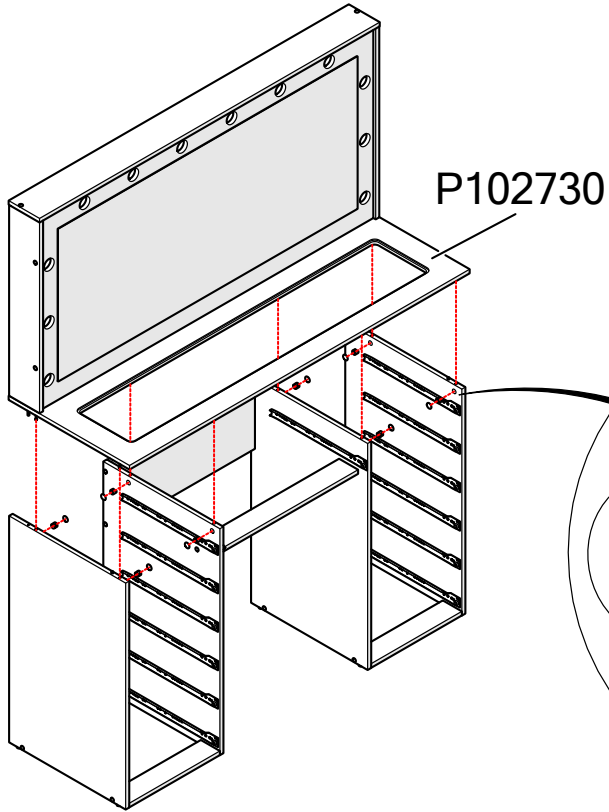

Cód.	Qtde.
030950	8
19MM	8

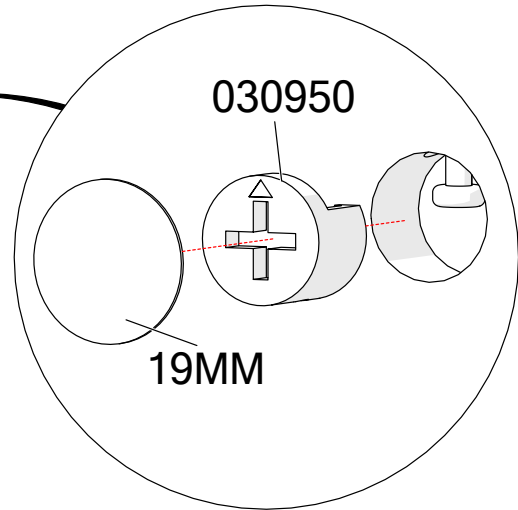

PASO / STEP 24

Attach the **plastic bracket (000899)** to the top assembly.
Fije el **soporte de plástico (000899)** al conjunto superior.

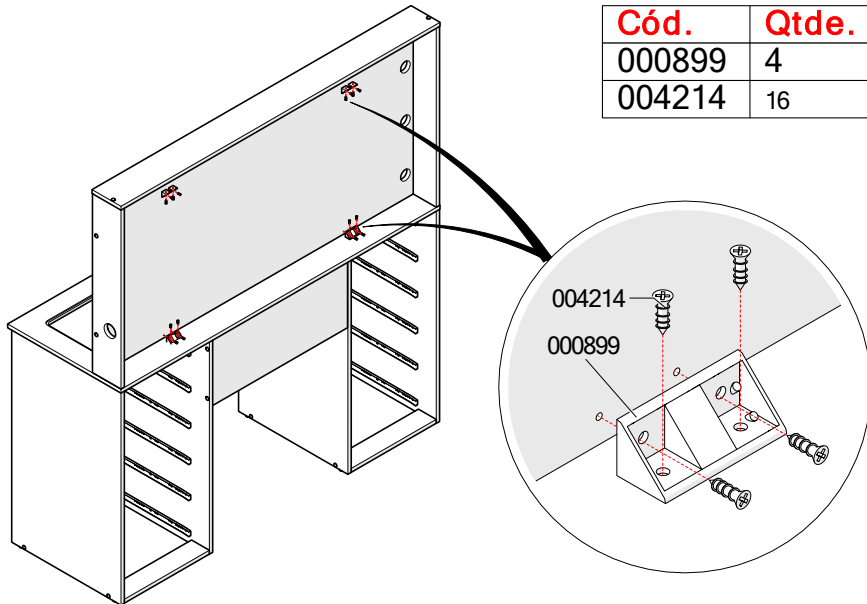

PASO / STEP 25

Fix **backboard (P102738)** to previous assembly.

Fijar **fondo (P102738)** a ensamble previo.

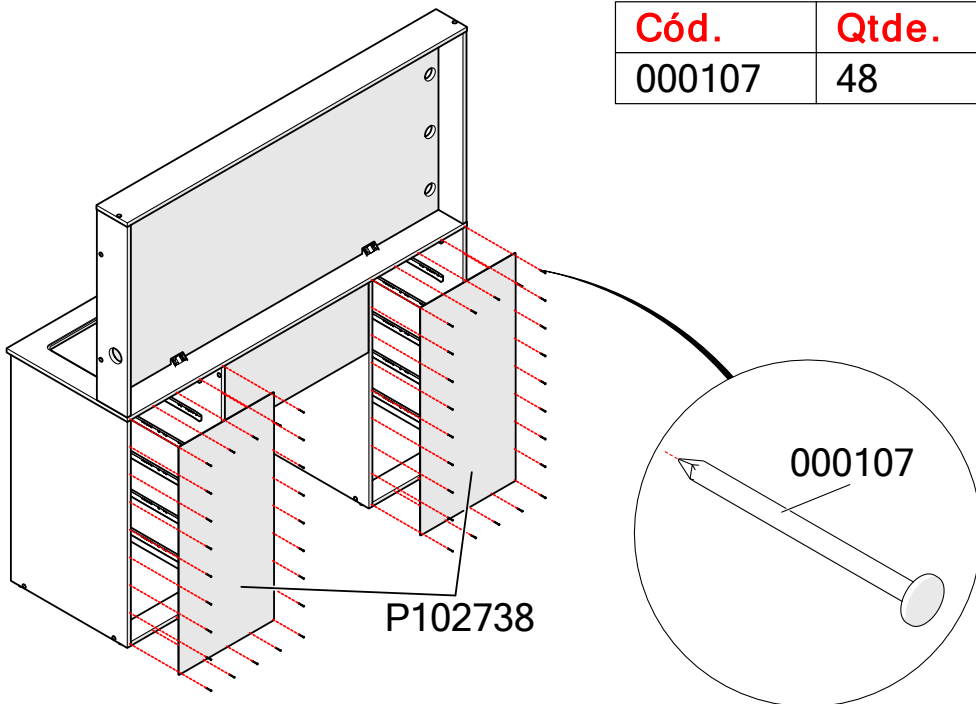

PASO / STEP 26

Fix **Fixation support (055606)** to previous assembly.

Fijar **Soporte de fijación (055606)** a ensamble previo.

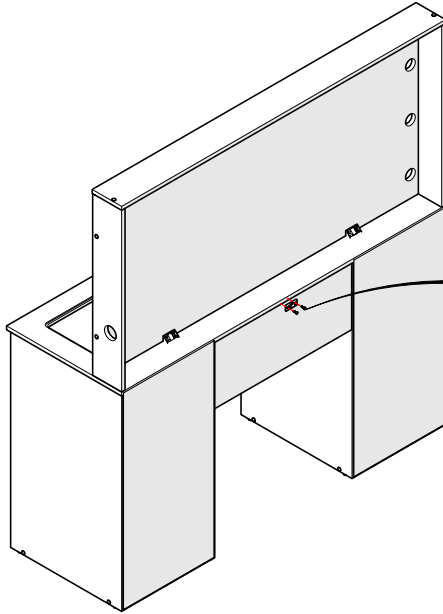

Cód.	Qtde.
001178	2
055606	1

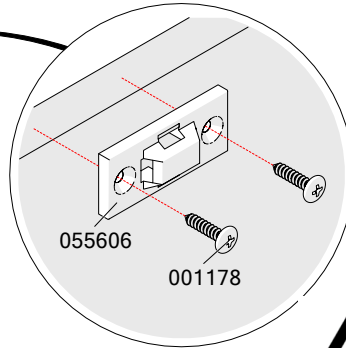

These holes do not come pre-drilled and must be drilled with the screw itself.

Estos agujeros no vienen pretaladrados, y deben taladrarse con con el propio tornillo.



WARNING.
For security measures it is recommended to fix the furniture to the wall to avoid overturning of it, if this happens it can cause serious or fatal injuries.

ATENCIÓN.
Por medidas de seguridad se recomienda fijar el mueble a la pared para evitar volcamiento del mismo, si esto llegase a ocurrir puede causar lesiones graves o fatales.

PASO / STEP 27

Attach the **Fixation support (055606)** to the wall.

Fije las escuadras **Soporte de fijación (055606)** a la pared.

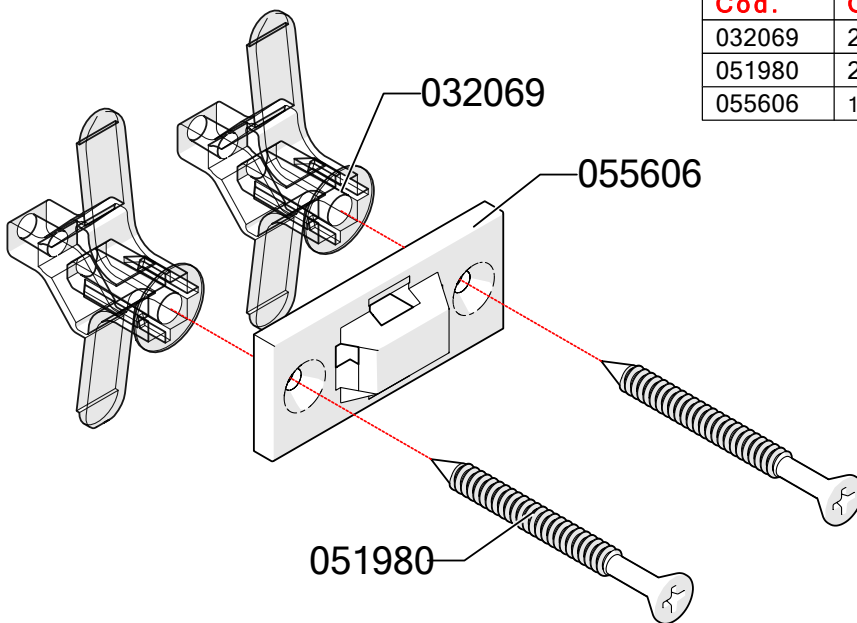

Cód.	Qtde.
032069	2
051980	2
055606	1



Fixing the bracket to the wall.

Fijar el soporte a la pared.

IMPORTANT INFORMATION, PLEASE READ THE INSTRUCTIONS CAREFULLY.

1. Fix the mounting bracket (055606) on the back of the furniture as shown in the figure, using the screws (001178).
2. Locate a post on the wall to attach the mounting bracket (055606), place it approximately 1" below the one that is attached to the furniture. Use wall anchors (032069) and screws (051980).
3. Move the furniture to its final position, taking care to align the wall mounting bracket with the cabinet mounting bracket. Pass the clamp (055607) through each bracket as shown in the picture and tighten enough until it is snug.
4. Make sure all parts are tight.

INFORMACION IMPORTANTE, LEA POR FAVOR CUIDADOSAMENTE LAS INSTRUCCIONES.

1. Monte el soporte de montaje (055606) en la parte posterior del mueble como se muestra en la figura anterior, utilizando los tornillos (001178).
2. Localice un poste en la pared en donde fijará el soporte de montaje (055606), colóquelo aproximadamente 1" por debajo del que fijó en el mueble. Utilice los anclajes de pared (032069) y los tornillos (051980).
3. Mueva el mueble a su posición final, cuidando de alinear el soporte de montaje de la pared con el soporte de montaje del mueble. Pase la abrazadera (055607) a través de cada soporte como se muestra en la imagen y apriete lo suficiente hasta que quede ajustado.

Asegúrese que todas las piezas estén firmemente ajustadas.

Boahaus LLC.
1250-1252

Ave. Franklin Delano Roosevelt,
San Juan, PR 00926.

Please include your sales receipt or other proof of purchase and a specific description of the product defect.

PASO / STEP 28

install the **clamp (055607)**
 instale la **abrazadera (055607)**

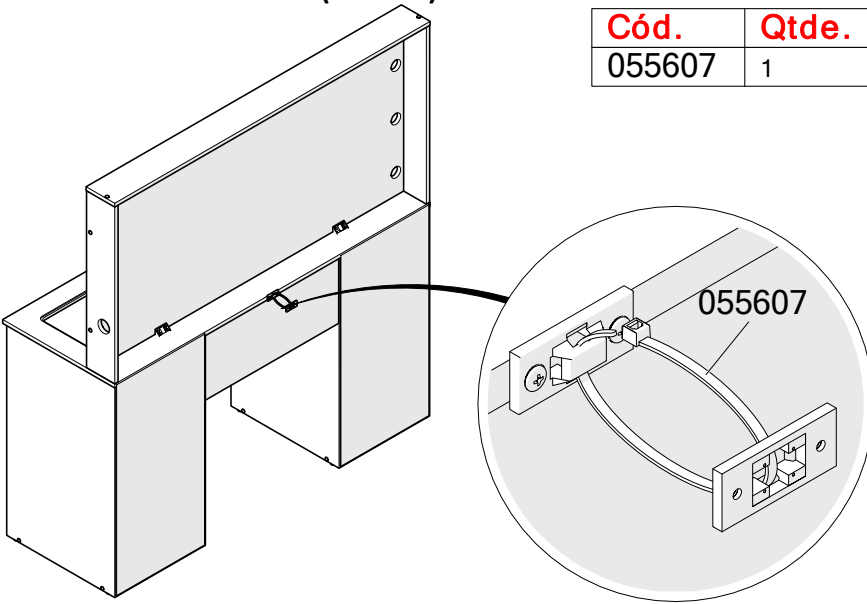

Cód.	Qtde.
055607	1

Step to fix the furniture to the wall.

Paso para fijar los muebles a la pared.

PASO / STEP 29

Attach the side of the **small drawer (P102731/P102732)** to the **rear of the small drawer (P102734)** and to **bottom of drawer (P102737)**.

Coloque el lateral del **cajón pequeño (P102731/P102732)** en la parte posterior del **cajón pequeño (P102734)** a **fondo de cajón (P102737)**.

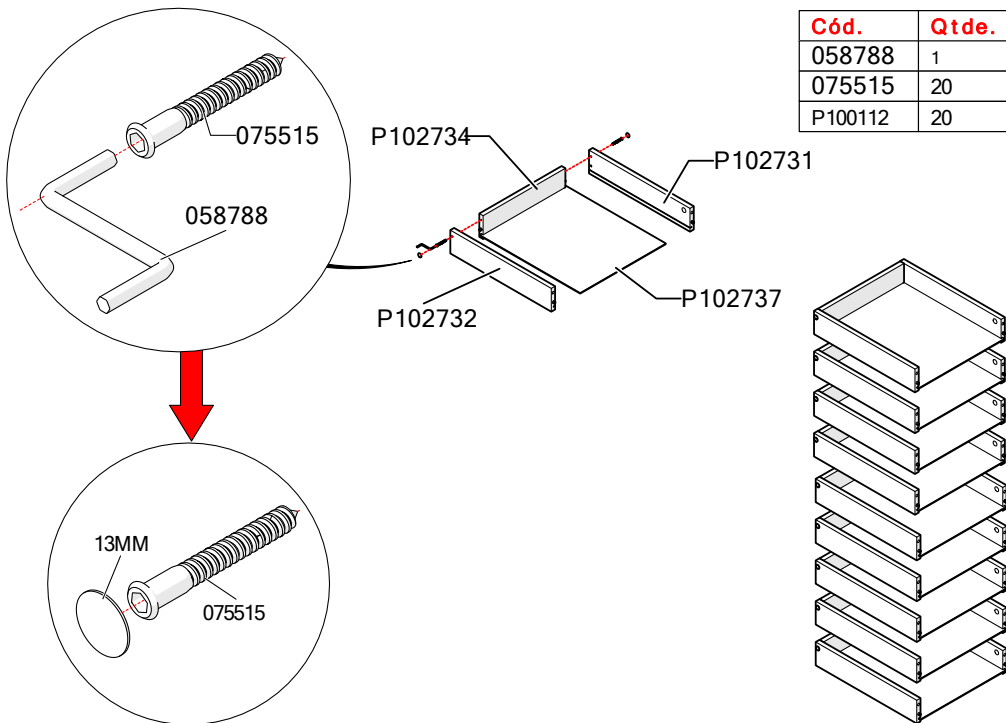

Cód.	Qtde.
058788	1
075515	20
P100112	20

PASO / STEP 30

Attach the side of the **small drawer** (P102731/P102732) to the **rear of the small drawer** (P102734) and to **bottom of drawer** (P102737).

Coloque el lateral del **cajón pequeño** (P102731/P102732) en la parte posterior del **cajón pequeño** (P102734) a **fondo de cajón** (P102737).

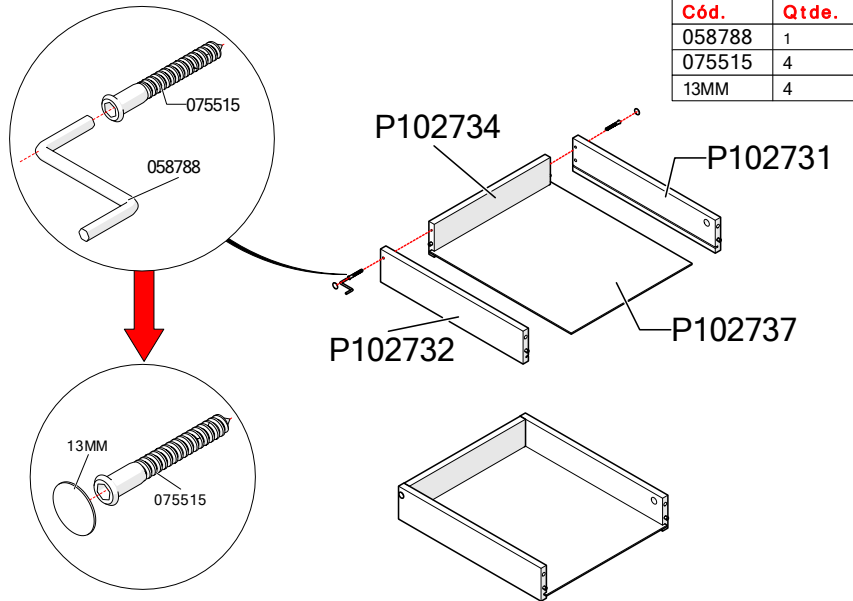

PASO / STEP 31

Fix **side of drawer** (P102731/P102732) and **bottom of drawer** (P102736) to **rear of drawer** (P102733).

Fijar **lateral de cajón central** (P102731/P102732) y **fondo de cajón** (P102736) a **trasero de cajón** (P102733).

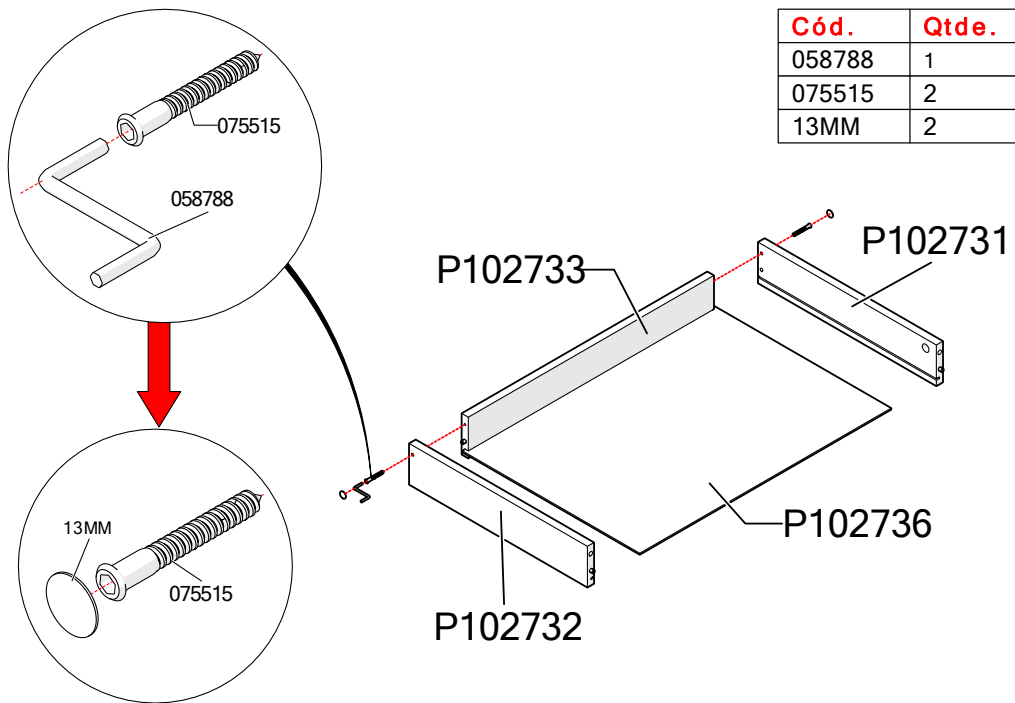

PASO / STEP 32

Attach the **drawer front (P102739)** and previous assembly x10.
 Fije el **frente del cajón (P102739)** al conjunto anterior x10

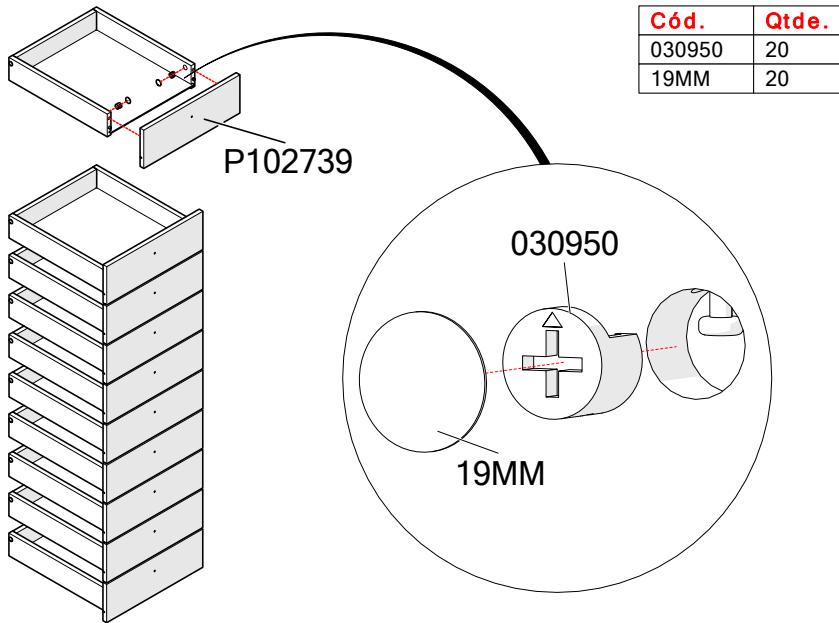

PASO / STEP 33

Attach the **drawer front (P102739)** and previous assembly x2.
 Fije el **frente del cajón (P102739)** al conjunto anterior x2.

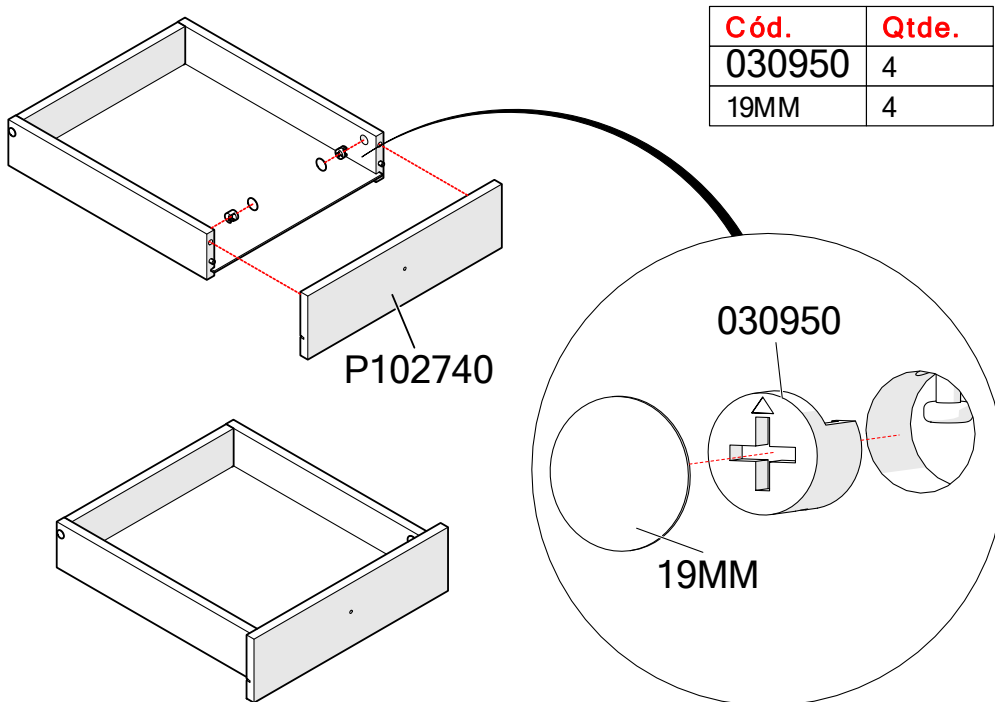

PASO / STEP 34

Attach the **drawer front (P102739)** and previous assembly.
Fije el **frente del cajón (P102739)** al conjunto anterior.

Cód.	Qtde.
030950	2
19MM	2

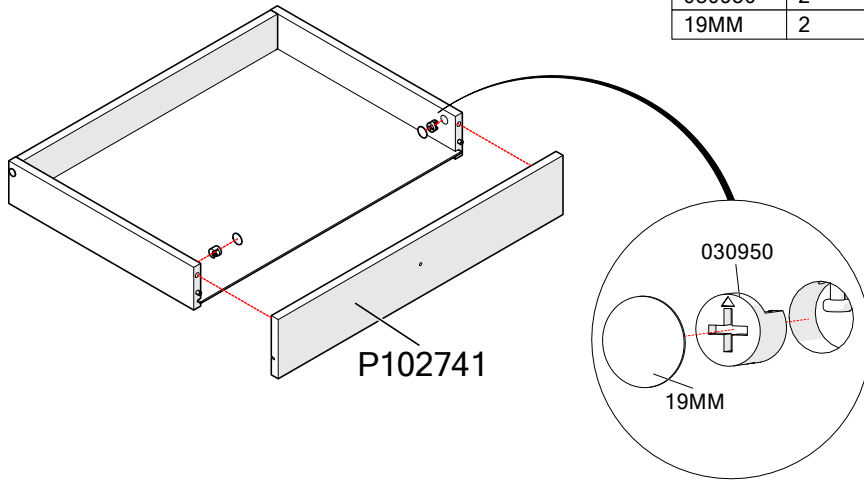

PASO / STEP 35

Fix and **Knob (062448)** to previous assembly x10.

Fijar **tirador (062448)** a ensamble previo x10.

Cód.	Qtde.
062448	10

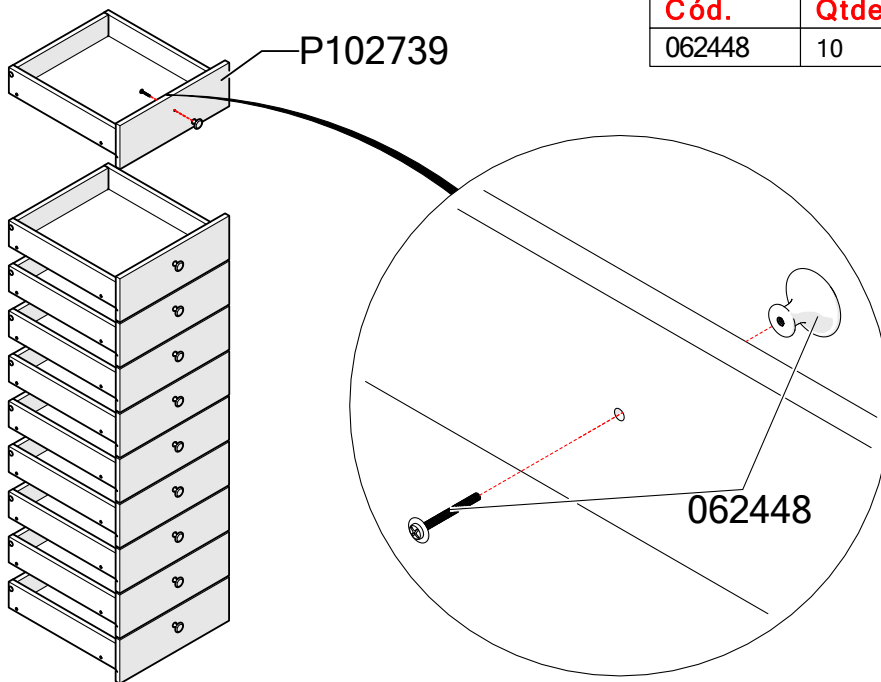

PASO / STEP 36

Fix and **Knob (062448)** to previous assembly x2.

Fijar **tirador (062448)** a ensamble previo x2.

Cód.	Qtde.
062448	2

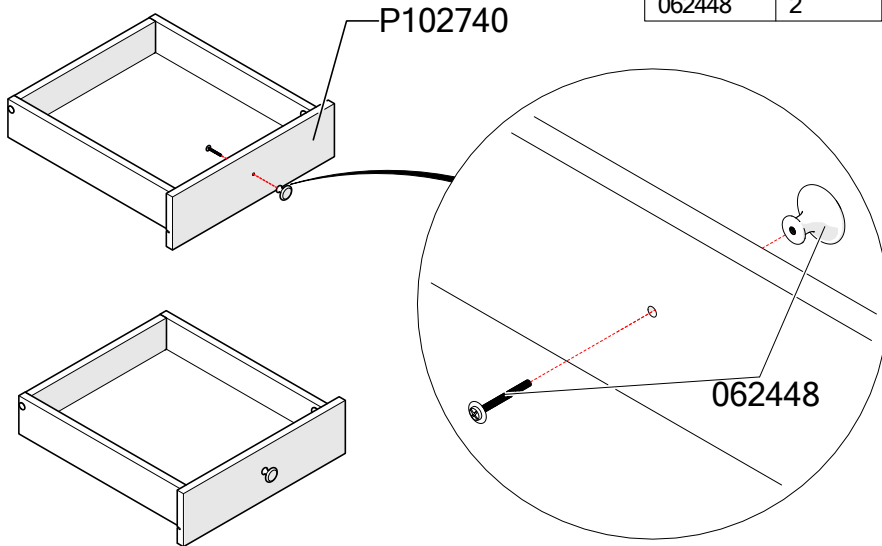

PASO / STEP 37

Fix and **Knob (062448)** to previous assembly.

Fijar **tirador (062448)** a ensamble previo.

Cód.	Qtde.
062448	1

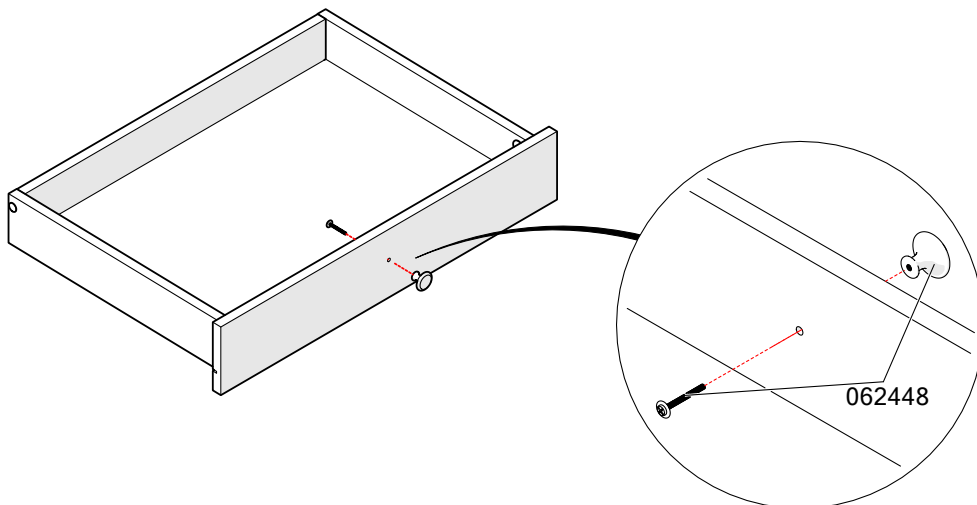

PASO / STEP 38

Fix **drawer support (018458)** and **screw (005256)** to small drawer x10.

Fijar **soporte para cajones (018458)** y a **tornillo (005256)** cajón pequeño x10.

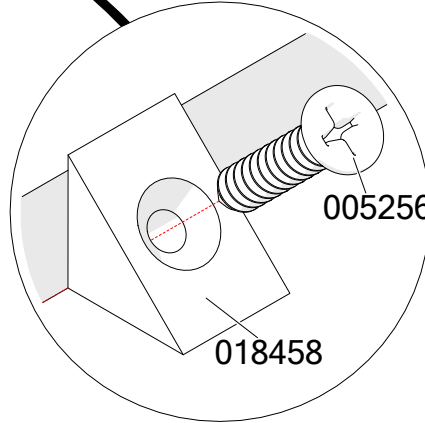
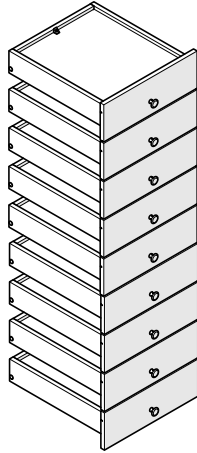
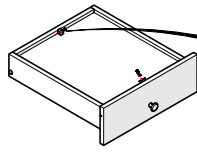

Cód.	Qtde.
005256	20
018458	20

PASO / STEP 39

Fix **drawer support (018458)** and **screw (005256)** to small drawer x2.

Fijar **soporte para cajones (018458)** y a **tornillo (005256)** cajón pequeño x2.

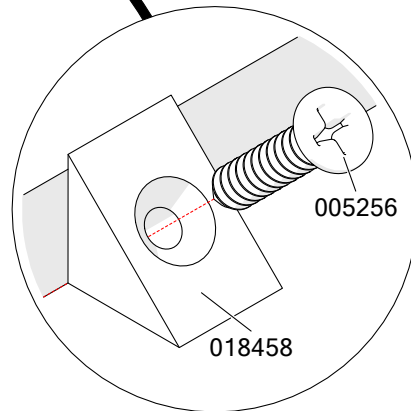
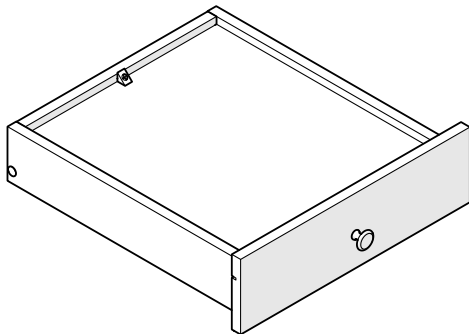
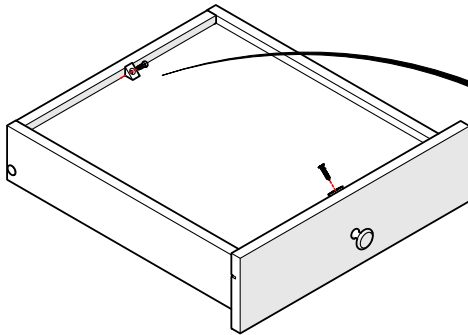

Cód.	Qtde.
005256	4
018458	4

PASO / STEP 40

Fix **drawer support (018458)** and **screw (005256)** to small drawer .

Fijar **soporte para cajones (018458)** y a **tornillo (005256)** cajón pequeño .

Cód.	Qtde.
005256	2
018458	2

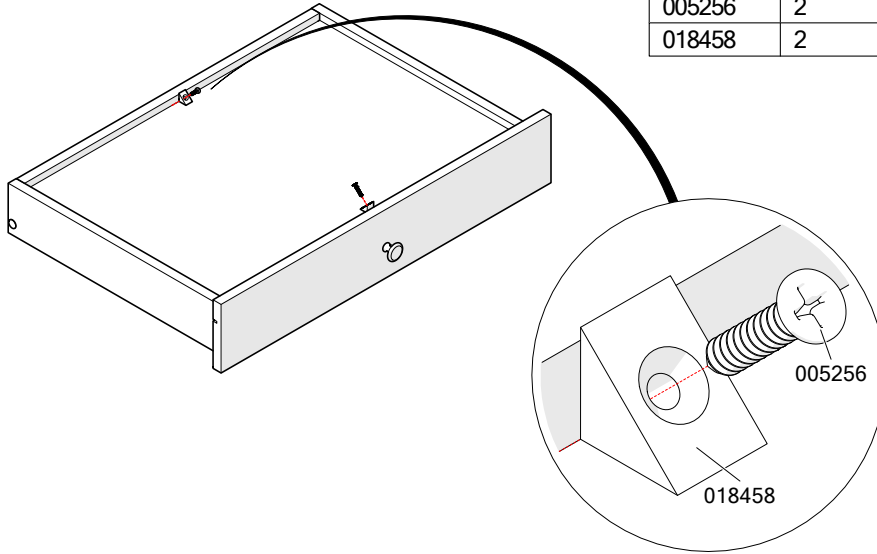

PASO / STEP 41

Fix **left drawer slide (CRM400)** x10 and **drawer slide (CRM400)** x10 to the **drawer x10**.

Fije la **guía izquierda del cajón (CRM400)** x10 y la **guía del cajón (CRM400)** x10 al **cajón x10**.

Cód.	Qtde.
004214	40
CRM400	20

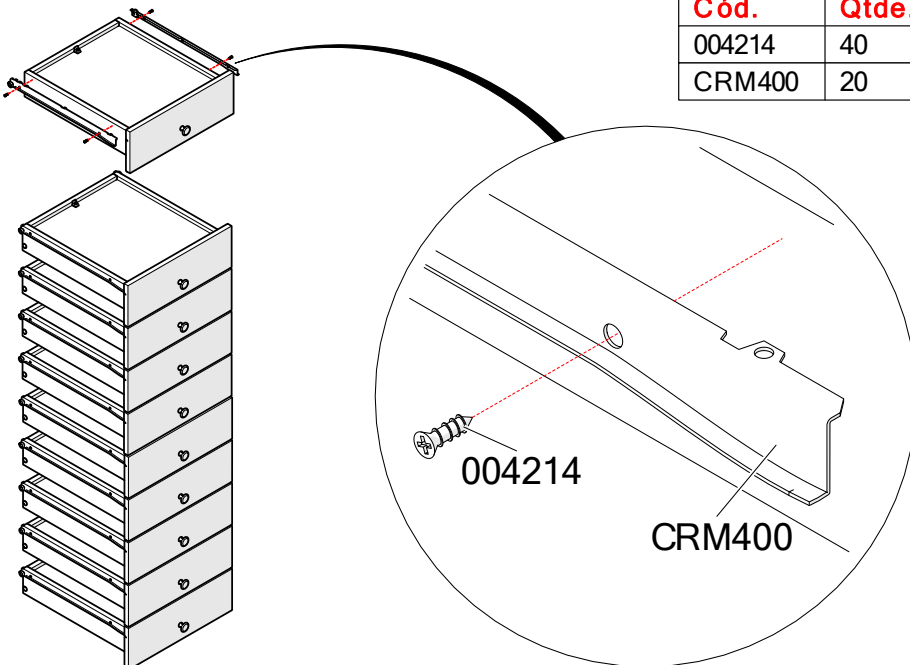

The holes for installing the skid are not prefabricated, they must be drilled as they are installed.
 Los orificios para instalar el patín no están prefabricados, deben taladrarse a medida que se instalan.

PASO / STEP 42

Fix **left drawer slide (CRM400)** x2 and **drawer slide (CRM400)** x2 to the **drawer** x2.

Fije la **guía izquierda del cajón (CRM400)** x2 y la **guía del cajón (CRM400)** x2 al **cajón** x2.

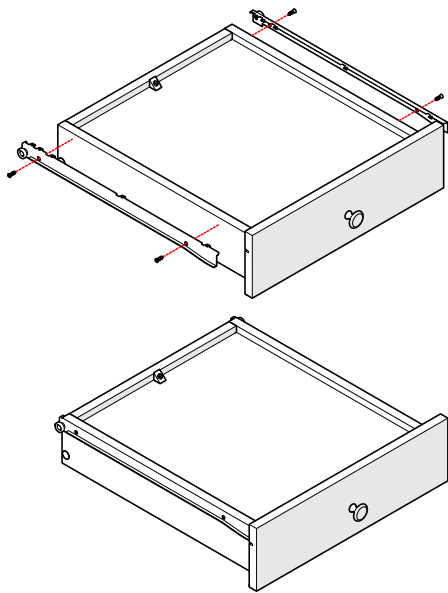

Cód.	Qtde.
004214	8
CRM400	4



The holes for installing the skid are not prefabricated, they must be drilled as they are installed.

Los orificios para instalar el patín no están prefabricados, deben taladrarse a medida que se instalan.

PASO / STEP 43

Fix **left drawer slide (CRM400)** x1 and **drawer slide (CRM400)** x1 to the **drawer** x1.

Fije la **guía izquierda del cajón (CRM400)** x1 y la **guía del cajón (CRM400)** x1 al **cajón** x1.

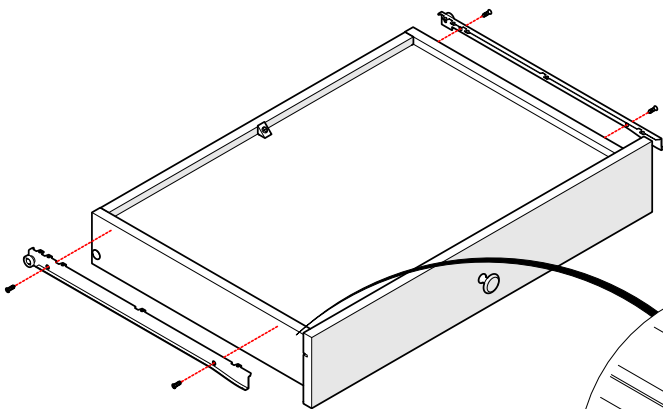

Cód.	Qtde.
004214	4
CRM400	2



The holes for installing the skid are not prefabricated, they must be drilled as they are installed.

Los orificios para instalar el patín no están prefabricados, deben taladrarse a medida que se instalan.

Place drawers.
Colocar cajones.

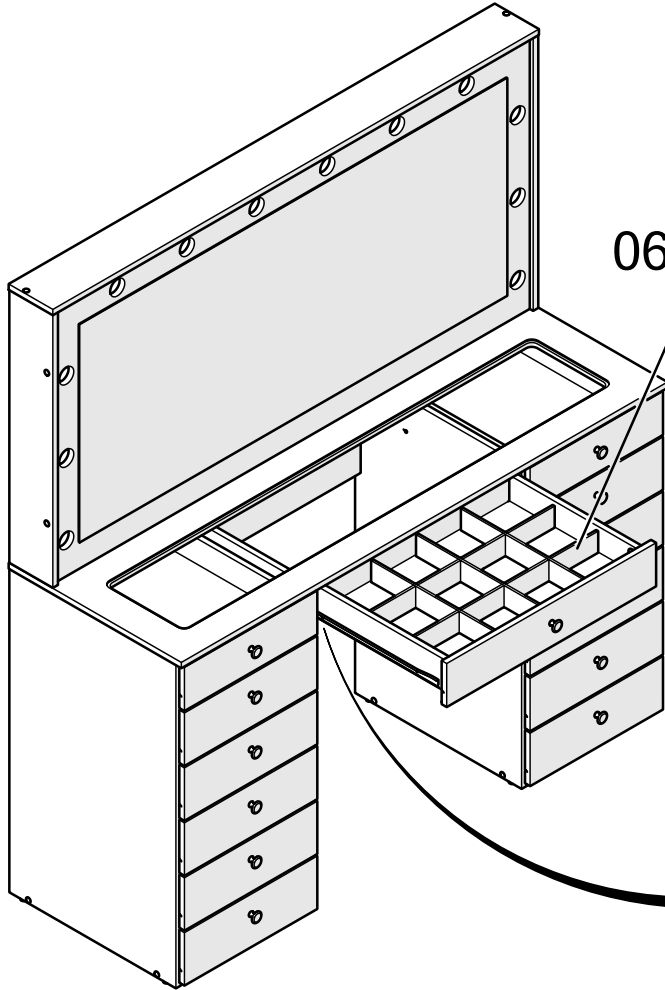

068915

Cód.	Qtde.
068915	1

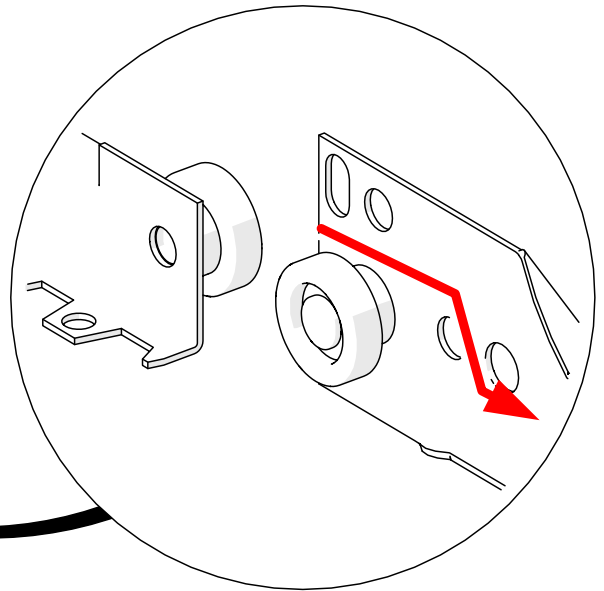

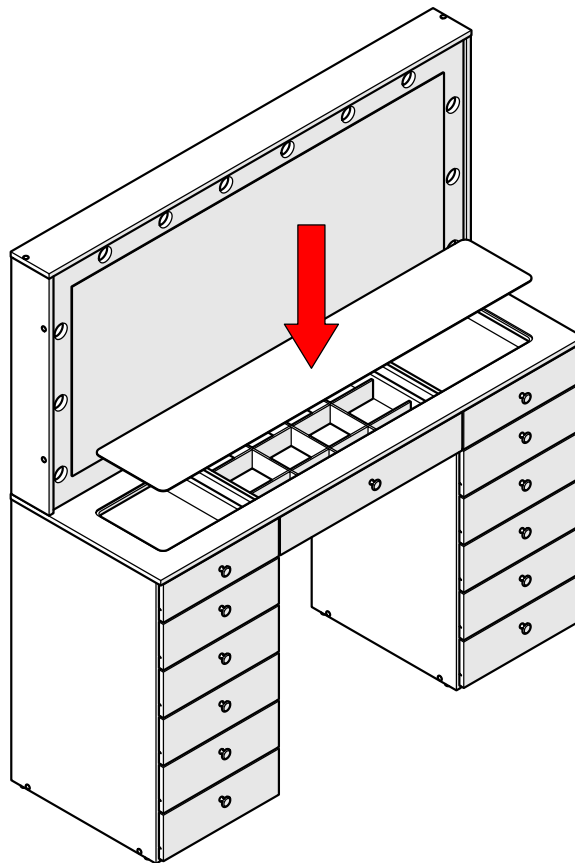

Cód.	Qtde.
068811	1

Congratulations, you have assembled your DRESSING TABLE WITH MIRROR!!!

¡¡¡Felicitaciones, has armado tu Tocador con Espejo!!!

1653 Boahaus DRESSING TABLE WITH MIRROR Warranty 6-Months

Limited Warranty

- a. Boahaus, LLC provides limited warranty coverage to the original purchaser of this product for a period of six months from the date of purchase against defects in materials or workmanship of Boahaus furniture components. As used in this Warranty, “defect” means imperfections in components which substantially impair the utility of the product. This Warranty gives you specific legal rights, and you may also have other rights which vary from state to state.
- b. There is no warranty coverage for defects or conditions that result from the failure to follow product assembly instructions, information or warnings, misuse or abuse, intentional damage, fire, flood, alteration or modification of the product, or use of the product in a manner inconsistent with its intended use, nor any condition resulting from incorrect or inadequate maintenance, cleaning, or care. There is also no warranty coverage for rented products or any products purchased “used” or “as is”, at a distress or going-out-of business sale, or from a liquidator.
- c. As the exclusive remedy under this Warranty, Boahaus will (at its sole option) repair, replace or refund the value of any defective furniture component. Boahaus may require independent confirmation of the claimed defect and proof of purchase. Replacement parts will be warranted for only the remaining period of the original Warranty. BOAHAUS SHALL HAVE NO LIABILITY for ANY INCIDENTAL OR CONSEQUENTIAL DAMAGES OF ANY KIND and all such damages are EXCLUDED FROM THIS WARRANTY, such as loss of use, disassembly, transportation, labor or damage to property on or near the product. Some states do not allow the exclusion or limitation of incidental or consequential damages, so the above limitation or exclusion may not apply to you.
- d. This Warranty applies only to warranted defects that first arise and are transferred to subsequent owners or users of the product, and it shall be immediately void in the event the product is resold, transferred, leased or rented to any third party or person other than the original purchaser.
- e. THERE ARE NO OTHER WARRANTIES APPLICABLE TO THIS PRODUCT. Under the laws of certain states, there may be no implied warranties from Boahaus and all implied warranties, INCLUDING ANY IMPLIED WARRANTY OF MERCHANTABILITY OR FITNESS FOR A PARTICULAR PURPOSE are disclaimed where allowed by law. TO THE EXTENT ANY IMPLIED WARRANTIES ARE APPLICABLE, ANY IMPLIED WARRANTIES, INCLUDING ANY IMPLIED WARRANTY OF MERCHANTABILITY OR FITNESS FOR A PARTICULAR PURPOSE, ARE LIMITED IN DURATION TO THE DURATION OF THIS EXPRESS WARRANTY or the minimum period allowed by law, whichever is shorter. Some states do not allow limitations on how long an implied Warranty lasts, so the above limitation may not apply to you.

For Warranty inquiries, questions about disposition or claims, please visit our website www.boahaus.com. You can also contact Boahaus at +1 (713) 701-5994 or email at administracion@boahaus.com. Boahaus may require Warranty claims to be submitted in writing to:

Boahaus LLC.

1250-1252

Ave. Franklin Delano Roosevelt,

San Juan, PR 00926.

Please include your sales receipt or other proof of purchase and a specific description of the product defect.

Garantía de Tocador con Espejo 1653 Boahaus

1. Boahaus, LLC proporciona cobertura de garantía limitada al comprador original de este producto por un período de 6 meses a partir de la fecha de compra contra defectos en materiales o mano de obra de componentes de muebles de Boahaus. Como se especifica en esta Garantía, "defecto" significa imperfecciones en componentes que perjudican sustancialmente la utilidad del producto. Esta Garantía le otorga derechos legales específicos y también puede tener otros derechos que varían de un estado a otro.
2. No hay cobertura de garantía por defectos o condiciones que resulten del incumplimiento de las instrucciones del producto, o advertencias, uso indebido o abuso, daño intencional, incendio, inundación, alteración o modificación del producto o uso del producto de manera inconsistente con su uso previsto, o cualquier condición resultante de mantenimiento incorrecto o inadecuado, limpieza o cuidado. Tampoco hay cobertura de garantía para productos alquilados o cualquier producto comprado "usado" o "tal cual", en una venta de emergencia o de salida de la empresa, o de un liquidador.
3. Boahaus puede requerir una confirmación independiente del defecto reclamado y un comprobante de compra. Las piezas de repuesto estarán garantizadas durante el período restante de la garantía original. BOAHAUS NO TENDRÁ NINGUNA RESPONSABILIDAD POR CUALQUIER DAÑO INCIDENTAL y todos estos daños ESTÁN EXCLUIDOS DE ESTA GARANTÍA, tales como pérdida de uso, desmontaje, transporte, mano de obra o daños a la propiedad en o cerca del producto. Algunos estados no permiten la exclusión o limitación de daños incidentales o consecuentes, por lo que la limitación o exclusión anterior puede no aplicarse a usted.
4. Esta Garantía se aplica únicamente a los defectos garantizados que surgen y se informan a Boahaus dentro del período de cobertura de la garantía. La garantía no puede ser transferida a los propietarios o usuarios posteriores del producto, y será inmediatamente nula en caso de que el producto sea revendido, transferido, arrendado o alquilado a cualquier tercero o persona que no sea el comprador original.
5. NO HAY OTRAS GARANTÍAS APLICABLES A ESTE PRODUCTO. Bajo las leyes de ciertos estados, no puede haber garantías implícitas de Boahaus y todas las garantías implícitas, INCLUYENDO CUALQUIER GARANTÍA IMPLÍCITA DE COMERCIABILIDAD O ADECUACIÓN PARA UN PROPÓSITO EN PARTICULAR, están exoneradas cuando permitido por la ley. TODAS LAS GARANTÍAS IMPLÍCITAS SON APLICABLES, LAS GARANTÍAS IMPLÍCITAS, INCLUIDAS CUALQUIER GARANTÍA IMPLÍCITA DE COMERCIABILIDAD O ADECUACIÓN PARA UN PROPÓSITO PARTICULAR, ESTÁN LIMITADAS EN DURACIÓN A LA DURACIÓN DE ESTA GARANTÍA EXPRESA o el período mínimo permitido por la ley, cualquiera que sea más corto. Algunos estados no permiten limitaciones sobre la duración de una garantía implícita, por lo que es posible que la limitación anterior no se aplique a usted.
6. Para consultas sobre la garantía, preguntas sobre la disposición o reclamaciones, visite nuestro sitio web www.boahaus.com. También puede ponerse en contacto con Boahaus en +1 (713) 701-5994 o por correo electrónico en administracion@boahaus.com. Boahaus puede requerir que los reclamos de garantía sean presentados por escrito a:

Boahaus LLC.

1250-1252

Ave. Franklin Delano Roosevelt,

San Juan, PR 00926.

Incluya su recibo de compra u otra prueba de compra y una descripción específica del defecto del producto.