

BoatHaus

ASSEMBLY INSTRUCTIONS

ATTENTION!!!

Any inquiry or replacement parts
you need, contact us directly at:

contact@boahaus.com

Scan this QR Code to chat to Customer Support Team.



Or Call Us at +1 (787) 688-1254

BoaHaus

ASSEMBLY INSTRUCTIONS**INSTRUCCIONES DE ARMADO****MODEL #: 4305****FILE CABINET****Archivador****Aprox. product weight 43.14 lbs. / 19,57 Kg. ******Weight may vary +/- 5%.****Lot: See package****Production date: See package****Purchase date: _____**

THIS INFORMATION BOOKLET CONTAINS IMPORTANT SAFETY INFORMATION. PLEASE READ AND KEEP FOR FUTURE REFERENCE.
ESTE FOLLETO CONTIENE INFORMACIÓN DE SEGURIDAD IMPORTANTE. POR FAVOR, LEA Y GUÁRDELO PARA REFERENCIA FUTURA.

Need some Help? Call +1 (787) 688-1254 or email contact@boahaus.com
¿Necesitas ayuda? Llama +1 (787) 688-1254 o envía un email contact@boahaus.com

Need some Help? Call +1 (787) 688-1254 or email contact@boahaus.com
¿Necesitas ayuda? Llama +1 (787) 688-1254 o envía un email contact@boahaus.com

GENERAL SAFETY INFORMATION

1. Please read the Assembly Instructions prior to assembling this product.
2. Remove all the hardware from the box and sort by type.
3. Check to see that all the hardware and parts are present BEFORE assembling.
4. To avoid damage, assemble the product on a sturdy, level and protective surface.
5. Please wait until all steps are completed before fully tightening bolts.
6. Make sure all bolts are tightly fastened before the unit is used.

INFORMACIÓN GENERAL DE SEGURIDAD

1. Lea las instrucciones de armado antes de ensamblar este producto.
2. Extraiga todo el hardware de la caja y ordene por tipo.
3. Verifique que todo el hardware y las piezas están presentes ANTES de ensamblar.
4. Para evitar daños, ensamble el producto sobre una superficie resistente, nivelada y con protección.
5. Espere hasta que todos los pasos se hayan completado antes de apretar completamente los tornillos y accesorios.
6. Asegúrese de que todos los tornillos y accesorios estén bien apretados antes de usar la unidad.

General Dimensions / Dimensiones Generales

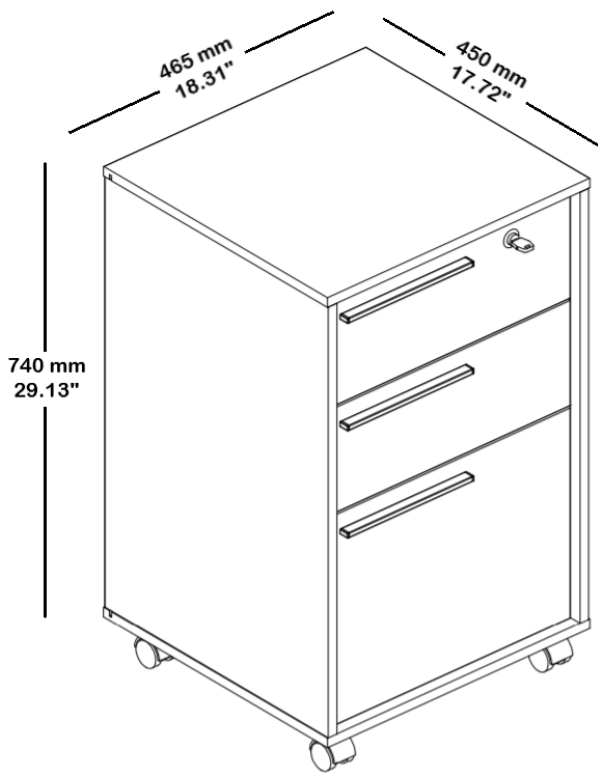

Maximum weight supported / Peso máximo soportado

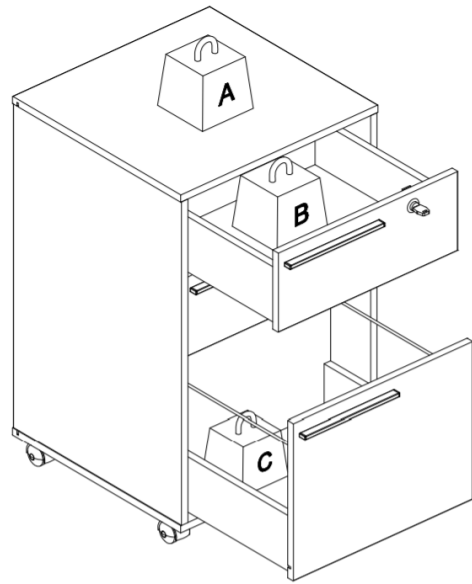

	KG	LB
A	10	22
B	3	6.6
C	5	11

Weight in pounds. / Peso en libras.

Note: weight must be evenly distributed.
Nota: el peso debe estar distribuido uniformemente.

You will need / usted necesitará:

Tools not included / herramientas no incluidas



1 person
1 personas

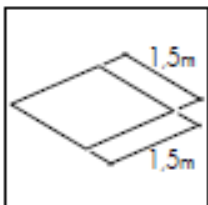

Recommended space for assemble
Espacio recomendado para el armado

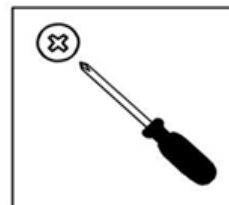







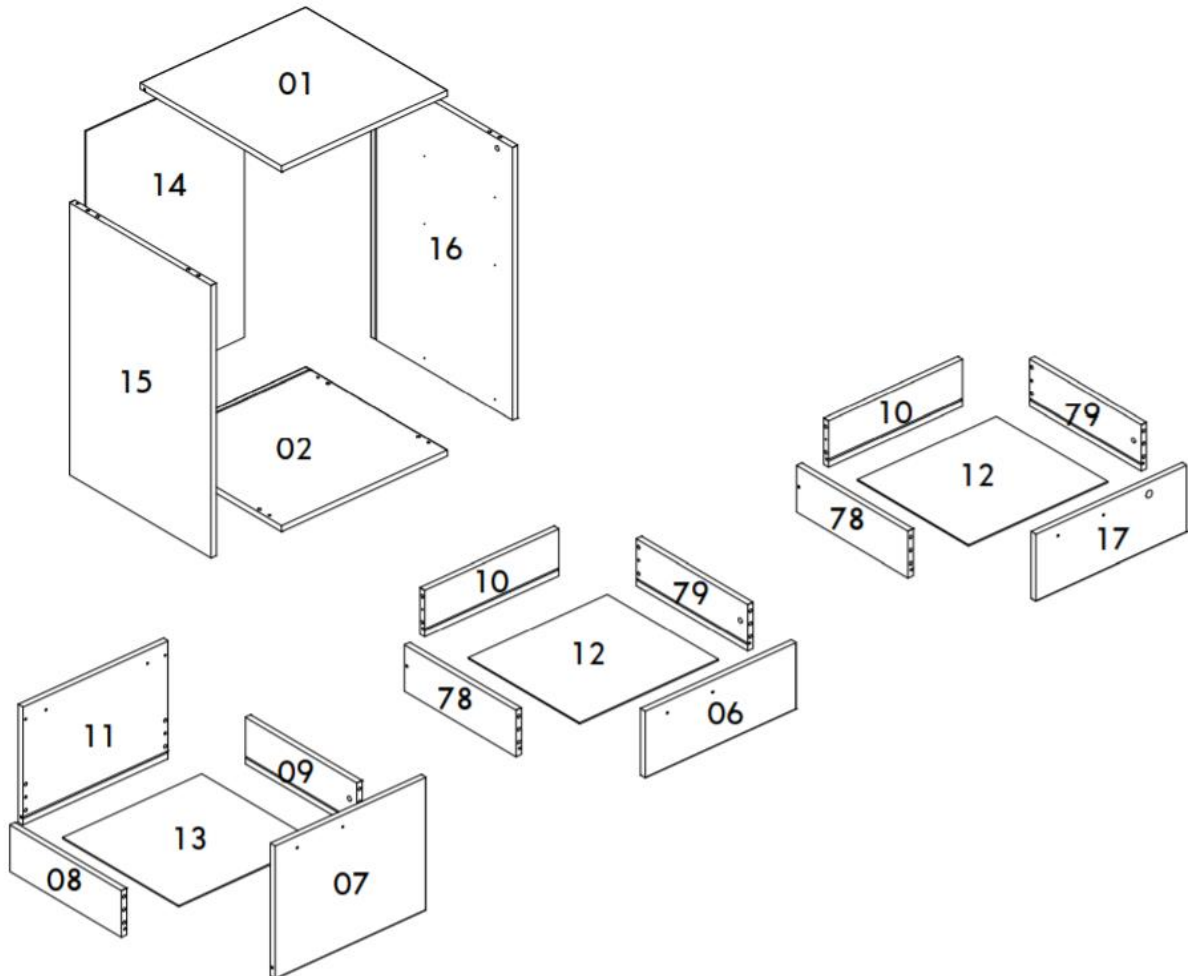





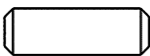
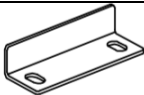

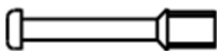
Note: Place a carpet or blanket in the assembly area to avoid damage to the parts during the process.
Nota: Colocar una alfombra o manta en el area de armado para evitar daños en las piezas durante el proceso.



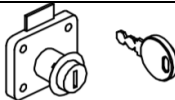

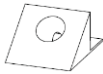
PARTS IDENTIFICATION / IDENTIFICACION DE PARTES

Nº	DESCRIPTION - DESCRIPCIÓN	QTY.
1	Top base / Base superior	1
2	Bottom base / Base inferior	1
6	Front of bottom drawer / Frontal de cajón inferior	1
7	Front of large drawer / Frente de cajón grande	1
8	Left side of large drawer / Lateral izquierdo de cajón grande	1
9	Right side of large drawer / Lateral derecho de cajón grande	1
10	Rear of drawer / Posterior de cajón	2
11	Rear of large drawer / Posterior de cajón grande	1
12	Bottom of drawer / Fondo de cajón	2
13	Bottom of large drawer / Fondo de cajón grande	1
14	Backboard / Fondo	1
15	Left side / Lateral izquierdo	1
16	Right side / Lateral derecho	1
17	Front of top drawer / Frontal de cajón superior	1
78	Left side of drawer / Lateral izquierdo de cajón	2
79	Right side of drawer / Lateral derecho de cajón	2

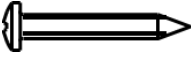

IDENTIFICATION OF ACCESSORIES / IDENTIFICACION DE ACCESORIOS

NUMBER		DESCRIPTION	QTY.
A1		Glue / Pegamento	1
A8		Flat head screw / Tornillo cabeza plana (3,5 x 20 mm)	4
E		Wooden dowel / Pin (8 x 30 mm)	32
G2		Door stop / Tope de puerta	1
H6A		Caster / Ruedas	4
H9		Plastic hole plugs / tapones plásticos	4
J		Simple minifix screw / Tornillo minifix simple	10
L		Drum lock / Tambor minifix	10
M		Adhesive bore patch / Tapón adhesivo	6
N13		Folder support / Soporte de carpeta	2
N14		Lock / Cerradura	1
O		Flat head screw / Tornillo cabeza plana (4,5 x 45 mm)	10
O1		Triangle support / Soporte triangular	4
O2		Handle / Tirador	3
O9		Flanged head screw / Tornillo cabeza flangeada (3,5 x 16 mm)	4
P5		Flat head screw / Tornillo cabeza plana (3.5 x 14 mm)	24

S		Pan head screw / Tornillo cabeza redondeada (3,5 x 14 mm)	20
T		Flanged head screw / Tornillo cabeza flangeada (3,5 x 25 mm)	6
VA		Metallic left slide 350mm / corredera lateral izquierda 350mm	3
VB		Metallic right slide 350 mm / Corredera lateral derecha 350mm	3
VC		Left drawer slide 350mm / Corredera cajón izquierda 350mm	3
VD		Right drawer slide 350 mm/ Corredera cajón derecha 350 mm	3

PRE-ASSEMBLY / PRE- ARMADO

1. Fix **simple minifix screw** (J) and **door stop** (G2) to **top base** (1).
Fijar **tornillo minifix simple** (J) y **tope de puerta** (G2) a **base superior** (1).

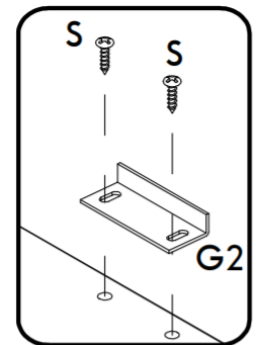
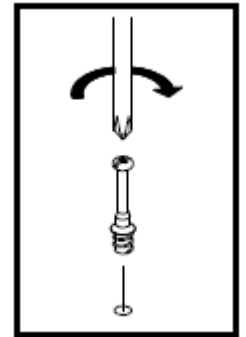
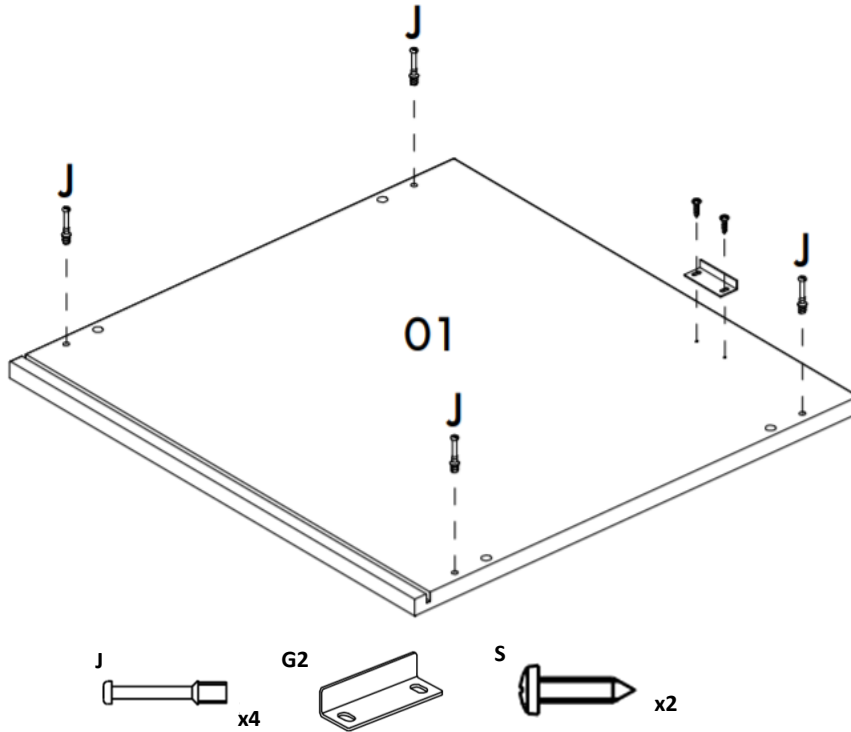

2. Fix **wooden dowel** (E) and **metallic right slide** (VB) to **right side** (16).
Fijar **pin** (E) y **corredera lateral derecha** (VB) a **lateral derecho** (16).

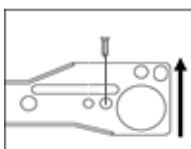
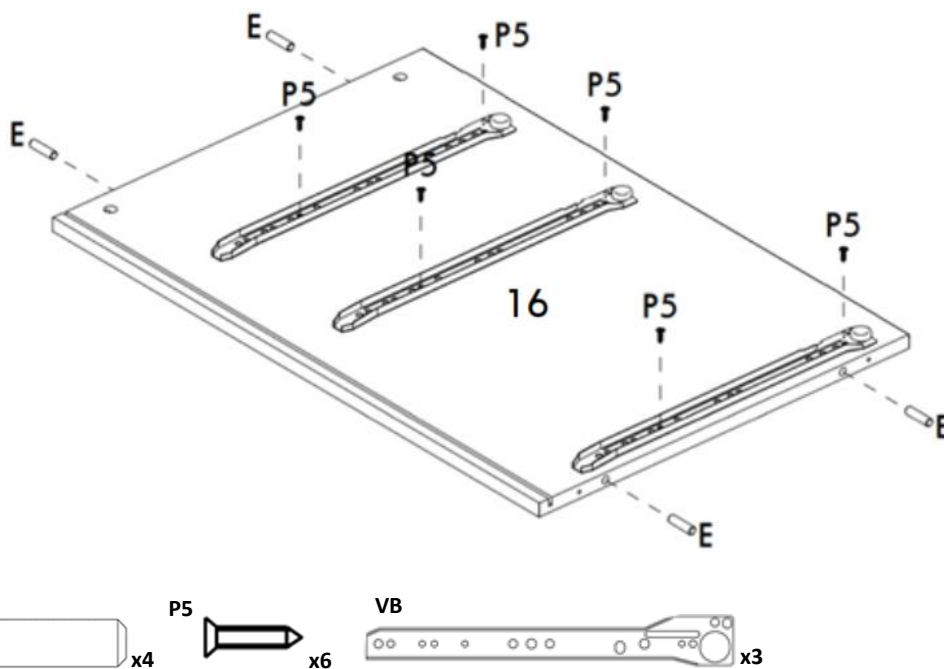

Note: the two upper holes have to be facing up.
Nota: los dos agujeros superiores deben estar hacia arriba.

3. Fix **wooden dowel** (E) and **metallic left slide** (VA) to **left side** (15).
 Fijar **pin** (E) y **corredera lateral izquierda** (VA) a **lateral izquierdo** (15).

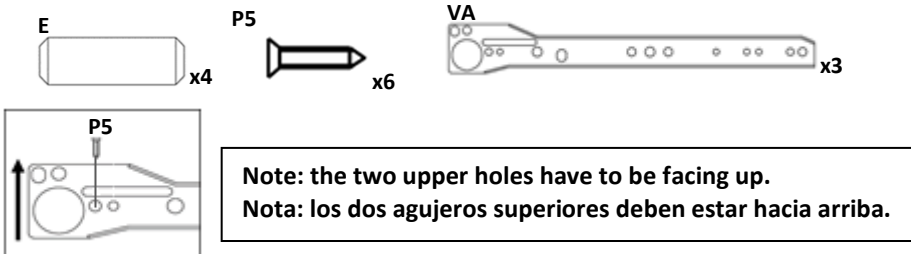
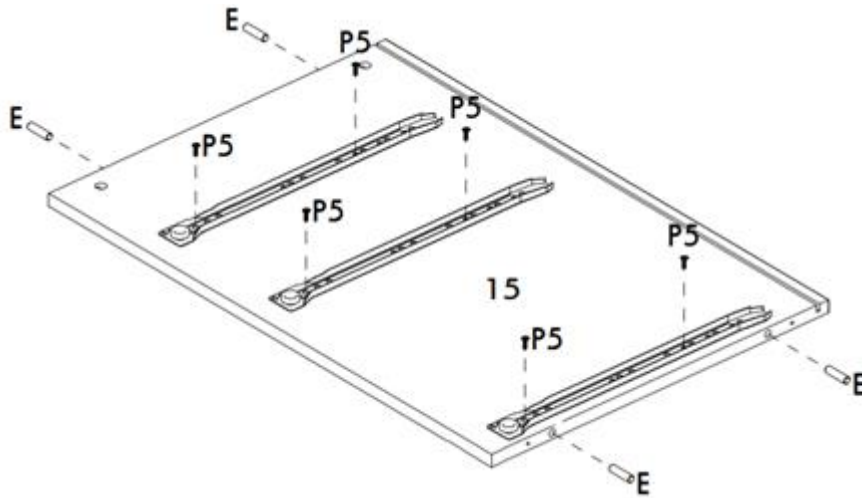

4. Fix **simple minifix screw** (J) to **front of bottom drawer** (6) and **front of large drawer** (7).
 Fijar **tornillo minifix simple** (J) a **frontal de cajón inferior** (6) y **frontal de cajón grande** (7).

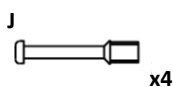
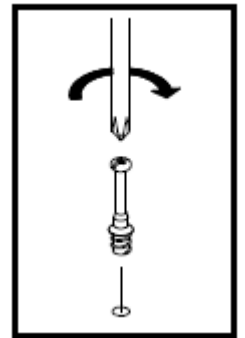
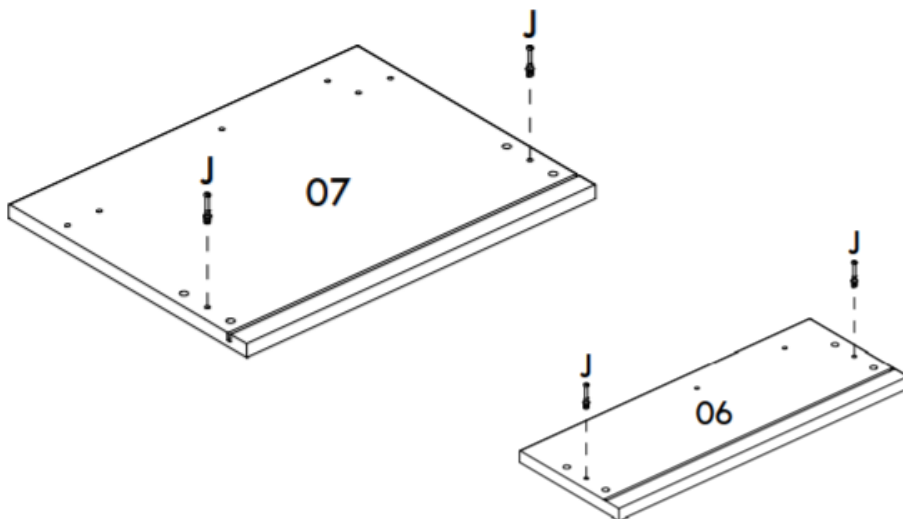

5. Fix **simple minifix screw (J)** and **lock (N14)** to **front of top drawer (17)**.
 Fijar **tornillo minifix simple (J)** y **cerradura (N14)** a **frontal de cajón superior (17)**.

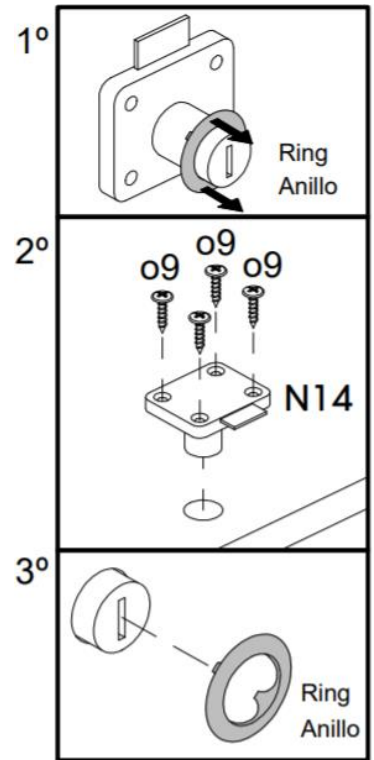
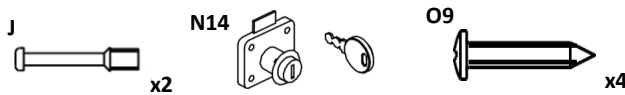
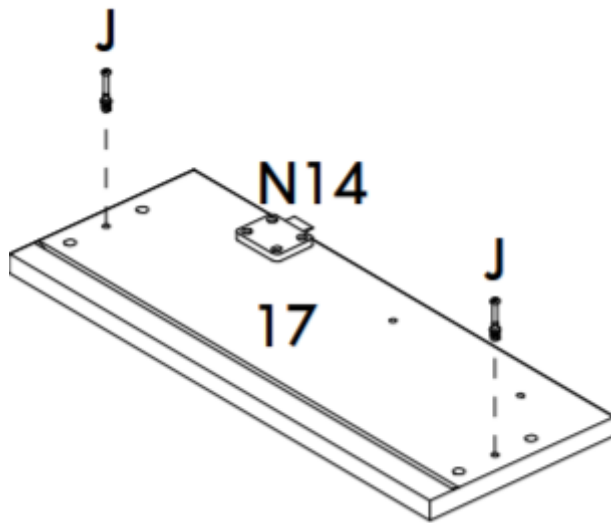

6. Fix **wooden dowel (E)** to **left side of large drawer (8)** and **right side of large drawer (9)**.
 Fijar **pin (E)** a **lateral de izquierdo de cajón grande (8)** y **lateral derecho de cajón grande (9)**.

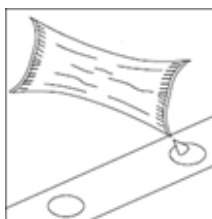
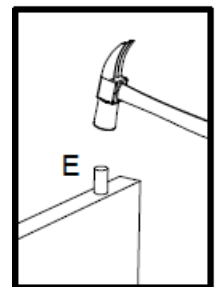
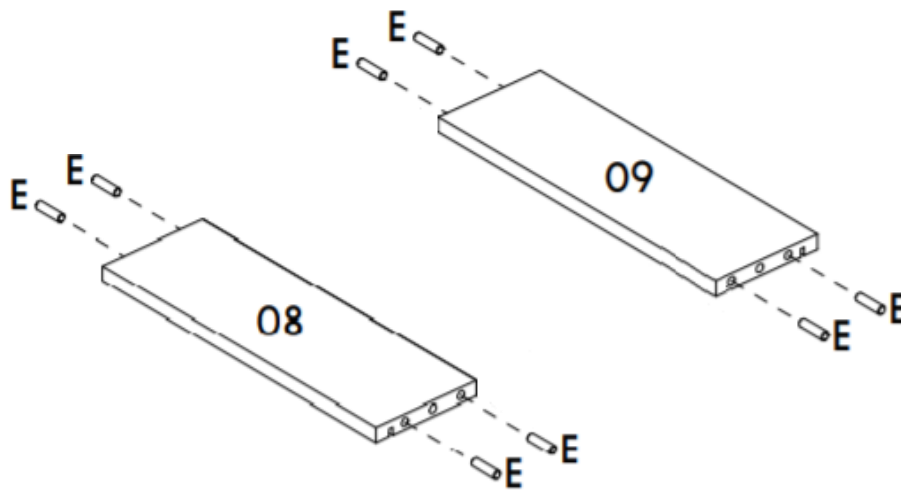

Note: add glue (A1) in the holes before placing the wooden dowel
Nota: agregue el pegamento (A1) en los agujeros antes de colocar el pin.

7. Fix **wooden dowel** (E) to **left side of drawer** (78) x2 and **right side of drawer** (79) x2.
 Fijar **pin** (E) a **lateral izquierdo de cajón** (78) x2 y **lateral derecho de cajón** (79) x2.

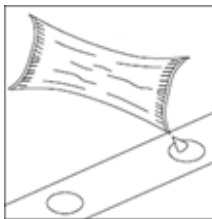
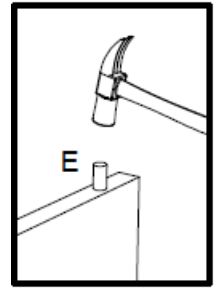
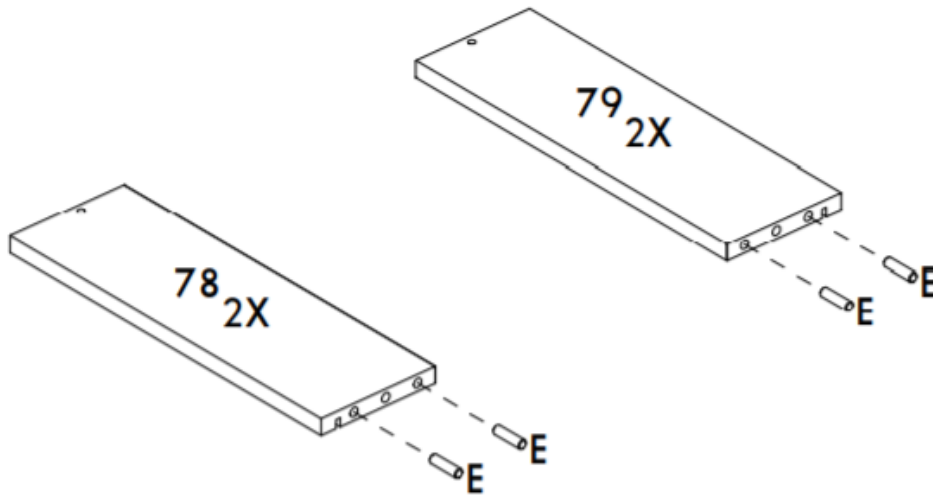

Note: add glue (A1) in the holes before placing the wooden dowel
Nota: agregue el pegamento (A1) en los agujeros antes de colocar el pin.

8. Fix **wooden dowel** (E) to **rear of drawer** (10) x2.
 Fijar **pin** (E) a **posterior de cajón** (10) x2.

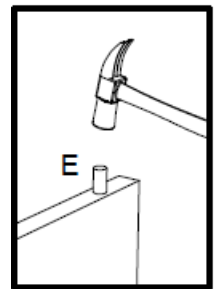
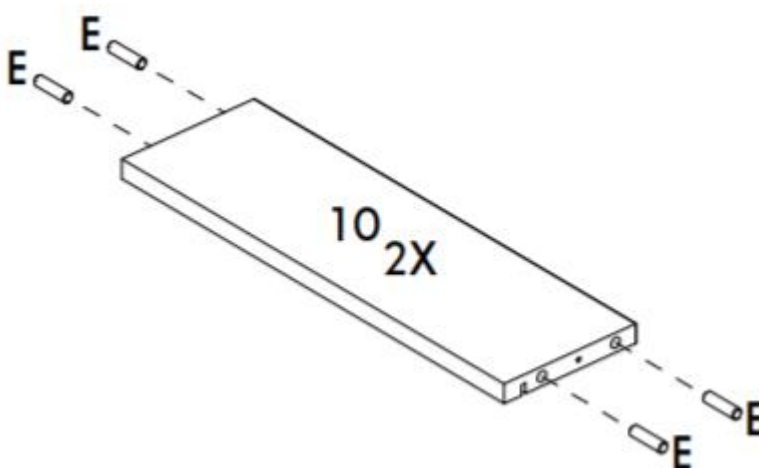

ASSEMBLY / ARMADO

9. Fix **left side** (15) and **right side** (16) to **bottom base** (2).
Fijar **lateral izquierdo** (15) y **lateral derecho** (16) a **base inferior** (2).

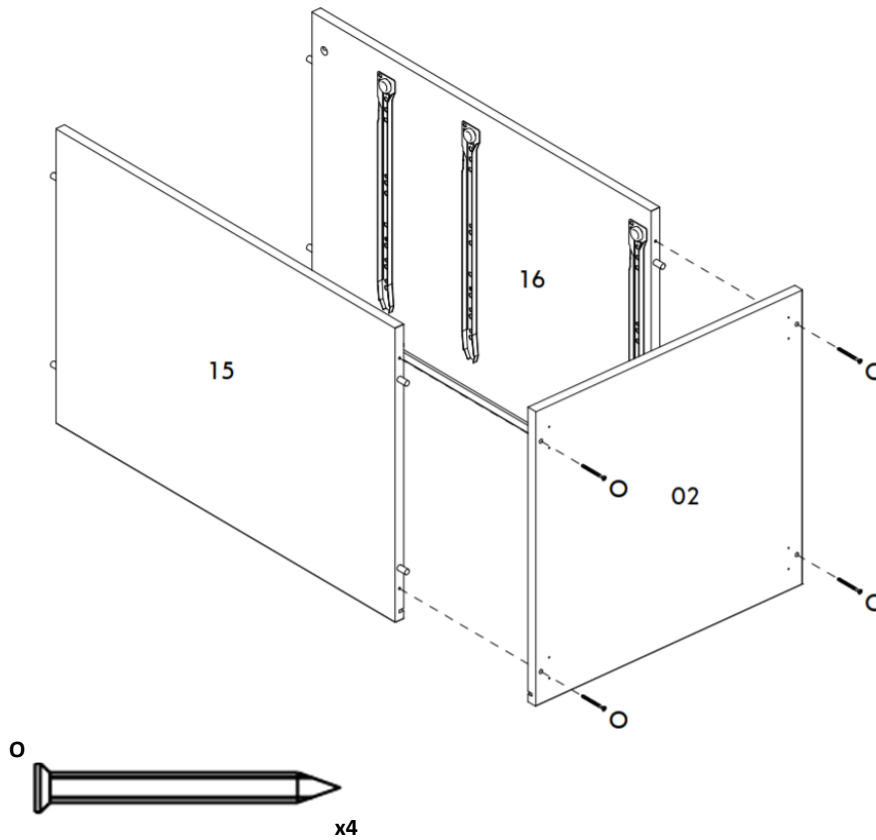

10. Fix **backboard** (14) to previous assembly.
Fijar **fondo** (14) a ensamble previo.

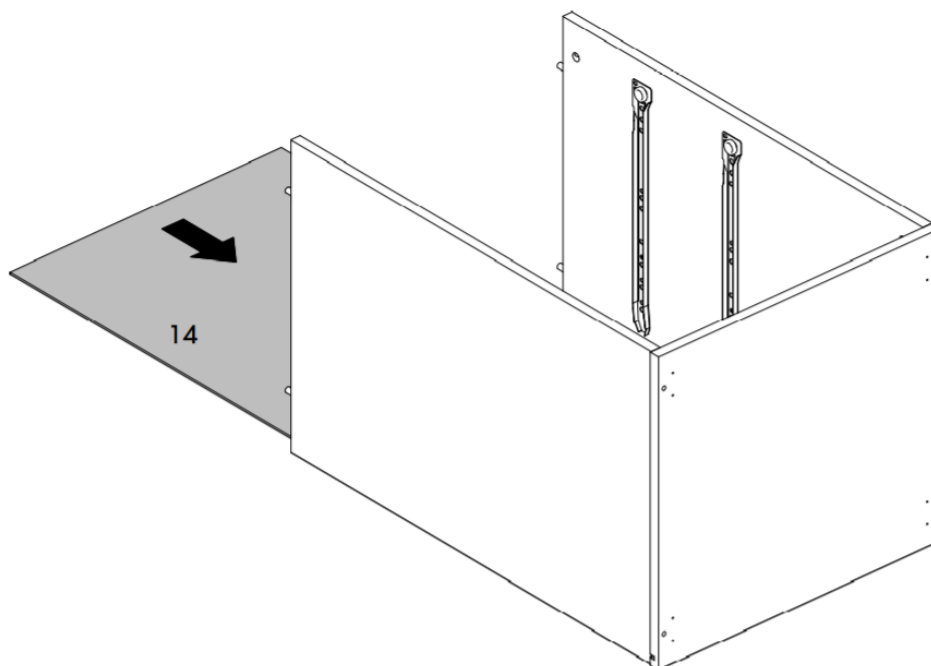

11. Fix **top base** (1) to previous assembly.
 Fijar **base superior** (1) a ensamble previo.

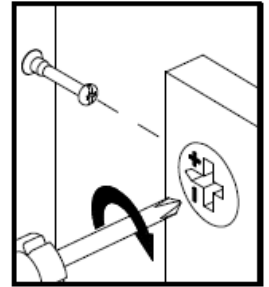
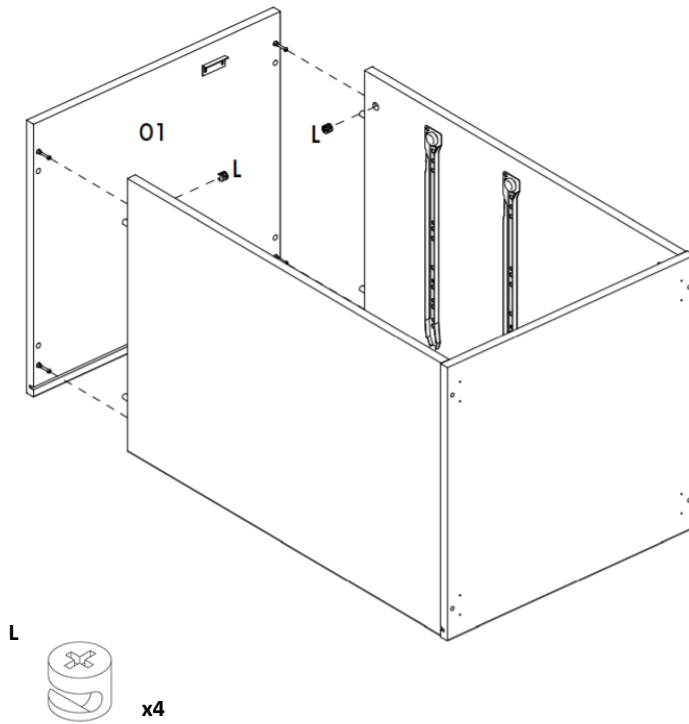

12. Fix **caster** (H6A) to previous assembly.
 Fijar **ruedas** (H6A) a ensamble previo.

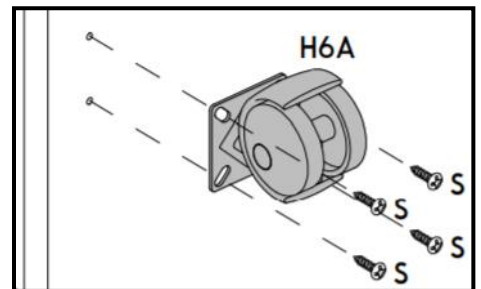
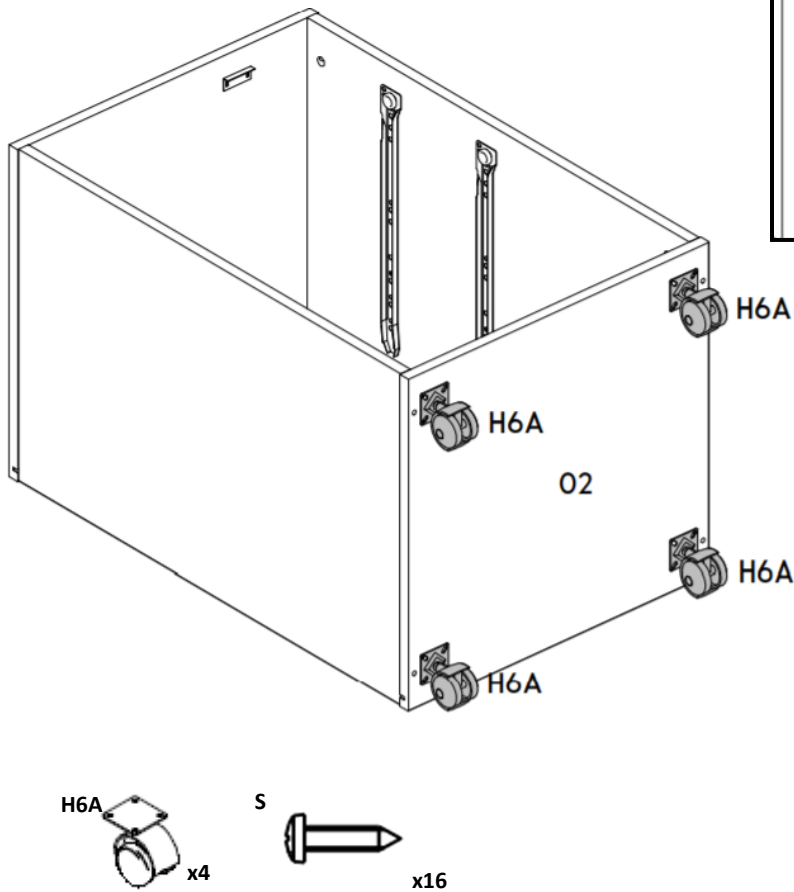

13. Fix **triangle support** (O1) to previous assembly.
 Fijar **soporte triangular** (O1) a ensamble previo.

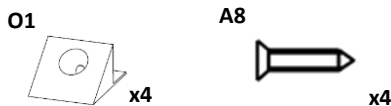
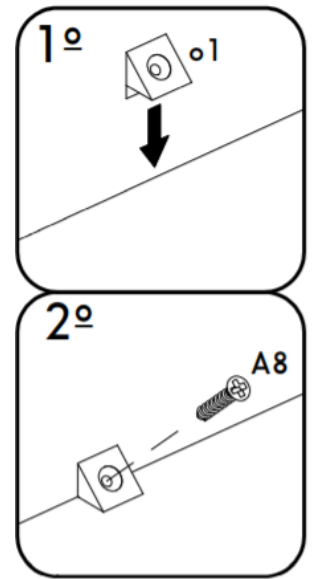
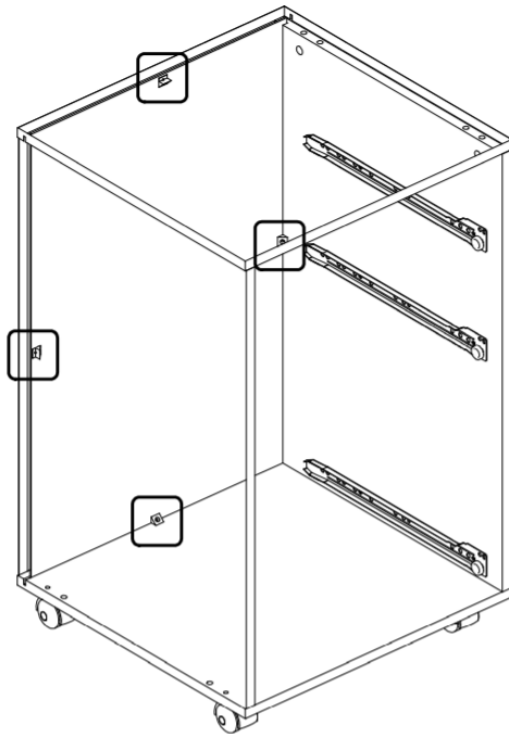

14. Fix **left side of drawer** (78) x2, **right side of drawer** (79) x2 and **bottom of drawer** (12) x2 to rear of **drawer** (10) x2.
 Fijar **lateral izquierdo de cajón** (78) x2, **lateral derecho de cajón** (79) x2 y **fondo de cajón** (12) x2 a **posterior de cajón** (10) x2.

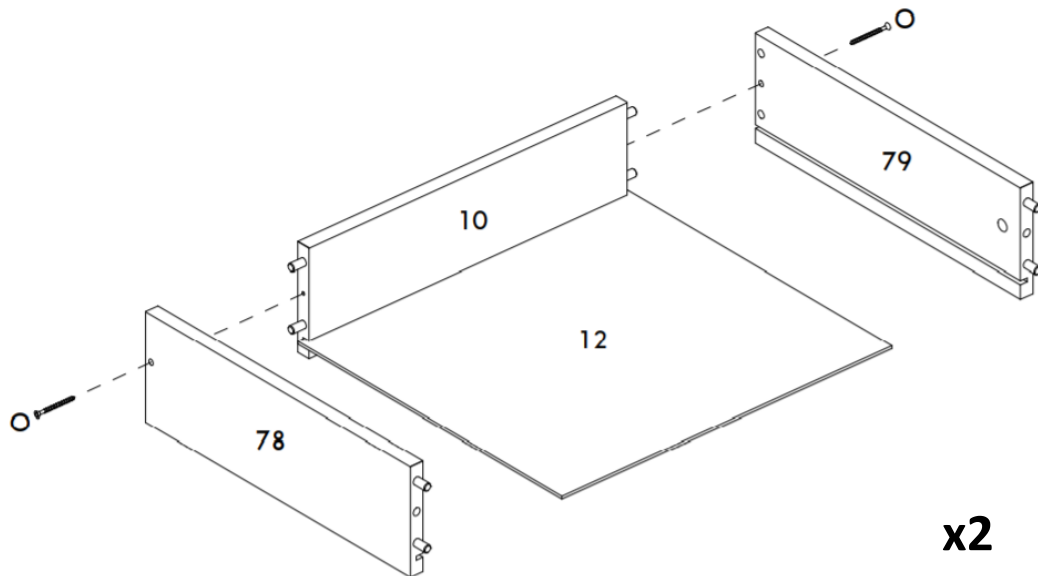

15. Fix **front of top drawer** (17) to previous assembly
 Fijar **frontal de cajón superior** (17) a ensamble previo.

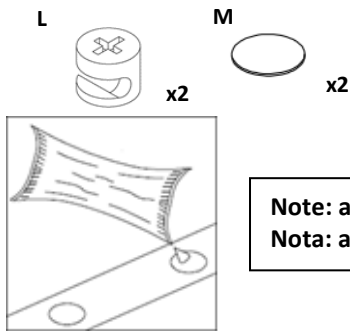
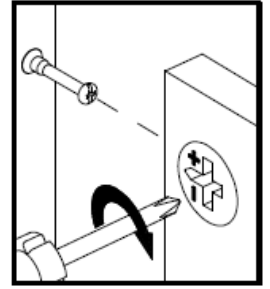
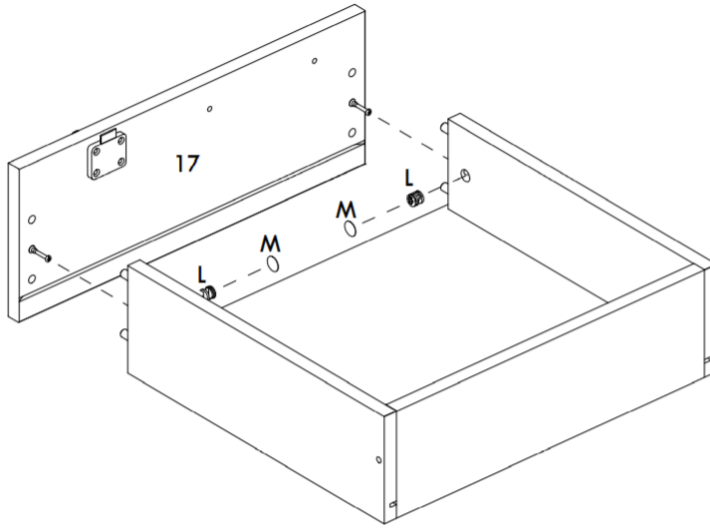

Note: add glue (A1) in the holes before placing the wooden dowel
Nota: agregue el pegamento (A1) en los agujeros antes de colocar el pin.

16. Fix **handle** (O2) to previous assembly.
 Fijar **manilla** (O2) a ensamble previo.

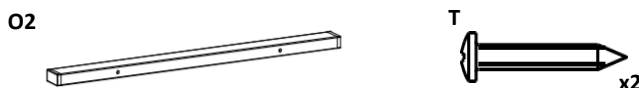
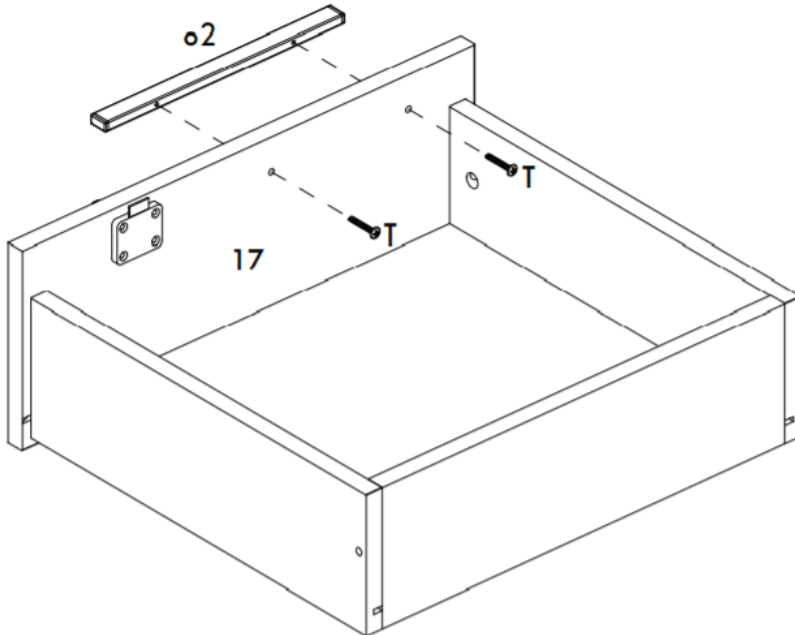

17. Fix **front of bottom drawer** (6) to previous assembly (step 14).
 Fijar **frontal de cajón inferior** (6) a ensamble previo (paso 14).

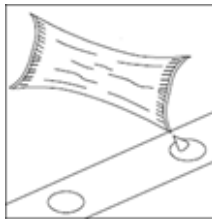
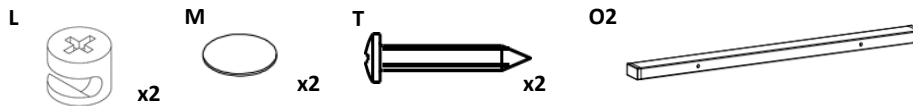
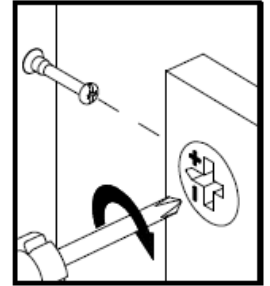
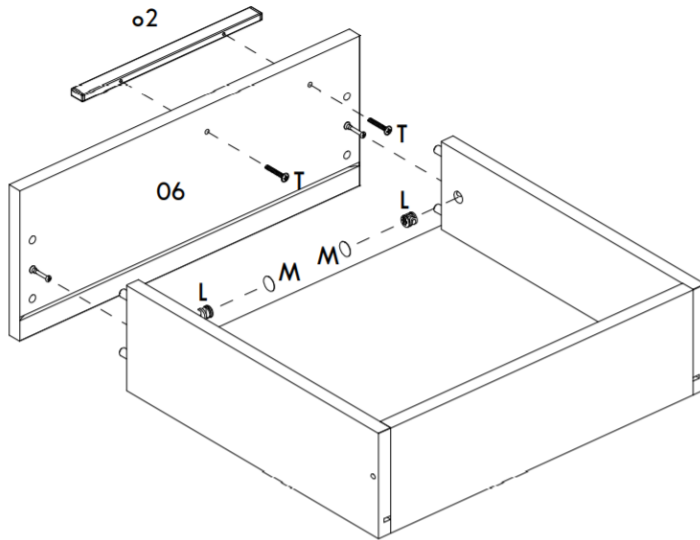

Note: add glue (A1) in the holes before placing the wooden dowel
Nota: agregue el pegamento (A1) en los agujeros antes de colocar el pin.

18. Fix **left drawer slide** (VC) and **right drawer slide** (VD) to previous assemblies (step 16 and 17).
 Fijar **corredera de cajón izquierdo** (VC) y **corredera de cajón derecho** (VD) a ensambles previos (paso 16 y 17).

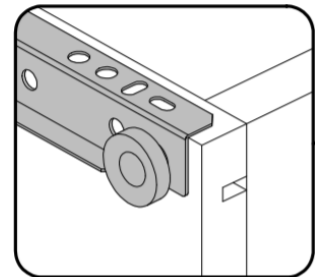
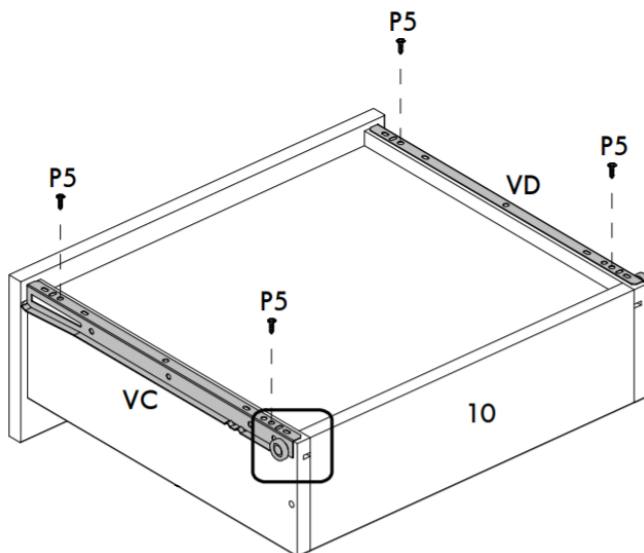

x2

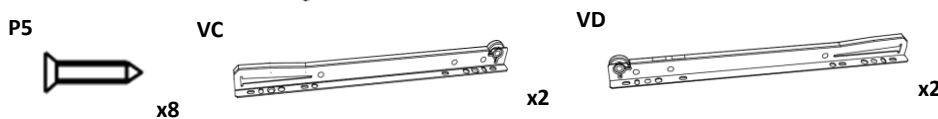

Note: the missing holes must be made with the screwdriver and the corresponding screw.
Nota: los agujeros faltantes deben hacerse con el destornillador y el tornillo correspondiente.

19. Fix **left side of large drawer** (8) and **right side of large drawer** (9) to **rear of large drawer** (11).
 Fijar **lateral izquierdo de cajón grande** (8) y **lateral derecho de cajón grande** (9) a **posterior de cajón grande** (11).

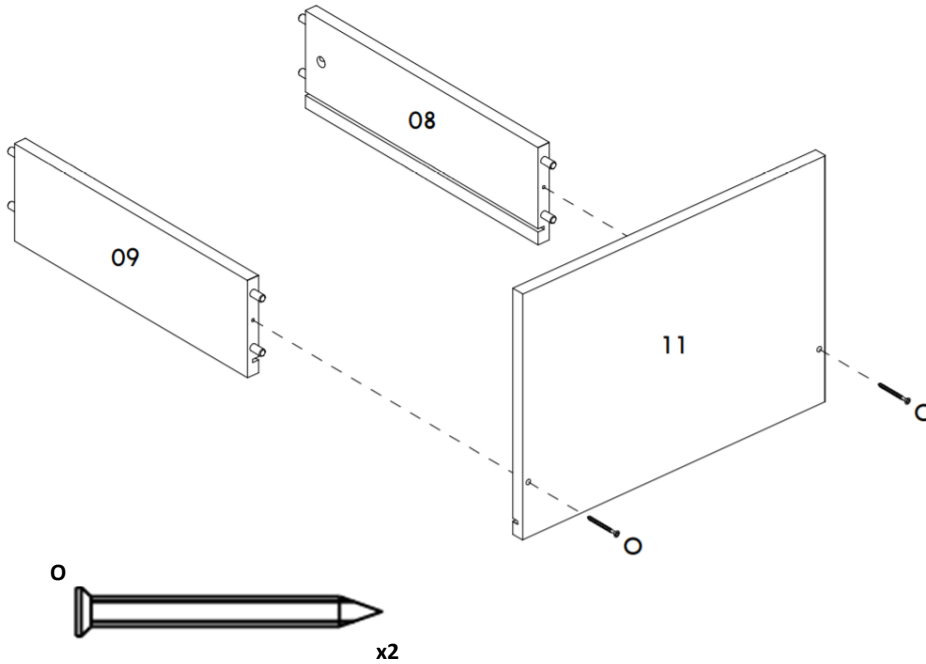

20. Fix **bottom of large drawer** (13), **folder support** (N13) and **plastic hole plugs** (H9) to previous assembly.
 Fijar **fondo de cajón grande** (13), **soporte de carpeta** (N13) y **tapones plásticos** (H9) a ensamble previo.

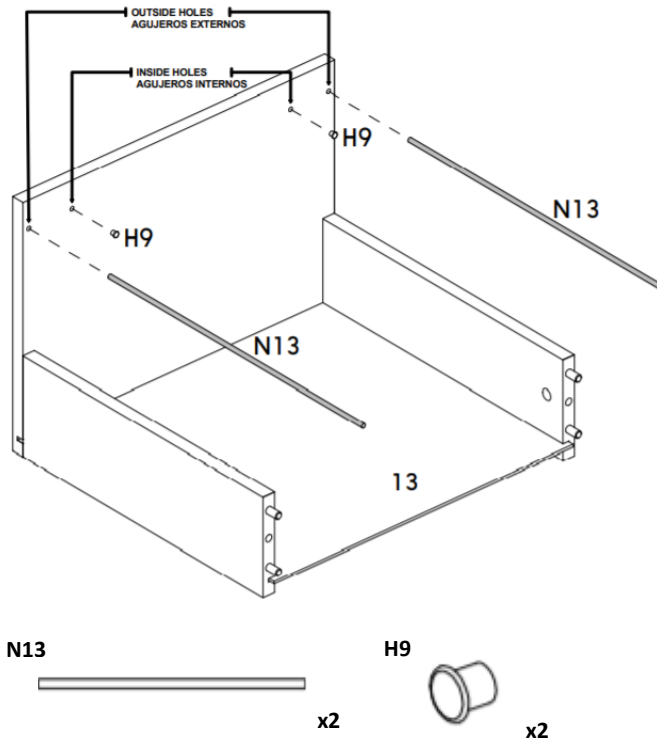

Note: choose the appropriate hole for your papers. Use the external holes for big files and internal holes for small files.
Nota: elija el agujero apropiado para sus papeles. Utilice los agujeros externos para los archivos grandes e internos para archivos pequeños.

21. Fix **front of large drawer (7)**, **handle (O2)** and **plastic hole plugs (H9)** to previous assembly.
 Fijar **frontal de cajón grande (7)**, **manilla (O2)** y **taponos plásticos (H9)** a ensamble previo.

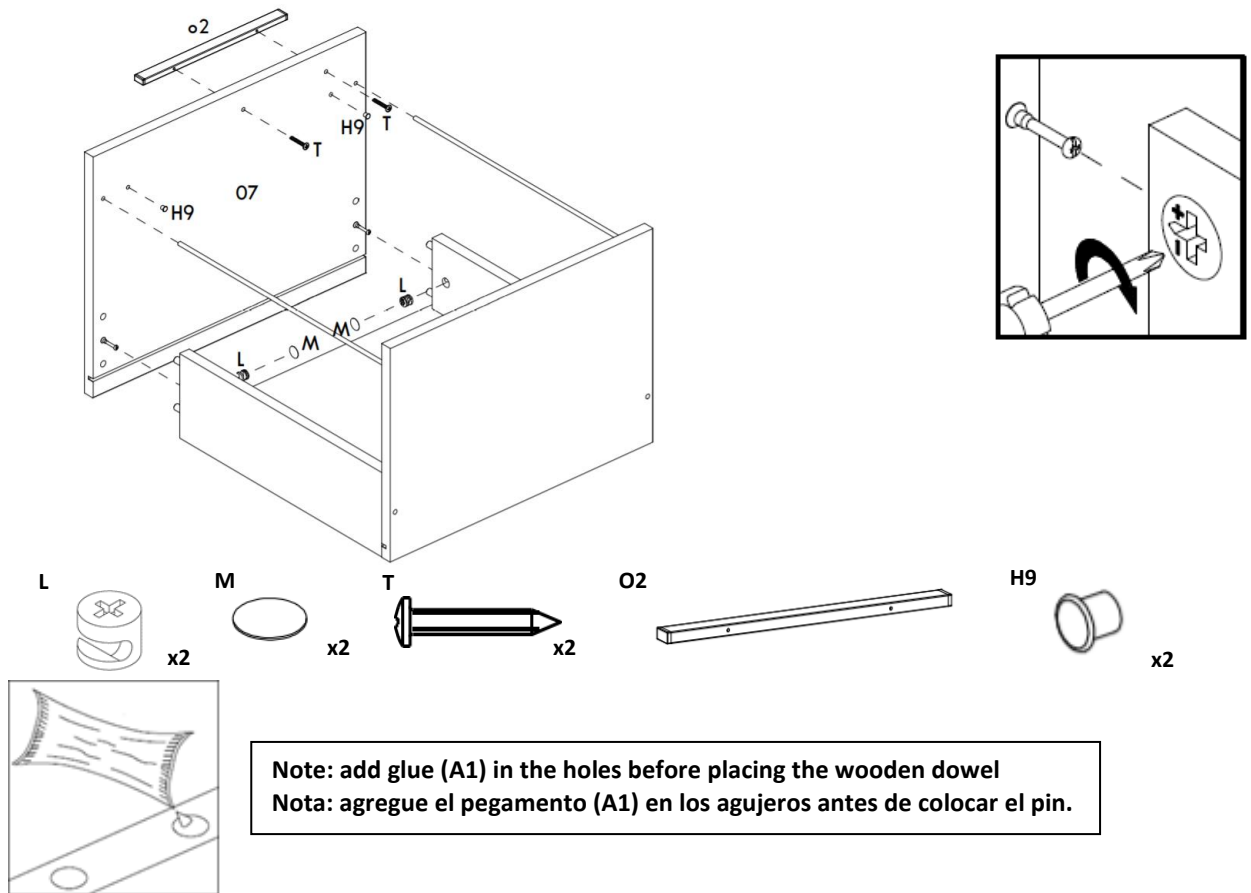

22. Fix **left drawer slide (VC)** and **right drawer slide (VD)** to previous assembly.
 Fijar **corredera de cajón izquierdo (VC)** y **corredera de cajón derecho (VD)** a ensambles previo.

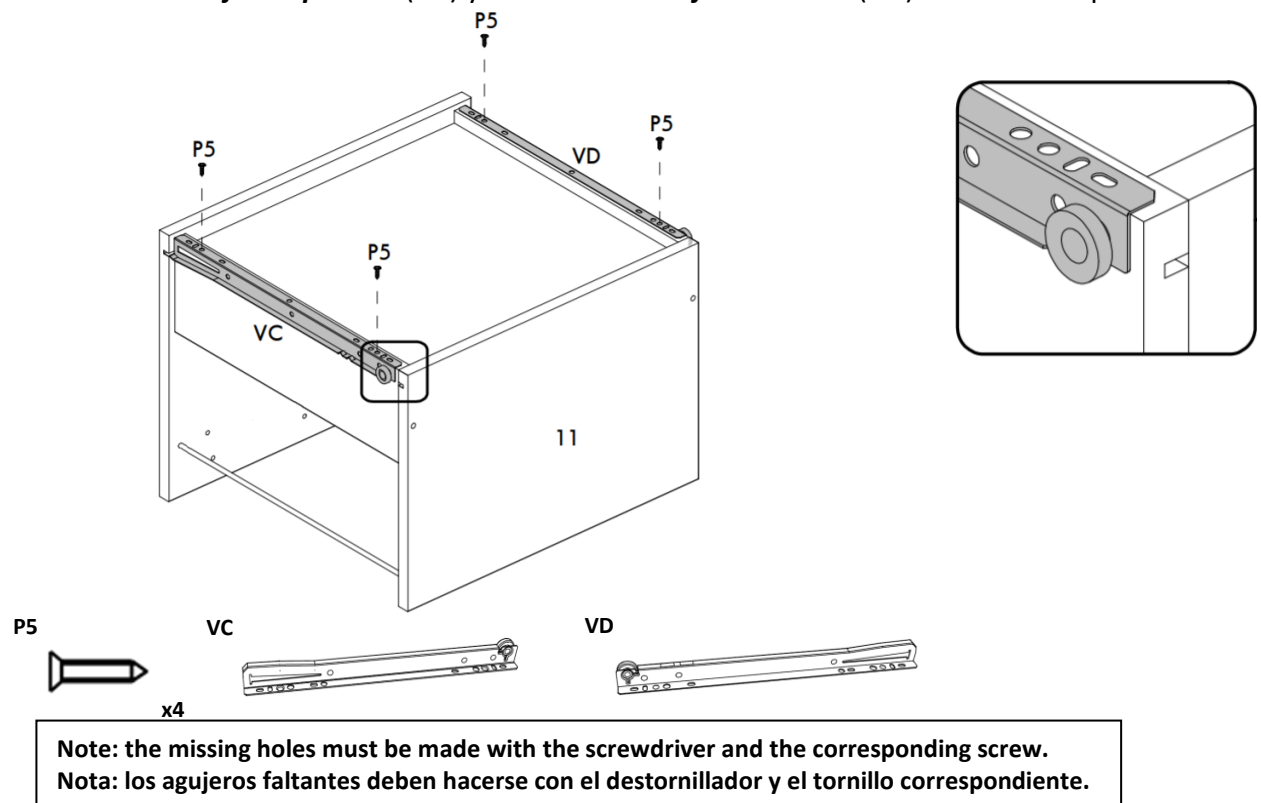

Need some Help? Call +1 (787) 688-1254 or email contact@boahaus.com
 ¿Necesitas ayuda? Llama +1 (787) 688-1254 o envía un email contact@boahaus.com

23. And finally place drawers in the furniture.
Y finalmente colocar cajones en el mueble.

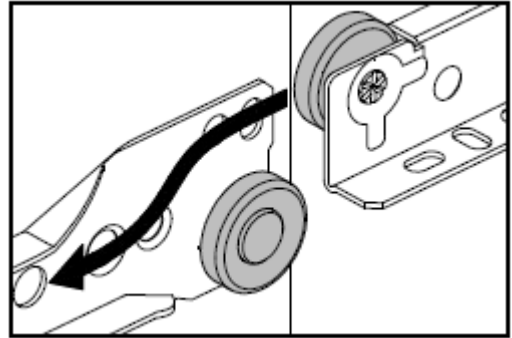
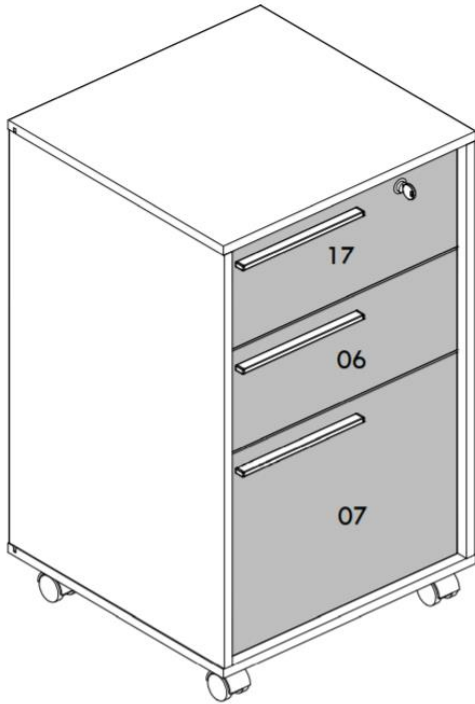

***Congratulations, you have assembled your FILE CABINET!!!
¡¡¡Felicitaciones, has armado tu Archivador!!!***

4305 Boahaus File Cabinet Warranty**6-Months Limited Warranty**

1. Boahaus, LLC provides limited warranty coverage to the original purchaser of this product for a period of six months from the date of purchase against defects in materials or workmanship of Boahaus furniture components. As used in this Warranty, “defect” means imperfections in components which substantially impair the utility of the product. This Warranty gives you specific legal rights, and you may also have other rights which vary from state to state.
2. There is no warranty coverage for defects or conditions that result from the failure to follow product assembly instructions, information or warnings, misuse or abuse, intentional damage, fire, flood, alteration or modification of the product, or use of the product in a manner inconsistent with its intended use, nor any condition resulting from incorrect or inadequate maintenance, cleaning, or care. There is also no warranty coverage for rented products or any products purchased “used” or “as is”, at a distress or going-out-of business sale, or from a liquidator.
3. As the exclusive remedy under this Warranty, Boahaus will (at its sole option) repair, replace or refund the value of any defective furniture component. Boahaus may require independent confirmation of the claimed defect and proof of purchase. Replacement parts will be warranted for only the remaining period of the original Warranty. BOAHAUS SHALL HAVE NO LIABILITY for ANY INCIDENTAL OR CONSEQUENTIAL DAMAGES OF ANY KIND and all such damages are EXCLUDED FROM THIS WARRANTY, such as loss of use, disassembly, transportation, labor or damage to property on or near the product. Some states do not allow the exclusion or limitation of incidental or consequential damages, so the above limitation or exclusion may not apply to you.
4. This Warranty applies only to warranted defects that first arise and are reported to Boahaus within the warranty coverage period. The Warranty cannot be transferred to subsequent owners or users of the product, and it shall be immediately void in the event the product is resold, transferred, leased or rented to any third party or person other than the original purchaser.
5. THERE ARE NO OTHER WARRANTIES APPLICABLE TO THIS PRODUCT. Under the laws of certain states, there may be no implied warranties from Boahaus and all implied warranties, INCLUDING ANY IMPLIED WARRANTY OF MERCHANTABILITY OR FITNESS FOR A PARTICULAR PURPOSE are disclaimed where allowed by law. TO THE EXTENT ANY IMPLIED WARRANTIES ARE APPLICABLE, ANY IMPLIED WARRANTIES, INCLUDING ANY IMPLIED WARRANTY OF MERCHANTABILITY OR FITNESS FOR A PARTICULAR PURPOSE, ARE LIMITED IN DURATION TO THE DURATION OF THIS EXPRESS WARRANTY or the minimum period allowed by law, whichever is shorter. Some states do not allow limitations on how long an implied Warranty lasts, so the above limitation may not apply to you.
6. For Warranty inquiries, questions about disposition or claims, please visit our website www.boahaus.com. You can also contact Boahaus at +1 (787) 688-1254 or email at administracion@boahaus.com. Boahaus may require Warranty claims to be submitted in writing to:

Boahaus LLC.
1250-1252
Ave. Franklin Delano Roosevelt,
San Juan, PR 00926.

Please include your sales receipt or other proof of purchase and a specific description of the product defect.

Garantía de Archivador 4305 Boahaus**Garantía limitada de 6 meses**

1. Boahaus, LLC proporciona cobertura de garantía limitada al comprador original de este producto por un período de 6 meses a partir de la fecha de compra contra defectos en materiales o mano de obra de componentes de muebles de Boahaus. Como se especifica en esta Garantía, "defecto" significa imperfecciones en componentes que perjudican sustancialmente la utilidad del producto. Esta Garantía le otorga derechos legales específicos y también puede tener otros derechos que varían de un estado a otro.
2. No hay cobertura de garantía por defectos o condiciones que resulten del incumplimiento de las instrucciones del producto, o advertencias, uso indebido o abuso, daño intencional, incendio, inundación, alteración o modificación del producto o uso del producto de manera inconsistente con su uso previsto, o cualquier condición resultante de mantenimiento incorrecto o inadecuado, limpieza o cuidado. Tampoco hay cobertura de garantía para productos alquilados o cualquier producto comprado "usado" o "tal cual", en una venta de emergencia o de salida de la empresa, o de un liquidador.
3. Boahaus puede requerir una confirmación independiente del defecto reclamado y un comprobante de compra. Las piezas de repuesto estarán garantizadas durante el período restante de la garantía original. BOAHAUS NO TENDRÁ NINGUNA RESPONSABILIDAD POR CUALQUIER DAÑO INCIDENTAL y todos estos daños ESTÁN EXCLUIDOS DE ESTA GARANTÍA, tales como pérdida de uso, desmontaje, transporte, mano de obra o daños a la propiedad en o cerca del producto. Algunos estados no permiten la exclusión o limitación de daños incidentales o consecuentes, por lo que la limitación o exclusión anterior puede no aplicarse a usted.
4. Esta Garantía se aplica únicamente a los defectos garantizados que surgen y se informan a Boahaus dentro del período de cobertura de la garantía. La garantía no puede ser transferida a los propietarios o usuarios posteriores del producto, y será inmediatamente nula en caso de que el producto sea revendido, transferido, arrendado o alquilado a cualquier tercero o persona que no sea el comprador original.
5. NO HAY OTRAS GARANTÍAS APLICABLES A ESTE PRODUCTO. Bajo las leyes de ciertos estados, no puede haber garantías implícitas de Boahaus y todas las garantías implícitas, INCLUYENDO CUALQUIER GARANTÍA IMPLÍCITA DE COMERCIABILIDAD O ADECUACIÓN PARA UN PROPÓSITO EN PARTICULAR, están exoneradas cuando permitido por la ley. TODAS LAS GARANTÍAS IMPLÍCITAS SON APLICABLES, LAS GARANTÍAS IMPLÍCITAS, INCLUIDAS CUALQUIER GARANTÍA IMPLÍCITA DE COMERCIABILIDAD O ADECUACIÓN PARA UN PROPÓSITO PARTICULAR, ESTÁN LIMITADAS EN DURACIÓN A LA DURACIÓN DE ESTA GARANTÍA EXPRESA o el período mínimo permitido por la ley, cualquiera que sea más corto. Algunos estados no permiten limitaciones sobre la duración de una garantía implícita, por lo que es posible que la limitación anterior no se aplique a usted.
6. Para consultas sobre la garantía, preguntas sobre la disposición o reclamaciones, visite nuestro sitio web www.boahaus.com. También puede ponerse en contacto con Boahaus en +1 (787) 688-1254 o por correo electrónico en administracion@boahaus.com. Boahaus puede requerir que los reclamos de garantía sean presentados por escrito a:

Boahaus LLC.
1250-1252
Ave. Franklin Delano Roosevelt,
San Juan, PR 00926.

Incluya su recibo de compra u otra prueba de compra y una descripción específica del defecto del producto.