

BoatHaus

ASSEMBLY INSTRUCTIONS

ATTENTION!!!

Any inquiry or replacement parts
you need, contact us directly at:

contact@boahaus.com

Scan this QR Code to chat to Customer Support Team.



Or Call Us at +1 (787) 688-1254

BoaHaus

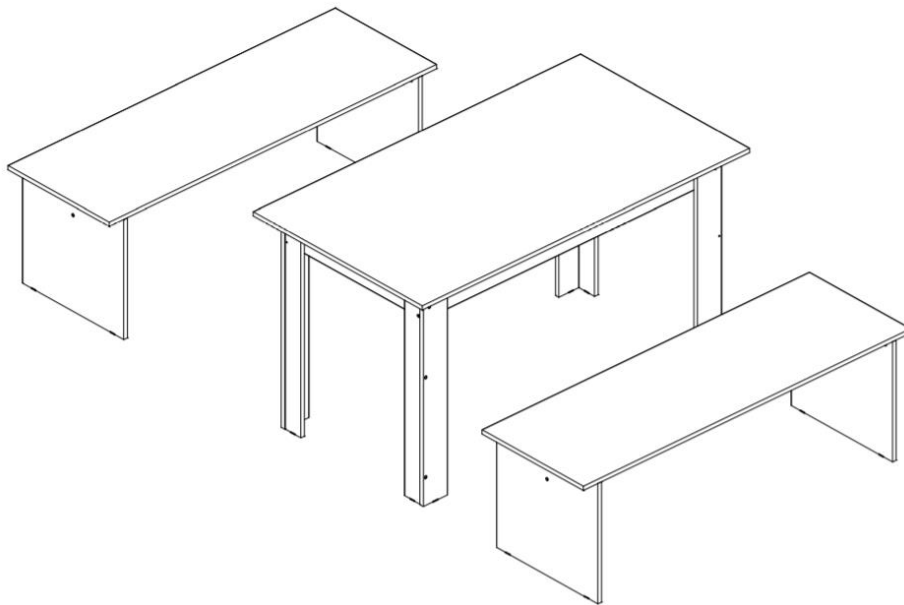
ASSEMBLY INSTRUCTIONS**INSTRUCCIONES DE ARMADO****MODEL #: 3301****DINING SET****Juego de Comedor**

Aprox. product weight 96.98 lbs. / 43,99 Kg. *

***Weight may vary +/- 5%.**

Lot: See package

Production date: See package

Purchase date: _____

THIS INFORMATION BOOKLET CONTAINS IMPORTANT SAFETY INFORMATION. PLEASE READ AND KEEP FOR FUTURE REFERENCE.
ESTE FOLLETO CONTIENE INFORMACIÓN DE SEGURIDAD IMPORTANTE. POR FAVOR, LEA Y GUÁRDELO PARA REFERENCIA FUTURA.

Need some Help? Call +1 (787) 688-1254 or email contact@boahaus.com
¿Necesitas ayuda? Llama +1 (787) 688-1254 o envía un email contact@boahaus.com

Need some Help? Call +1 (787) 688-1254 or email contact@boahaus.com
¿Necesitas ayuda? Llama +1 (787) 688-1254 o envía un email contact@boahaus.com

GENERAL SAFETY INFORMATION

1. Please read the Assembly Instructions prior to assembling this product.
2. Remove all the hardware from the box and sort by type.
3. Check to see that all the hardware and parts are present BEFORE assembling.
4. To avoid damage, assemble the product on a sturdy, level and protective surface.
5. Please wait until all steps are completed before fully tightening bolts.
6. Make sure all bolts are tightly fastened before the unit is used.
7. To move the product, you must lift it. DO NOT drag it, if you drag it can cause overturning.

INFORMACIÓN GENERAL DE SEGURIDAD

1. Lea las instrucciones de armado antes de ensamblar este producto.
2. Extraiga todo el hardware de la caja y ordene por tipo.
3. Verifique que todo el hardware y las piezas están presentes ANTES de ensamblar.
4. Para evitar daños, ensamble el producto sobre una superficie resistente, nivelada y con protección.
5. Espere hasta que todos los pasos se hayan completado antes de apretar completamente los tornillos y accesorios.
6. Asegúrese de que todos los tornillos y accesorios estén bien apretados antes de usar la unidad.
7. Para mover el producto debe levantarlo. NO lo arrastre, si lo arrastra puede causar volcamiento.



General Dimensions / Dimensiones Generales

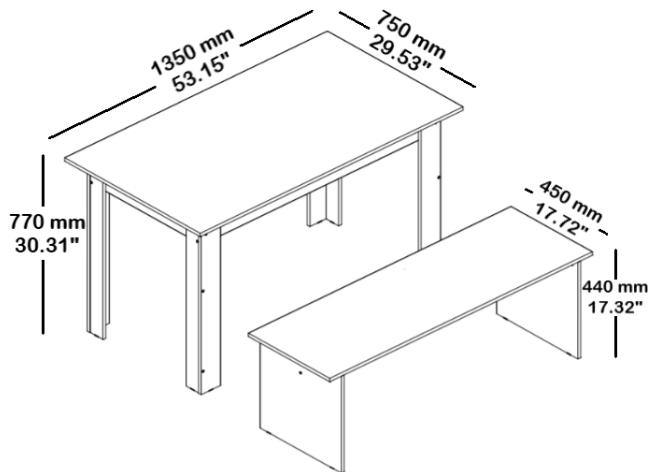

Maximum weight supported / Peso máximo soportado

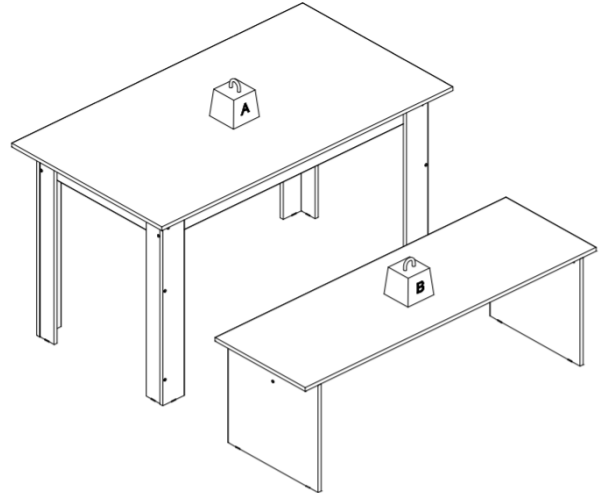

	LB	KG
A	110	50
B	330	150

Weight in pounds. / Peso en libras.

Note: weight must be evenly distributed.

Nota: el peso debe estar distribuido

You will need / usted necesitará:

Tools not included / herramientas no incluidas



2 people
2 personas

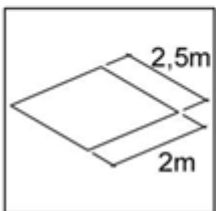

Recommended space for assembly
Espacio recomendado para el armado

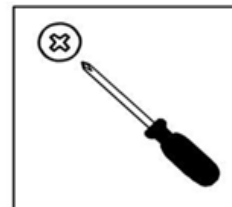







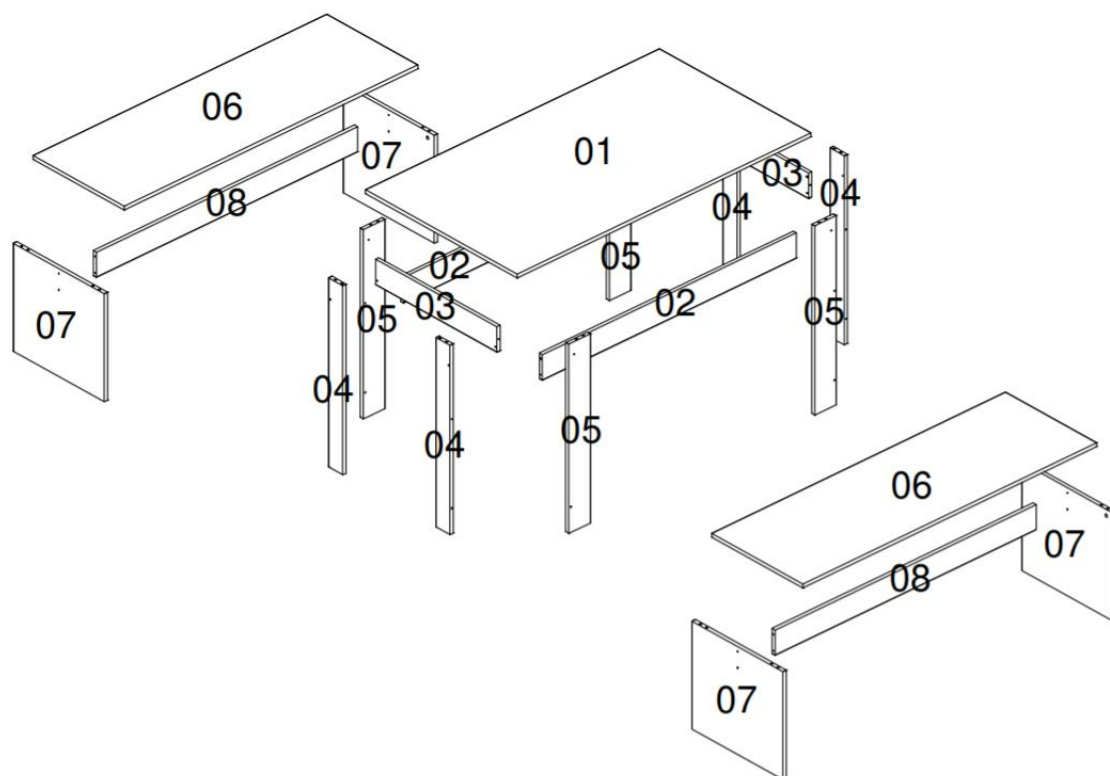

Note: Place a carpet or blanket in the assembly area to avoid damage to the parts during the process.
Nota: Colocar una alfombra o manta en el area de armado para evitar daños en las piezas durante el proceso.

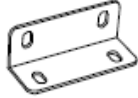
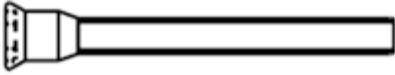
PARTS IDENTIFICATION / IDENTIFICACION DE PARTES

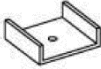
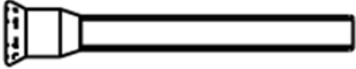
Nº	DESCRIPTION - DESCRIPCIÓN	QTY.
1	Table top base / Base superior de mesa	1
2	Table front tray / Travesaño frontal de mesa	2
3	Table side tray / Travesaño lateral de mesa	2
4	Side foot / Pie lateral	4
5	Front foot / Pie frontal	4
6	Bench top base / Base superior de banco	2
7	Bench side / Lateral de banco	4
8	Bench tray / Travesaño de banco	2

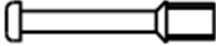

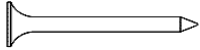
IDENTIFICATION OF ACCESSORIES / IDENTIFICACION DE ACCESORIOS

NUMBER		DESCRIPTION	QTY
B5		Metallic angle plates / Soporte de metal	14
C16		Structural screw / Tornillo estructural (5 x 60 mm)	4
E		Wooden dowel / Pin (8 x 30 mm)	28
E7		Plastic foot / Pie plástico	16
G		Structural screw / Tornillo estructural (5 x 50 mm)	20
H		Allen key / Llave allen	1
I		Structural screw cover / Tapa de tornillo estructural	24
J		Simple minifix screw / Tornillo minifix simple	8
L		Drum lock / Tambor minifix	8
M		Adhesive bore patch / Tapón adhesivo	8
N		Nail / Clavo	16
S		Pan head screw / Tornillo cabeza redondeada (3,5 x 14 mm)	56

PRE-ASSEMBLY / PRE- ARMADO

1. Fix **simple minifix screw** (J) to **bench top base** (6) x2.
Fijar **tornillo minifix simple** (J) a **base superior de banco** (6) x2.

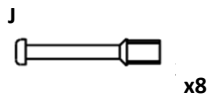
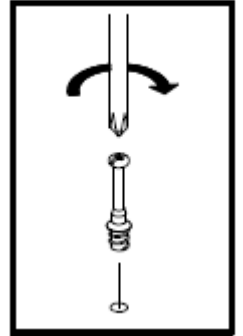
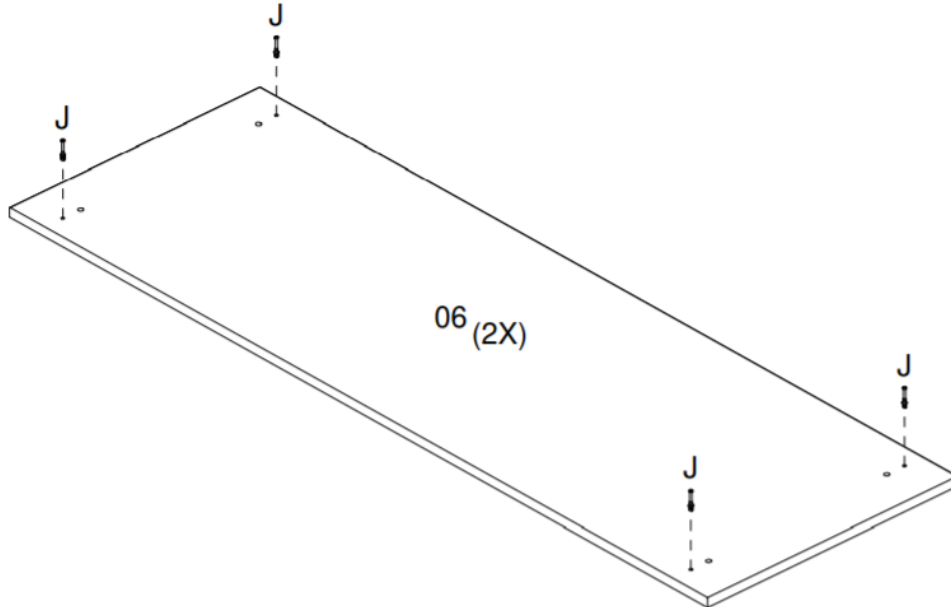

2. Fix **wooden dowel** (E) to **bench side** (7) x4.
Fijar **pin** (E) a **lateral de banco** (7) x4.

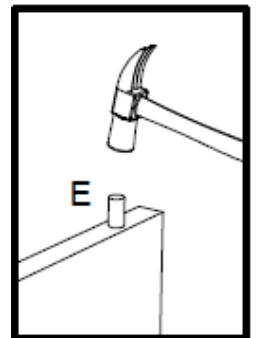
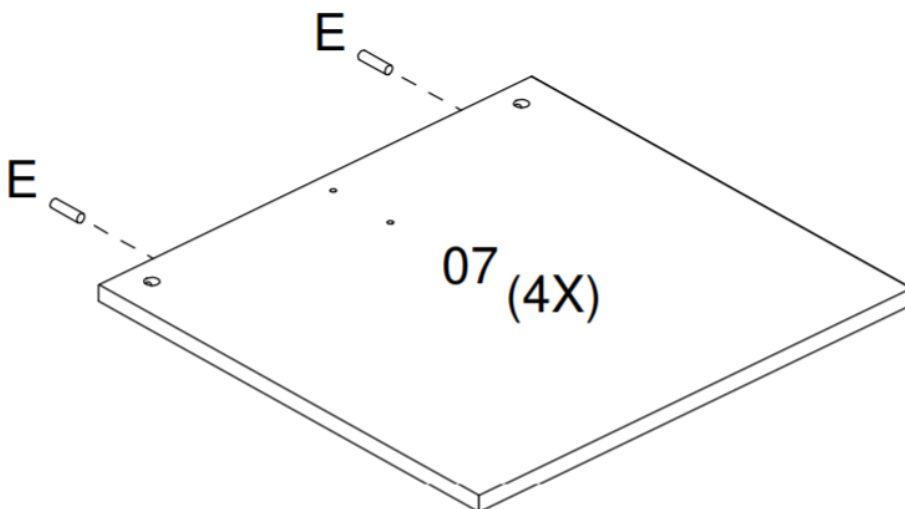

3. Fix **wooden dowel** (E) to **side foot** (4) x4 and **front foot** (5) x4.
 Fijar **pin** (E) a **pie lateral** (4) x4 y **pie frontal** (5) x4.

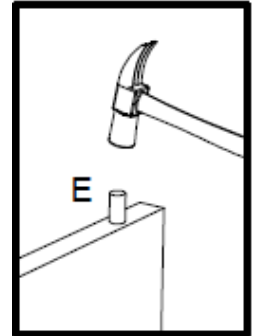
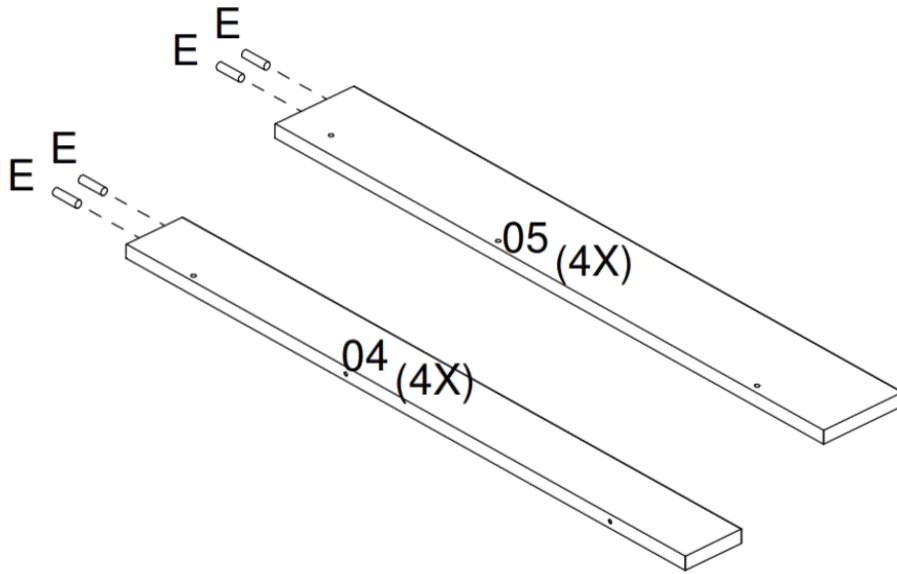

4. Fix **wooden dowel** (E) to **table front tray** (2) x2.
 Fijar **pin** (E) a **travesaño frontal de mesa** (2) x2.

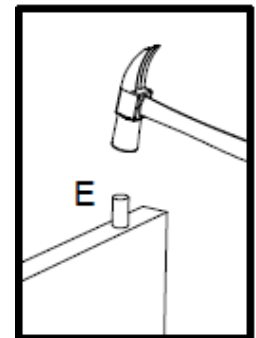
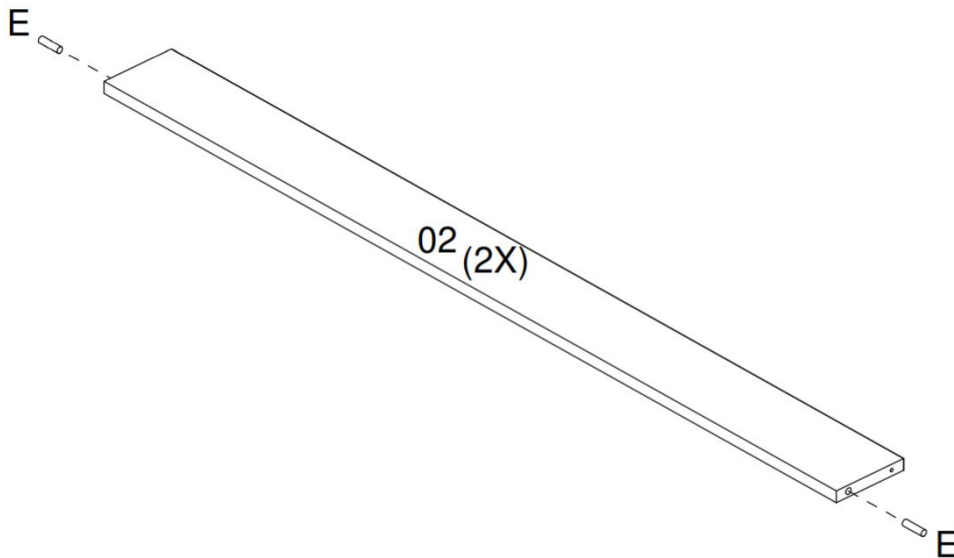

ASSEMBLY / ARMADO

5. Fix **bench tray** (8) x2 to **bench side** (8) x2.
 Fijar **travesaño de banco** (8) x2 a **lateral de banco** (8) x2.

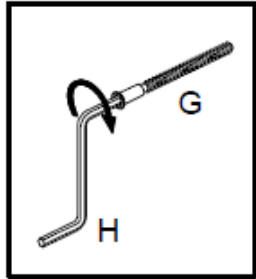
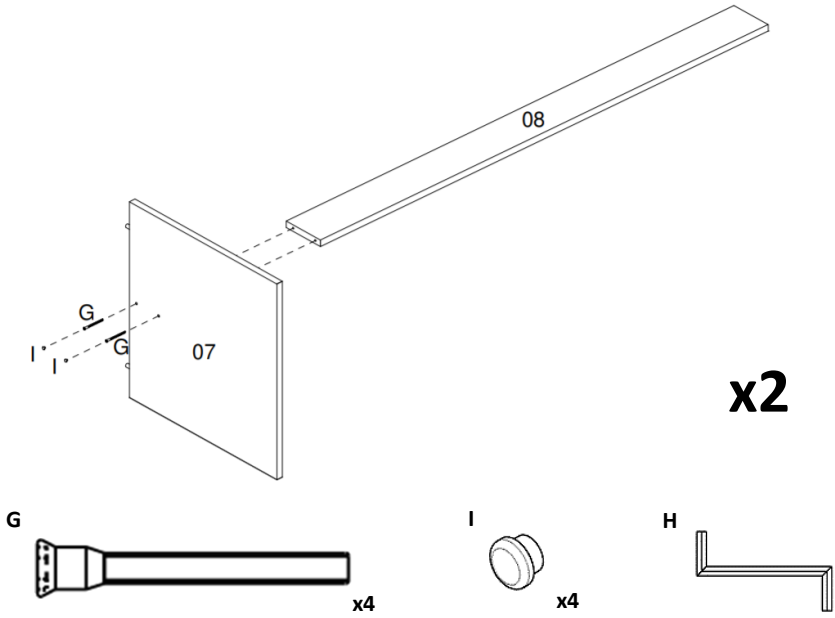

Note: use the allen key (H) to adjust the structural screws (G).
Nota: usar la llave allen (H) para ajustar los tornillos estructurales (G).

6. Fix **bench side** (7) x2 to previous assembly x2.
 Fijar **lateral de banco** (7) x2 a ensamble previo x2.

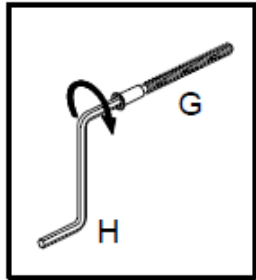
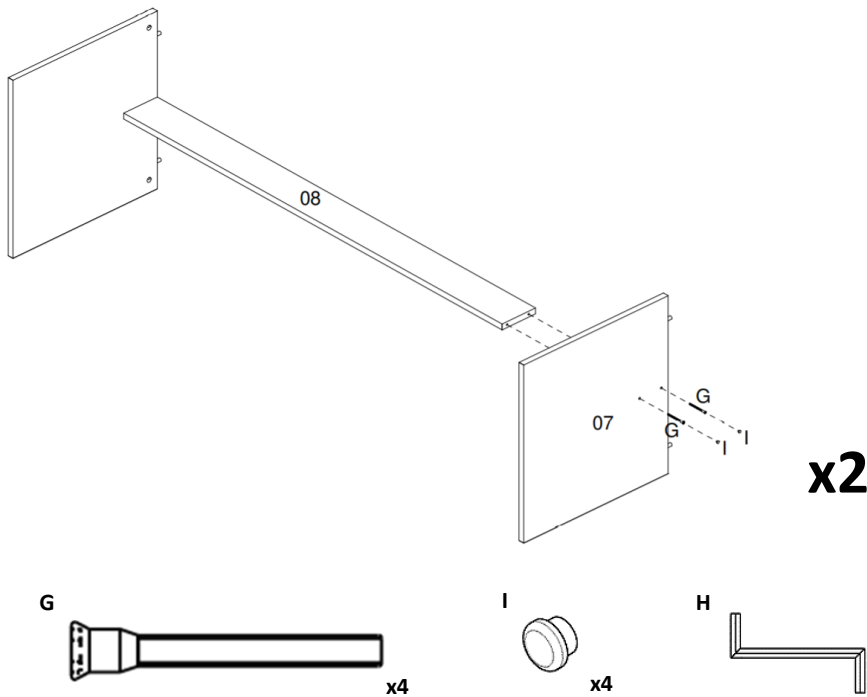

Note: use the allen key (H) to adjust the structural screws (G).
Nota: usar la llave allen (H) para ajustar los tornillos estructurales (G).

7. Fix **bench top base** (6) x2 to previous assembly.
 Fijar **base superior de banco** (6) x2 a ensamble previo.

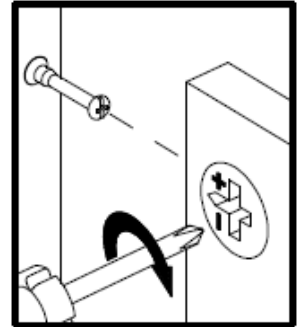
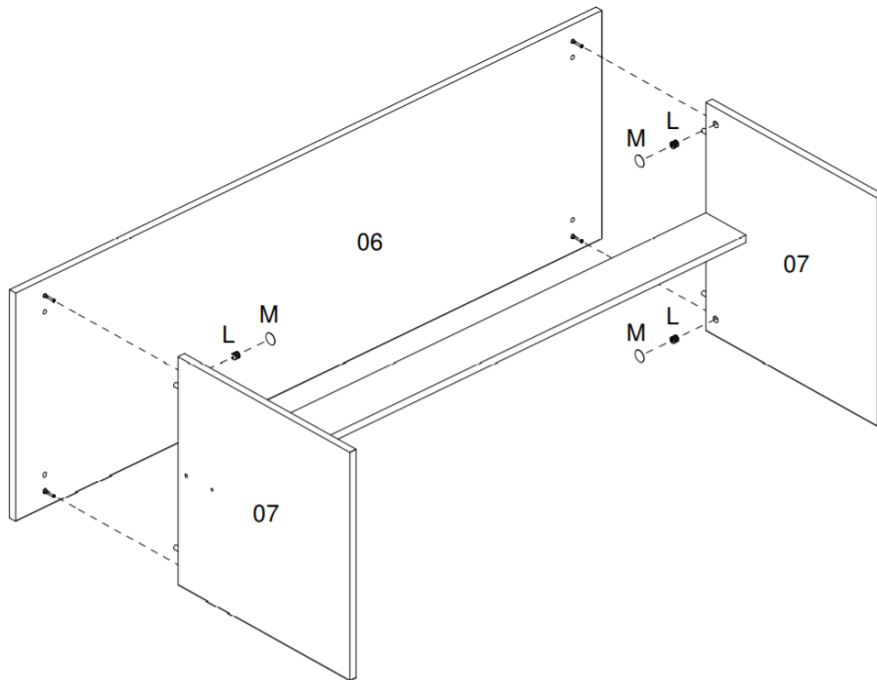

8. Fix previous assembly x2 with **metallic angle plate** (B5).
 Fijar ensamble previo x2 con **soporte de metal** (B5).

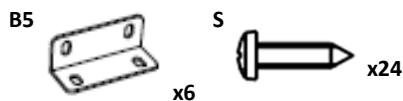
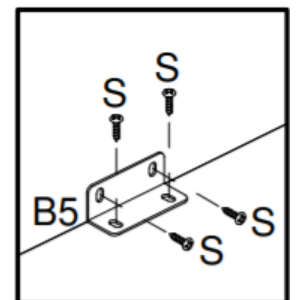
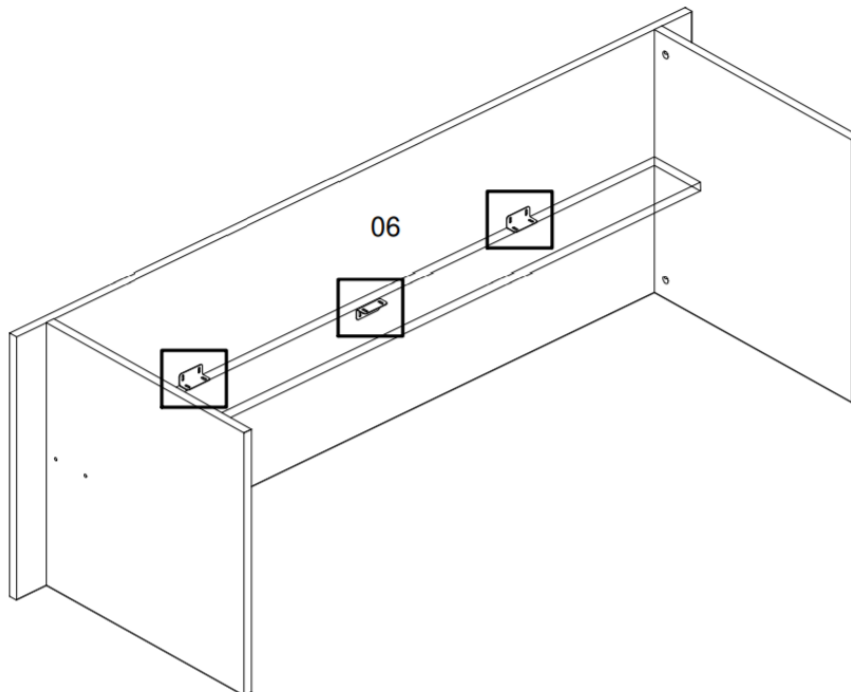

9. Fix **plastic foot** (E7) to previous assembly x2.
 fijar **pie plástico** (E7) a ensamble previo x2.

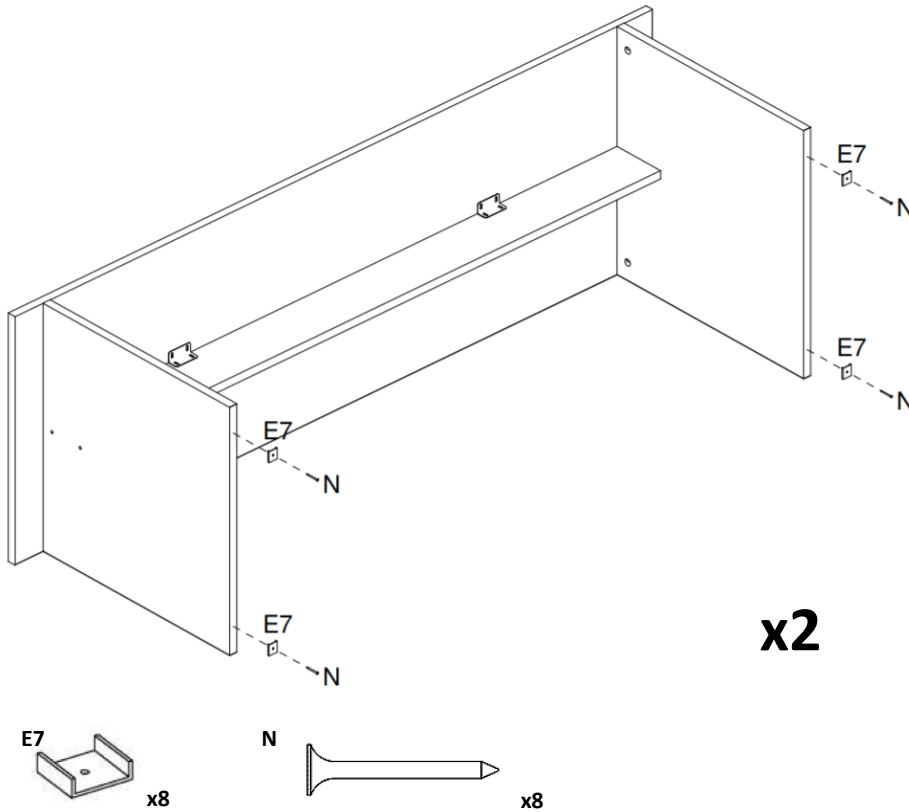

10. Fix **table front tray** (2) to **table side tray** (3).
 Fijar **travesaño frontal de mesa** (2) a **travesaño lateral de mesa** (3).

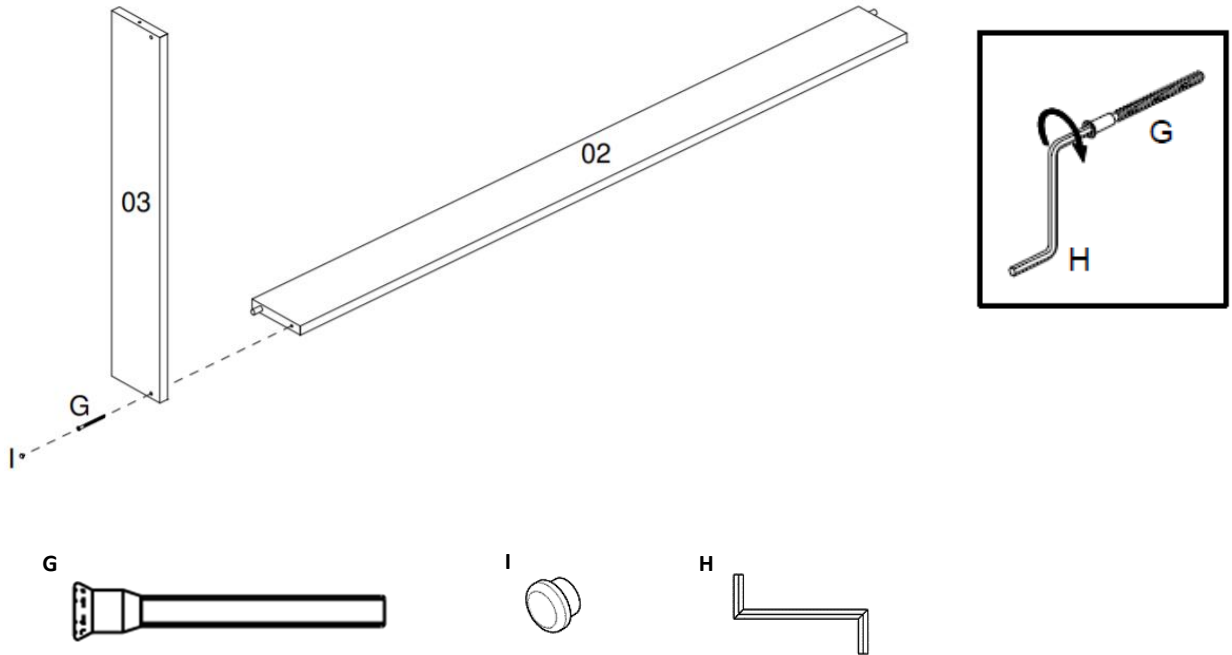

Note: use the allen key (H) to adjust the structural screws (G).
 Nota: usar la llave allen (H) para ajustar los tornillos estructurales (G).

11. Fix **table front side** (2) to previous assembly.
 Fijar **travesaño frontal de mesa** (2) a ensamble previo.

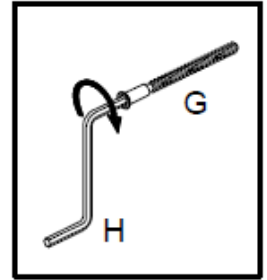
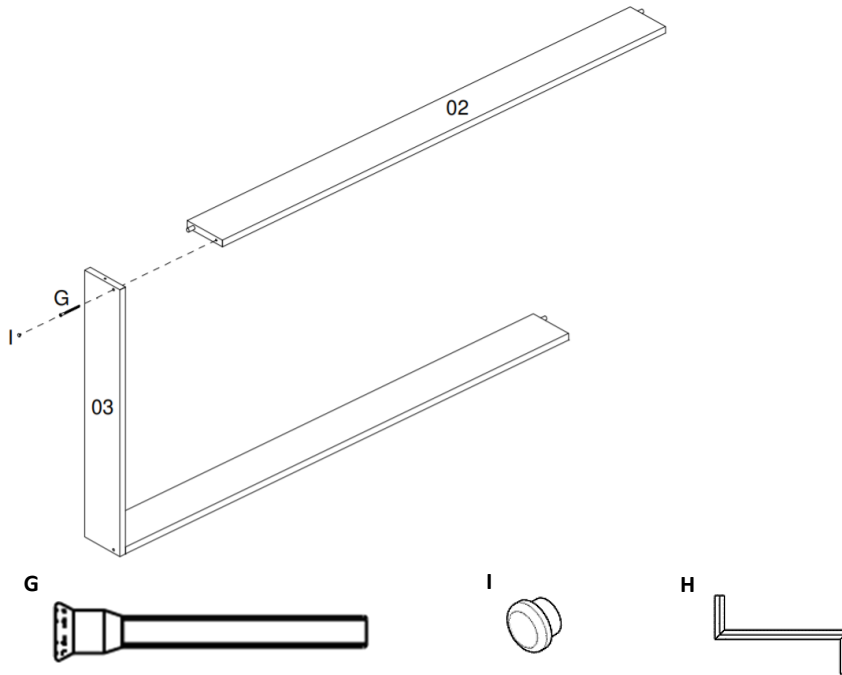

Note: use the allen key (H) to adjust the structural screws (G).
Nota: usar la llave allen (H) para ajustar los tornillos estructurales (G).

12. Fix **table side tray** (3) to previous assembly.
 Fijar **travesaño lateral de mesa** (3) a ensamble previo.

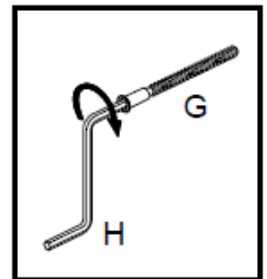
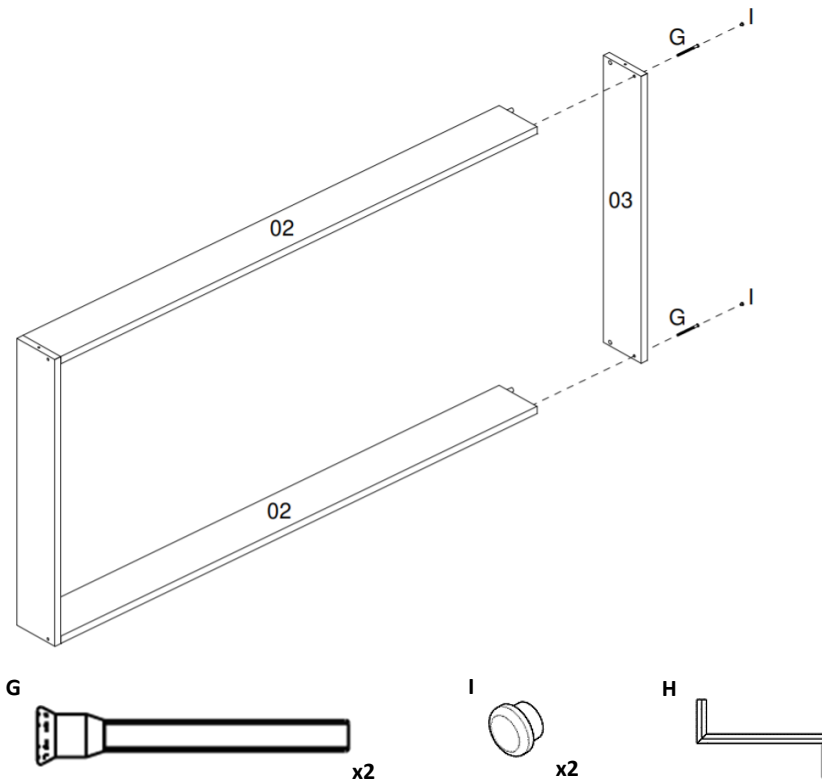

Note: use the allen key (H) to adjust the structural screws (G).
Nota: usar la llave allen (H) para ajustar los tornillos estructurales (G).

13. Fix *side foot* (4) x4 to *front foot* (5) x4.
 Fijar *pie lateral* (4) x4 a *pie frontal* (5) x4.

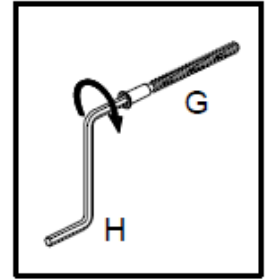
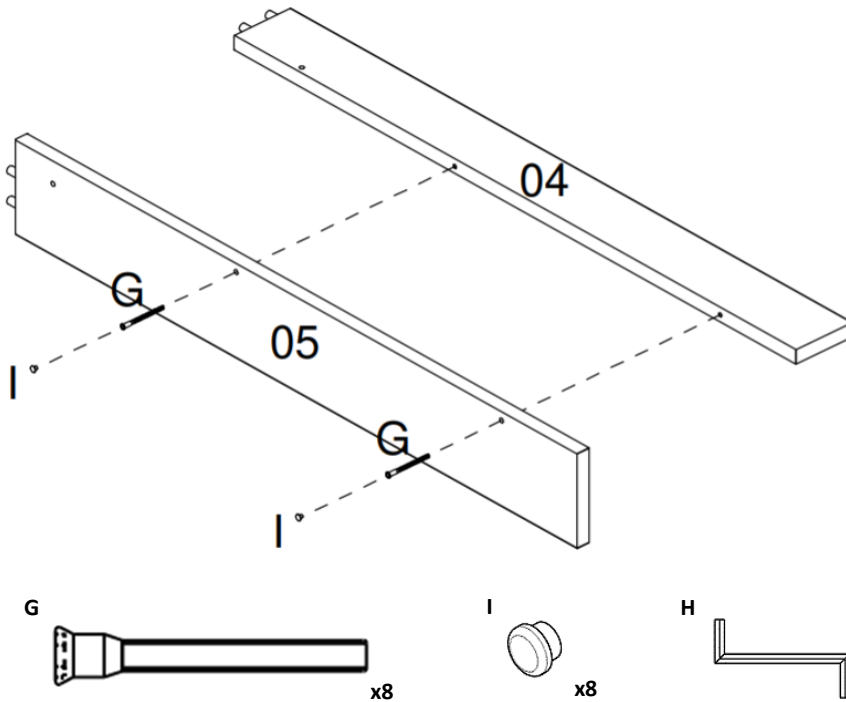

Note: use the allen key (H) to adjust the structural screws (G).
Nota: usar la llave allen (H) para ajustar los tornillos estructurales (G).

14. Fix both previous assemblies (steps 12 and 13).
 Fijar ambos ensambles previos (pasos 12 y 13).

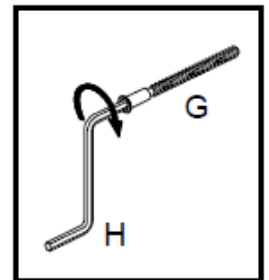
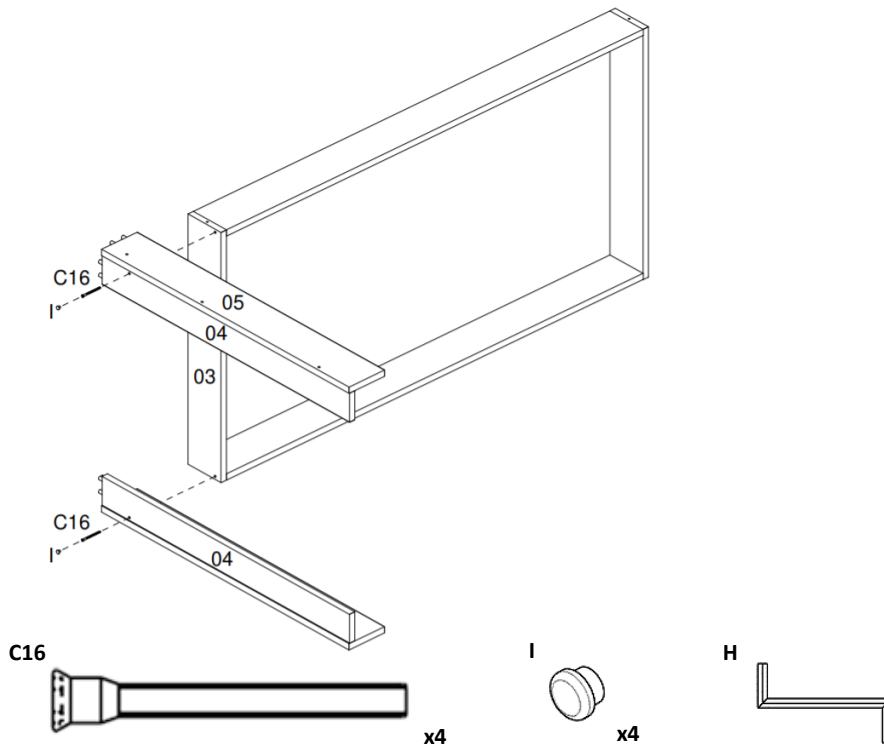

Note: use the allen key (H) to adjust the structural screws (G).
Nota: usar la llave allen (H) para ajustar los tornillos estructurales (G).

15. Fix both previous assemblies (steps 13 and 14).
 Fijar ambos ensambles previos (paso 13 y 14).

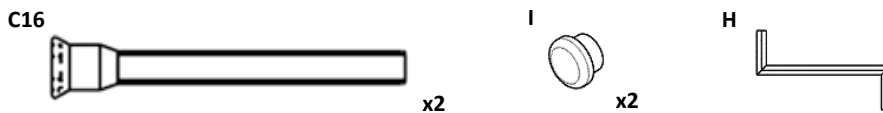
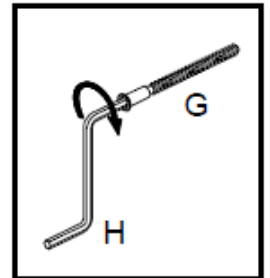
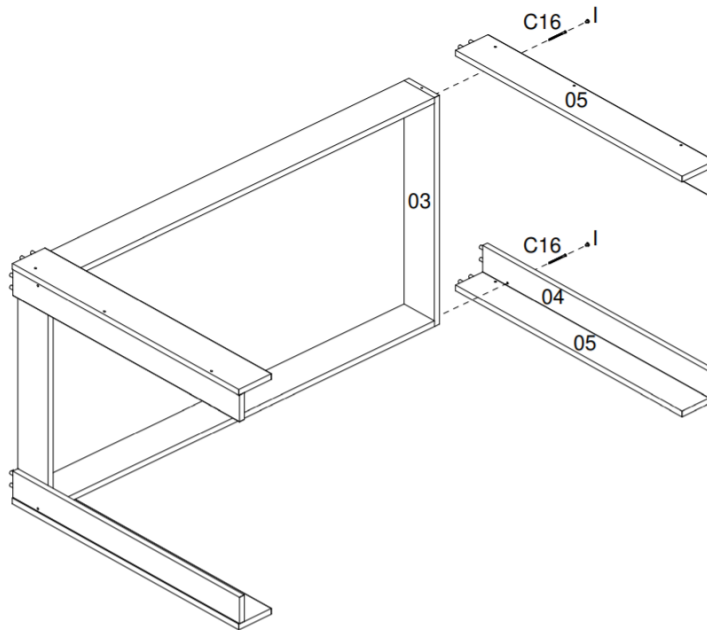

Note: use the allen key (H) to adjust the structural screws (G).
Nota: usar la llave allen (H) para ajustar los tornillos estructurales (G).

16. Fix **table top base** (1) to previous assembly.
 Fijar **base superior de mesa** (1) a ensamble previo

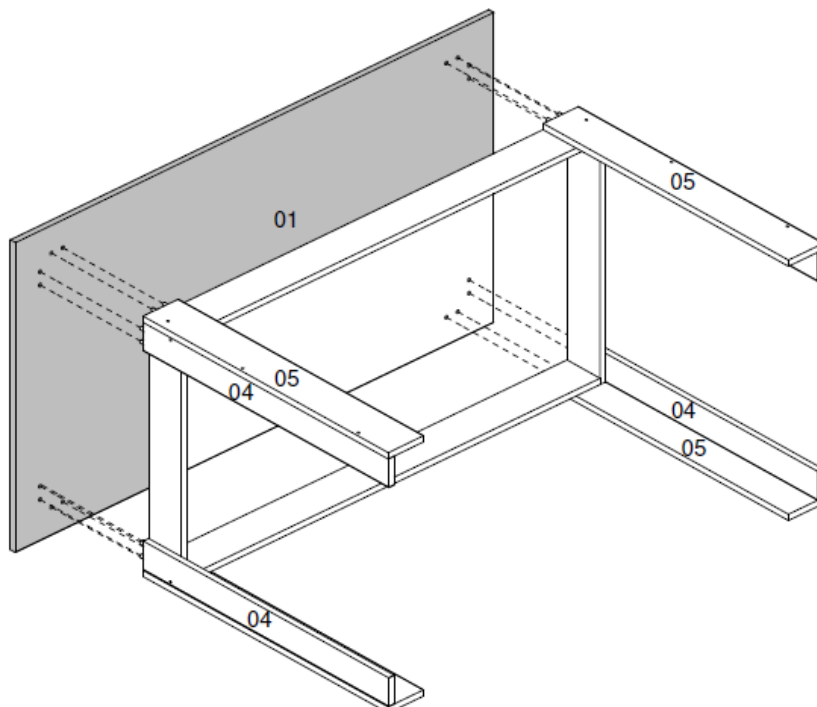

17. Fix **metallic angle plate** (B5) to previous assembly.
 Fijar **soporte de metal** (B5) a ensamble previo.

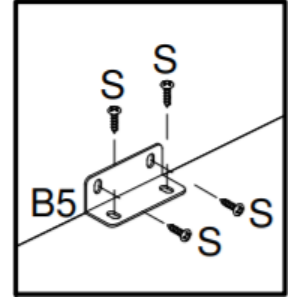
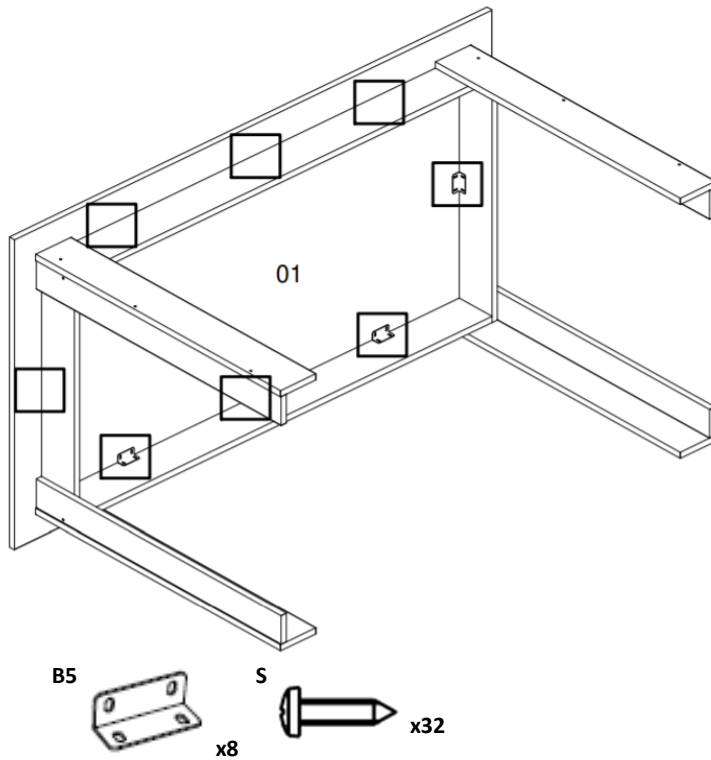

18. And finally, fix **plastic foot** (E7) to previous assembly.
 Y finalmente, fijar **pie plástico** (E7) a ensamble previo.

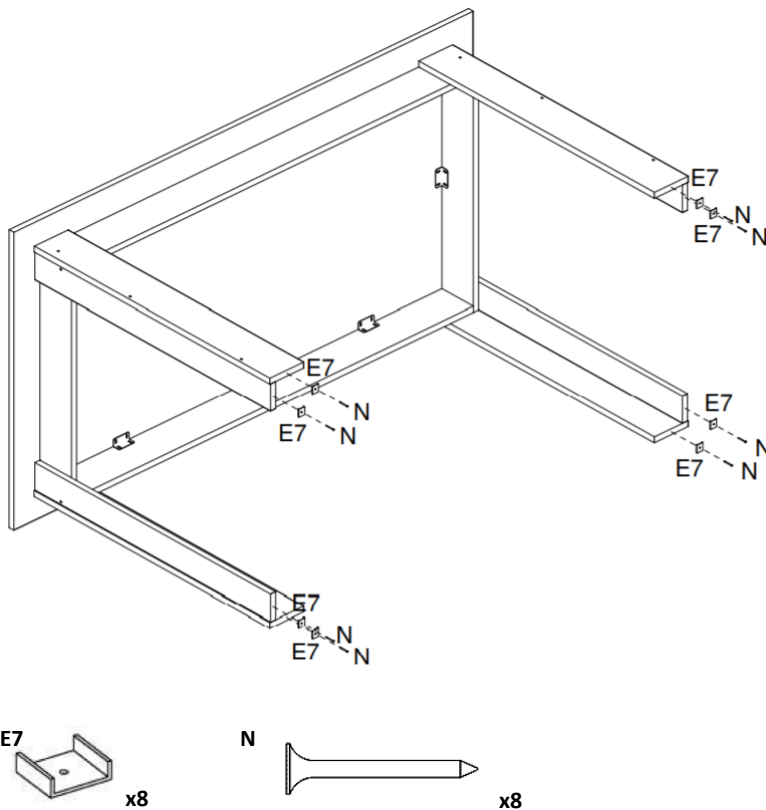

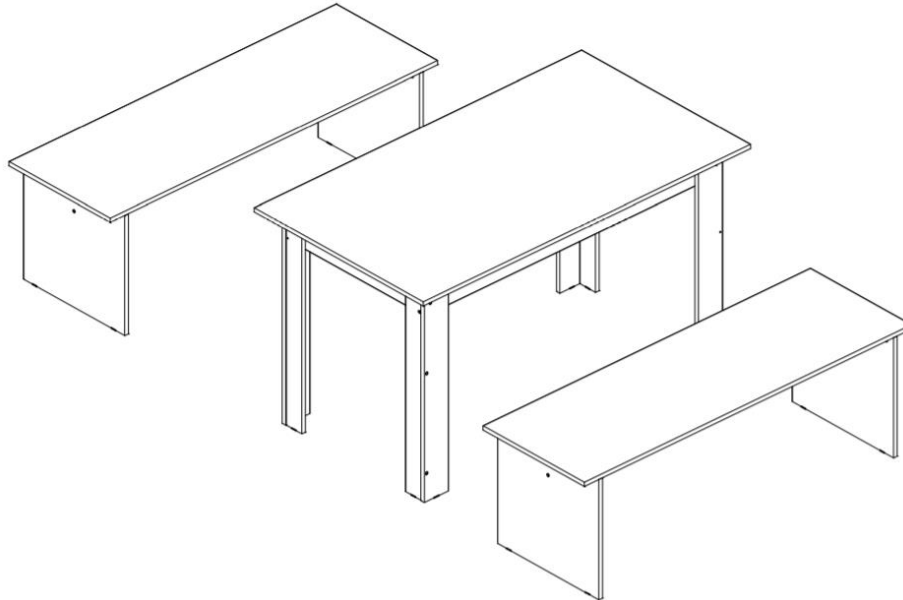

***Congratulations, you have assembled your DINING SET!!!
¡¡¡Felicitaciones, has armado tu Juego de Comedor!!!***

3301 Boahaus DINING SET Warranty**6-Months Limited Warranty**

1. Boahaus, LLC provides limited warranty coverage to the original purchaser of this product for a period of six months from the date of purchase against defects in materials or workmanship of Boahaus furniture components. As used in this Warranty, “defect” means imperfections in components which substantially impair the utility of the product. This Warranty gives you specific legal rights, and you may also have other rights which vary from state to state.
2. There is no warranty coverage for defects or conditions that result from the failure to follow product assembly instructions, information or warnings, misuse or abuse, intentional damage, fire, flood, alteration or modification of the product, or use of the product in a manner inconsistent with its intended use, nor any condition resulting from incorrect or inadequate maintenance, cleaning, or care. There is also no warranty coverage for rented products or any products purchased “used” or “as is”, at a distress or going-out-of business sale, or from a liquidator.
3. As the exclusive remedy under this Warranty, Boahaus will (at its sole option) repair, replace or refund the value of any defective furniture component. Boahaus may require independent confirmation of the claimed defect and proof of purchase. Replacement parts will be warranted for only the remaining period of the original Warranty. BOAHAUS SHALL HAVE NO LIABILITY for ANY INCIDENTAL OR CONSEQUENTIAL DAMAGES OF ANY KIND and all such damages are EXCLUDED FROM THIS WARRANTY, such as loss of use, disassembly, transportation, labor or damage to property on or near the product. Some states do not allow the exclusion or limitation of incidental or consequential damages, so the above limitation or exclusion may not apply to you.
4. This Warranty applies only to warranted defects that first arise and are reported to Boahaus within the warranty coverage period. The Warranty cannot be transferred to subsequent owners or users of the product, and it shall be immediately void in the event the product is resold, transferred, leased or rented to any third party or person other than the original purchaser.
5. THERE ARE NO OTHER WARRANTIES APPLICABLE TO THIS PRODUCT. Under the laws of certain states, there may be no implied warranties from Boahaus and all implied warranties, INCLUDING ANY IMPLIED WARRANTY OF MERCHANTABILITY OR FITNESS FOR A PARTICULAR PURPOSE are disclaimed where allowed by law. TO THE EXTENT ANY IMPLIED WARRANTIES ARE APPLICABLE, ANY IMPLIED WARRANTIES, INCLUDING ANY IMPLIED WARRANTY OF MERCHANTABILITY OR FITNESS FOR A PARTICULAR PURPOSE, ARE LIMITED IN DURATION TO THE DURATION OF THIS EXPRESS WARRANTY or the minimum period allowed by law, whichever is shorter. Some states do not allow limitations on how long an implied Warranty lasts, so the above limitation may not apply to you.
6. For Warranty inquiries, questions about disposition or claims, please visit our website www.boahaus.com. You can also contact Boahaus at +1 (787) 688-1254 or email at administracion@boahaus.com. Boahaus may require Warranty claims to be submitted in writing to:

Boahaus LLC.
1250-1252
Ave. Franklin Delano Roosevelt,
San Juan, PR 00926.

Please include your sales receipt or other proof of purchase and a specific description of the product defect.

Garantía de Juego de Comedor 3301 Boahaus**Garantía limitada de 6 meses**

1. Boahaus, LLC proporciona cobertura de garantía limitada al comprador original de este producto por un período de 6 meses a partir de la fecha de compra contra defectos en materiales o mano de obra de componentes de muebles de Boahaus. Como se especifica en esta Garantía, "defecto" significa imperfecciones en componentes que perjudican sustancialmente la utilidad del producto. Esta Garantía le otorga derechos legales específicos y también puede tener otros derechos que varían de un estado a otro.
2. No hay cobertura de garantía por defectos o condiciones que resulten del incumplimiento de las instrucciones del producto, o advertencias, uso indebido o abuso, daño intencional, incendio, inundación, alteración o modificación del producto o uso del producto de manera inconsistente con su uso previsto, o cualquier condición resultante de mantenimiento incorrecto o inadecuado, limpieza o cuidado. Tampoco hay cobertura de garantía para productos alquilados o cualquier producto comprado "usado" o "tal cual", en una venta de emergencia o de salida de la empresa, o de un liquidador.
3. Boahaus puede requerir una confirmación independiente del defecto reclamado y un comprobante de compra. Las piezas de repuesto estarán garantizadas durante el período restante de la garantía original. BOAHAUS NO TENDRÁ NINGUNA RESPONSABILIDAD POR CUALQUIER DAÑO INCIDENTAL y todos estos daños ESTÁN EXCLUIDOS DE ESTA GARANTÍA, tales como pérdida de uso, desmontaje, transporte, mano de obra o daños a la propiedad en o cerca del producto. Algunos estados no permiten la exclusión o limitación de daños incidentales o consecuentes, por lo que la limitación o exclusión anterior puede no aplicarse a usted.
4. Esta Garantía se aplica únicamente a los defectos garantizados que surgen y se informan a Boahaus dentro del período de cobertura de la garantía. La garantía no puede ser transferida a los propietarios o usuarios posteriores del producto, y será inmediatamente nula en caso de que el producto sea revendido, transferido, arrendado o alquilado a cualquier tercero o persona que no sea el comprador original.
5. NO HAY OTRAS GARANTÍAS APLICABLES A ESTE PRODUCTO. Bajo las leyes de ciertos estados, no puede haber garantías implícitas de Boahaus y todas las garantías implícitas, INCLUYENDO CUALQUIER GARANTÍA IMPLÍCITA DE COMERCIABILIDAD O ADECUACIÓN PARA UN PROPÓSITO EN PARTICULAR, están exoneradas cuando permitido por la ley. TODAS LAS GARANTÍAS IMPLÍCITAS SON APLICABLES, LAS GARANTÍAS IMPLÍCITAS, INCLUIDAS CUALQUIER GARANTÍA IMPLÍCITA DE COMERCIABILIDAD O ADECUACIÓN PARA UN PROPÓSITO PARTICULAR, ESTÁN LIMITADAS EN DURACIÓN A LA DURACIÓN DE ESTA GARANTÍA EXPRESA o el período mínimo permitido por la ley, cualquiera que sea más corto. Algunos estados no permiten limitaciones sobre la duración de una garantía implícita, por lo que es posible que la limitación anterior no se aplique a usted.
6. Para consultas sobre la garantía, preguntas sobre la disposición o reclamaciones, visite nuestro sitio web www.boahaus.com. También puede ponerse en contacto con Boahaus en +1 (787) 688-1254 o por correo electrónico en administracion@boahaus.com. Boahaus puede requerir que los reclamos de garantía sean presentados por escrito a:

Boahaus LLC.
1250-1252
Ave. Franklin Delano Roosevelt,
San Juan, PR 00926.

Incluya su recibo de compra u otra prueba de compra y una descripción específica del defecto del producto.