

boahaus

ASSEMBLY INSTRUCTIONS

ATTENTION!!!

Any inquiry or replacement parts
you need, contact us directly at:

contact@boahaus.com

Scan this QR Code to contact to Customer Support Team.



Or Call Us at +1 281-809-4043

boahaus

ASSEMBLY INSTRUCTIONS

INSTRUCCIONES DE ARMADO

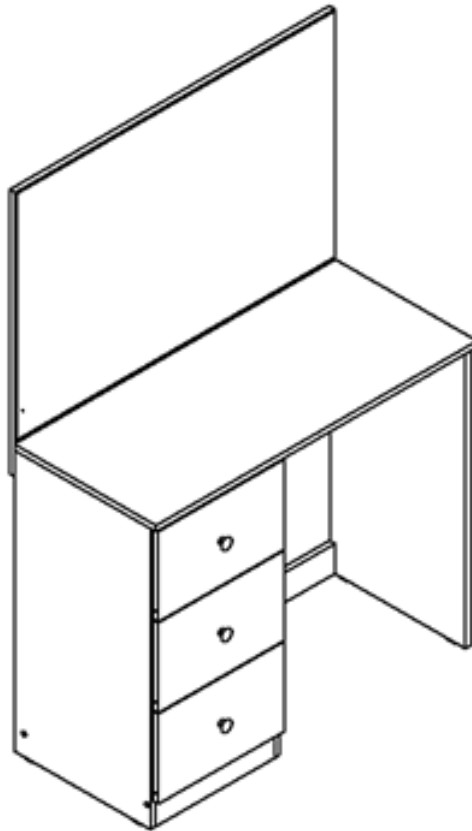

MODEL #: 1638

DRESSING TABLE WITH MIRROR

Tocador con espejo

Aprox. product weight 66 lbs. / 30 Kg. *

***Weight may vary +/- 5%**

Lot: See package

Production date: See package

Purchase date: _____

**THIS INFORMATION BOOKLET CONTAINS IMPORTANT SAFETY INFORMATION. PLEASE READ AND KEEP FOR FUTURE REFERENCE.
ESTE FOLLETO CONTIENE INFORMACIÓN DE SEGURIDAD IMPORTANTE. POR FAVOR, LEA Y GUÁRDELO PARA REFERENCIA FUTURA.**

**Need some Help? Call +1 281-809-4043 or email contact@boahaus.com
¿Necesitas ayuda? Llama +1 281-809-4043 o envía un email contact@boahaus.com**

GENERAL SAFETY INFORMATION

1. Please read the Assembly Instructions prior to assembling this product.
2. Remove all the hardware from the box and sort by type.
3. Check to see that all the hardware and parts are present BEFORE assembling.
4. To avoid damage, assemble the product on a sturdy, level and protective surface.
5. Please wait until all steps are completed before fully tightening bolts.
6. Make sure all bolts are tightly fastened before the unit is used.
7. To move the product, you must lift it. DO NOT drag it, if you drag it can cause overturning.
8. **This product is sold with a hardware kit to be fixed on the wall. You must install this kit to prevent any accidents or damages. When properly installed, this restrain can provide protection against the unexpected tipping of the unit due to small tremors, bumps or climbing. The restrain is only a deterrent and is not a substitute for proper adult supervision. Use of tip-over restraints may only reduce, but not eliminate, the risk of tip-over**

INFORMACIÓN GENERAL DE SEGURIDAD

1. Lea las instrucciones de armado antes de ensamblar este producto.
2. Extraiga todo el hardware de la caja y ordene por tipo.
3. Verifique que todo el hardware y las piezas están presentes ANTES de ensamblar.
4. Para evitar daños, ensamble el producto sobre una superficie resistente, nivelada y con protección.
5. Espere hasta que todos los pasos se hayan completado antes de apretar completamente los tornillos y accesorios.
6. Asegúrese de que todos los tornillos y accesorios estén bien apretados antes de usar la unidad.
7. Para mover el producto debe levantarlo. NO lo arrastre, si lo arrastra puede causar volcamiento.
8. **Este producto se vende con un kit de accesorios para ser fijado en la pared. Debe instalar este kit para evitar accidentes o daños. Cuando se instala correctamente, esta restricción puede proporcionar protección contra la inclinación inesperada de la unidad debido a temblores pequeños, golpes o al treparse. La restricción es solo un elemento disuasivo y no es un sustituto de la supervisión adecuada de un adulto. El uso de restricciones de vuelco solo puede reducir, pero no eliminar, el riesgo de volcarse.**

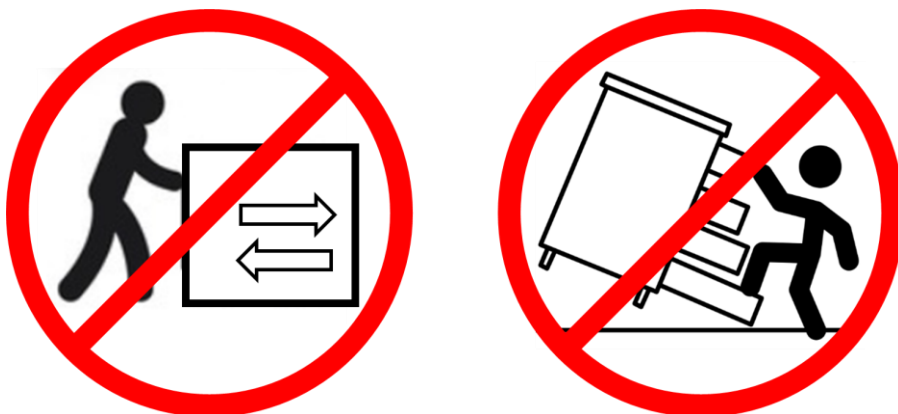

General Dimensions / Dimensiones Generales

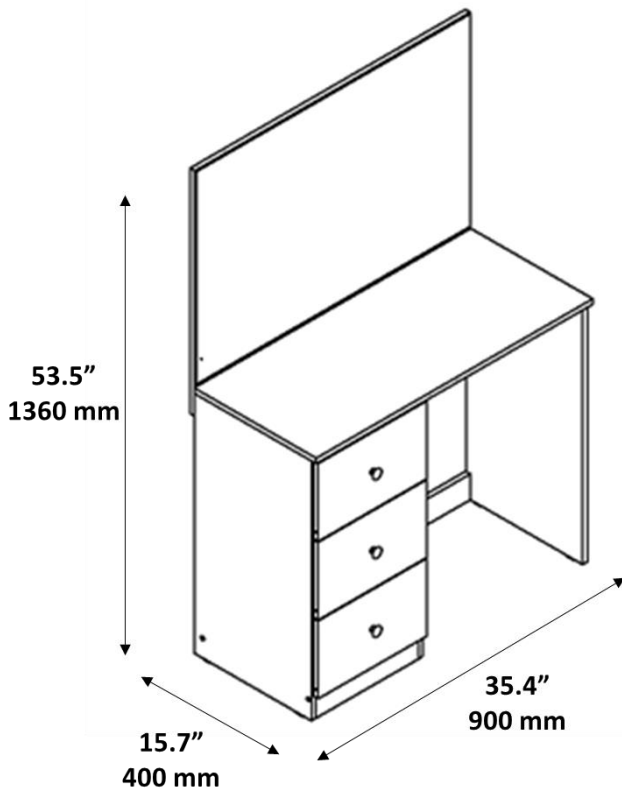

Maximum weight supported Peso máximo soportado

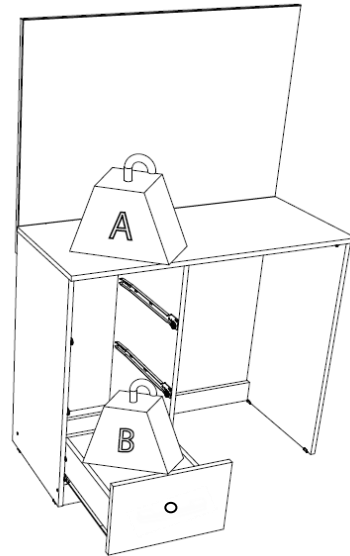

	LBS	KG
A	44	20
B	6.6	3

Note: weight must be evenly distributed.
Nota: el peso debe estar distribuido uniformemente.

You will need / usted necesitará:

Tools not included / herramientas no incluidas

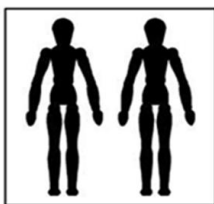

2 people
2 personas

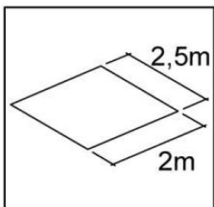

Recommended space for assembly
Espacio recomendado para el armado

Note: Place a carpet or blanket in the assembly area to avoid damage to the parts during the process.
Nota: Colocar una alfombra o manta en el area de armado para evitar daños en las piezas durante el proceso.

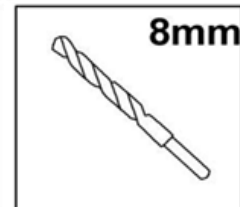
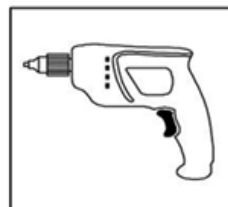
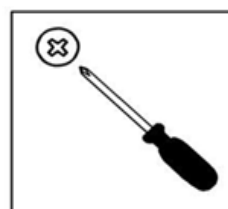

The drill will be used ONLY to fix the furniture to the wall.
El taladro será usado SOLO para fijar el mueble a la pared.





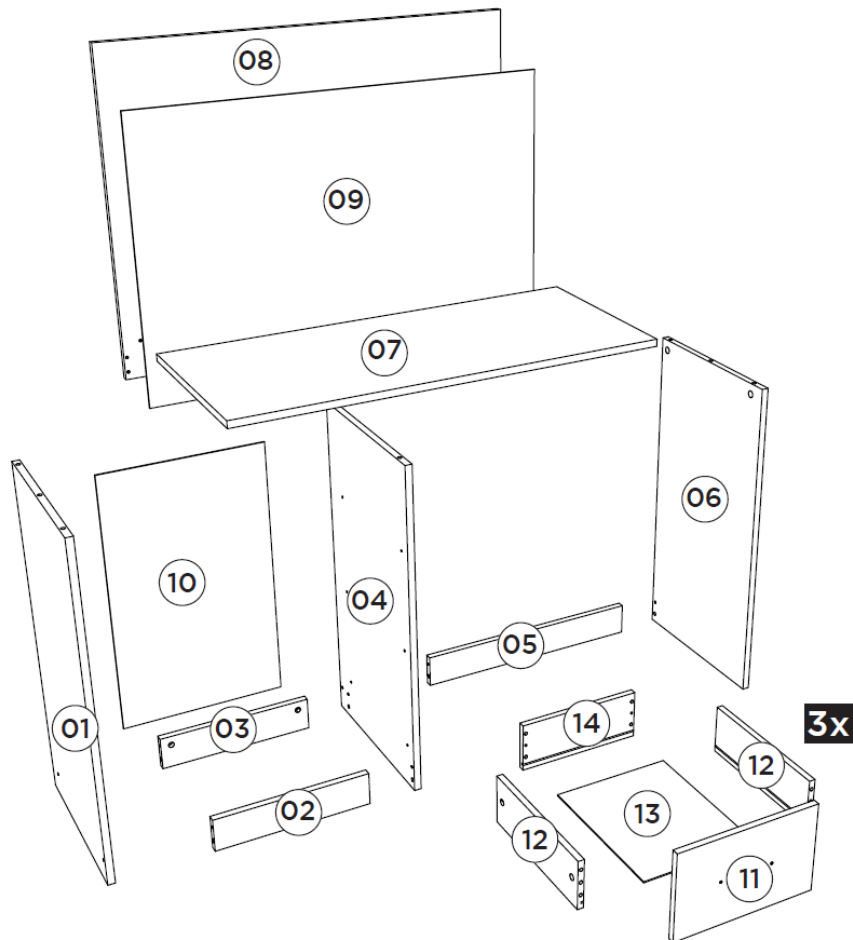





PARTS IDENTIFICATION / IDENTIFICACION DE PARTES





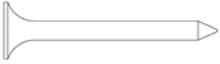
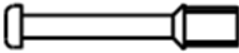

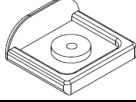

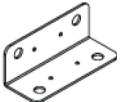

Nº	DESCRIPTION - DESCRIPCIÓN	QTY.
1	Left side / Lateral izquierdo	1
2	Front footer / Zócalo frontal	1
3	Rear footer / Zócalo trasero	1
4	Division / División	1
5	Large footer / Zócalo grande	1
6	Right side / Lateral derecho	1
7	Top base / Base superior	1
8	Mirror panel / Fondo de espejo	1
9	Mirror / Espejo	1
10	Backboard / Fondo	1
11	Front of drawer / Frente del cajón	3
12	Side of drawer / Lateral de cajón	6
13	Bottom of drawer / Fondo de cajón	3
14	Rear of drawer / Trasero de cajón	3



IDENTIFICATION OF ACCESSORIES / IDENTIFICACION DE ACCESORIOS

Note: the separation of the accessories before starting the assembly will facilitate it.
Nota: la separación de los accesorios antes de empezar el armado facilitará el mismo.

CODE		DESCRIPTION	QTY
A		Flat head screw / Tornillo cabeza plana (4,5 x 50 mm)	6
B		Flat head screw / Tornillo cabeza plana (3,5 x 40 mm)	10
C		Flanged head screw / Tornillo cabeza flangeada (3,5 x 25 mm)	3
D		Pan head screw / Tornillo cabeza redondeada (3,5 x 14 mm)	8
E		Flat head screw / Tornillo cabeza plana (3,5 x 12 mm)	30
F		Wooden dowel / Pin	36
G		Ringed Nail / Clavo anillado	6
H		Nail / Clavo	14
I		Simple minifix screw / Tornillo minifix simple	16
J		Drum lock / Tambor minifix	16
K		Cylindrical nut / Tuerca cilíndrica	6
L		L shoe / Zapata	6
M		Glue / Pegamento	2
N		Angle / Ángulo	2

O1		Metallic left slide / Corredera lateral izquierda	3
O2		Metallic right slide / Corredera lateral derecha.	3
O3		Left drawer slide / Corredera cajón izquierda.	3
O4		Right drawer slide / Corredera cajón derecha	3
P		Knob / Tirador	3
Q		Adhesive Bore patch / Tapón adhesive 17 mm	8
R		Adhesive Bore patch / Tapón adhesive 10 mm	8
S		Flat head screw / Tornillo cabeza plana (3 x 30 mm)	4
T		Wall bracket / Soporte pared	2
U		Strap / Correa	1



ATTENTION

To facilitate the assembly process, separate and organize all boards before you start.



Para facilitar el armado, separa y organiza todas las tablas antes de empezar.



PRE-ASSEMBLY / PRE- ARMADO

1. Fix **simple minifix screw** (I) and **wooden dowel** (F) to **top base** (7).
Fijar **tornillo minifix simple** (I) y **pin** (F) a **base superior** (7).

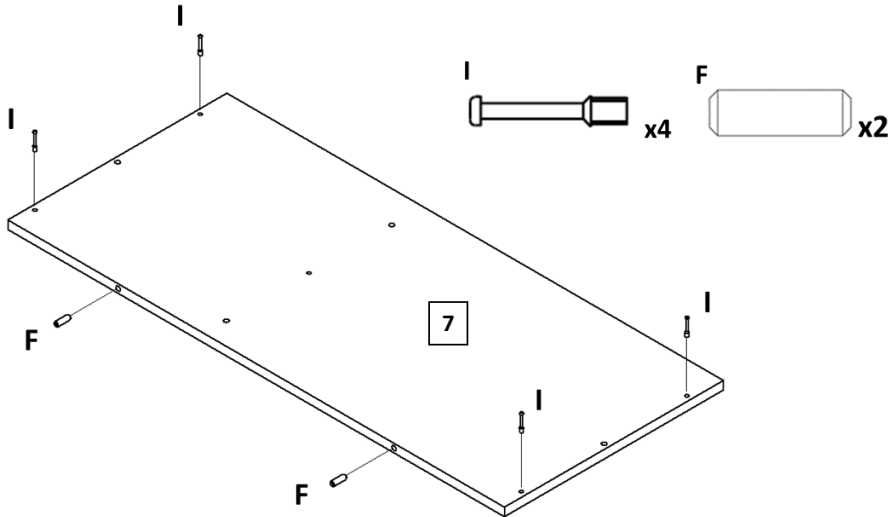

2. Fix **wooden dowel** (F) and **metallic left slide** (O1) to **left side** (1).
Fijar **pin** (F) y **corredera lateral izquierda** (O1) a **lateral izquierdo** (1).

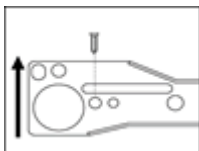
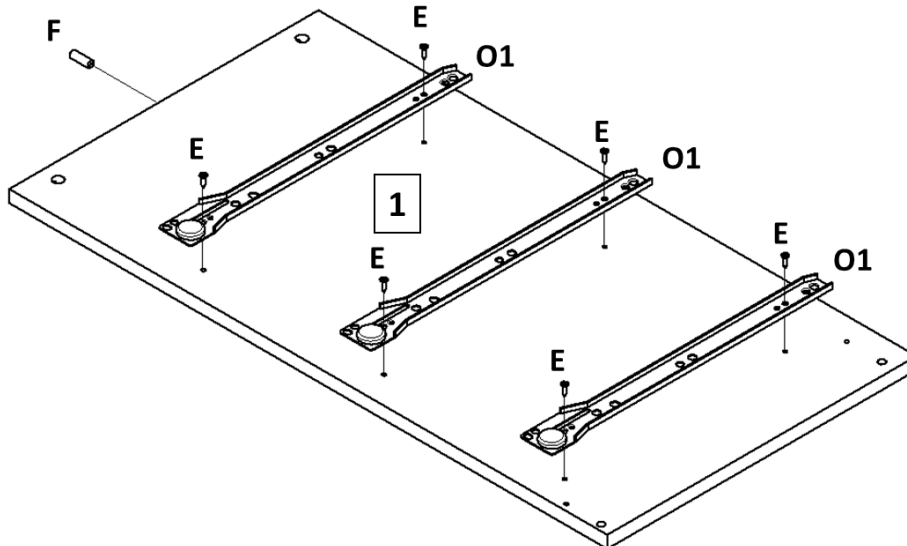

Note: the two upper holes have to be facing up.
Nota: los dos agujeros superiores deben estar hacia arriba.

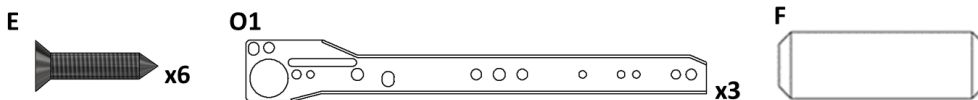

Note: add glue in the holes before placing the wooden dowel.
Nota: agregue el pegamento en los agujeros antes de colocar el pin.

3. Fix **wooden dowel** (F) and **metallic right slide** (O2) to **division** (4).
 Fijar **pin** (F) y **corredera lateral derecha** (O2) a **división** (4).

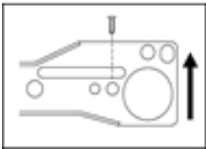
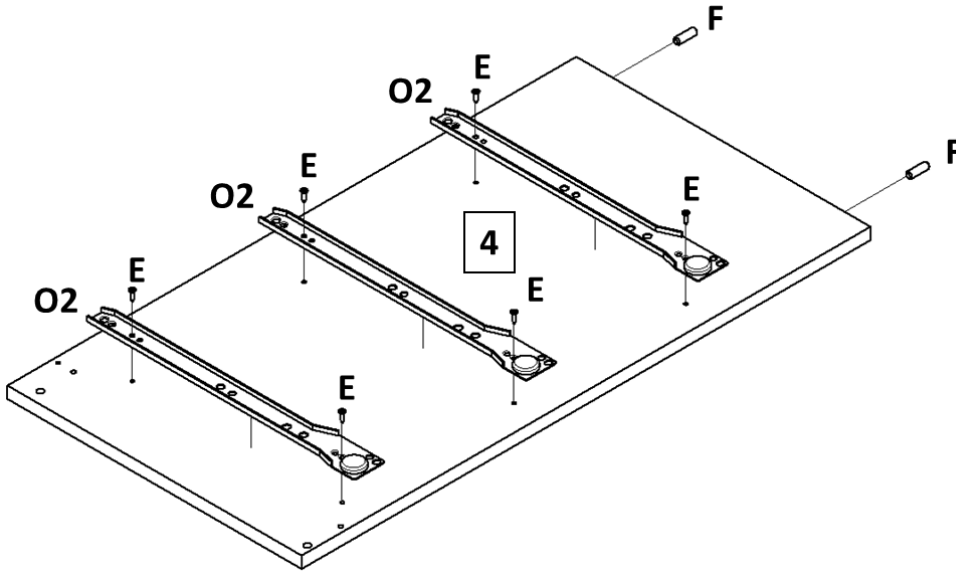

Note: the two upper holes have to be facing up.
Nota: los dos agujeros superiores deben estar hacia arriba.

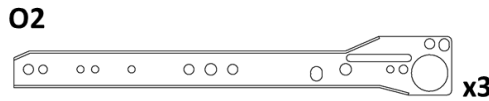
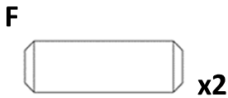

Note: add glue in the holes before placing the wooden dowel.
Nota: agregue el pegamento en los agujeros antes de colocar el pin.

4. Fix **wooden dowel** (F) to **right side** (6).
 Fijar **pin** (F) a **lateral derecho** (6).

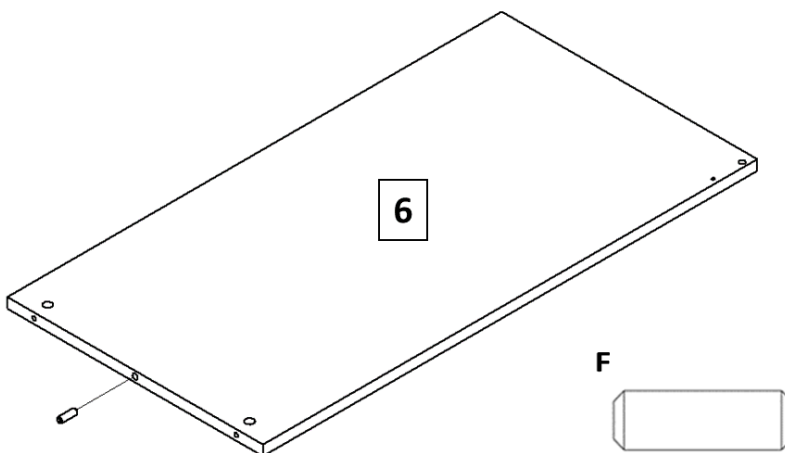

Note: add glue in the holes before placing the wooden dowel.
Nota: agregue el pegamento en los agujeros antes de colocar el pin.

5. Fix **wooden dowel** (F) to **side of drawer** (12) x6.
 Fijar **pin** (F) a **lateral de cajón** (12) x6.

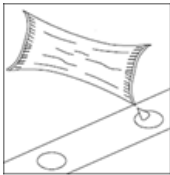
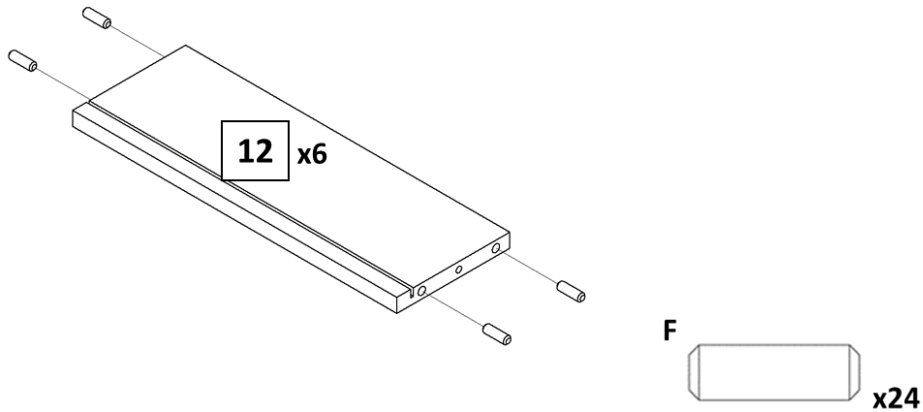

Note: add glue in the holes before placing the wooden dowel.
Nota: agregue el pegamento en los agujeros antes de colocar el pin.

6. Fix **simple minifix screw** (I) to **rear of drawer** (14) x3.
 Fijar **tornillo minifix simple** (I) a **posterior de cajón** (14) x3.

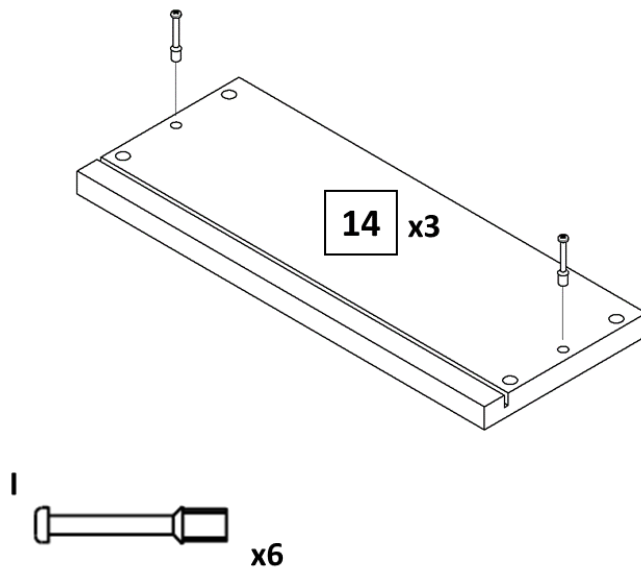

7. Fix **simple minifix screw** (I) and **Knob** (P) to **front of drawer** (11) x3.
 Fijar **tornillo minifix simple** (I) y **tirador** (P) a **frontal de cajón** (11) x3.

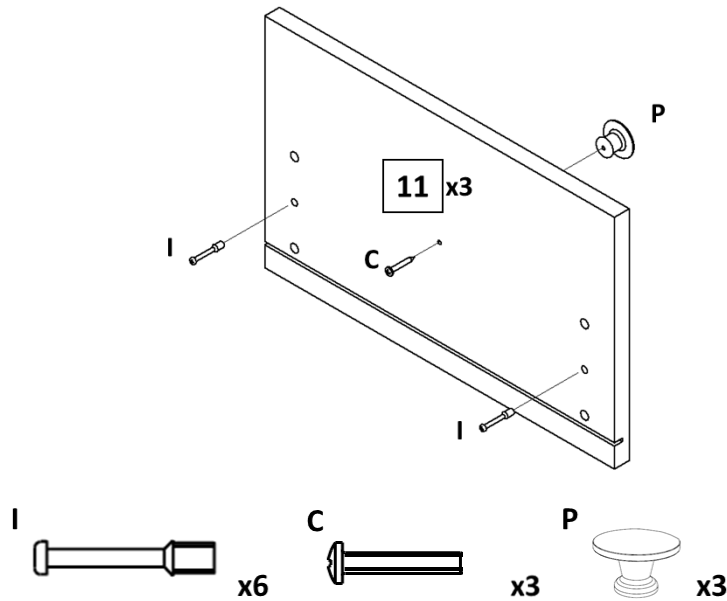

8. Fix **wooden dowel** (F) and **cylindrical nut** (K) to **front footer** (2), **rear footer** (3) and **large footer** (5).
 Fijar **pin** (F) y **tuerca cilíndrica** (K) a **zócalo frontal** (5), **zócalo trasero** (5) y **zócalo grande** (5).

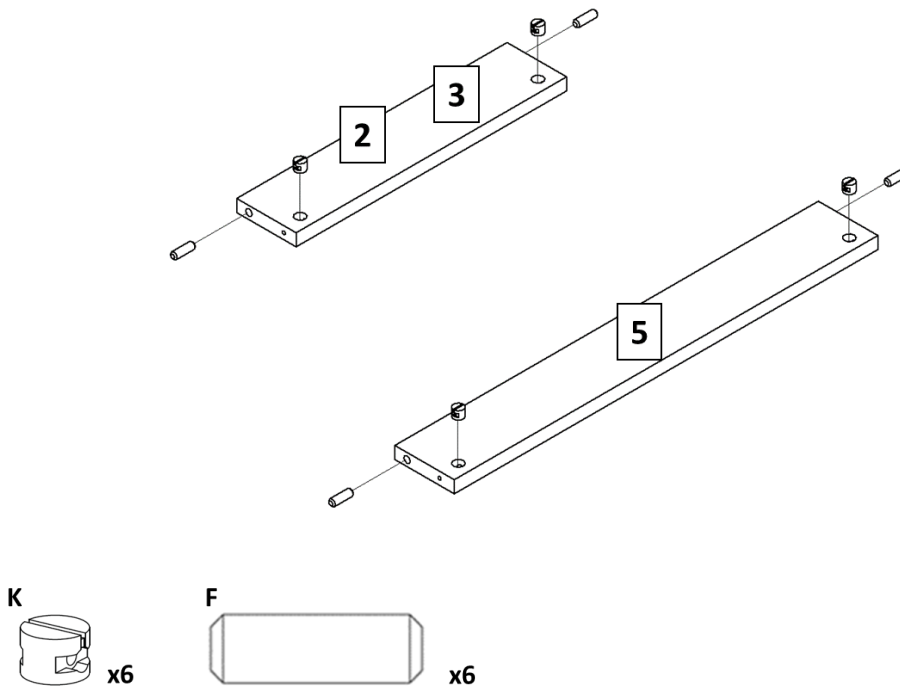

Note: add glue in the holes before placing the wooden dowel.
Nota: agregue el pegamento en los agujeros antes de colocar el pin.

ASSEMBLY / ARMADO

9. Fix **front footer** (2) and **rear footer** (3) to **left side** (1) and **division** (4)
 Fijar **zócalo frontal** (2) y **zócalo trasero** (3) a **lateral izquierdo** (1) y **división** (4).

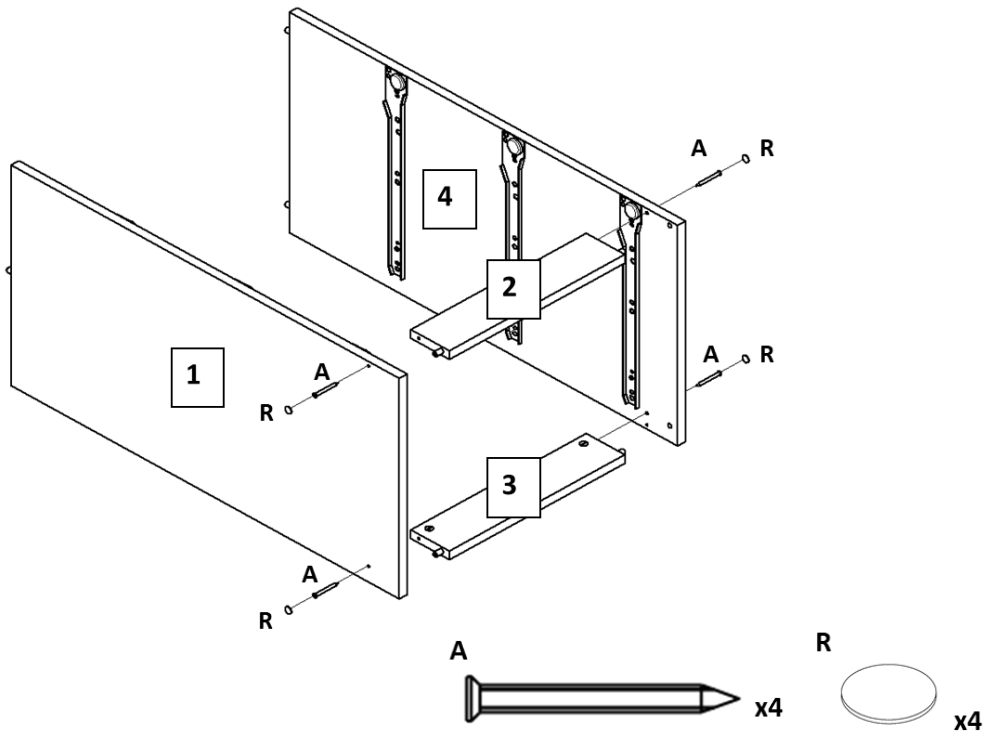

10. Fix **large footer** (5) and **right side** (6) to **previous assembly**.
 Fijar **zócalo grande** (5) y **lateral derecho** (6) a **ensamble previo**.

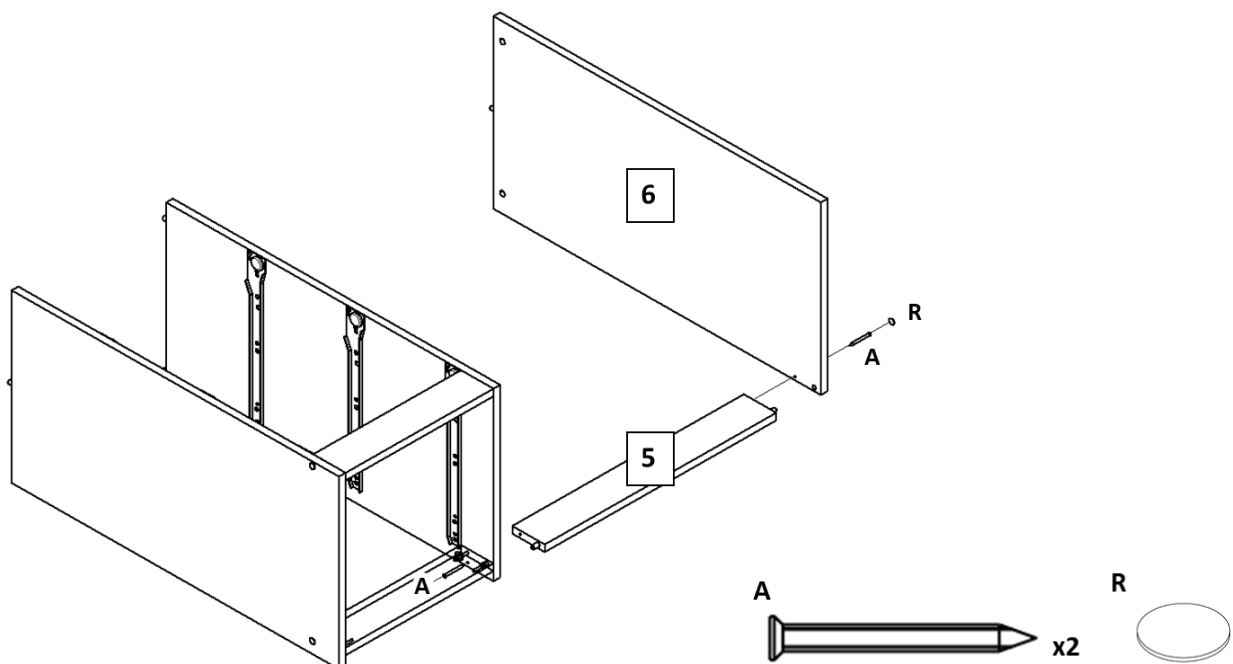

11. Fix **top base** (7) to previous assembly
 Fijar **top base** (7) ensamble previo

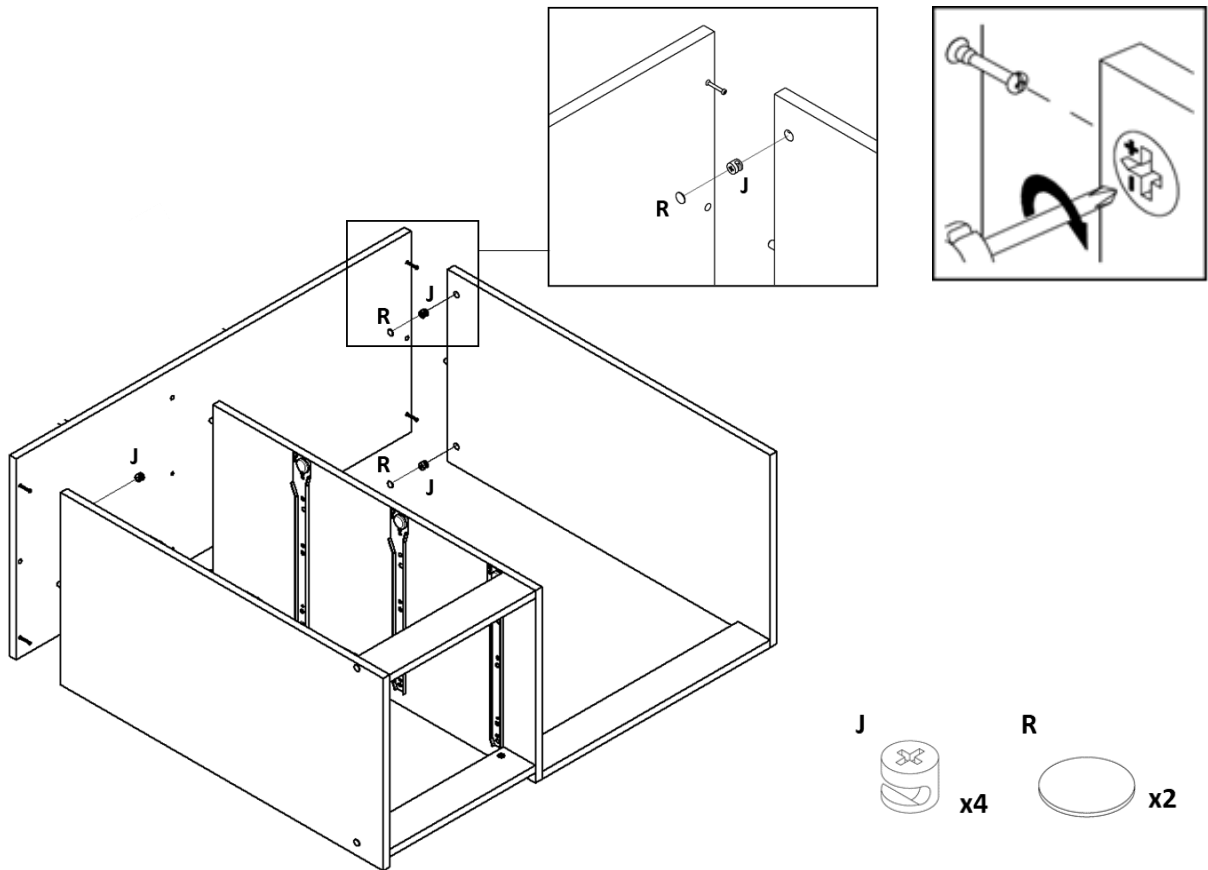

12. Fix **L shoe** (L) to previous assemble.
 Fijar **zapata** (L) a ensamble previo.

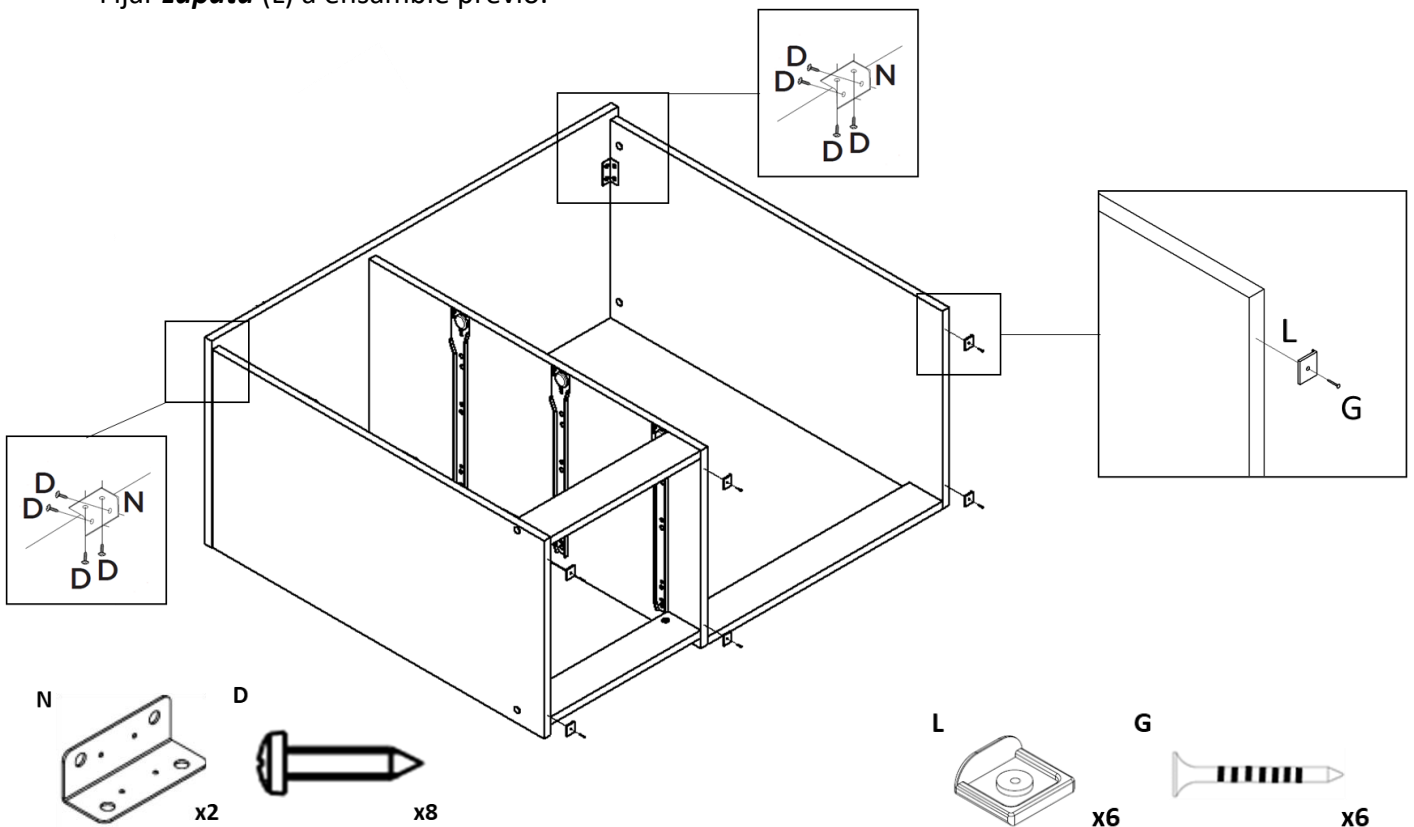

Need some Help? Call +1 281-809-4043 or email contact@boahaus.com
 ¿Necesitas ayuda? Llama +1 281-809-4043 o envía un email contact@boahaus.com

13. Incorporate furniture and fix **mirror** (08) and **backboard** (10).
 Incorpore el mueble y fije el **espejo** (08) **fondo trasero** (10).

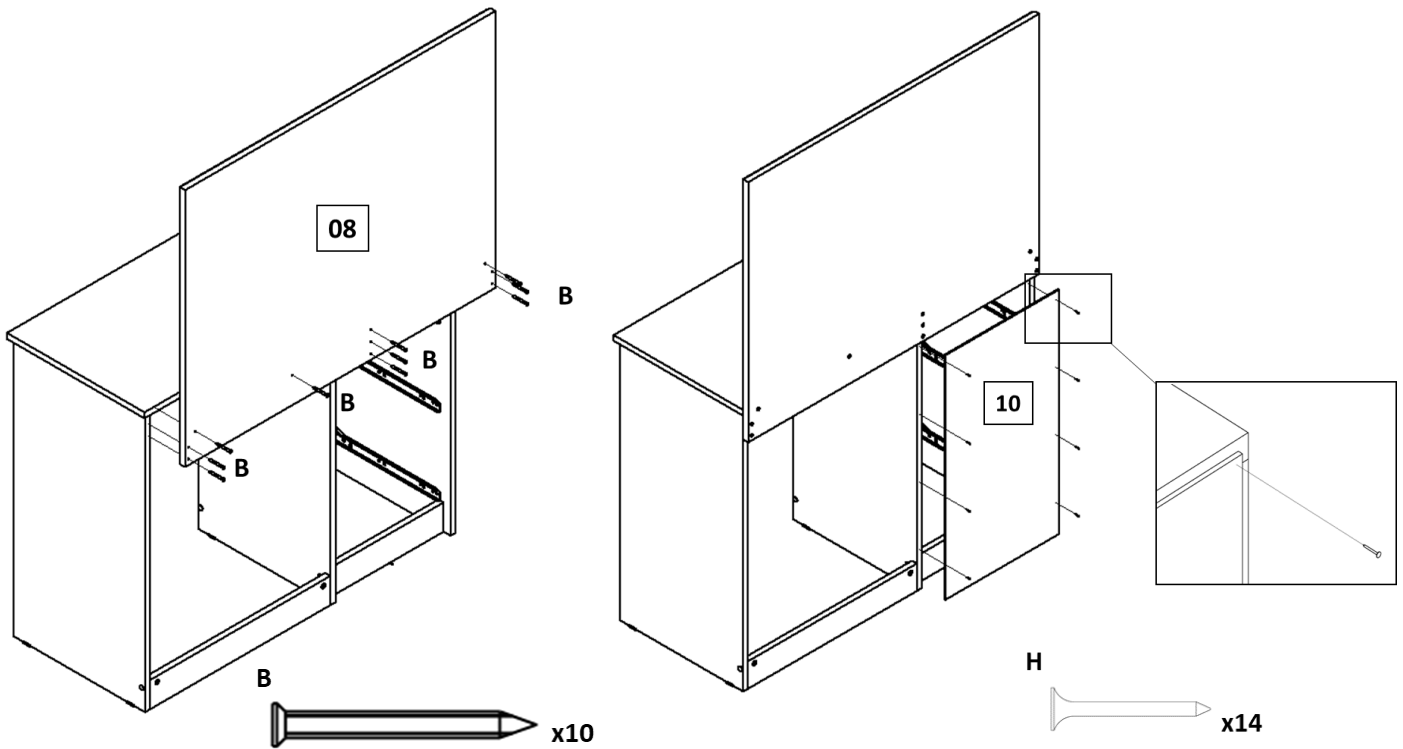

14. Assemble drawer x3.
 Ensamblar cajón x3.

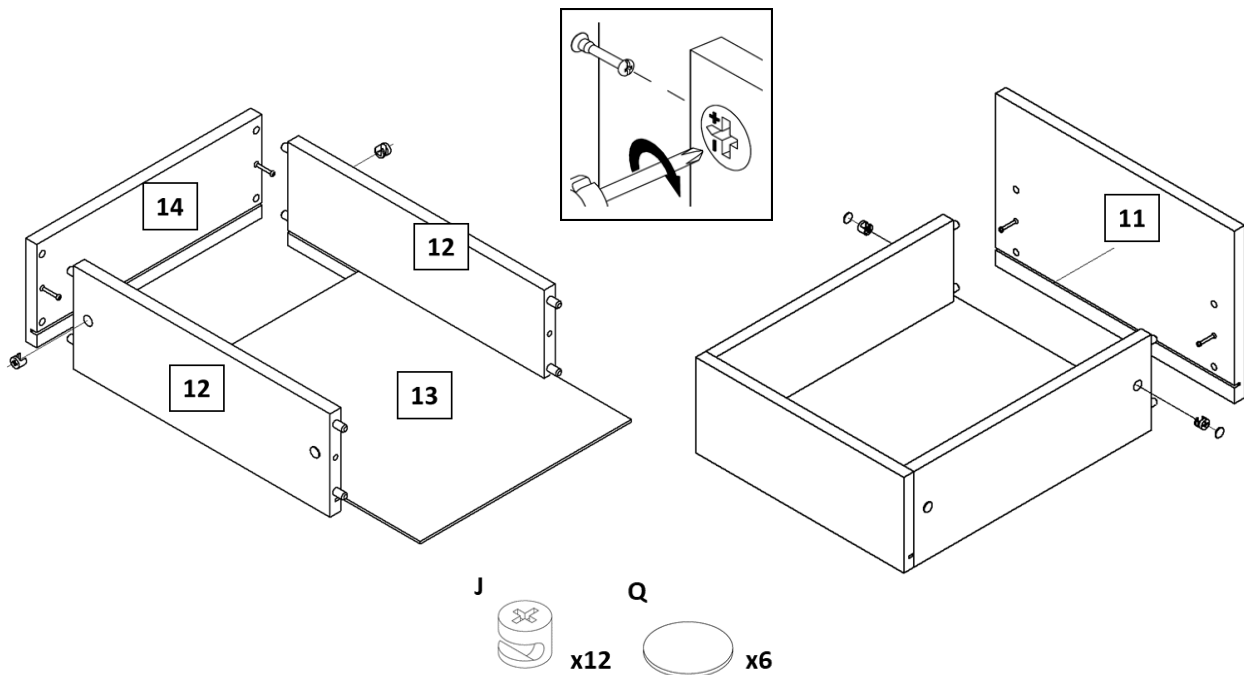

Note: add glue in the holes before placing the front of drawer
Nota: agregue el pegamento en los agujeros antes de colocar el frontal del cajón

Need some Help? Call +1 281-809-4043 or email contact@boahaus.com
 ¿Necesitas ayuda? Llama +1 281-809-4043 o envía un email contact@boahaus.com

15. Fix **left drawer slide** (O3) and **right drawer slide** (O4) to drawer x 3.

Fijar **corredera de cajón izquierdo** (O3) y **corredera de cajón derecho** (O4) a cajón x3.

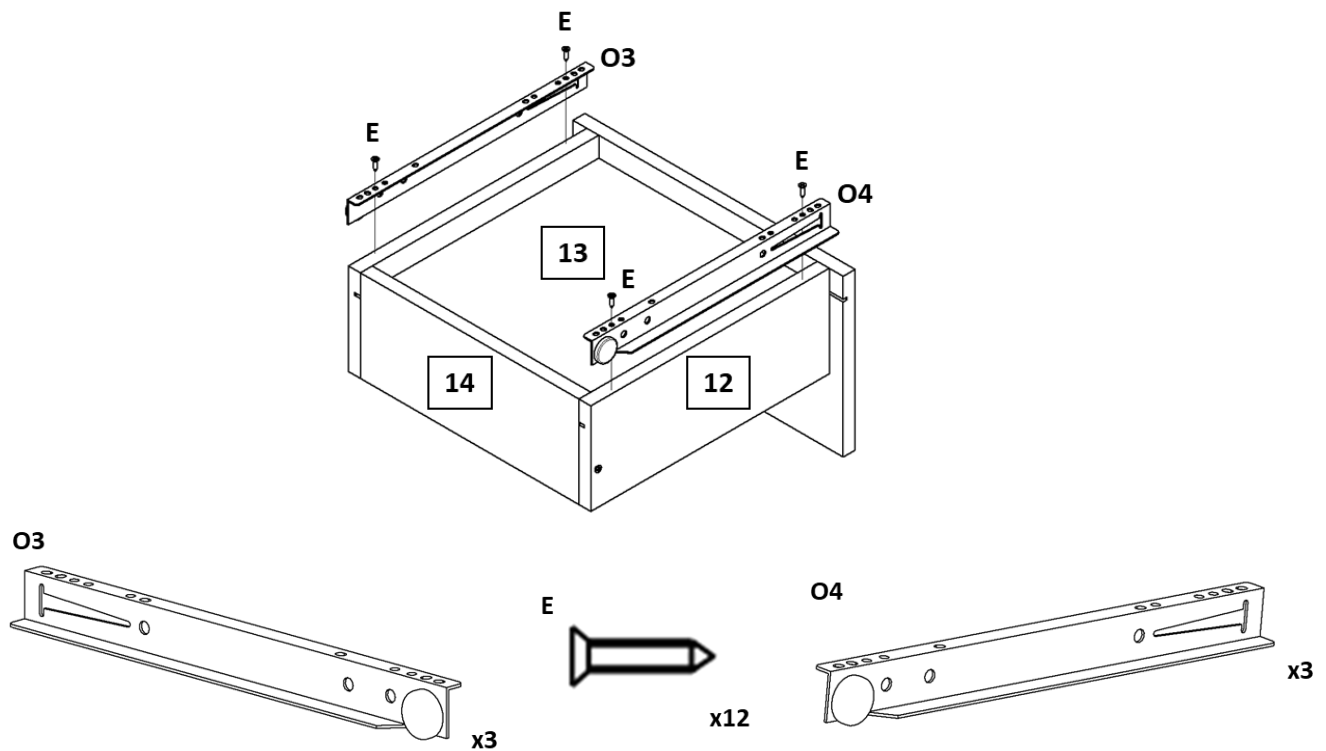

Note: the missing holes must be made with the screwdriver and the corresponding screw.
Nota: los agujeros faltantes deben hacerse con el destornillador y el tornillo correspondiente.

16. Place drawers on the furniture.

Colocar las gavetas en el mueble.

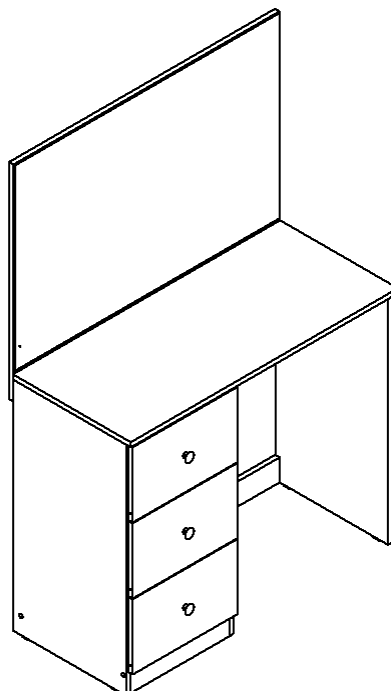

17. Fix furniture to the wall.
Fijar el mueble a la pared.

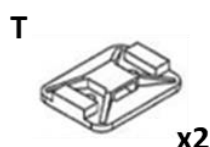
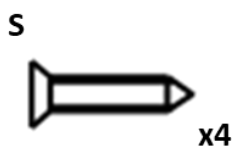
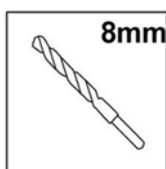
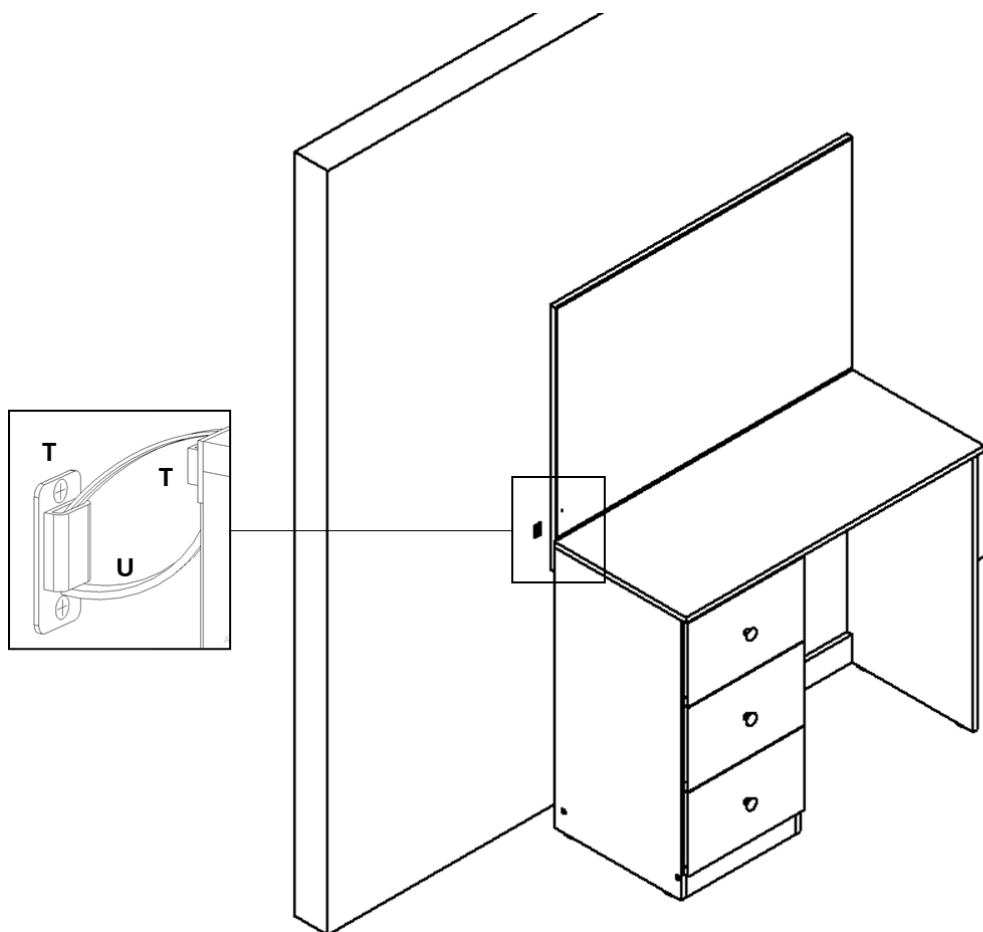

WARNING.

For safety reasons it is recommended to fix the furniture to the wall to avoid overturning of it, if this happens it can cause serious or fatal injuries.

ATENCIÓN.

Por medidas de seguridad se recomienda fijar el mueble a la pared para evitar volcamiento de este, si esto llegase a ocurrir puede causar lesiones graves o fatales.

IMPORTANT INFORMATION, PLEASE READ CAREFULLY AND FOLLOW THE INSTRUCTIONS

1. Locate a wall stud behind your furniture. Position a bracket on the stud approximately 1" below the top of the furniture. Mark & drill pilot hole into the center of the stud with a 3/30" drill bit. Attach a bracket (T) to the stud with the long screws (S).

2. On the back of the furniture a bracket will need to be attached to the furniture frame at the top. To do this, temporarily move the furniture into its final position & mark the location of the wall bracket on the furniture frame. Move the furniture away from the wall & drill holes for screws with a 3/30" drill bit.

Attach the bracket (T) to the furniture with the short screws (S).

3. Move the furniture into its final position, taking care to line up the wall bracket with the furniture bracket.

Thread a strap (U) through the bracket as shown in the illustration.

Tighten strap until snug. Do not overtighten.

IMPORTANT: Check to be sure the wall bracket is firmly screwed into wall stud, the furniture bracket is firmly attached to the frame, and the strap is snug.

INFORMACIÓN IMPORTANTE, POR FAVOR LEA CUIDADOSAMENTE Y SIGUE EL INSTRUCCIONES

1. Localice un poste de pared detrás de su mueble. Coloque un soporte en el perno aproximadamente 1 " debajo de la parte superior del mueble. Marcar y perforar el agujero piloto en el centro del perno con una broca de 3/30 ".

Fije un soporte (T) al perno con el tornillo (S).

2. En la parte posterior del mueble un soporte tendrá que estar unido al marco del mueble en la parte superior. Para hacer esto, mover temporalmente el mueble a su posición final y marca la ubicación del soporte de pared en el mueble. Mueva el mueble lejos de la pared y taladre con una broca 3/30 ".

Fije el soporte (T) al mueble con los tornillos cortos (S).

3. Mueva el mueble a su posición final, cuidando de alinear el soporte de la pared con el soporte de muebles.

Pase una correa (U) a través del soporte como se muestra en la ilustración.

Apriete la correa hasta que quede ajustada. No apriete demasiado.

IMPORTANTE: Verifique para asegurarse de que el soporte de pared esté firmemente atornillado a la pared, el soporte de muebles está firmemente unido al marco, y la correa está ajustada.

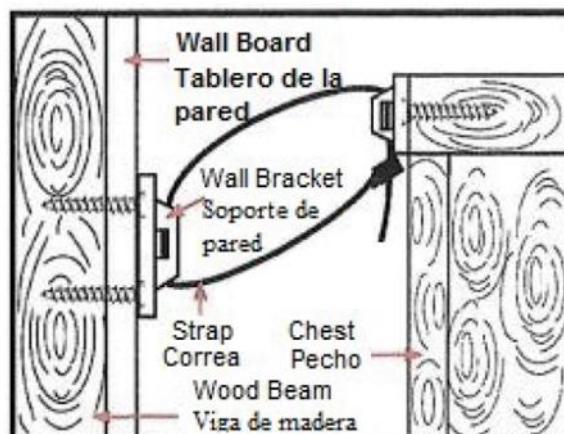

1638 Boahaus Dressing Table with Mirror Warranty

6-Months Limited Warranty

1. Boahaus, LLC provides limited warranty coverage to the original purchaser of this product for a period of six months from the date of purchase against defects in materials or workmanship of Boahaus furniture components. As used in this Warranty, "defect" means imperfections in components which substantially impair the utility of the product. This Warranty gives you specific legal rights, and you may also have other rights which vary from state to state.
2. There is no warranty coverage for defects or conditions that result from the failure to follow product assembly instructions, information or warnings, misuse or abuse, intentional damage, fire, flood, alteration or modification of the product, or use of the product in a manner inconsistent with its intended use, nor any condition resulting from incorrect or inadequate maintenance, cleaning, or care. There is also no warranty coverage for rented products or any products purchased "used" or "as is", at a distress or going-out-of business sale, or from a liquidator.
3. As the exclusive remedy under this Warranty, Boahaus will (at its sole option) repair, replace or refund the value of any defective furniture component. Boahaus may require independent confirmation of the claimed defect and proof of purchase. Replacement parts will be warranted for only the remaining period of the original Warranty. BOAHAUS SHALL HAVE NO LIABILITY for ANY INCIDENTAL OR CONSEQUENTIAL DAMAGES OF ANY KIND and all such damages are EXCLUDED FROM THIS WARRANTY, such as loss of use, disassembly, transportation, labor or damage to property on or near the product. Some states do not allow the exclusion or limitation of incidental or consequential damages, so the above limitation or exclusion may not apply to you.
4. This Warranty applies only to warranted defects that first arise and are reported to Boahaus within the warranty coverage period. The Warranty cannot be transferred to subsequent owners or users of the product, and it shall be immediately void in the event the product is resold, transferred, leased or rented to any third party or person other than the original purchaser.
5. THERE ARE NO OTHER WARRANTIES APPLICABLE TO THIS PRODUCT. Under the laws of certain states, there may be no implied warranties from Boahaus and all implied warranties, INCLUDING ANY IMPLIED WARRANTY OF MERCHANTABILITY OR FITNESS FOR A PARTICULAR PURPOSE are disclaimed where allowed by law. TO THE EXTENT ANY IMPLIED WARRANTIES ARE APPLICABLE, ANY IMPLIED WARRANTIES, INCLUDING ANY IMPLIED WARRANTY OF MERCHANTABILITY OR FITNESS FOR A PARTICULAR PURPOSE, ARE LIMITED IN DURATION TO THE DURATION OF THIS EXPRESS WARRANTY or the minimum period allowed by law, whichever is shorter. Some states do not allow limitations on how long an implied Warranty lasts, so the above limitation may not apply to you.
6. For Warranty inquiries, questions about disposition or claims, please visit our website www.boahaus.com. You can also contact Boahaus at **+1 281-809-4043** or email at contact@boahaus.com. Boahaus may require Warranty claims to be submitted in writing to:

Boahaus LLC.
1250-1252
Ave. Franklin Delano Roosevelt,
San Juan, PR 00926.

Please include your sales receipt or other proof of purchase and a specific description of the product defect.

Garantía de Tocador con Espejo 1638 Boahaus**Garantía limitada de 6 meses**

1. Boahaus, LLC proporciona cobertura de garantía limitada al comprador original de este producto por un período de 6 meses a partir de la fecha de compra contra defectos en materiales o mano de obra de componentes de muebles de Boahaus. Como se especifica en esta Garantía, "defecto" significa imperfecciones en componentes que perjudican sustancialmente la utilidad del producto. Esta Garantía le otorga derechos legales específicos y también puede tener otros derechos que varían de un estado a otro.
2. No hay cobertura de garantía por defectos o condiciones que resulten del incumplimiento de las instrucciones del producto, o advertencias, uso indebido o abuso, daño intencional, incendio, inundación, alteración o modificación del producto o uso del producto de manera inconsistente con su uso previsto, o cualquier condición resultante de mantenimiento incorrecto o inadecuado, limpieza o cuidado. Tampoco hay cobertura de garantía para productos alquilados o cualquier producto comprado "usado" o "tal cual", en una venta de emergencia o de salida de la empresa, o de un liquidador.
3. Boahaus puede requerir una confirmación independiente del defecto reclamado y un comprobante de compra. Las piezas de repuesto estarán garantizadas durante el período restante de la garantía original. BOAHAUS NO TENDRÁ NINGUNA RESPONSABILIDAD POR CUALQUIER DAÑO INCIDENTAL y todos estos daños ESTÁN EXCLUIDOS DE ESTA GARANTÍA, tales como pérdida de uso, desmontaje, transporte, mano de obra o daños a la propiedad en o cerca del producto. Algunos estados no permiten la exclusión o limitación de daños incidentales o consecuentes, por lo que la limitación o exclusión anterior puede no aplicarse a usted.
4. Esta Garantía se aplica únicamente a los defectos garantizados que surgen y se informan a Boahaus dentro del período de cobertura de la garantía. La garantía no puede ser transferida a los propietarios o usuarios posteriores del producto, y será inmediatamente nula en caso de que el producto sea revendido, transferido, arrendado o alquilado a cualquier tercero o persona que no sea el comprador original.
5. NO HAY OTRAS GARANTÍAS APLICABLES A ESTE PRODUCTO. Bajo las leyes de ciertos estados, no puede haber garantías implícitas de Boahaus y todas las garantías implícitas, INCLUYENDO CUALQUIER GARANTÍA IMPLÍCITA DE COMERCIABILIDAD O ADECUACIÓN PARA UN PROPÓSITO EN PARTICULAR, están exoneradas cuando permitido por la ley. TODAS LAS GARANTÍAS IMPLÍCITAS SON APLICABLES, LAS GARANTÍAS IMPLÍCITAS, INCLUIDAS CUALQUIER GARANTÍA IMPLÍCITA DE COMERCIABILIDAD O ADECUACIÓN PARA UN PROPÓSITO PARTICULAR, ESTÁN LIMITADAS EN DURACIÓN A LA DURACIÓN DE ESTA GARANTÍA EXPRESA o el período mínimo permitido por la ley, cualquiera que sea más corto. Algunos estados no permiten limitaciones sobre la duración de una garantía implícita, por lo que es posible que la limitación anterior no se aplique a usted.
6. Para consultas sobre la garantía, preguntas sobre la disposición o reclamaciones, visite nuestro sitio web www.boahaus.com. También puede ponerse en contacto con Boahaus en **+1 281-809-4043** o por correo electrónico en contact@boahaus.com. Boahaus puede requerir que los reclamos de garantía sean presentados por escrito a:

Boahaus LLC.
1250-1252
Ave. Franklin Delano Roosevelt,
San Juan, PR 00926.

Incluya su recibo de compra u otra prueba de compra y una descripción específica del defecto del producto.

Thank you for purchasing our company's DIY makeup mirror fill light products, this product supports DIY own home mirror, instantly make their own mirror into a modern fashion makeup with LED Fill mirror.

Product Features:

1. The standard USB power supply, safety generic.
2. PC soft mask, don't stab the eye
3. Concealable wiring: simple and neat
4. All transparent lines, beautiful and stylish
5. Luminance color temperature adjustable

Product parameters:

Product Name: Vanity Mirror Lights
Bulb size: 45 MM
Power supply: Standard USB 5V 2A or above
LED color temperature: 3200K&6500K
Lamp power: 10W
Material: ABS+ PC

Wisdom in design: It is easy and convenient to use sticker for mirror glass, wood, plastic and metal surface. According to their own unique design DIY installed in the dresser fill light and decoration.

Rest assured dressing: USB low voltage power supply, safe! Multilevel luminance adjustable, suitable for different dressing needs.



Use the installation details see inside pages

Vanity Mirror Lights

Instructions

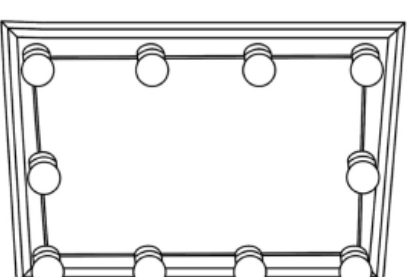

USB Power Beauty forever Color temperature brightness

Meet Different Self

DIY Mirror Front Light

Need some Help? Call +1 (787) 688-1254 or email contact@boahaus.com

¿Necesitas ayuda? Llama +1 (787) 688-1254 o envía un email contact@boahaus.com

Functional description

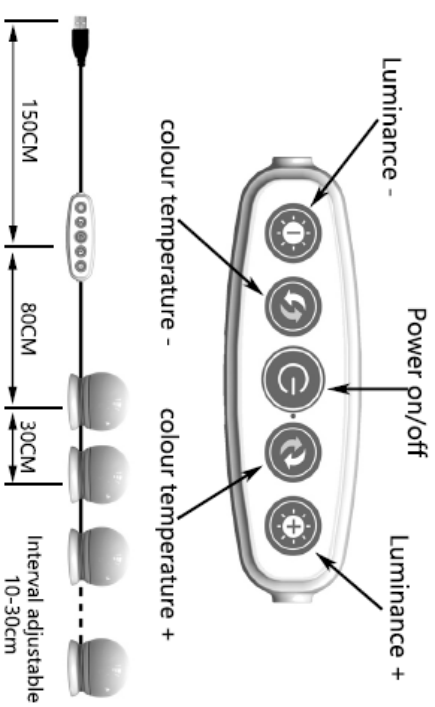

Precautions for use

1. It is recommended to choose 2A or above USB power adapter, mobile phone charger and other standard USB mobile power can be used.
 2. The product uses double-sided adhesive paste fixed, requiring installation of the bonding surface must be clean, dry, smooth, can not have rust and oil.
 3. The wire can be adjusted through the winding between the base slot, and the bulb spacing can be adjusted between 10-30cm.
- Reminded:** When the bulb is pasted, you must press the product for about 30 seconds, it takes 24 hours to achieve the best adhesive strength.

Meet Different Self

Wisdom in design, Rest assured, Enjoy life

Need some Help? Call +1 (787) 688-1254 or email contact@boahaus.com

¿Necesitas ayuda? Llama +1 (787) 688-1254 o envía un email contact@boahaus.com

Install reference diagram

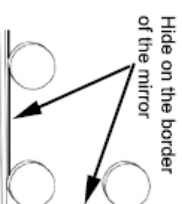
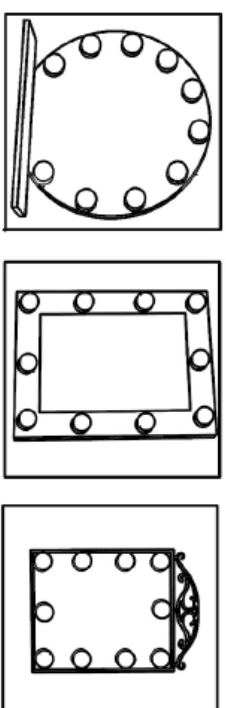

Hide on the border of the mirror



Length of winding adjustment line

Installation steps

1. Cosmetic mirror or be installed Surface treatment: should be sticky surface should be dry, clean, no rust, oxidation, grease, dust and other pollutants.
2. According to the design of the number of mirrors and bulbs each bulb installation location, note the lamp spacing of up to 30cm, the minimum spacing of about 10cm.
3. Remove the product to determine the power and control switch to place the seat is appropriate to determine the first light paste location (with the control switch to connect the first line)
4. The bottom of the product double-sided adhesive tape tear off the film, and then affixed to the first lamp position, forced down, so that double-sided adhesive paste better, Make the tape and the bonding surface get full contact.