

boahaus

ASSEMBLY INSTRUCTIONS

ATTENTION!!!

Any inquiry or replacement parts you need, contact us directly at:

contact@boahaus.com

Scan this QR Code to chat to Customer Support Team.



Or Call Us at +1 281-809-4043

boahaus

ASSEMBLY INSTRUCTIONS INSTRUCCIONES DE ARMADO

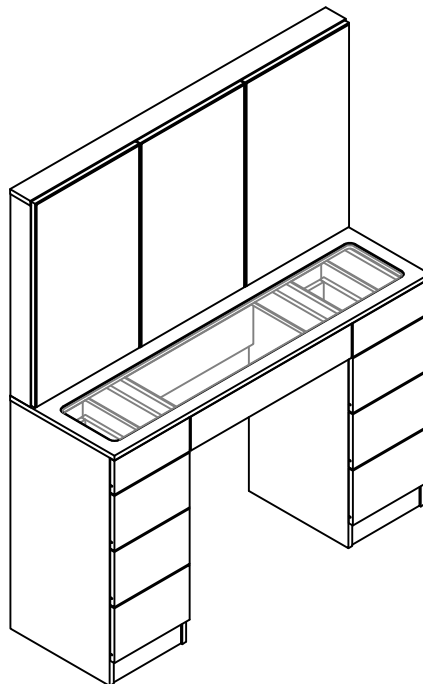

MODEL #: 1637

DRESSING TABLE WITH MIRROR
Tocador con Espejo

Aprox. product weight 105.02 lbs. / 47,71 Kg.

**Weight may vary +/- 5%.

Lot: See package

Production date: See package

Purchase date: _____

THIS INFORMATION BOOKLET CONTAINS IMPORTANT SAFETY INFORMATION. PLEASE READ AND KEEP FOR FUTURE REFERENCE.
ESTE FOLLETO CONTIENE INFORMACIÓN DE SEGURIDAD IMPORTANTE. POR FAVOR, LEA Y GUÁRDELO PARA REFERENCIA FUTURA.

Need some Help? Call +1 281-809-4043 or email contact@boahaus.com
¿Necesitas ayuda? Llama +1 281-809-4043 o envía un email contact@boahaus.com

Need some Help? Call +1 281-809-4043 or email contact@boahaus.com
¿Necesitas ayuda? Llama +1 281-809-4043 o envía un email contact@boahaus.com

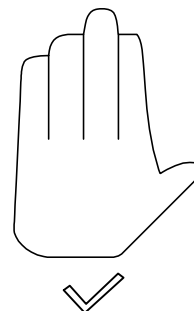
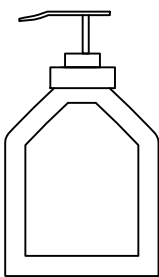
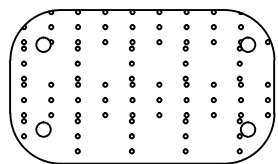

To Remove the printed number, apply a small amount of Glass Cleaner or Hand sanitizer and wipe with a paper towel.

Para eliminar el número impreso, aplique una pequeña cantidad de limpiacristales o desinfectante de manos y limpie con una toalla de papel.

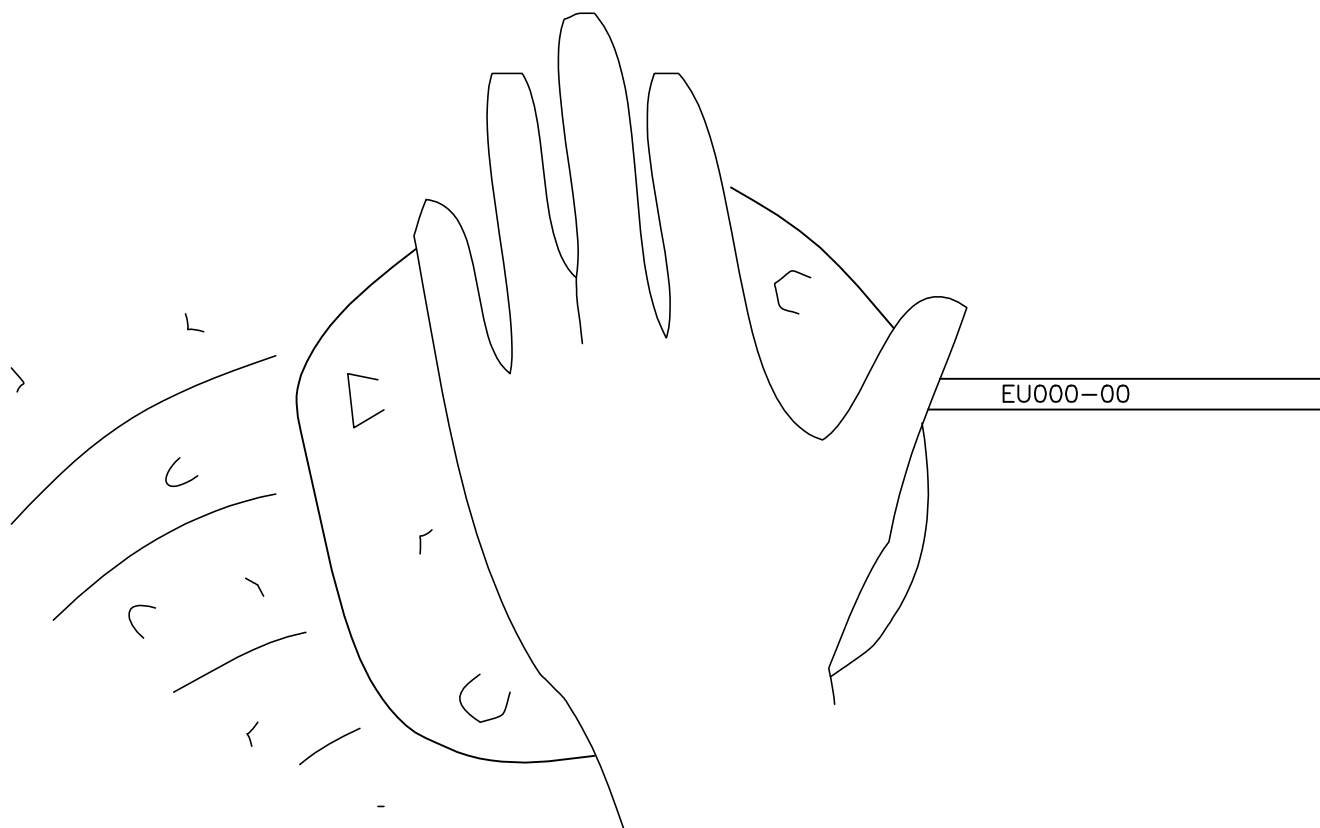

GENERAL SAFETY INFORMATION

1. Please read the Assembly Instructions prior to assembling this product.
2. Remove all the hardware from the box and sort by type.
3. Check to see that all the hardware and parts are present BEFORE assembling.
4. To avoid damage, assemble the product on a sturdy, level, and protective surface.
5. Please wait until all steps are completed before fully tightening bolts.
6. Make sure all bolts are tightly fastened before the unit is used.
7. To move the product, you must lift it. DO NOT drag it, if you drag it can cause overturning.
- 8. This product is sold with a hardware kit to be fixed on the wall. You must install this kit to prevent any accidents or damages. When properly installed, this restrain can provide protection against the unexpected tipping of the unit due to small tremors, bumps or climbing. The restrain is only a deterrent and is not a substitute for proper adult supervision. Use of tip-over restraints may only reduce, but not eliminate, the risk of tip-over**

INFORMACIÓN GENERAL DE SEGURIDAD

1. Lea las instrucciones de armado antes de ensamblar este producto.
2. Extraiga todo el hardware de la caja y ordene por tipo.
3. Verifique que todo el hardware y las piezas están presentes ANTES de ensamblar.
4. Para evitar daños, ensamble el producto sobre una superficie resistente, nivelada y con protección.
5. Espere hasta que todos los pasos se hayan completado antes de apretar completamente los tornillos y accesorios.
6. Asegúrese de que todos los tornillos y accesorios estén bien apretados antes de usar la unidad.
7. Para mover el producto debe levantarlo. NO lo arrastre, si lo arrastra puede causar volcamiento.
- 8. Este producto se vende con un kit de accesorios para ser fijado en la pared. Debe instalar este kit para evitar accidentes o daños. Cuando se instala correctamente, esta restricción puede proporcionar protección contra la inclinación inesperada de la unidad debido a temblores pequeños, golpes o al treparse. La restricción es solo un elemento disuasivo y no es un sustituto de la supervisión adecuada de un adulto. El uso de restricciones de vuelco solo puede reducir, pero no eliminar, el riesgo de volcarse.**

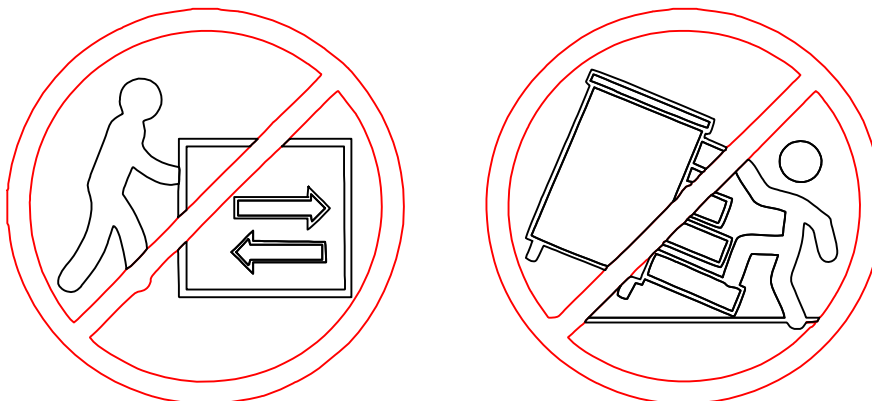

PARTS IDENTIFICATION / IDENTIFICACION DE PARTES

General Dimensions / Dimensiones Generales

Maximum weight supported /
Peso máximo soportado

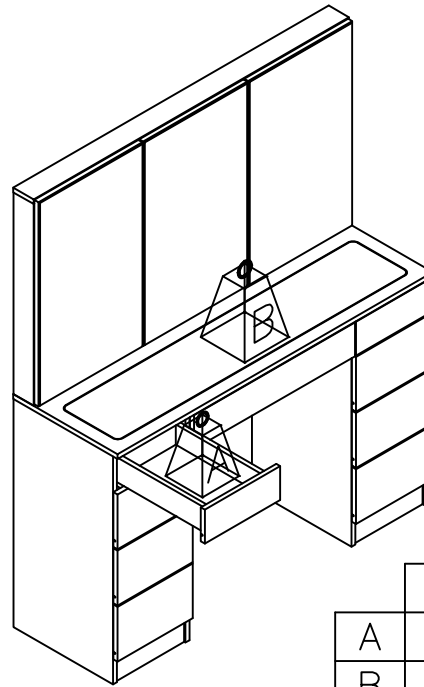
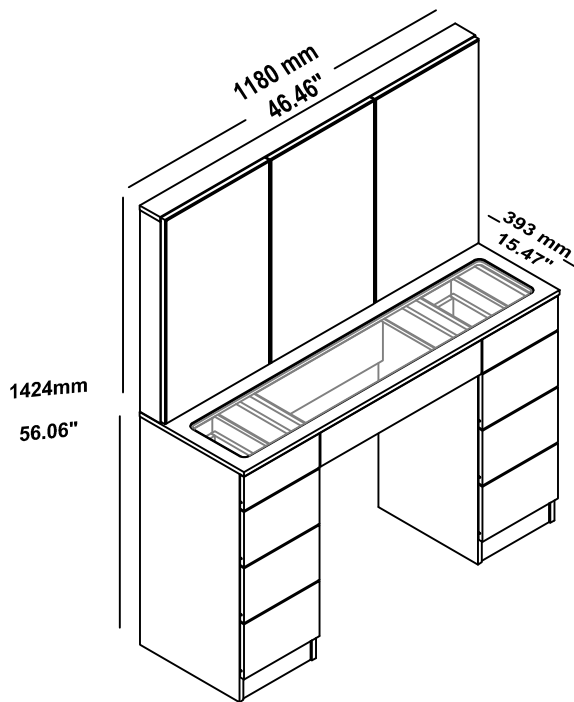

	Kg	lb
A	6	13.23lb
B	5	11.02lb

Weight in pounds. / Peso en libras.

Note: weight must be evenly distributed.

Nota: el peso debe estar distribuido uniformemente.

You will need / usted necesitará:

Tools not included / herramientas no incluidas

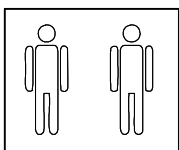

2 people
2 personas

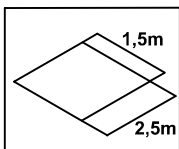

Recommended space for assemble
Espacio recomendado para el armado

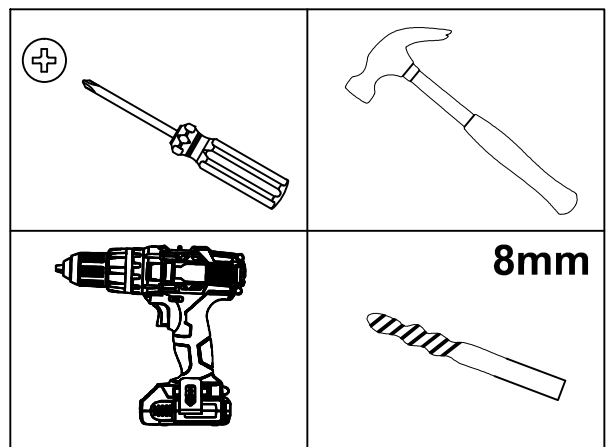

Note: Place a carpet or blanket in the assembly area to avoid damage to the parts during the process.

Nota: Colocar una alfombra o manta en el area de armado para evitar daños en las piezas durante el proceso.



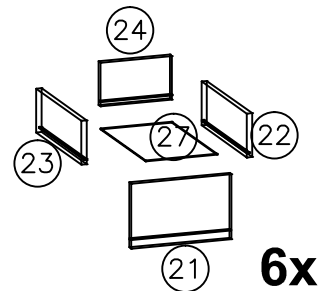
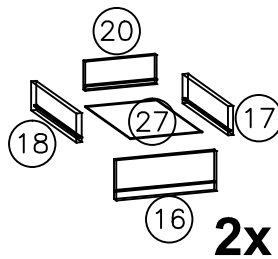
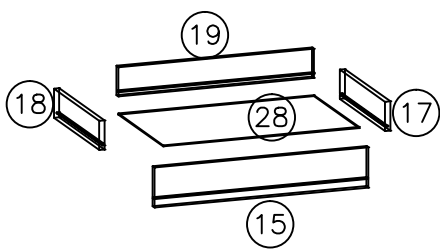
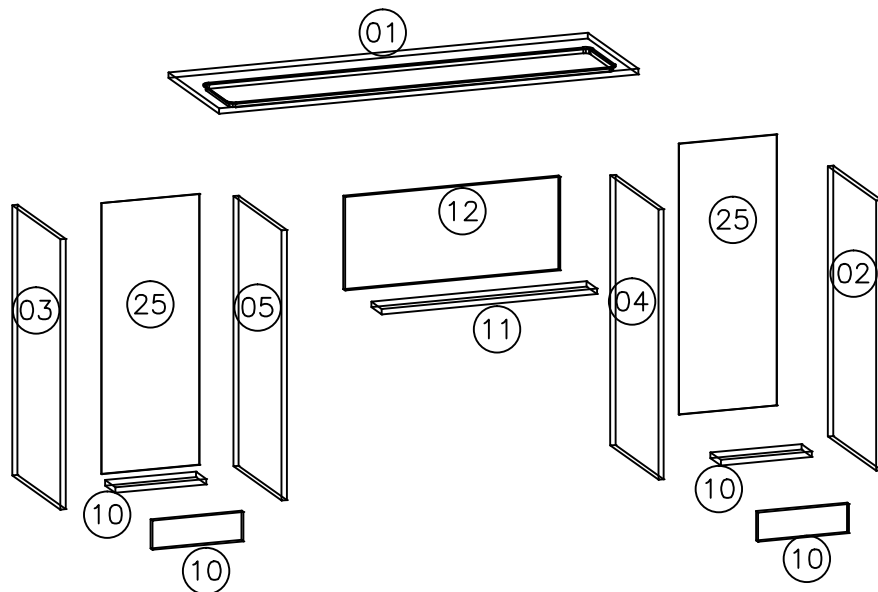
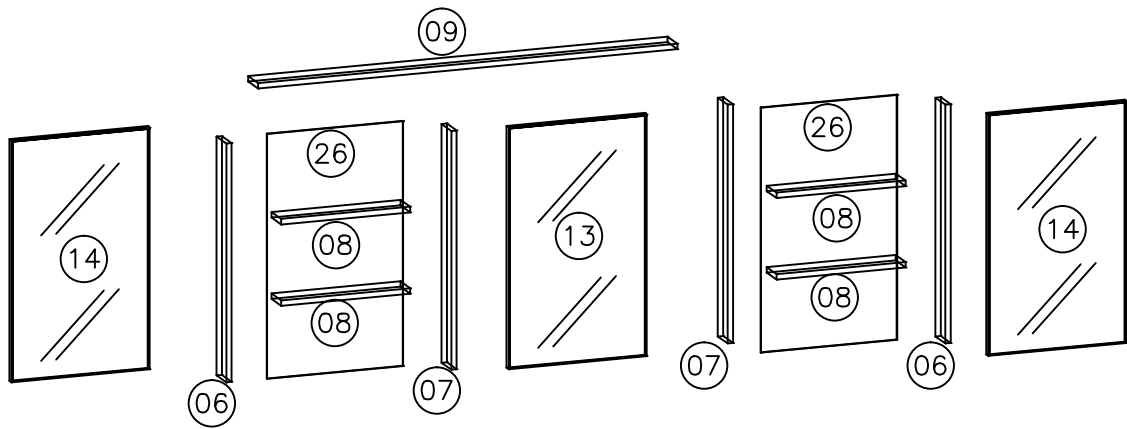







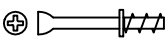
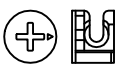
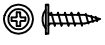

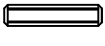
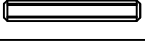
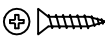



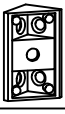

DESCRIPTION - DESCRIPCIÓN			QTY.	BOX
01	Top bottom panel	Panel superior	1	2
02	Right side	Lateral derecha	1	1
03	Left side	Lateral izquierda	1	1
04	Right partition	Divisoria derecha	1	1
05	Left partition	Divisoria izquierda	1	1
06	Upper side	Parte superior	2	1
07	Upper divider	Divisor de arriba	2	1
08	Top shelf	Estante superior	4	1
09	Top	Pieza de techo	1	2
10	Baseboards	Zócalos	4	2
11	Crosspiece	Travesaño	1	2
12	Strengthening	Reforzamiento	1	2
13	Mirror part	Pieza del espejo	1	2
14	Doors	Puertas	2	2
15	Larger narrow drawer front	Frente de cajón estrecho más grande	1	1
16	Smaller narrow drawer front	Frente de cajón estrecho más pequeño	2	1
17	Smaller right side of drawer	Lado derecho del cajón más pequeño	3	1
18	Smaller left side of drawer	Lado izquierdo del cajón más pequeño	3	1
19	Larger narrow back drawer	Cajón trasero más grande y estrecho	1	2
20	Smaller and narrower back drawer	Cajón trasera más pequeño y estrecho	2	2
21	Smaller Drawer Front	Frente de cajón más pequeño	6	1
22	Drawer side larger right	Lado del cajón mayor derecho	6	1
23	Drawer side larger left	Lado del cajón mayor izquierdo	6	1
24	Larger back drawer	Cajón trasero más grande	6	2
25	Lower rear panel	Panel inferior trasero	2	1
26	Upper rear panel	Panel arriba trasero	2	2
27	Bottom drawer smaller	Cajón inferior más pequeño	8	1
28	Bottom drawer larger	Cajón inferior más grande	1	2

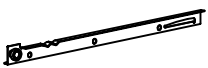

IDENTIFICATION OF ACCESSORIES / IDENTIFICACION DE ACCESORIOS

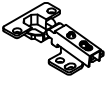
Note: the separation of the accessories before starting the assembly will facilitate it.

Nota: la separación de los accesorios antes de empezar el armado facilitará el mismo.

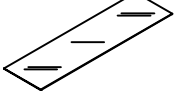
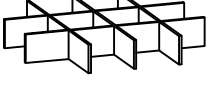
NUMBER	DESCRIPTION		QTY.
PE18		Structural screw/Tornillo estructural (5x40mm)	50
PM		Simple minifix screw/Tornillo minifix simple	26
TM		Drum lock/Tambor minifix	26
PF4		Flanged head screw/Tornillo cabeza flangeada (3,5x16mm)	2
PC3		Flat head screw/Tornillo cabeza plana (3,5x14mm)	96
C1		Wooden dowel/Pin (6x30mm)	86
C2		Cavilha/Tarugo/Dowel 6x50mm	2
PC5		Flat head screw/Tornillo cabeza plana (4,0x20mm)	18
PC10		Flat head screw/Tornillo cabeza plana (4,5x50mm)	2
BG		Bushing/Tapón	2
SF		Mounting bracket/Soporte de montaje	2
ANY		Clamp/Abrazadera	1
CG		Angle bracket/Cantón	6
S5		triangular support/soporte triangular	18
SD		Shoe black/Zapata negra	8
PR2		Nail/Clavo (12x12mm)	8
PR1		Nail/Clavo (10x10mm)	83
FC		Shore Fixer/Fijador de costa	6
CM1A		Right Drawer slide/Corredera lateral derecha (350mm)	9
CM1B		Left Drawer slide/Corredera cajón izquierda (350mm)	
CM1C		Metallic left slide/Corredera lateral izquierda (350mm)	
CM1D		Metallic right slide/Corredera lateral derecha (350mm)	
D011		Hinge/Bisagra (35mm)	4
		Screw/Tornillo (4,0x14mm)	24
TP1		Adhesive bore patch/Tapón adhesivo 19mm	26
TP2		Adhesive bore patch/Tapón adhesivo 13mm	20
CZ3		Allen key/Llave allen	1
V		Glass/Vidrio	1
AG		Afastador de gaveta/Retractor de cajón/Drawer retractor	1



ATTENTION

To facilitate the assembly process, separate and organize all boards before you start.

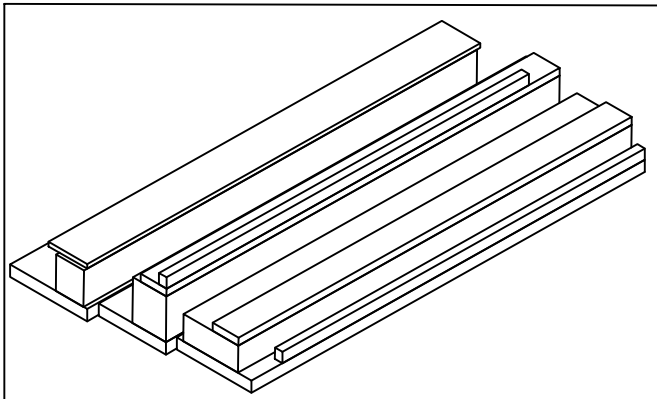

Para facilitar el armado, separa y organiza todas las tablas antes de empezar.

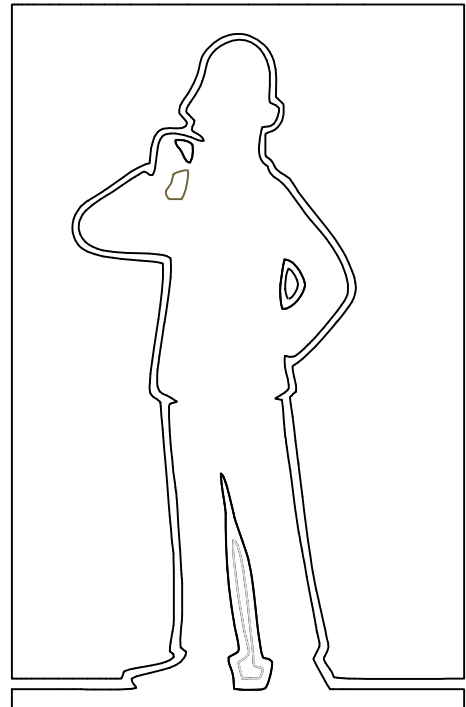

PRE-ASSEMBLY/PRE-ARMADO

1. Fix **wooden dowels** (C1) and **wooden dowels** (C2) to the **side** (06).
 Fije los **tacos de madera** (C1) y los **tacos de madera** (C2) al **tabique lateral** (06).

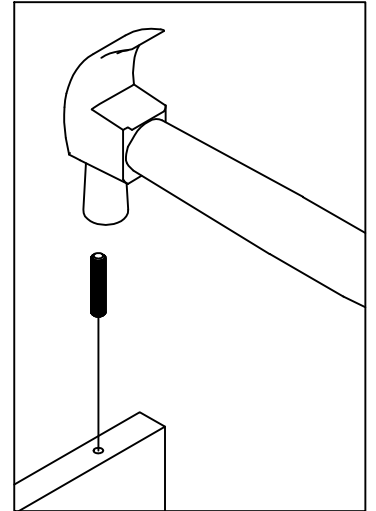
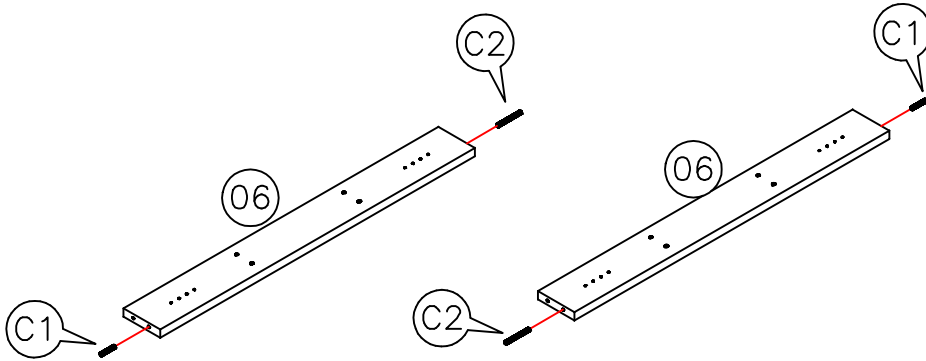

C1  2 C2  2

2. Fix **wooden dowel** (C1) to **Upper partition** (07).
 Fijarpin (C1) a **Partición superior** (07).

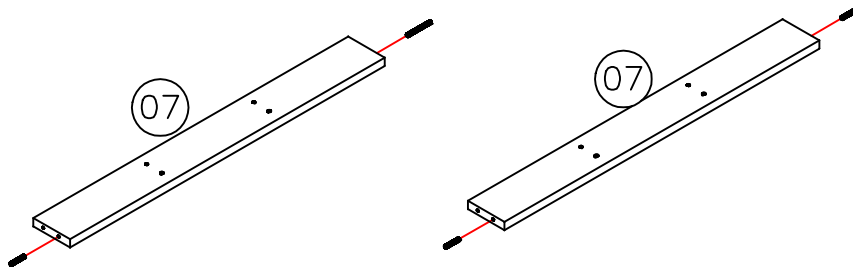

C1  4

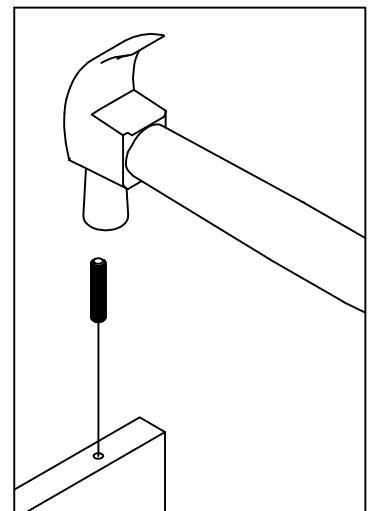

3. Fix **wooden dowel** (C1) to **Baseboards** (10).
Fijar **pin** (C1) a **Zócalos** (10).

4x

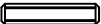
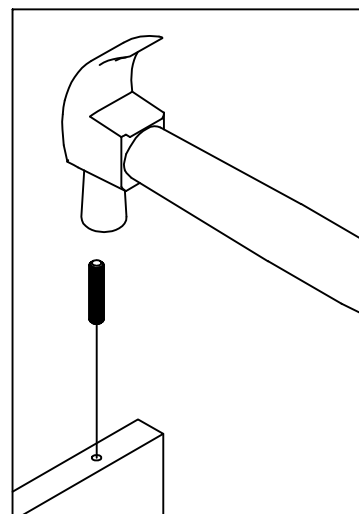
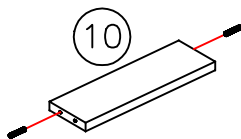
C1  8

4. Fix **wooden dowel** (C1) to **Top shelf** (08).
Fijar **pin** (C1) a **Estante superior** (08).

4x

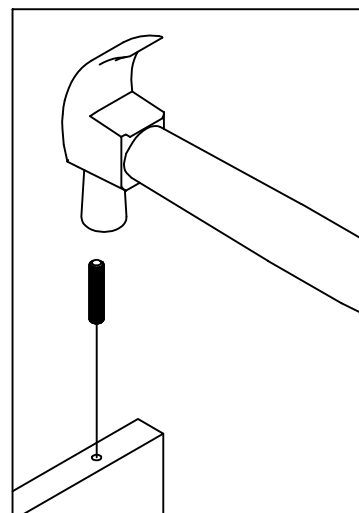
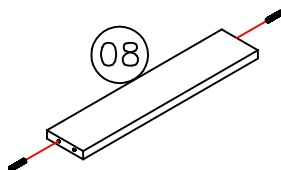
C1  8

5. Fix **wooden dowel** (C1) to **Crosspiece** (11).
Fijar **pin** (C1) a **Travesaño** (11).

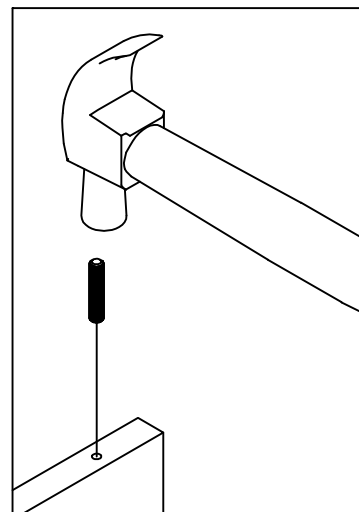
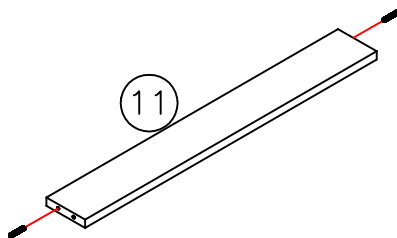
C1  2

6. Fix the **wooden dowel** (C1) and the **small plastic foot** (SD) and the **metallic right slide** (CM1D) to the **right side** (02).

Fije **pin** (C1) y el **pie pequeño de plástico** (SD) y la **corredera metálica derecha** (CM1D) en el **lado derecho** (02).

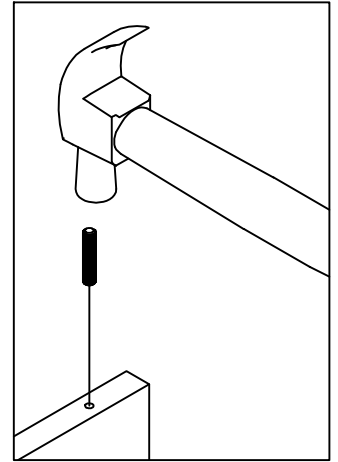
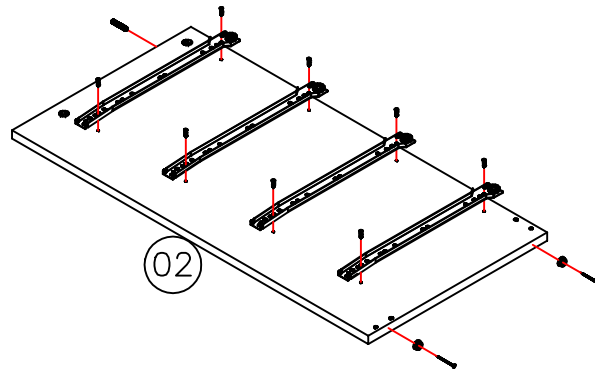

- C1 1 CM1D 4 PC3 8 SD 2 PR2 2

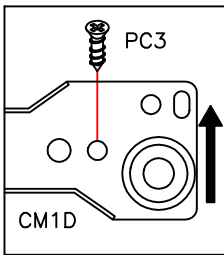

Note: the two upper holes have to be facing up.
Nota: Los dos agujeros superiores deben estar hacia arriba.

7. Fix the **wooden dowel** (C1) and the **small plastic foot** (SD) and the **metallic left slide** (CM1C) to the **left side** (03).

Fije **pin** (C1) y el **pie pequeño de plástico** (SD) y la **corredera metálica izquierda** (CM1C) en el **lado izquierdo** (03).

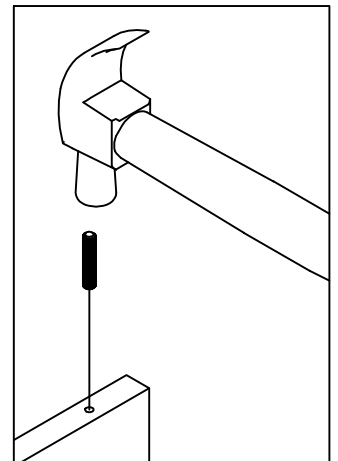
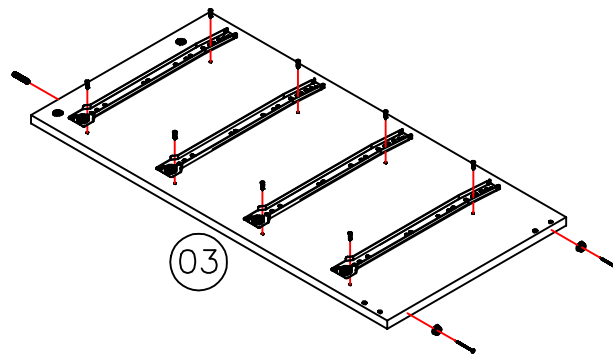

- C1 1 CM1C 4 PC3 8 SD 2 PR2 2

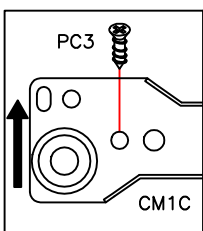

Note: the two upper holes have to be facing up.
Nota: Los dos agujeros superiores deben estar hacia arriba.

8. Fix the **small plastic foot** (SD) and the **metallic right slide** (CM1D) **metallic left slide** (CM1C) to the **Right partition** (04).

Fije **pie pequeño de plástico** (SD) y la **corredera metálica derecha** (CM1D) **corredera metálica izquierda** (CM1C) en el **Divisoria derecha** (04).

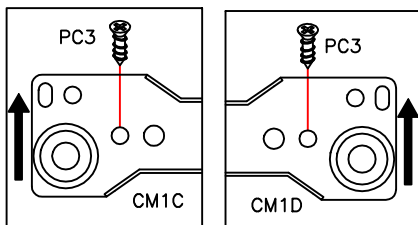
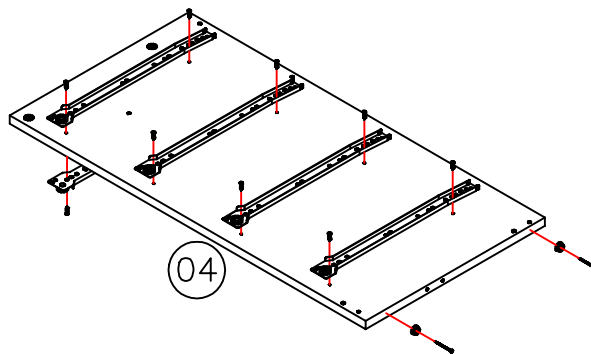

Note: the two upper holes have to be facing up.
Nota: Los dos agujeros superiores deben estar hacia arriba.

9. Fix the **small plastic foot** (SD) and the **metallic right slide** (CM1D) **metallic left slide** (CM1C) to the **left partition** (05).

Fije **pie pequeño de plástico** (SD) y la **corredera metálica derecha** (CM1D) **corredera metálica izquierda** (CM1C) en el **Divisoria izquierda** (05).

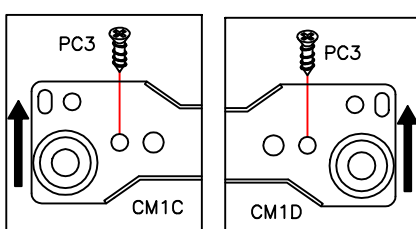
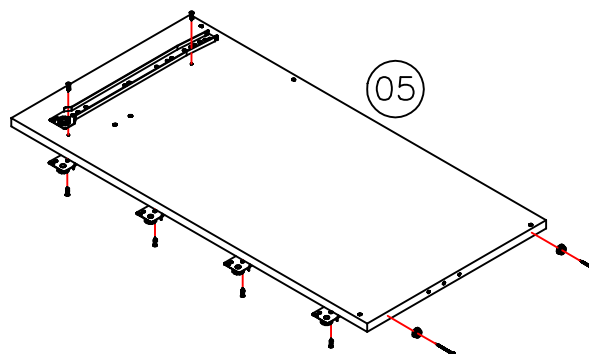

Note: the two upper holes have to be facing up.
Nota: Los dos agujeros superiores deben estar hacia arriba.

10. Fix **simple minifix screw** (PM) to **top** (01).
Fijar tornillo minifix simple (PM) a **tapa** (01).

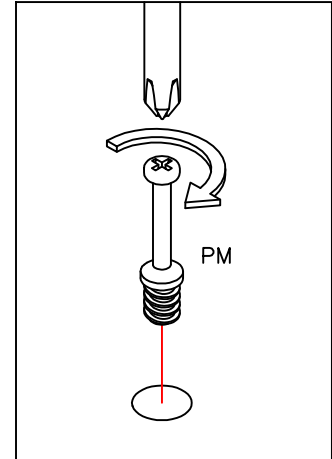
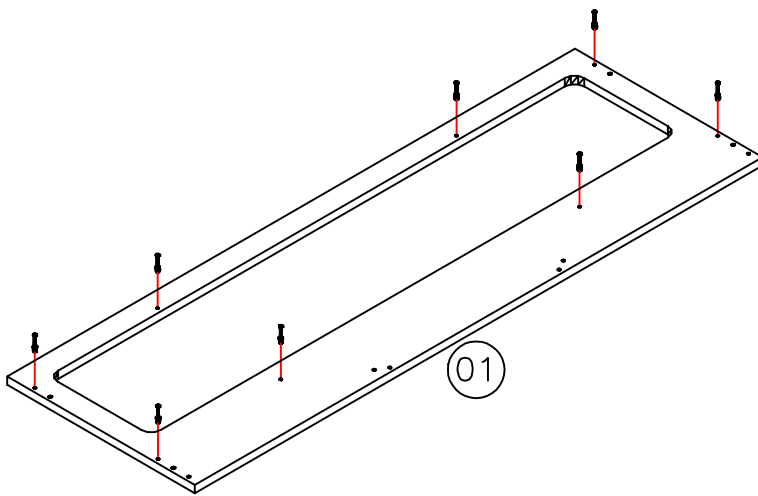

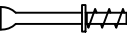
PM  8

11. Fix **wooden dowel** (C1) to **right side of drawer** (17) 3x and **left side of drawer** (18) 3x.

Fijar **pin** (C1) a **lateral derecha de cajón** (17) 3x y **lateral izquierda de cajón** (18) 3x.

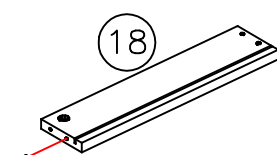
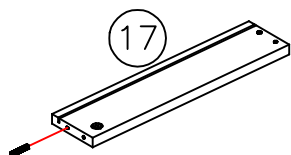

3x

C1  6

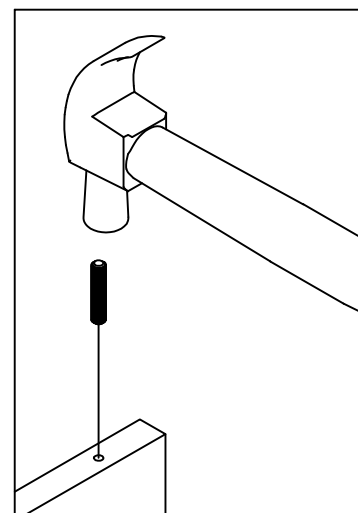

12. Fix **wooden dowel** (C1) to **right side of drawer** (22) 6x and **left side of drawer** (23) 6x.

Fijar **pin** (C1) a **lateral derecha de cajón** (22) 6x y **lateral izquierda de cajón** (23) 6x.

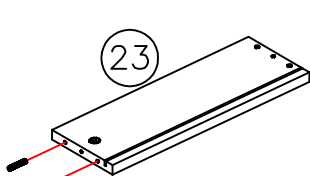
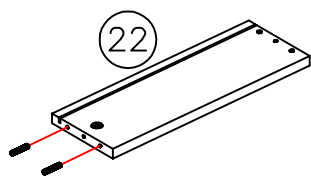

6x

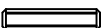
C1  24

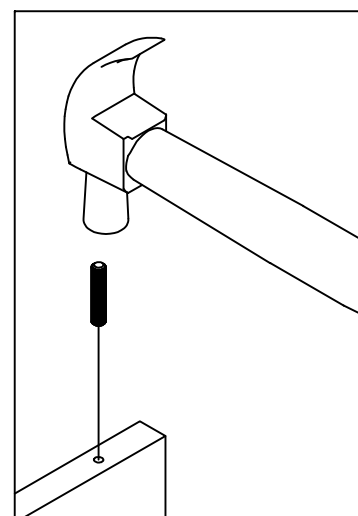

13. Fix **wooden dowel** (C1) to **Larger narrow back drawer** (19).

Fijar **pin** (C1) a **Cajón trasera más grande y estrecho** (19).

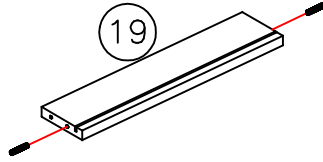

C1  2

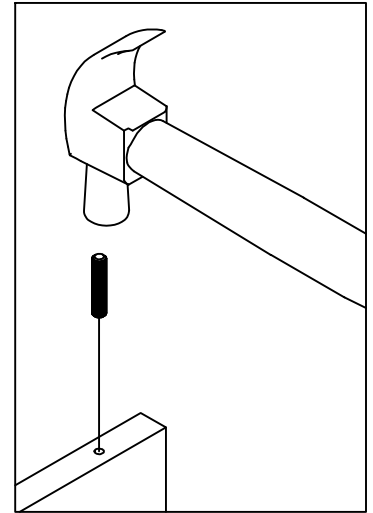

13. Fix **wooden dowel** (C1) to **Smaller and narrower back drawer** (20) 2x.

Fijar **pin** (C1) a **Cajón trasera más pequeño y estrecho** (20) 2x

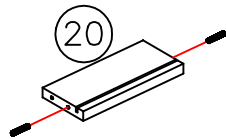

2x

C1  4

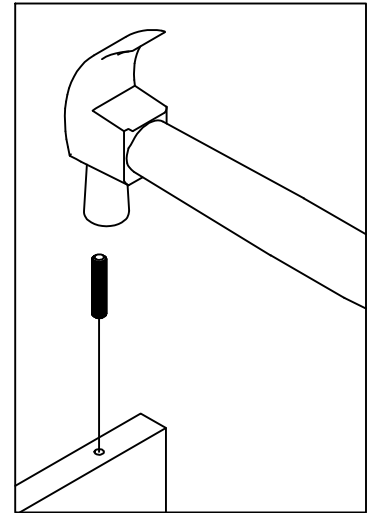

13. Fix **wooden dowel** (C1) to **Larger back drawer** (24) 6x

Fijar **pin** (C1) a **posterior de cajón** (24) 6x

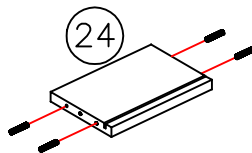

6x

C1  24

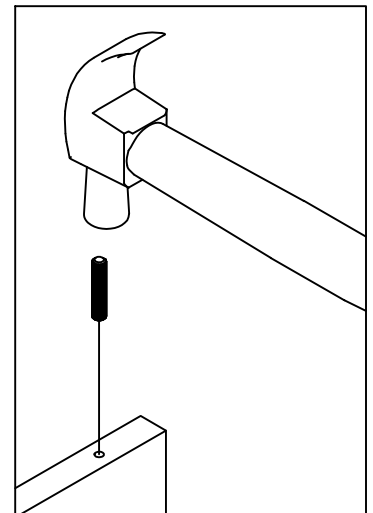

13. Fix **simple minifix screw** (PM) to **Larger narrow drawer front** (15).
 Fijar **tornillo minifix simple** (PM) a **Frente de cajón estrecho más grande** (15).

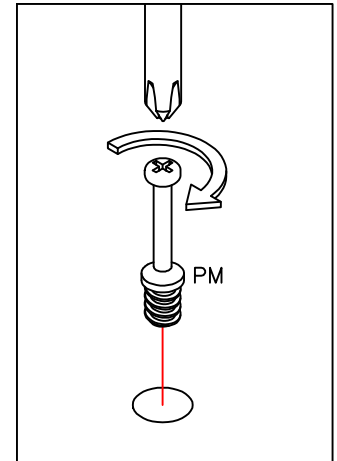
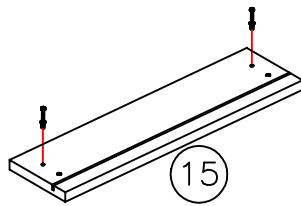

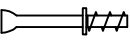
PM ⊕  2

14. Fix **simple minifix screw** (PM) to **Smaller narrow drawer front** (16) 2x.
 Fijar **tornillo minifix simple** (PM) a **Frente de cajón estrecho más pequeño** (16) 2x.

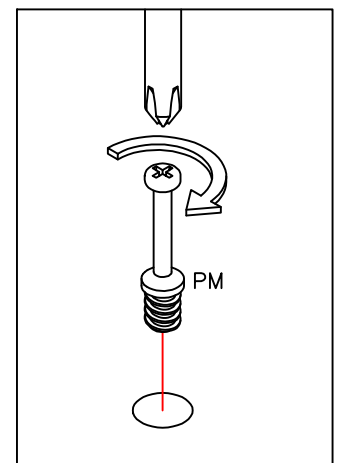
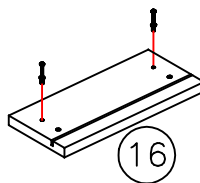

2x

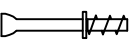
PM ⊕  4

15. Fix **simple minifix screw** (PM) to **Smaller drawer front** (21) 6x
 Fijar **tornillo minifix simple** (PM) a **Frente de cajón más pequeño** (21) 6x

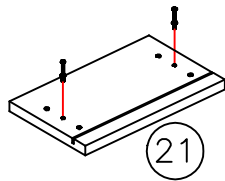

6x

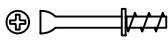

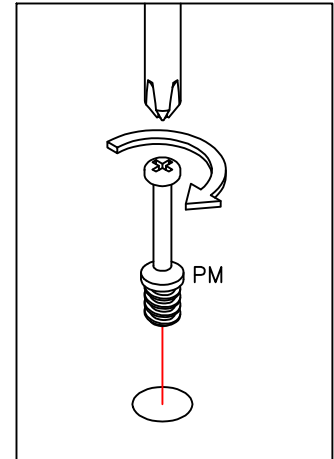
PM  12

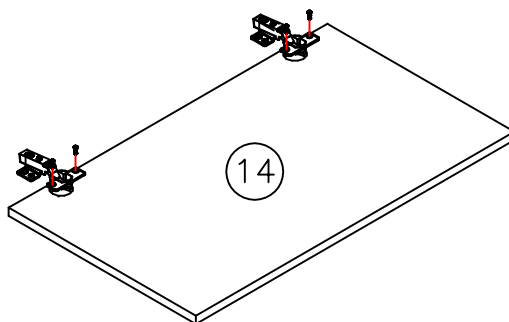

16. Fix **Hinge** (PM) to **Door** (14) 2x.
 Fijar **Bisagra** (PM) a **puerta** (14) 2x.



2x

D011  4 D015  8

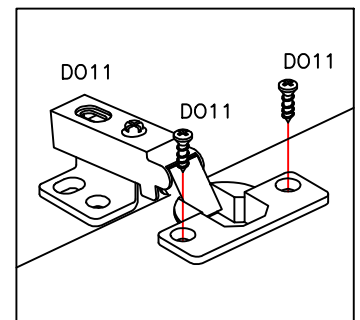

ASSEMBLY/ARMADO

17. Attach the **shelves** (08) to the **partition** and **upper side** (06)
 Fije los **estantes** (08) al **tabique** y a la **parte superior** (06)

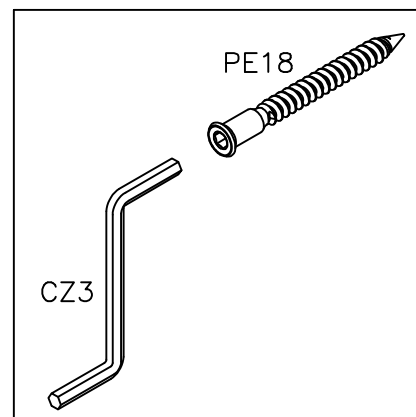
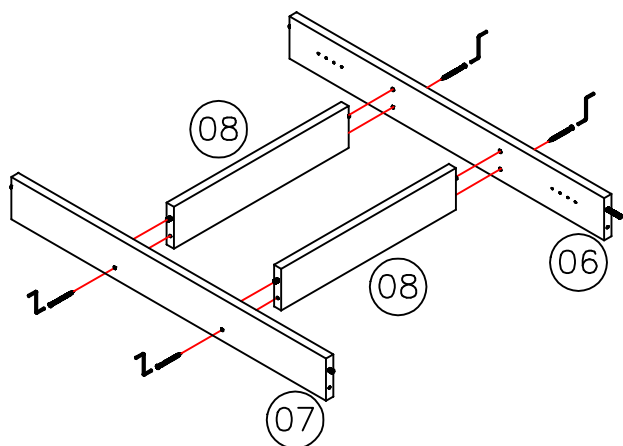

CZ3  1 PE18  4 TP2  4

18. Attach the **shelves** (08) to the **partition** and **upper side** (06)
 Fije los **estantes** (08) al **tabique** y a la **parte superior** (06)

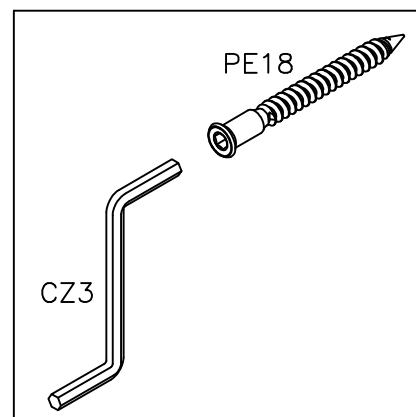
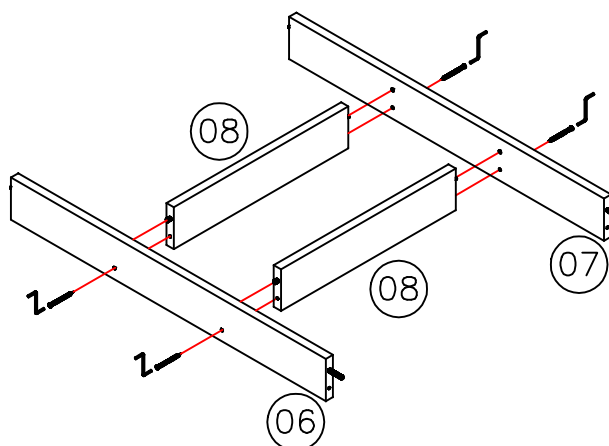

CZ3  1 PE18  4 TP2  4

19. Fix the **top piece** (09) to the **previous assembly**.

Fijar la parte **superior** (09) al conjunto anterior.

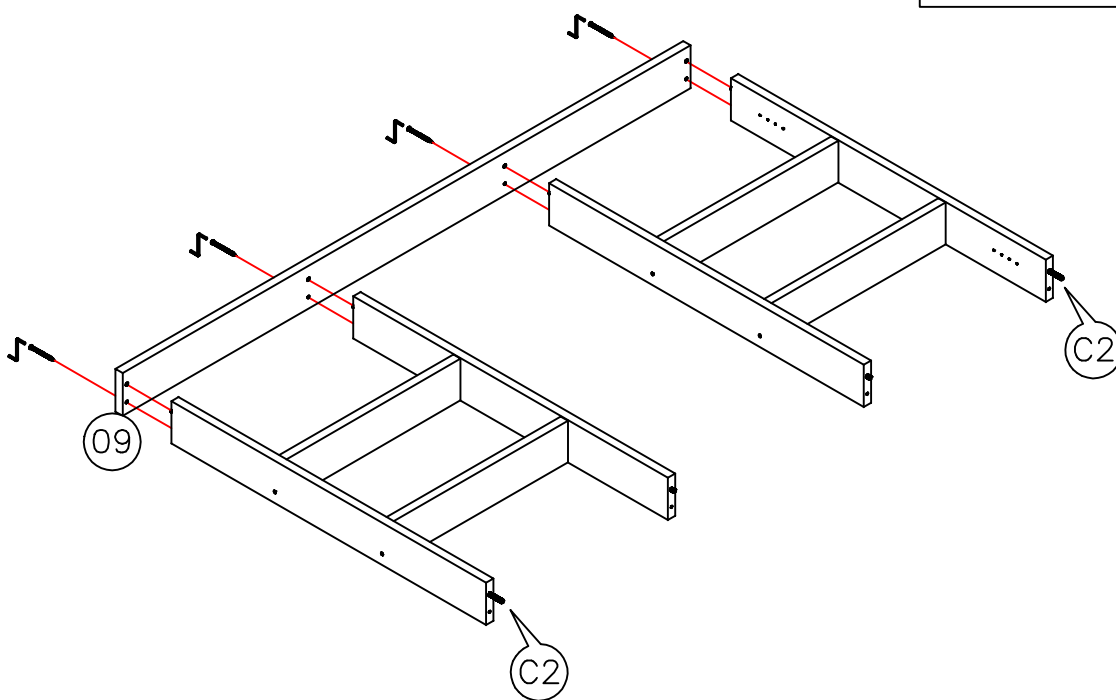
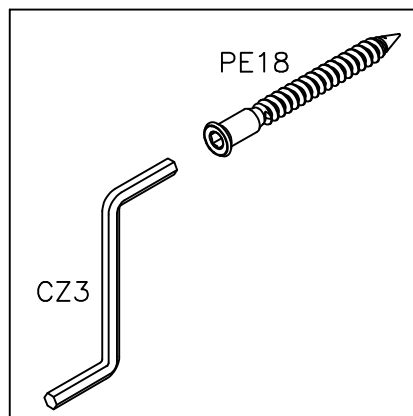

1



4



4

20. Fix to the previous assembly to the top (01).
 Fijar el conjunto anterior en la Tapa (01).

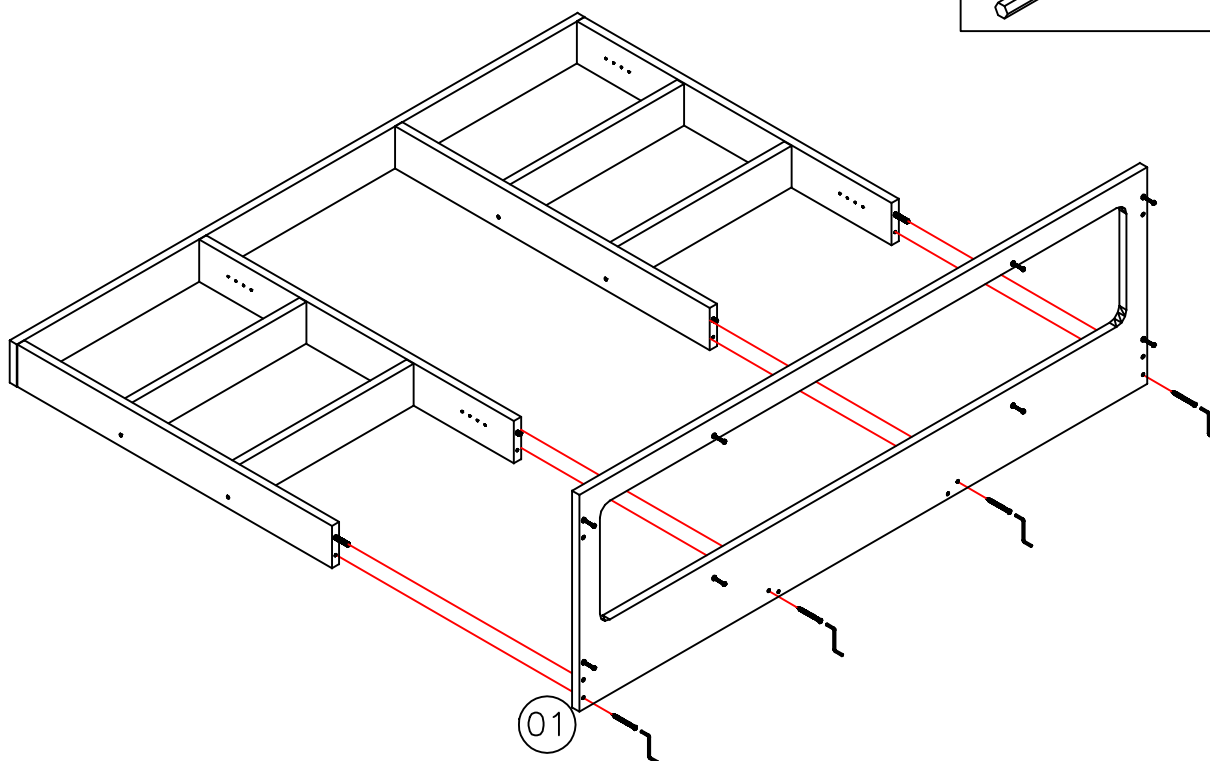
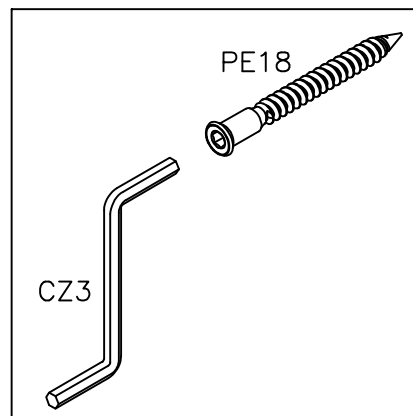

CZ3  1 PE18  4

22. Attach the upper assembly to the previous assembly
 21. Attach the lower parts.
 Fijar el conjunto superior al conjunto anterior.
 Coloca las partes inferiores.

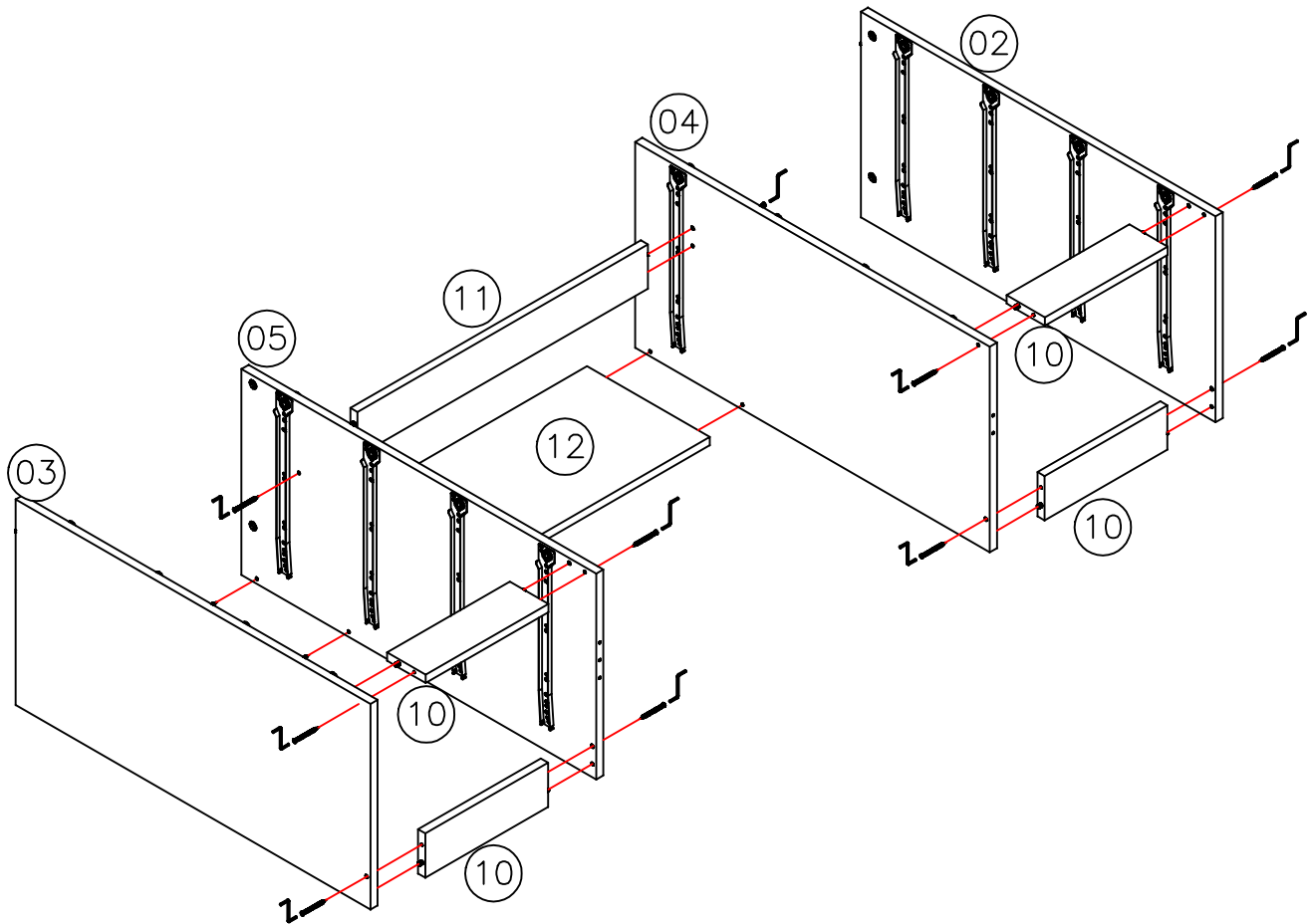
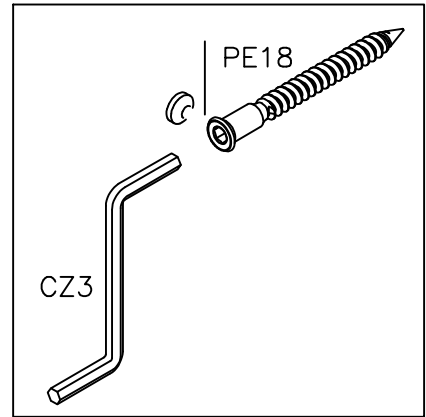

1

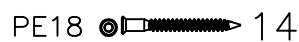

14

TP2



8

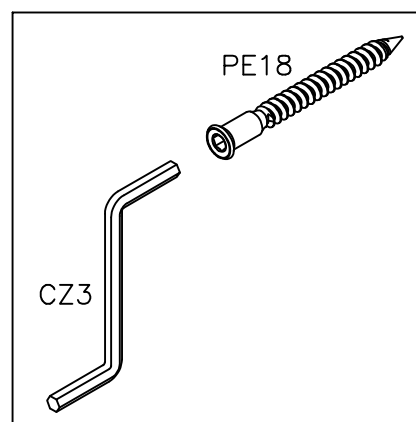
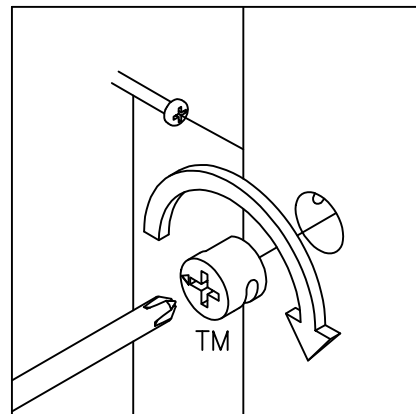
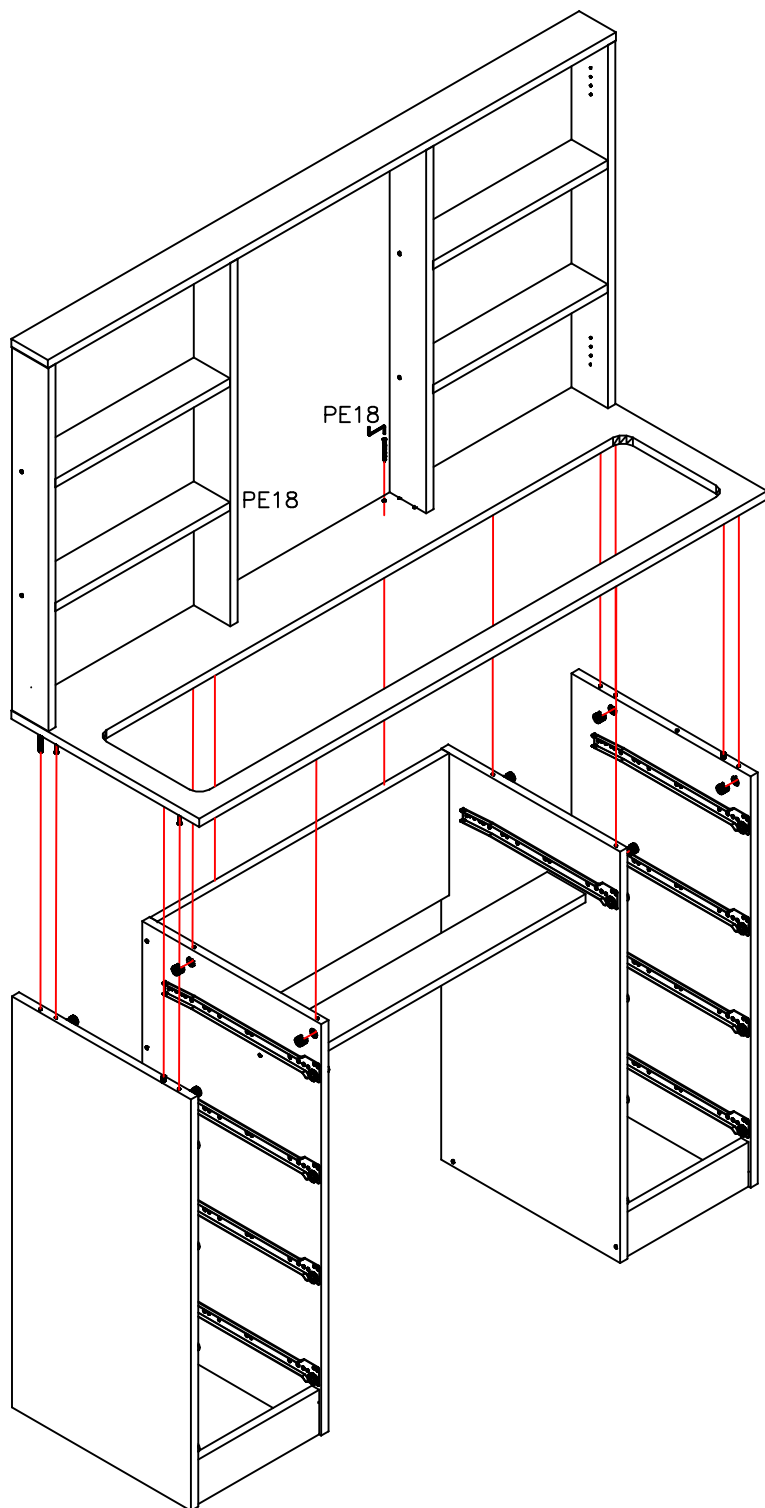

TM



8

TP1



8

CZ3



1

PE18



2

23. Fixing the angle brackets.
Fijación de las Cantón.



First attach the top brackets, and then attach the side brackets.

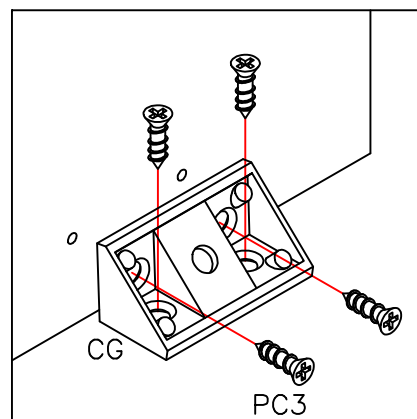
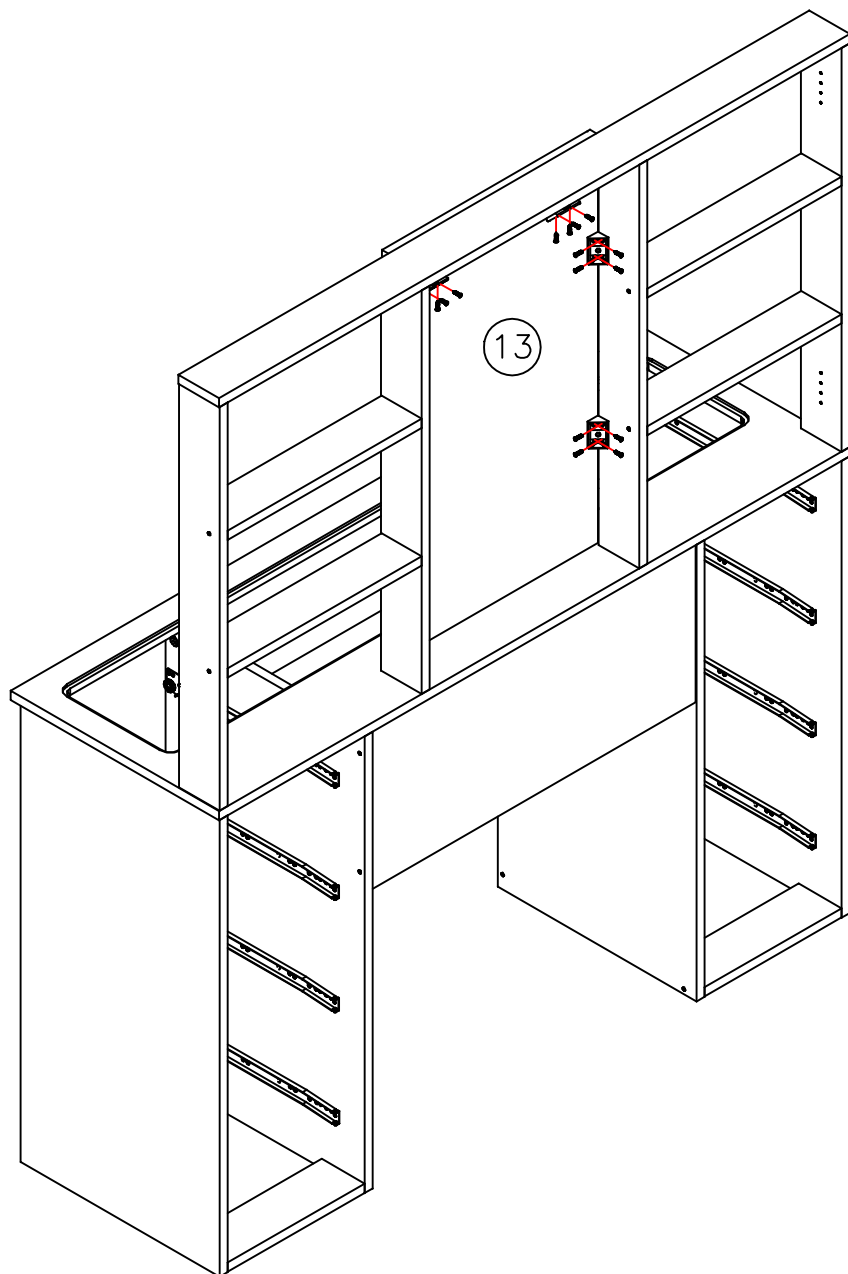

CG



6

PC3



24

24. Installation of the hinges.
 Instalación de las bisagras.

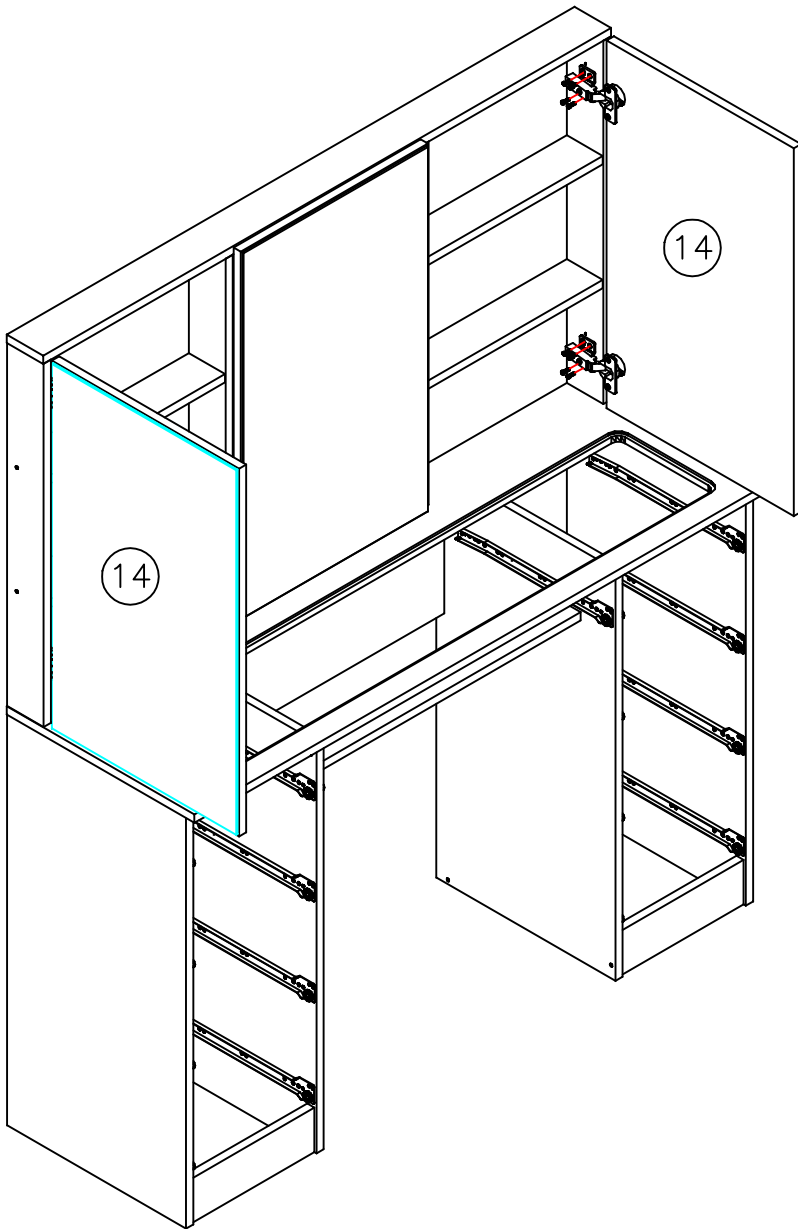

NOTAS: Utilice el agujero oblongo para posicionar la altura de la bisagra. Y, por último, cuando la puerta esté bien colocada, utilice el orificio circular para asegurarse de que no se mueve.

NOTE: Use the oblong edge to position at the height of the dobradiça. And for this reason, when the estiver holder is positioned in a correct way, use a circular hole to ensure that it does not loosen at the same time.

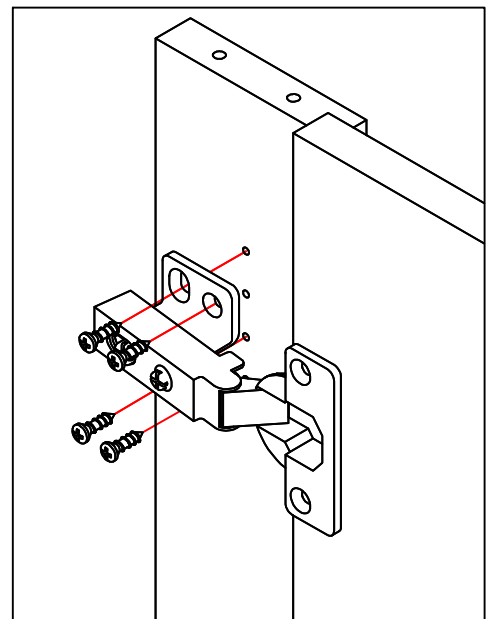
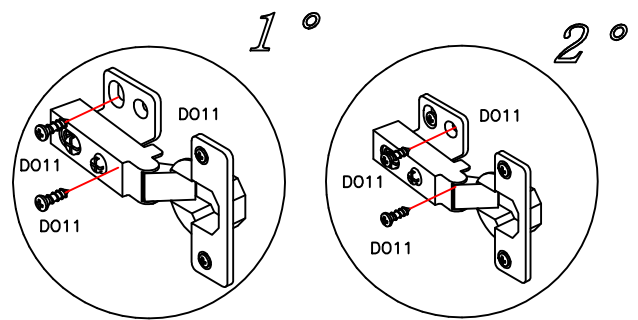

DO11 ⊕ (H) 16

Ajuste de puerto
Doors Adjustment

Ajuste de la altura
Height Adjustment

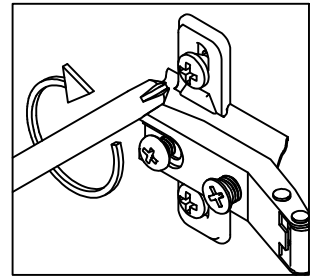
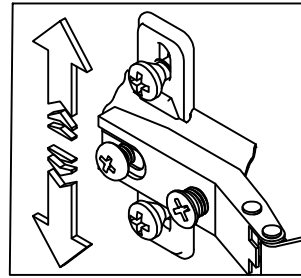
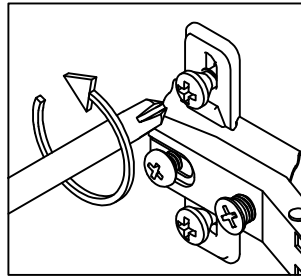
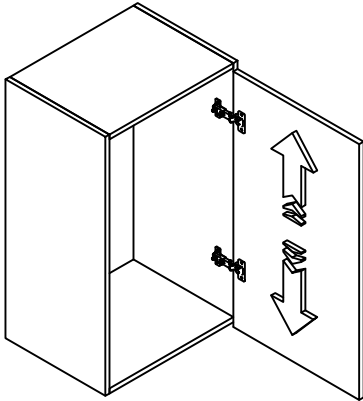

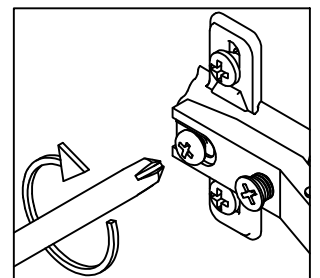
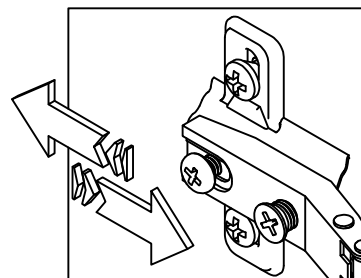
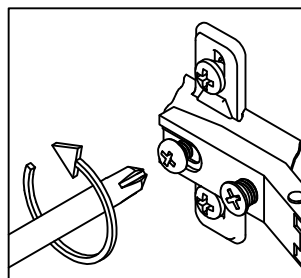
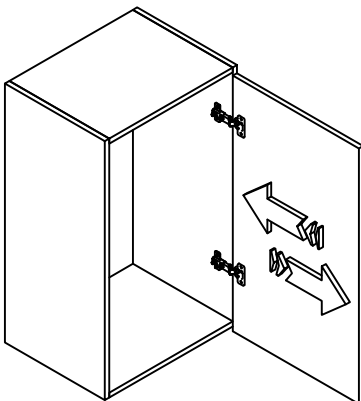

Ajuste interior
Internal Adjustment

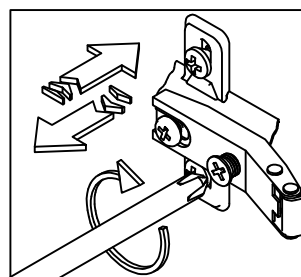
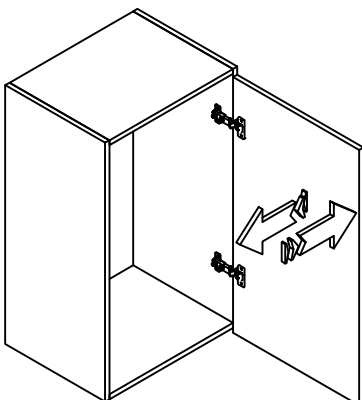

Ajuste de profundidad
Depth Adjustment

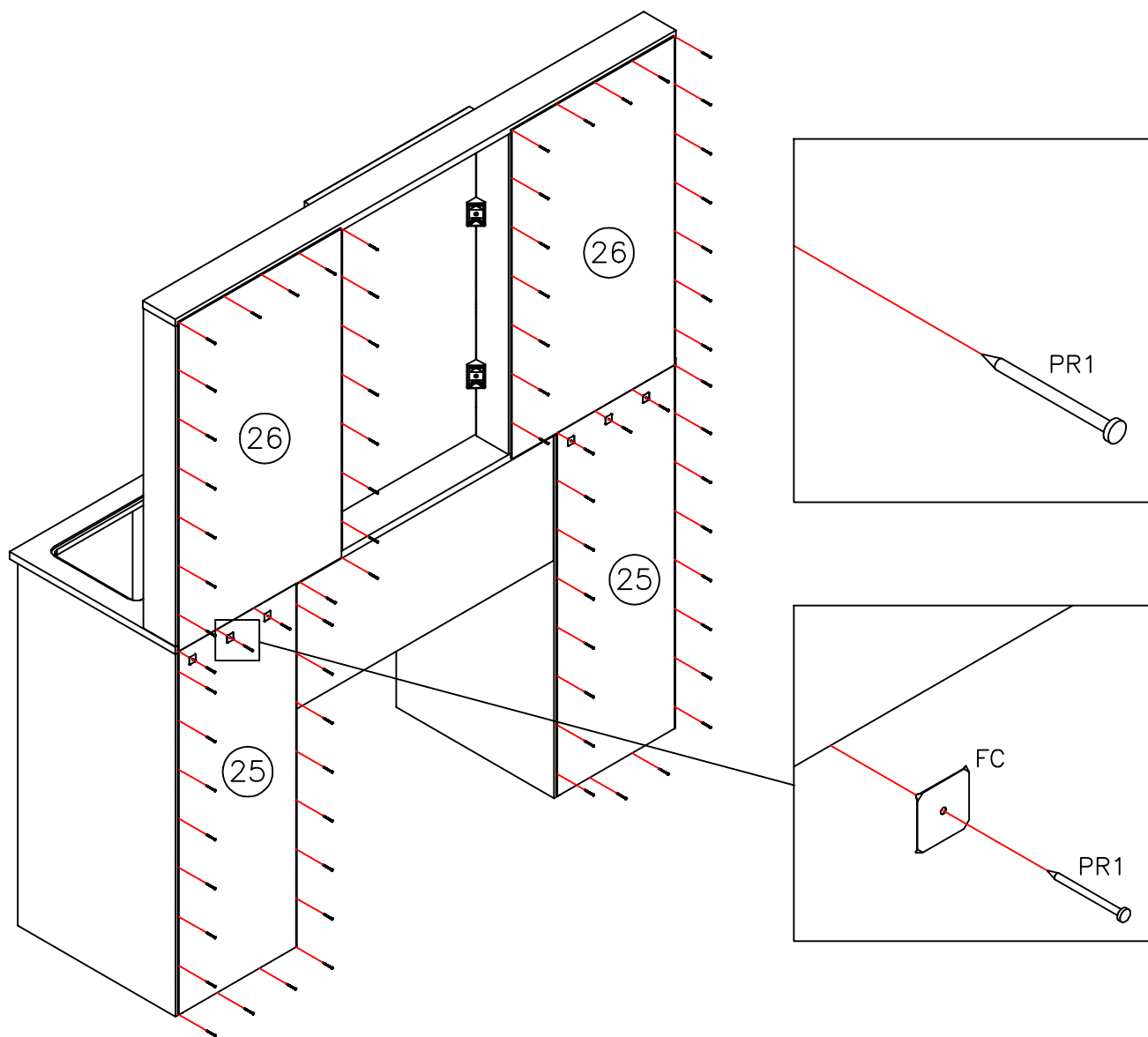

25. Fix the rear parts (25) (26) with the nail (PR1).
Fije las partes posteriores (25) (26) con el clavo (PR1).

PR1  83FC  6

26. Fix *Smaller right side of drawer* (17) and *Smaller left side of drawer* (18) to *Larger narrow back drawer* (19).

Fijar *Lado derecho del cajón más pequeño* (17) y *lado izquierdo del cajón más pequeño* (18) a *Cajón trasero más grande y estrecho* (19).

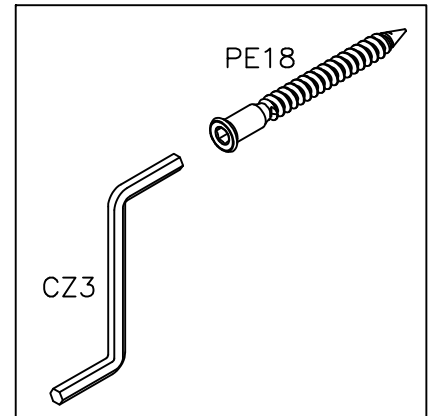
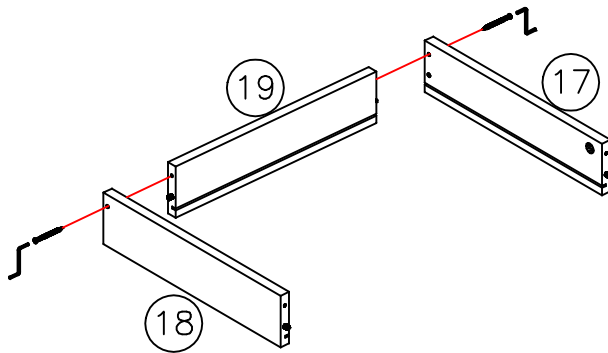

CZ3  1 PE18  2

27. Fix *Smaller right side of drawer* (17) and *Smaller left side of drawer* (18) to *Smaller and narrower back drawer* (20).

Fijar *Lado derecho del cajón más pequeño* (17) y *lado izquierdo del cajón más pequeño* (18) a *Cajón trasera más pequeño y estrecho* (20).

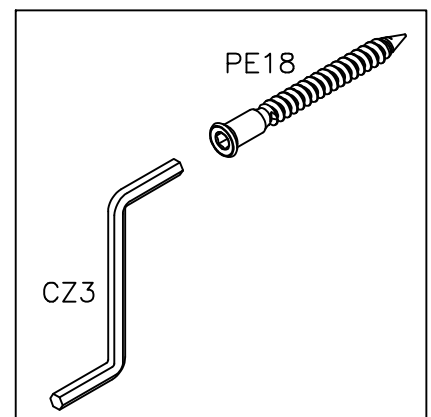
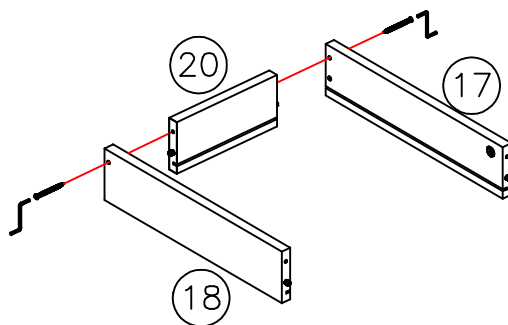

2x

CZ3  1 PE18  4

28. Fix **Drawer side larger right** (22) 6x and **Drawer side larger left** (23) 6x to **Larger back drawer** (24) 6x.

Fijar **Lado del cajón mayor derecho** (22) 6x y **Lado del cajón mayor izquierdo** (23) 6x a **Cajón trasero más grande** (24) 6x.

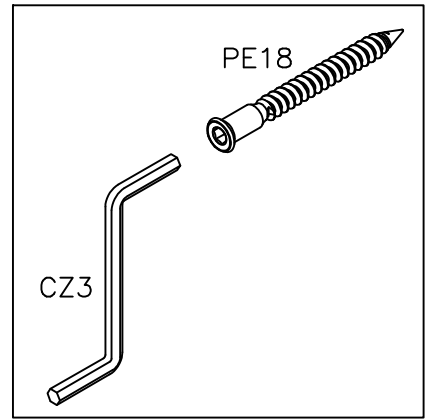
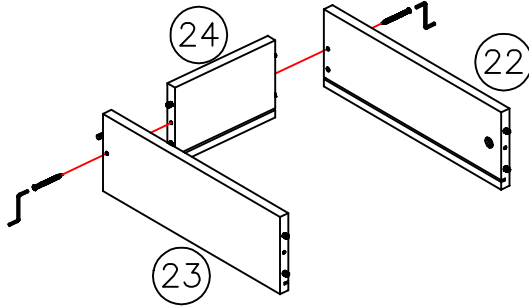

6x



1

PE18 12

29. Fix **bottom of drawer** (27) (28) to previous assembly.

Fijar **fondo de cajón** (27) (28) a ensamble previo.

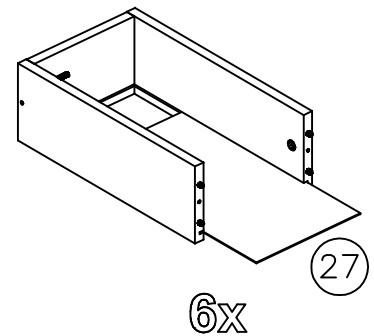
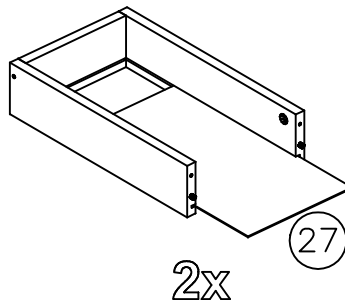
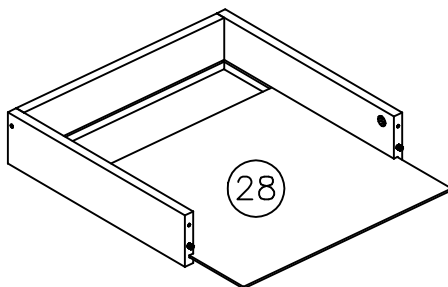

30. Fix **Larger narrow drawer front** (15) to previous assembly.
 Fije **Frente de cajón estrecho más grande** (15) a ensamble previo.

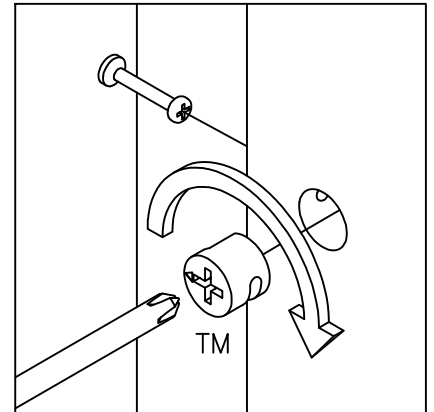
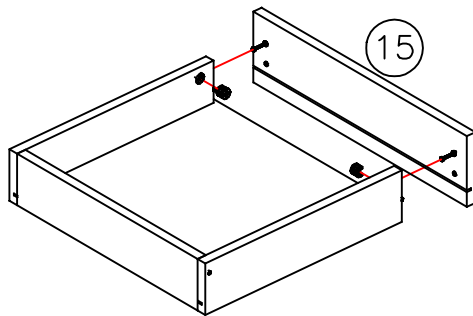

TM  2 TP1  2

31. Fix **Smaller narrow drawer front** (16) to previous assembly 2x.
 Fije **Frente de cajón estrecho más pequeño** (16) a ensamble previo 2x.

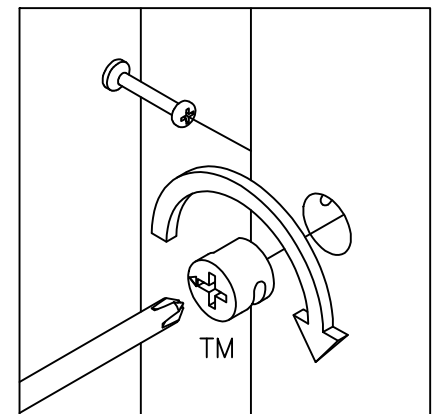
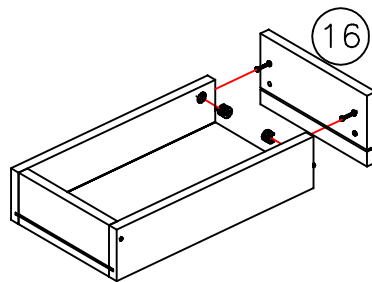

2x

TM  4 TP1  4

32. Fix **Smaller drawer front** (21) to previous assembly 6x
 Fije **Frente de cajón más pequeño** (21) a ensamble previo 6x.

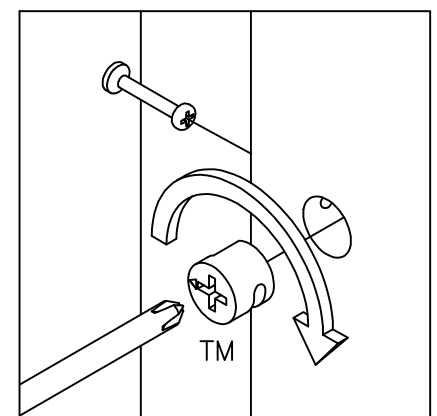
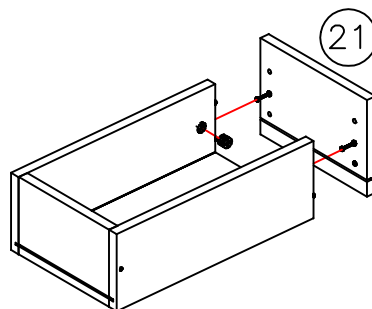

6x

TM  12 TP1  12

33. Fix the **triangular support** (S5) to the **bottom of the drawer**.
 Fijar el **soporte triangular** (S5) al **fondo del cajón**.

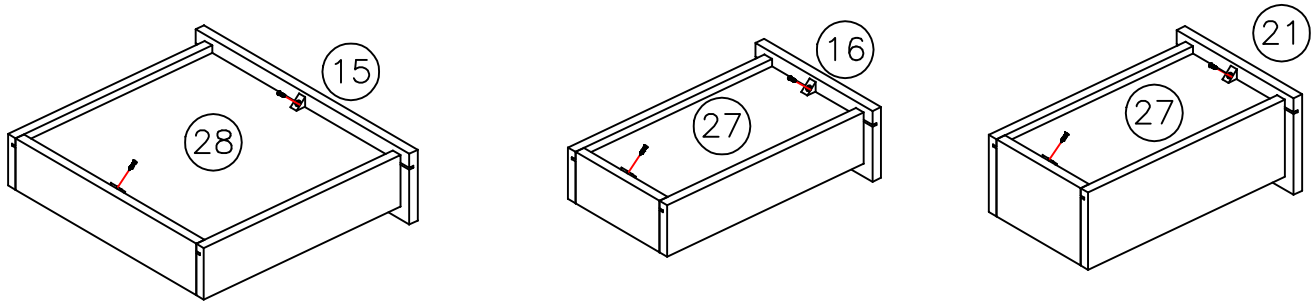

S5  18 PC5  18

34. Fix the **left drawer slide** (CM1B) and **right drawer side** (CM1A) to drawer 8x.
 Fijar el **corredera de cajón izquierda** (CM1B) y **corredera de cajón derecho** (CM1A) a cajón 8x.

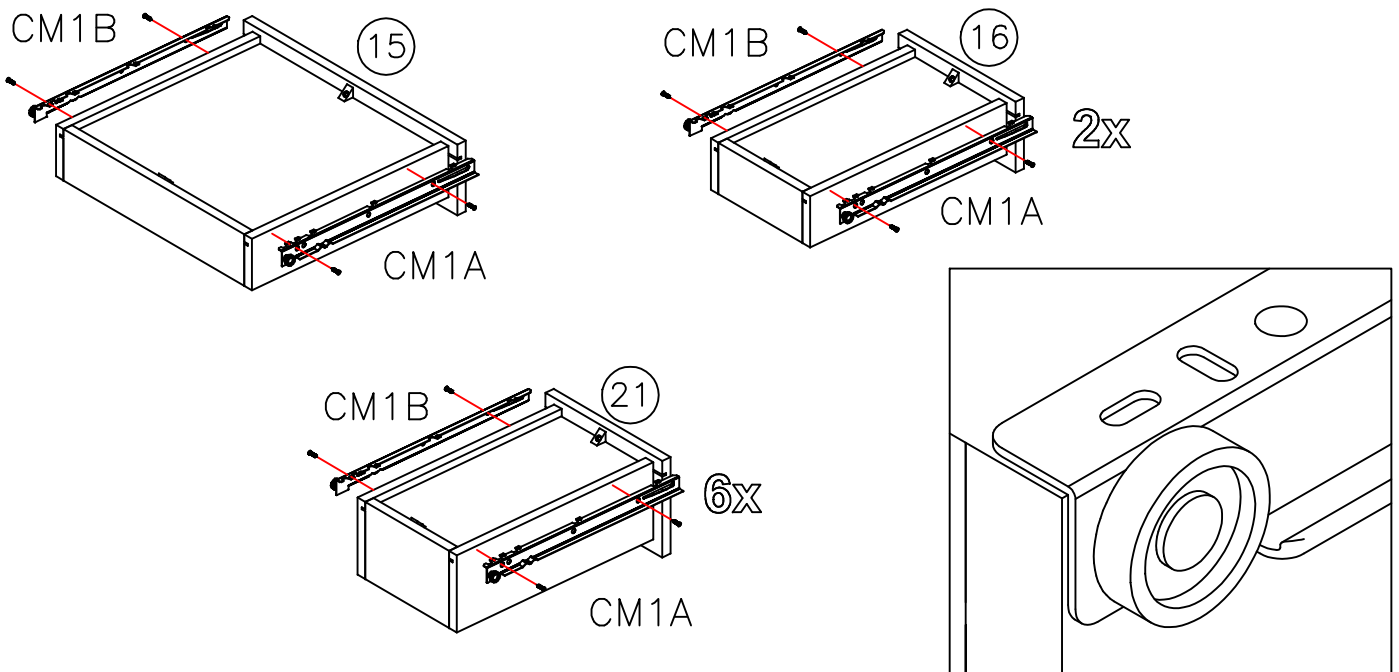

CM1A  9 CM1B  9 PC3  36



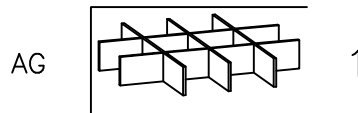
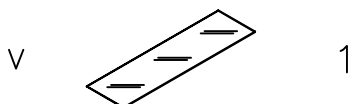
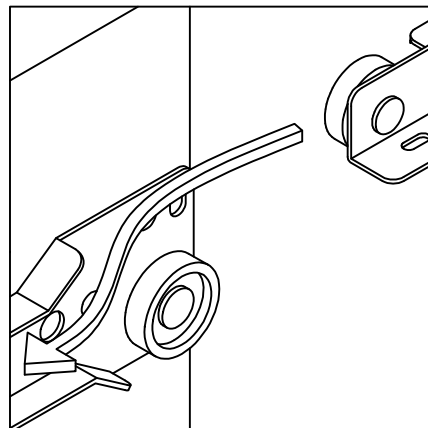
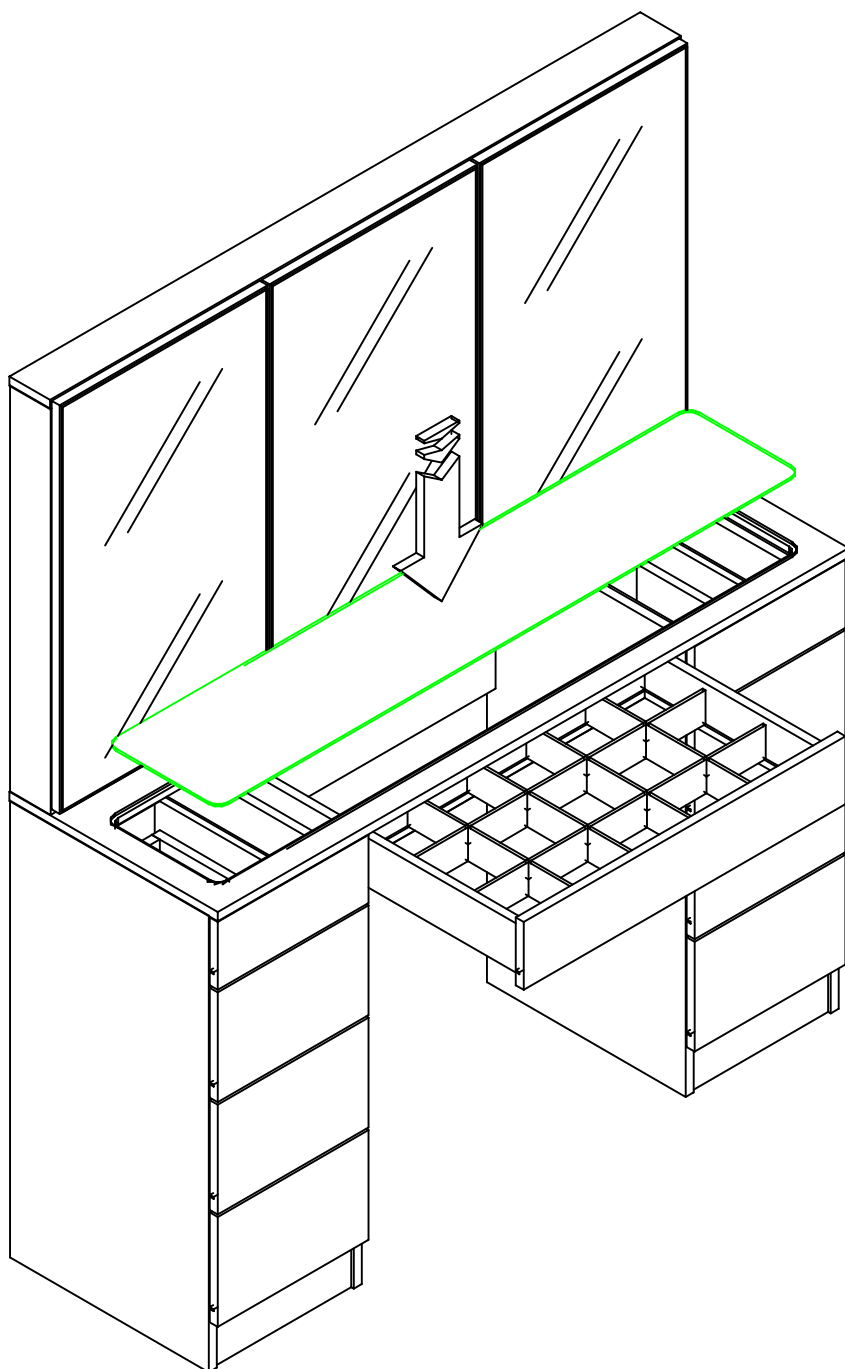

Note: Note: the missing holes must be made with the screwdriver and the corresponding screw.
 Nota: los agujeros faltantes deben hacerse con el destornillador y el tornillo correspondiente.

25. Fix **glass** to furniture.
Fijar **vidrio** a mueble.

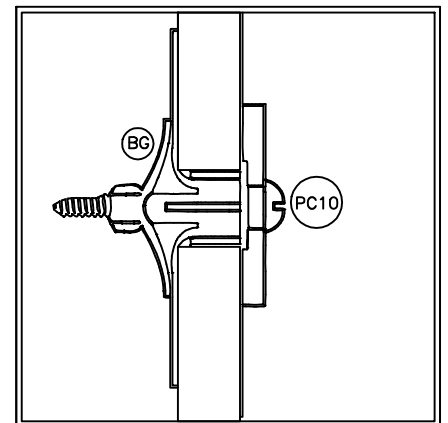
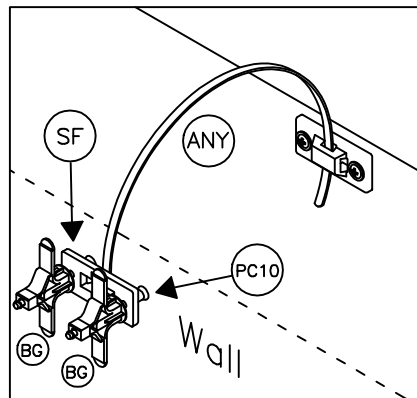
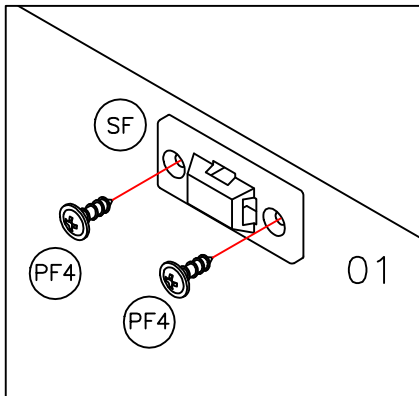
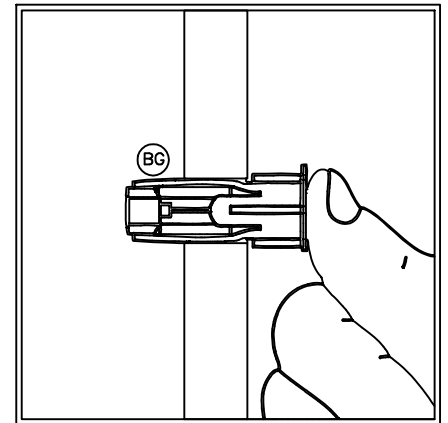
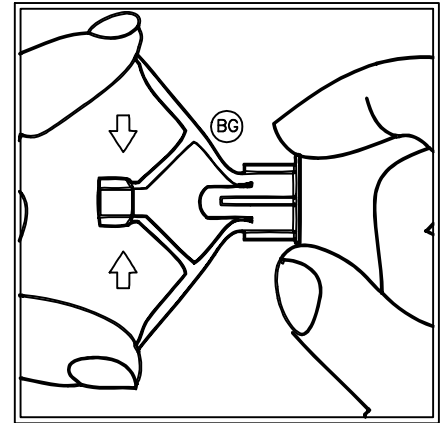
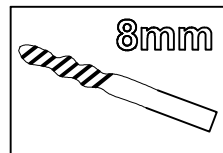
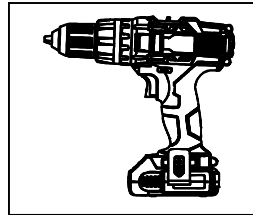
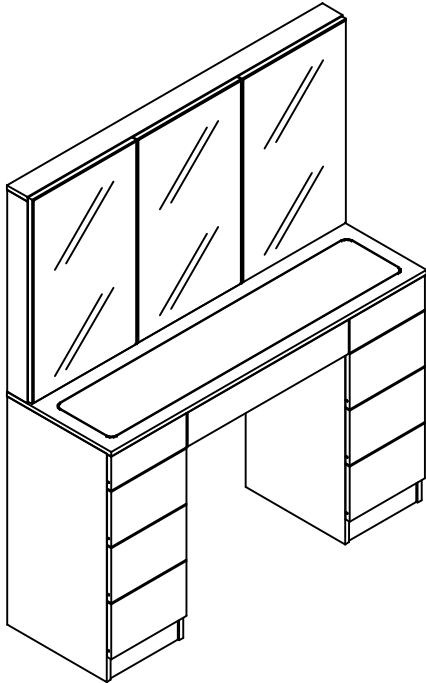

26. Andfinally fix furniture to the wall.
Y finalmente fijar mueble a la pared.



- PC10  2
- BG  2
- SF  2
- ANY  1
- PF4  2



WARNING:
For security measures it is recommended to fix the furniture to the wall to avoid overturning of it, if this happens it can cause serious or fatal injuries.

ATENCIÓN:
por medidas de seguridad se recomienda fijar el mueble a la pared para evitar volcamiento del mismo, si esto llegase a ocurrir puede causar lesiones graves o fatales.

IMPORTANT INFORMATION, PLEASE READ THE
INSTRUCTIONS CAREFULLY.

1. Fix the mounting bracket (SF) on the back of the furniture as shown in the figure, using the screws (PF4)
2. Locate a post on the wall to attach the mounting bracket (SF), place it approximately 1" below the one that is attached to the furniture. Use wall anchors (BG) and screws (PC10).
3. Move the furniture to its final position, taking care to align the wall mounting bracket with the cabinet mounting bracket. Pass the clamp (ANY) through each bracket as shown in the picture and tighten enough until it is snug.
4. Make sure all parts are tight.

INFORMACION IMPORTANTE, LEA POR FAVOR
CUIDADOSAMENTE LAS INSTRUCCIONES.

1. Fije el soporte de montaje (SF) en la parte posterior del mueble como se muestra en la figura, usando los tornillos (PF4)
2. Ubique un poste en la pared para sujetar el soporte de montaje (SF), colóquelo aproximadamente a 1 "debajo del que está sujeto al mueble. Utilice anclajes de pared (BG) y tornillos (PC10).
3. Mueva el mueble a su posición final, teniendo cuidado de alinear el soporte de montaje en pared con el soporte de montaje del gabinete. Pase la abrazadera (CUALQUIERA) a través de cada soporte como se muestra en la imagen y apriete lo suficiente hasta que quede ajustado.
4. Asegúrese de que todas las piezas estén apretadas.

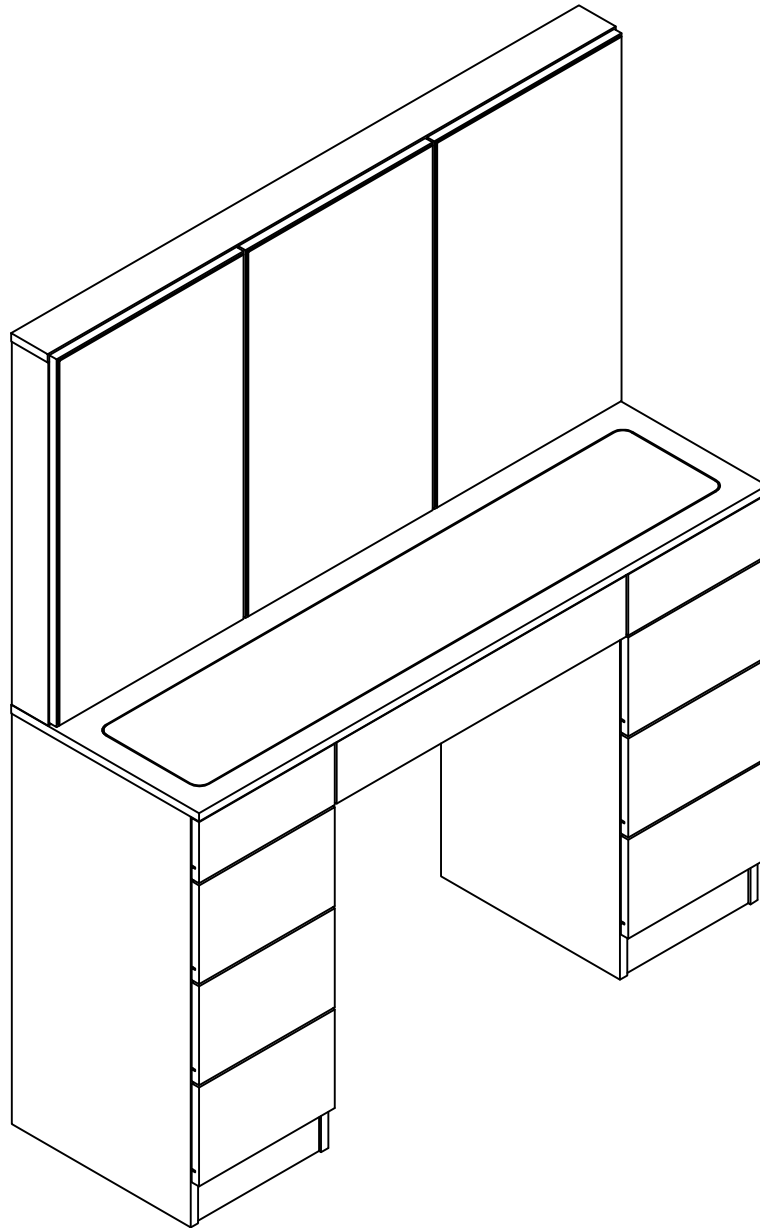

***Congratulations, you have assembled your DRESSING TABLE WITH MIRROR!!!
¡¡¡Felicitaciones, has armado tu Tocador con Espejo!!!***

1637 Boahaus DRESSING TABLE WITH MIRROR Warranty

6-Months Limited Warranty

a. Boahaus, LLC provides limited warranty coverage to the original purchaser of this product for a period of six months from the date of purchase against defects in materials or workmanship of Boahaus furniture components. As used in this Warranty, "defect" means imperfections in components which substantially impair the utility of the product. This Warranty gives you specific legal rights, and you may also have other rights which vary from state to state.

b. There is no warranty coverage for defects or conditions that result from the failure to follow product assembly instructions, information or warnings, misuse or abuse, intentional damage, fire, flood, alteration or modification of the product, or use of the product in a manner inconsistent with its intended use, nor any condition resulting from incorrect or inadequate maintenance, cleaning, or care. There is also no warranty coverage for rented products or any products purchased "used" or "as is", at a distress or going-out-of business sale, or from a liquidator.

c. As the exclusive remedy under this Warranty, Boahaus will (at its sole option) repair, replace or refund the value of any defective furniture component. Boahaus may require independent confirmation of the claimed defect and proof of purchase. Replacement parts will be warranted for only the remaining period of the original Warranty. BOAHAUS SHALL HAVE NO LIABILITY for ANY INCIDENTAL OR CONSEQUENTIAL DAMAGES OF ANY KIND and all such damages are EXCLUDED FROM THIS WARRANTY, such as loss of use, disassembly, transportation, labor or damage to property on or near the product. Some states do not allow the exclusion or limitation of incidental or consequential damages, so the above limitation or exclusion may not apply to you.

d. This Warranty applies only to warranted defects that first arise and are transferred to subsequent owners or users of the product, and it shall be immediately void in the event the product is resold, transferred, leased or rented to any third party or person other than the original purchaser.

e. THERE ARE NO OTHER WARRANTIES APPLICABLE TO THIS PRODUCT. Under the laws of certain states, there may be no implied warranties from Boahaus and all implied warranties, INCLUDING ANY IMPLIED WARRANTY OF MERCHANTABILITY OR FITNESS FOR A PARTICULAR PURPOSE are disclaimed where allowed by law. TO THE EXTENT ANY IMPLIED WARRANTIES ARE APPLICABLE, ANY IMPLIED WARRANTIES, INCLUDING ANY IMPLIED WARRANTY OF MERCHANTABILITY OR FITNESS FOR A PARTICULAR PURPOSE, ARE LIMITED IN DURATION TO THE DURATION OF THIS EXPRESS WARRANTY or the minimum period allowed by law, whichever is shorter. Some states do not allow limitations on how long an implied Warranty lasts, so the above limitation may not apply to you.

f. For Warranty inquiries, questions about disposition or claims, please visit our website www.boahaus.com. You can also contact Boahaus at +1 281-809-4043 or email at administracion@boahaus.com. Boahaus may require Warranty claims to be submitted in writing to:

Boahaus LLC.
1250-1252
Ave. Franklin Delano Roosevelt,
San Juan, PR 00926.

Garantía de Tocador con Espejo 1637 Boahaus**Garantía limitada de 6 meses**

1. Boahaus, LLC proporciona cobertura de garantía limitada al comprador original de este producto por un período de 6 meses a partir de la fecha de compra contra defectos en materiales o mano de obra de componentes de muebles de Boahaus. Como se especifica en esta Garantía, "defecto" significa imperfecciones en componentes que perjudican sustancialmente la utilidad del producto. Esta Garantía le otorga derechos legales específicos y también puede tener otros derechos que varían de un estado a otro.
2. No hay cobertura de garantía por defectos o condiciones que resulten del incumplimiento de las instrucciones del producto, o advertencias, uso indebido o abuso, daño intencional, incendio, inundación, alteración o modificación del producto o uso del producto de manera inconsistente con su uso previsto, o cualquier condición resultante de mantenimiento incorrecto o inadecuado, limpieza o cuidado. Tampoco hay cobertura de garantía para productos alquilados o cualquier producto comprado "usado" o "tal cual", en una venta de emergencia o de salida de la empresa, o de un liquidador.
3. Boahaus puede requerir una confirmación independiente del defecto reclamado y un comprobante de compra. Las piezas de repuesto estarán garantizadas durante el período restante de la garantía original. BOAHAUS NO TENDRÁ NINGUNA RESPONSABILIDAD POR CUALQUIER DAÑO INCIDENTAL y todos estos daños ESTÁN EXCLUIDOS DE ESTA GARANTÍA, tales como pérdida de uso, desmontaje, transporte, mano de obra o daños a la propiedad en o cerca del producto. Algunos estados no permiten la exclusión o limitación de daños incidentales o consecuentes, por lo que la limitación o exclusión anterior puede no aplicarse a usted.
4. Esta Garantía se aplica únicamente a los defectos garantizados que surgen y se informan a Boahaus dentro del período de cobertura de la garantía. La garantía no puede ser transferida a los propietarios o usuarios posteriores del producto, y será inmediatamente nula en caso de que el producto sea revendido, transferido, arrendado o alquilado a cualquier tercero o persona que no sea el comprador original.
5. NO HAY OTRAS GARANTÍAS APLICABLES A ESTE PRODUCTO. Bajo las leyes de ciertos estados, no puede haber garantías implícitas de Boahaus y todas las garantías implícitas, INCLUYENDO CUALQUIER GARANTÍA IMPLÍCITA DE COMERCIABILIDAD O ADECUACIÓN PARA UN PROPÓSITO EN PARTICULAR, están exoneradas cuando permitido por la ley. TODAS LAS GARANTÍAS IMPLÍCITAS SON APLICABLES, LAS GARANTÍAS IMPLÍCITAS, INCLUIDAS CUALQUIER GARANTÍA IMPLÍCITA DE COMERCIABILIDAD O ADECUACIÓN PARA UN PROPÓSITO PARTICULAR, ESTÁN LIMITADAS EN DURACIÓN A LA DURACIÓN DE ESTA GARANTÍA EXPRESA o el período mínimo permitido por la ley, cualquiera que sea más corto. Algunos estados no permiten limitaciones sobre la duración de una garantía implícita, por lo que es posible que la limitación anterior no se aplique a usted.
6. Para consultas sobre la garantía, preguntas sobre la disposición o reclamaciones, visite nuestro sitio web www.boahaus.com. También puede ponerse en contacto con Boahaus en +1 281-809-4043 o por correo electrónico en administracion@boahaus.com. Boahaus puede requerir que los reclamos de garantía sean presentados por escrito a:

Boahaus LLC.
1250-1252
Ave. Franklin Delano Roosevelt,
San Juan, PR 00926.

Incluya su recibo de compra u otra prueba de compra y una descripción específica del defecto del producto.