

BoaHaus

ASSEMBLY INSTRUCTIONS

INSTRUCCIONES DE ARMADO

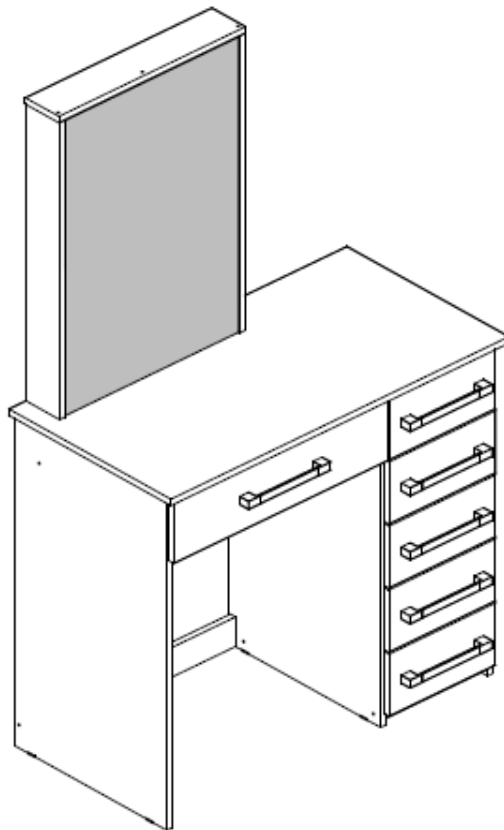

MODEL #: 1612

DRESSING TABLE WITH MIRROR

Tocador con espejo

Aprox. product weight 90.39 lbs. / 41 Kg. *

*Weight may vary +/- 5%

Lot: See package

Production date: See package

Purchase date: _____

THIS INFORMATION BOOKLET CONTAINS IMPORTANT SAFETY INFORMATION. PLEASE READ AND KEEP FOR FUTURE REFERENCE.
ESTE FOLLETO CONTIENE INFORMACIÓN DE SEGURIDAD IMPORTANTE. POR FAVOR, LEA Y GUÁRDELO PARA REFERENCIA FUTURA.

Need some Help? Call +1 (787) 688-1254 or email contact@boahaus.com
¿Necesitas ayuda? Llama +1 (787) 688-1254 o envía un email contact@boahaus.com

GENERAL SAFETY INFORMATION

1. Please read the Assembly Instructions prior to assembling this product.
2. Remove all the hardware from the box and sort by type.
3. Check to see that all the hardware and parts are present BEFORE assembling.
4. To avoid damage, assemble the product on a sturdy, level and protective surface.
5. Please wait until all steps are completed before fully tightening bolts.
6. Make sure all bolts are tightly fastened before the unit is used.
7. To move the product, you must lift it. DO NOT drag it, if you drag it can cause overturning.
8. **This product is sold with a hardware kit to be fixed on the wall. You must install this kit to prevent any accidents or damages. When properly installed, this restrain can provide protection against the unexpected tipping of the unit due to small tremors, bumps or climbing. The restrain is only a deterrent and is not a substitute for proper adult supervision. Use of tip-over restraints may only reduce, but not eliminate, the risk of tip-over**

INFORMACIÓN GENERAL DE SEGURIDAD

1. Lea las instrucciones de armado antes de ensamblar este producto.
2. Extraiga todo el hardware de la caja y ordene por tipo.
3. Verifique que todo el hardware y las piezas están presentes ANTES de ensamblar.
4. Para evitar daños, ensamble el producto sobre una superficie resistente, nivelada y con protección.
5. Espere hasta que todos los pasos se hayan completado antes de apretar completamente los tornillos y accesorios.
6. Asegúrese de que todos los tornillos y accesorios estén bien apretados antes de usar la unidad.
7. Para mover el producto debe levantarlo. NO lo arrastre, si lo arrastra puede causar volcamiento.
8. **Este producto se vende con un kit de accesorios para ser fijado en la pared. Debe instalar este kit para evitar accidentes o daños. Cuando se instala correctamente, esta restricción puede proporcionar protección contra la inclinación inesperada de la unidad debido a temblores pequeños, golpes o al treparse. La restricción es solo un elemento disuasivo y no es un sustituto de la supervisión adecuada de un adulto. El uso de restricciones de vuelco solo puede reducir, pero no eliminar, el riesgo de volcarse.**

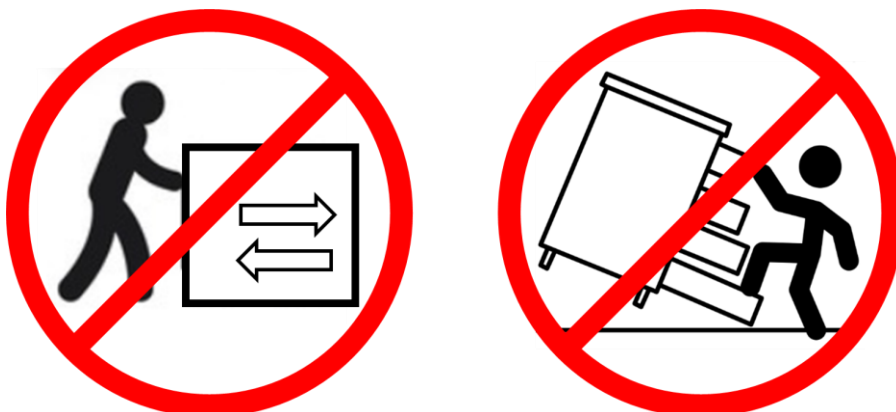

General Dimensions / Dimensiones Generales

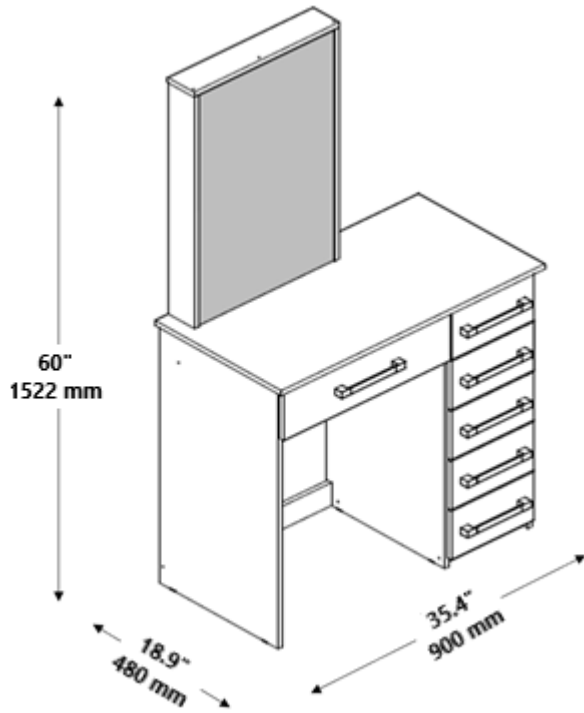

Maximum weight supported Peso máximo soportado

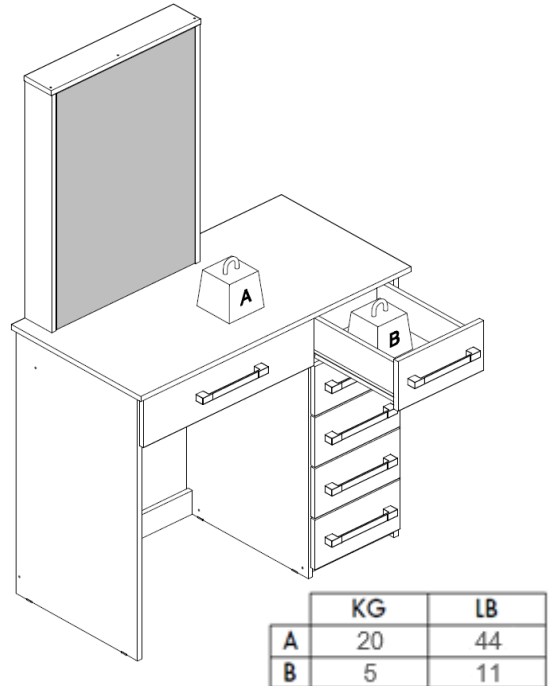

Note: weight must be evenly distributed.
Nota: el peso debe estar distribuido uniformemente.

You will need / usted necesitará:

Tools not included / herramientas no incluidas



2 people
2 personas

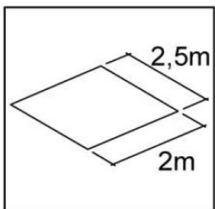

Recommended space for assembly
Espacio recomendado para el armado

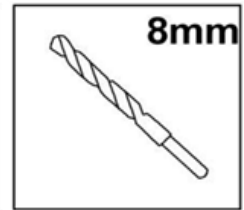
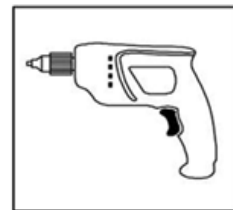
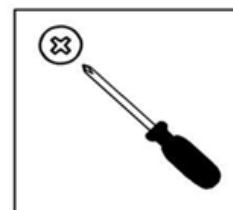

Note: Place a carpet or blanket in the assembly area to avoid damage to the parts during the process.
Nota: Colocar una alfombra o manta en el area de armado para evitar daños en las piezas durante el proceso.

The drill will be used ONLY to fix the furniture to the wall.
El taladro será usado SOLO para fijar el mueble a la pared.

PARTS IDENTIFICATION / IDENTIFICACION DE PARTES



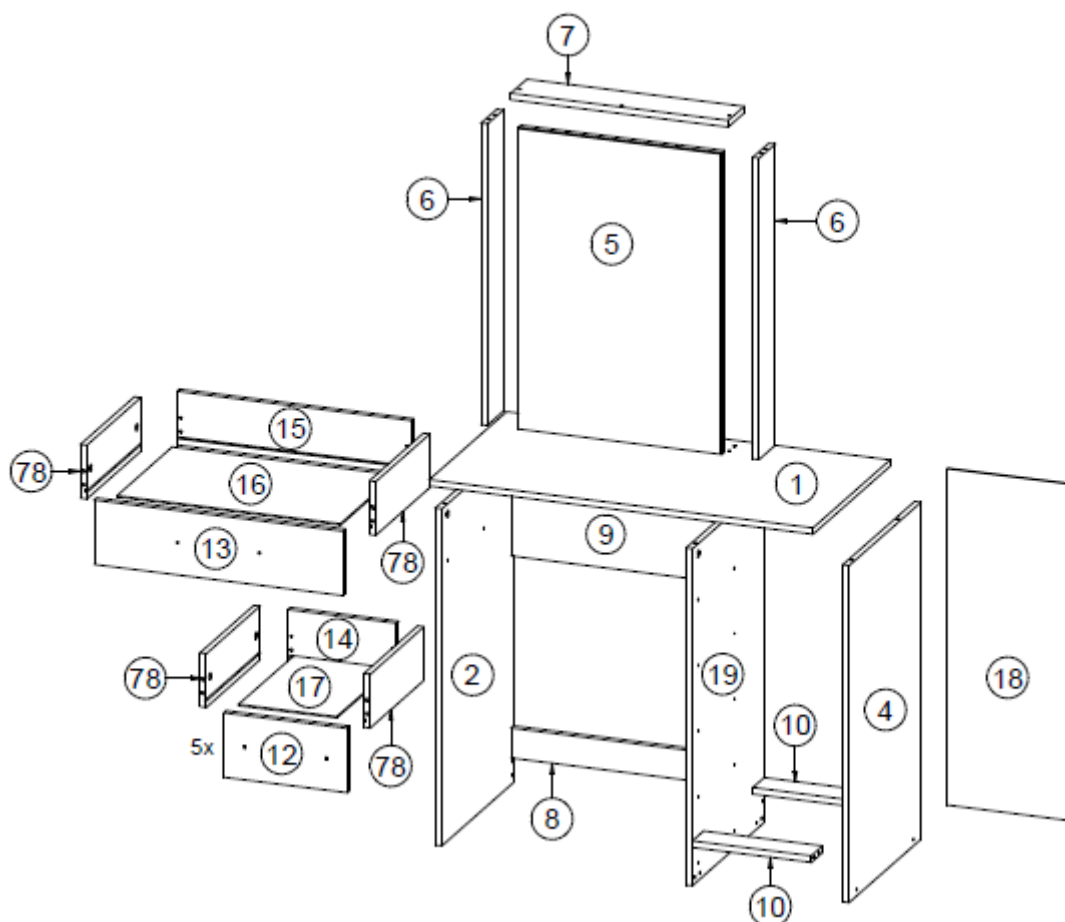







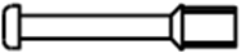

Nº	DESCRIPTION - DESCRIPCIÓN	QTY.
1	Top base / Base superior	1
2	Left side / Lateral izquierdo	1
4	Right side / Lateral derecho	1
5	Mirror / Espejo	1
6	Side tray / Travesaño lateral	2
7	Top tray / Travesaño superior	1
8	Large footer / Zócalo grande	1
9	Back panel / Panel trasero	1
10	Small footer / Zócalo pequeño	2
12	Front of small drawer / Frontal de cajón pequeño	5
13	Front of large drawer / Frontal de cajón grande	1
14	Rear of small drawer / Posterior de cajón pequeño	5
15	Rear of large drawer / Posterior de cajón grande	1
16	Bottom of large drawer / Fondo de cajón grande	1
17	Bottom of small drawer / Fondo de cajón pequeño	5
18	Backboard / Fondo	1
19	Division / División	1
78	Side of drawer / Lateral de cajón	12





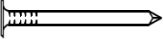

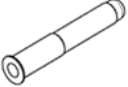
IDENTIFICATION OF ACCESSORIES / IDENTIFICACION DE ACCESORIOS

Note: the separation of the accessories before starting the assembly will facilitate it. The screws are in real scale. In case of doubt, place the screw on the image.

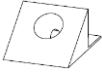
Nota: la separación de los accesorios antes de empezar el armado facilitará el mismo. Los tornillos están a escala real. En caso de dudas coloque el tornillo sobre la imagen.

CODE		DESCRIPTION	QTY
A		Wooden dowel / Pin	42
B		Simple minifix screw / Tornillo minifix simple	30
C		Drum lock / Tambor minifix	30
CR1		Metallic left slide / Corredera lateral izquierda	6
CR2		Metallic right slide / Corredera lateral derecha	6
CR3		Left drawer slide / Corredera de cajón izquierda	6
CR4		Right drawer slide / Corredera de cajón derecha	6
D		Flat head screw / Tornillo cabeza plana 3.5 x 14 mm	56
DE		Flanged head screw / Tornillo cabeza flangeada (5 x 50 mm)	1
E		Flat head screw / Tornillo cabeza plana 3.5 x 40 mm	15
EN		Nail / Clavo	29
I		Flat head screw / Tornillo cabeza plana 3.5 x 30 mm	12
L		Bushing / Tapón	1
P		Flat head screw / Tornillo cabeza plana 6 x 8 mm	4

PX		Handle / Manilla	6
U		Triangle support / Soporte triangular	2
V		Metallic angle plate / Soporte de metal	1
X		Small plastic foot / Pie plástico	7
Y		Bore adhesive patch / Tapones adhesivos	15

PRE-ASSEMBLY / PRE- ARMADO

1. Fix **wooden dowel (A)** and **small plastic foot (X)** to **large footer (8)**.
Fijar **pin (A)** y **pie plástico (X)** a **zócalo grande (8)**.

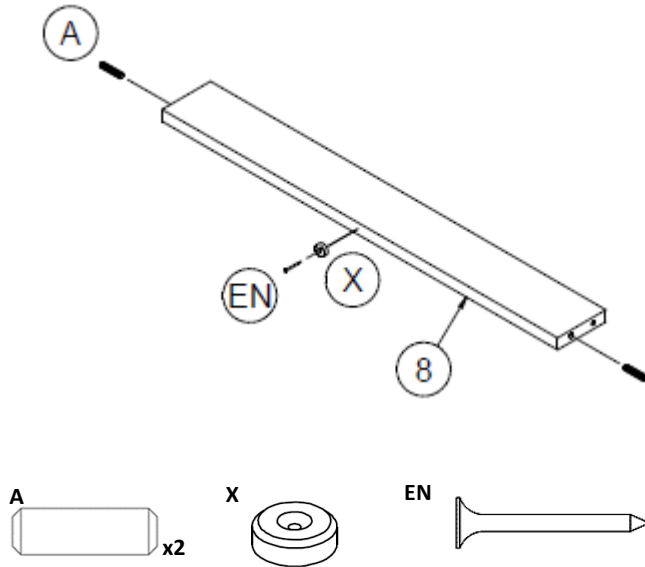

2. Fix **wooden dowel (A)** to **side tray (6) x2**, **back panel (9)** and **small footer (10) x2**.
Fijar **pin (A)** a **travesaño lateral (6) x2**, **panel trasero (9)** y **zócalo pequeño (10) x2**.

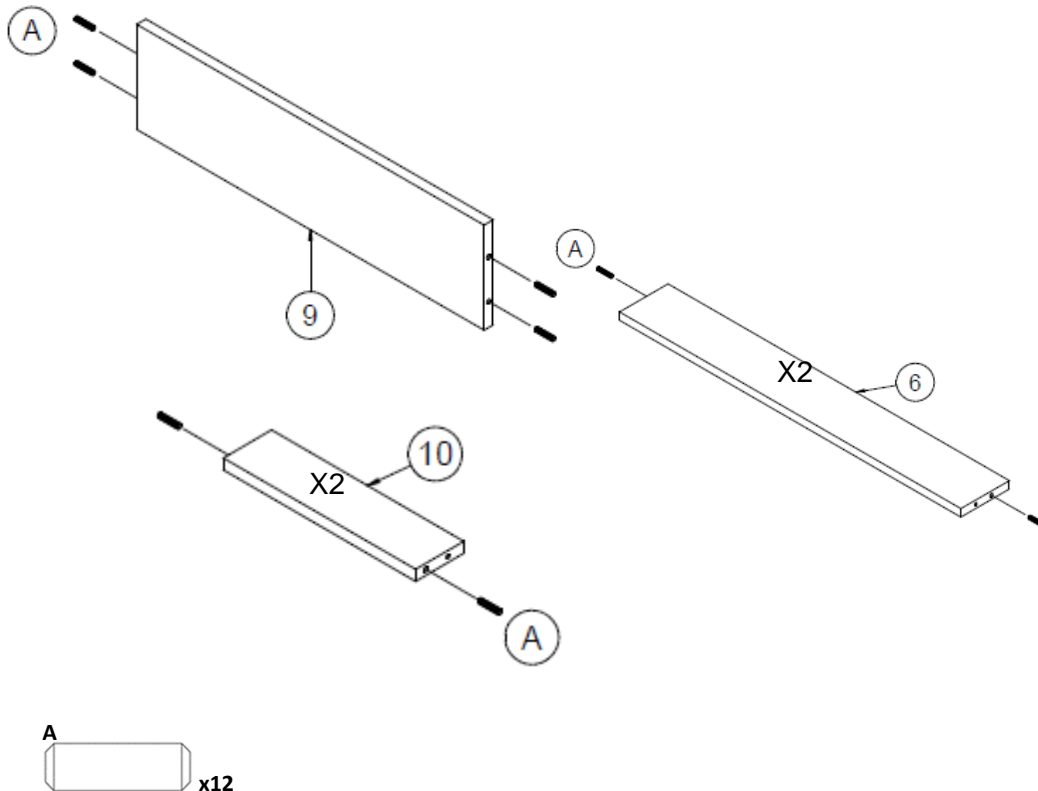

- Fix **wooden dowel** (A) to **mirror** (5).
Fijar **pin** (A) a **espejo** (5).

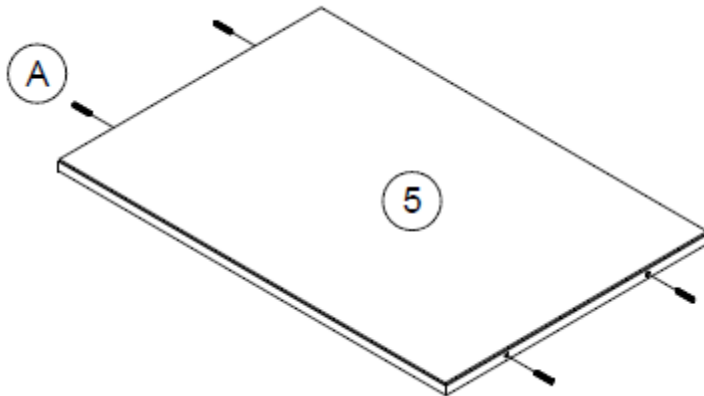

- Fix **small plastic foot** (X) and **metallic left slide** (CR1) to **left side** (2).
Fijar **pie plástico** (X) y **corredera lateral izquierda** (CR1) a **lateral izquierdo** (2).

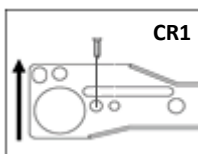
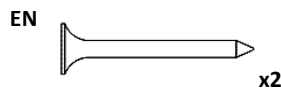
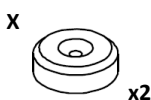
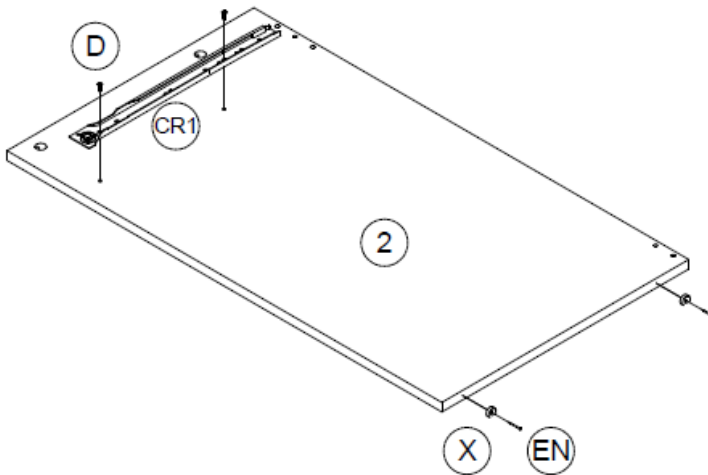

Note: the two upper holes have to be facing up.
Nota: los dos agujeros superiores deben estar hacia arriba.

5. Fix **small plastic foot** (X) and **metallic right slide** (CR2) to **right side** (4).
 Fijar **pie plástico** (X) y **corredera lateral derecha** (CR2) a **lateral derecho** (4).

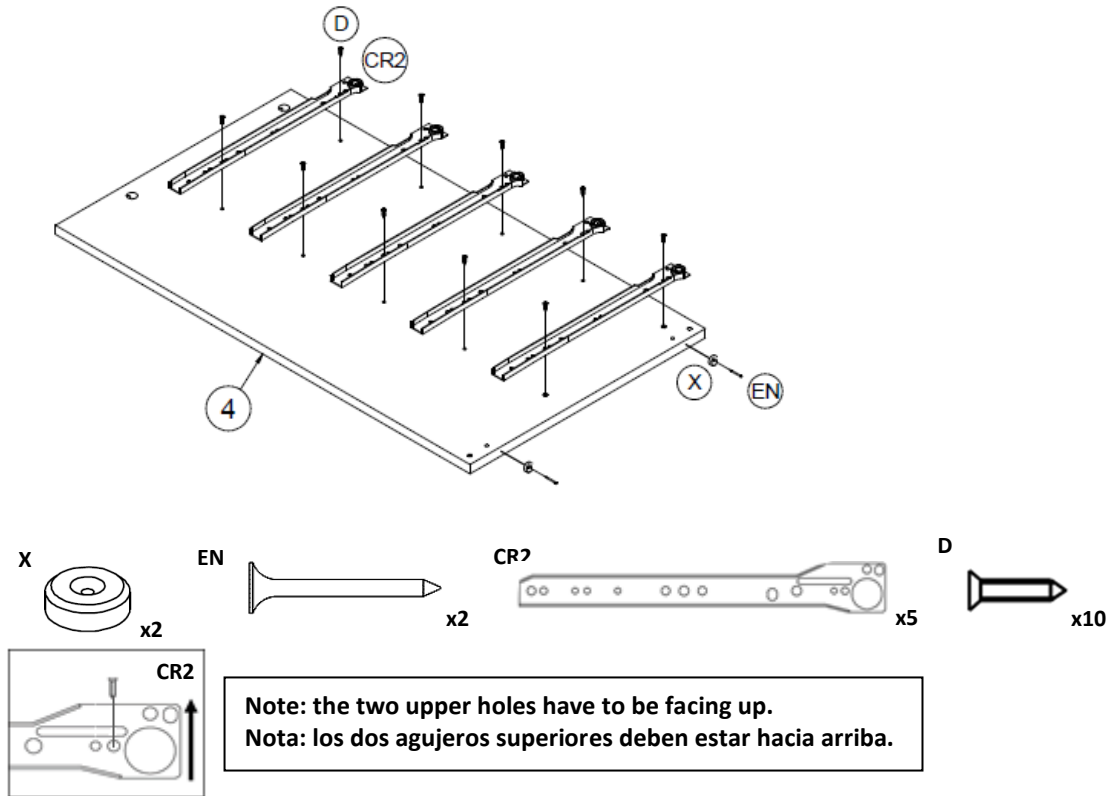

6. Fix **metallic right slide** (CR2) and **small plastic foot** (X) to **division** (19).
 Fijar **corredera lateral derecha** (CR2) y **pie plástico** (X) a **división** (19).

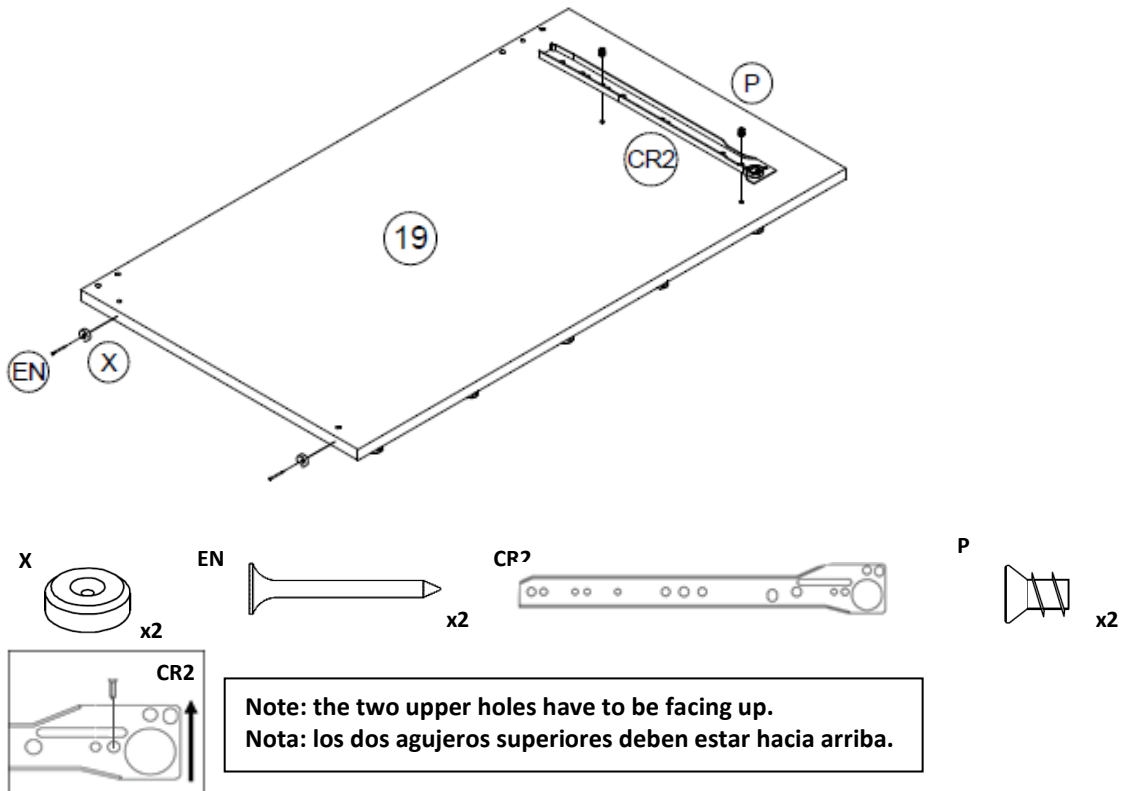

7. Flip and fix **metallic left slide** (CR1) to **division** (19).
 Voltrear y fijar **corredera lateral izquierda** (CR1) a **división** (19).

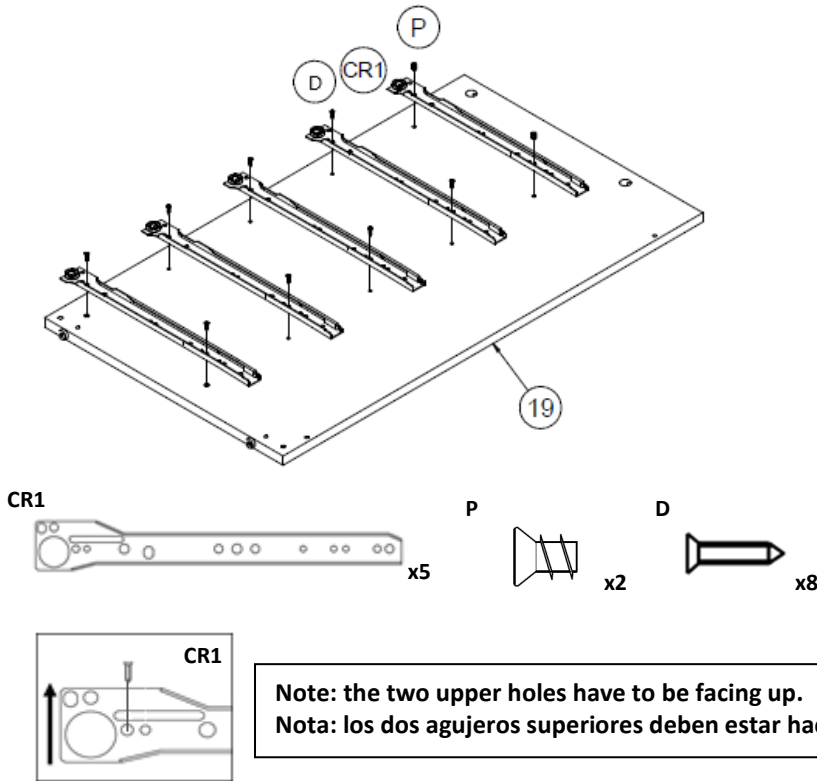

8. Fix **simple minifix screw** (B) and **metallic bracket** (V) to **top base** (1).
 Fijar **ornillo minifix simple** (B) y **soporte de metal** (V) a **base superior** (1).

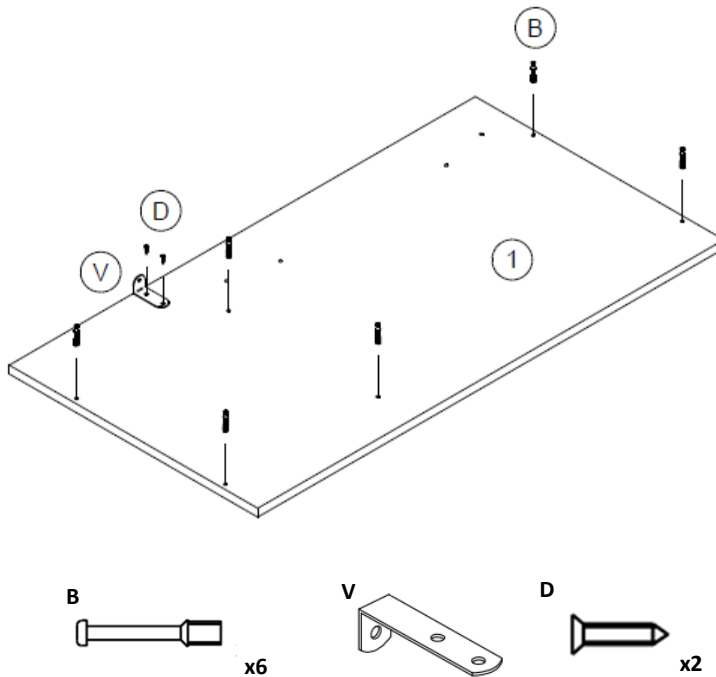

9. Fix *simple minifix screw* (B) to *front of small drawer* (14) x5 and *front of large drawer* (15).
Fijar *tornillo minifix simple* (B) a *frente de cajón pequeño* (14) x5 y *frente de cajón grande* (15).

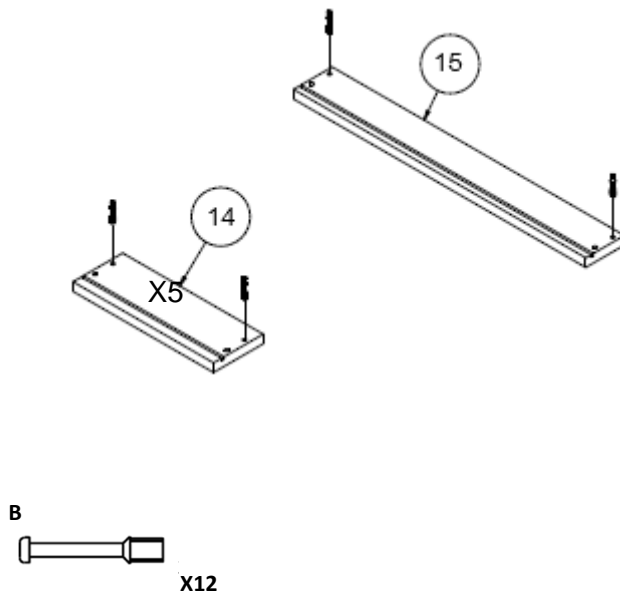

10. Fix *simple minifix screw* (B) to *rear of small drawer* (12) x5 and *rear of large drawer* (13).
Fijar *tornillo minifix simple* (B) a *posterior de cajón pequeño* (12) x5 y *posterior de cajón grande* (13).

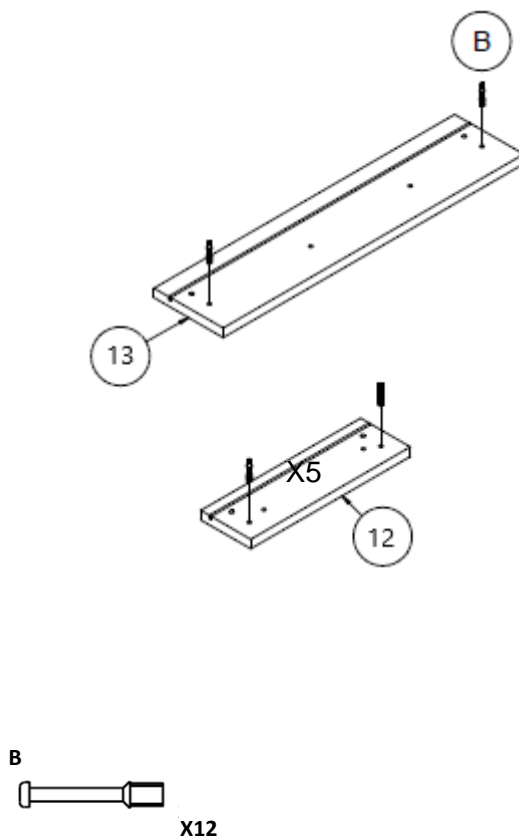

11. Fix **wooden dowel** (A) to **side of drawer** (78) x12.
Fijar **pin** (A) a **lateral de cajón** (78) x12.

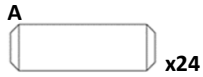
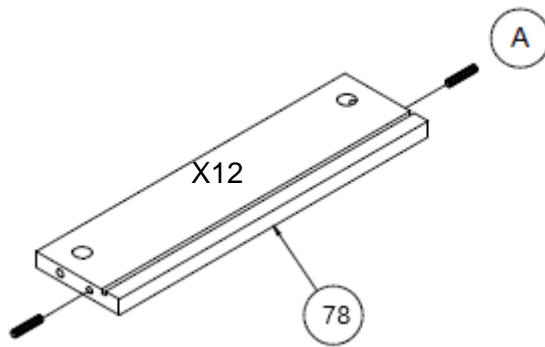

ASSEMBLY / ARMADO

12. Fix **side tray** (6) x2 and **mirror** (5) to **top tray** (7).

Fijar **travesaño lateral** (6) x2 y **espejo** (5) a **travesaño superior** (7).

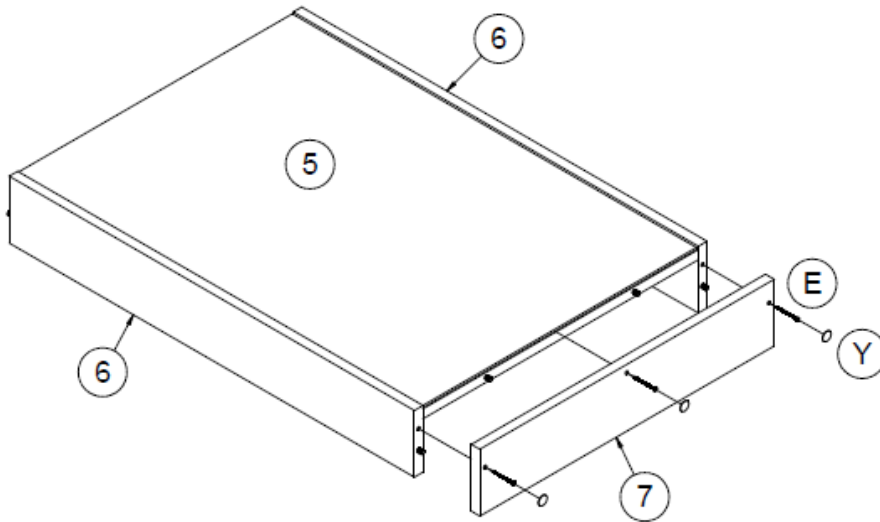

13. Fix **top base** (1) to previous assembly.

Fijar **base superior** (1) a ensamble previo.

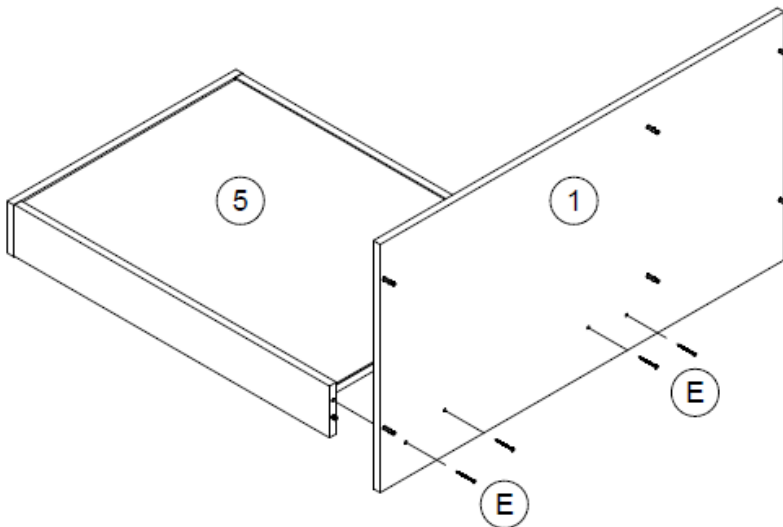

14. Fix **small footer** (10) x2 and **division** (19) to **right side** (4).
 Fijar **zócalo pequeño** (10) x2 y **división** (19) a **lateral derecho** (4).

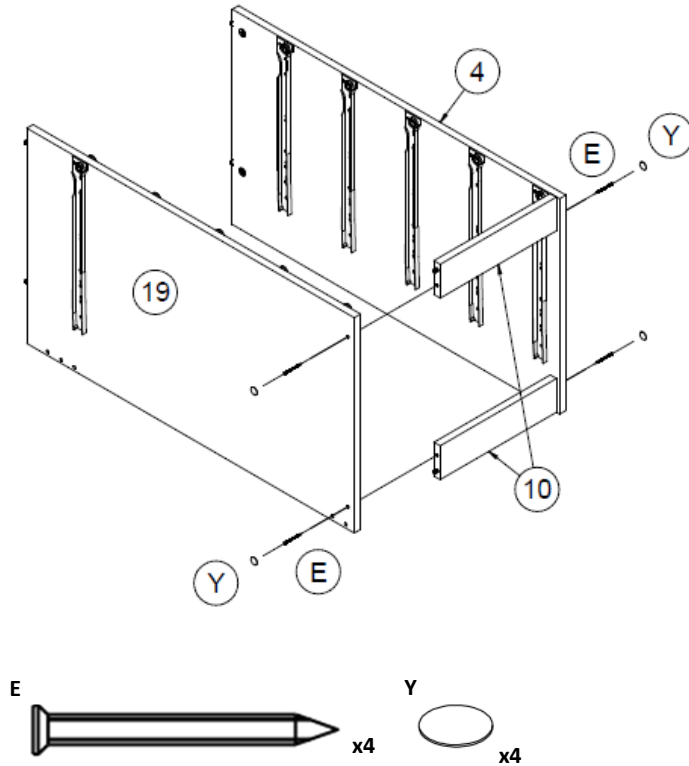

15. Fix **large footer** (8), **back panel** (9) and **left side** (2) to previous assembly.
 Fijar **zócalo grande** (8), **panel trasero** (9) y **lateral izquierdo** (2) a ensamble previo.

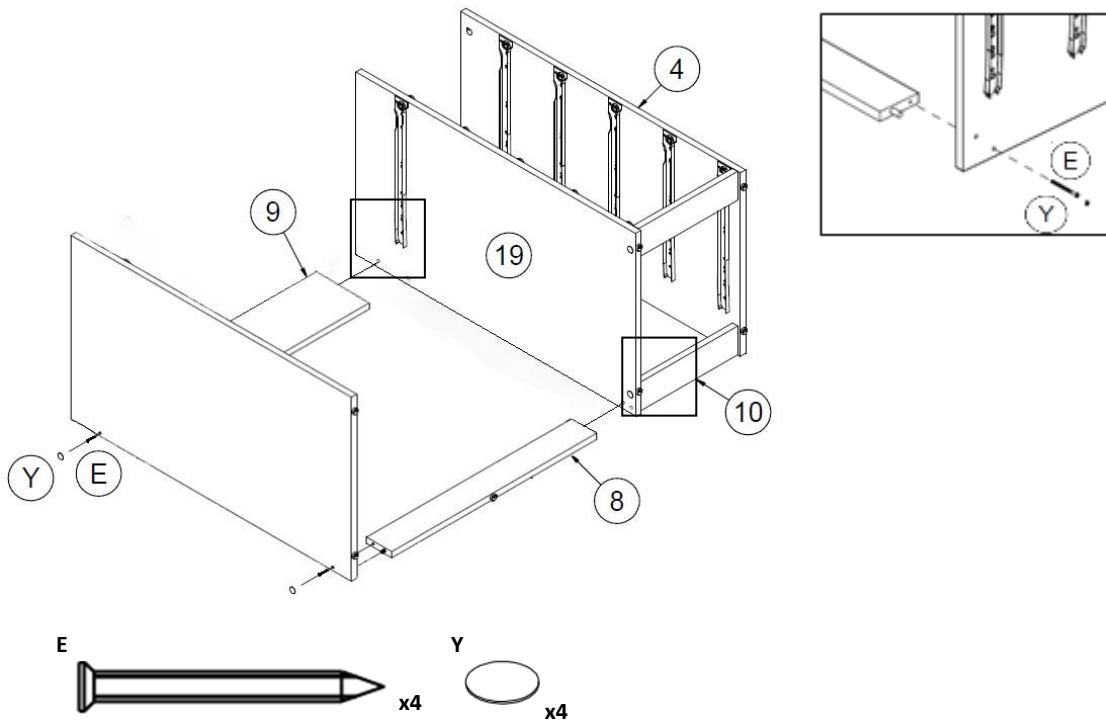

16. Fix both previous assemblies (13 and 15).
 Fijar ambos ensambles previos (13 y 15).

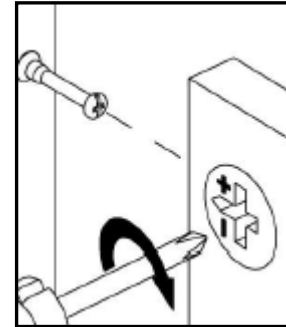
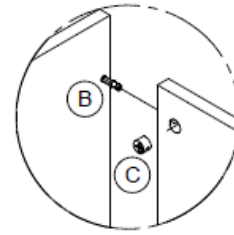
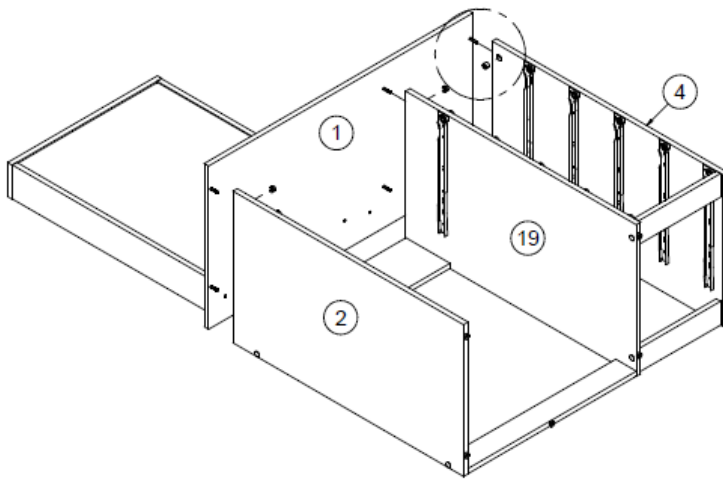

17. Fix **backboard** (18) to previous assemble.
 Fijar **fondo** (18) a ensamble previo.

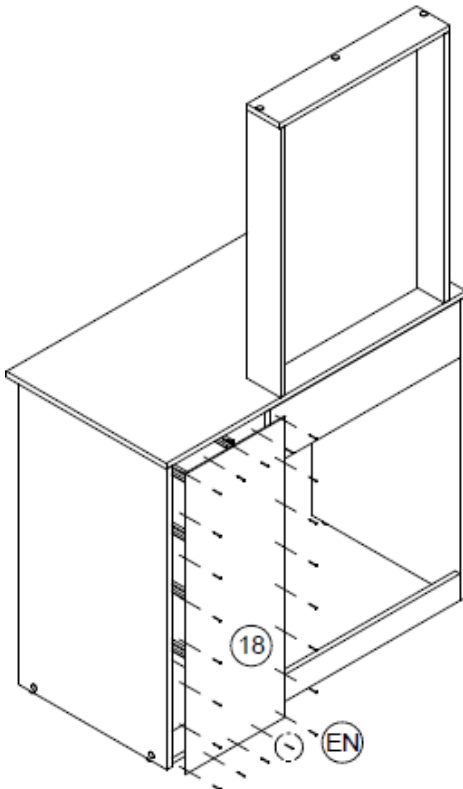

18. Fix *side of top drawer* (78) x2 and *large of bottom drawer* (16) to *rear of large drawer* (15).
 Fijar *lateral de cajón* (78) x2 y *fondo de cajón grande* (16) a *posterior de cajón grande* (15).

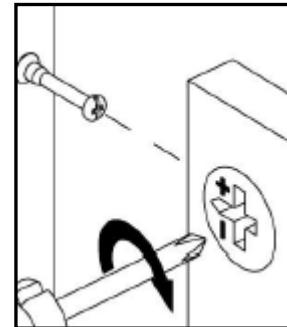
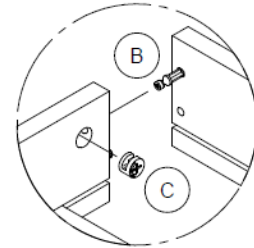
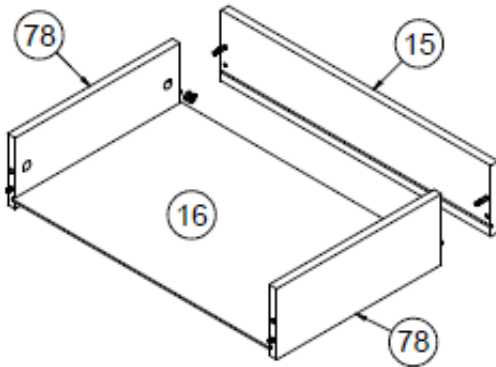

19. Fix *front of large drawer* (13) to previous assembly.
 Fijar *frente de cajón grande* (13) a ensamble previo.

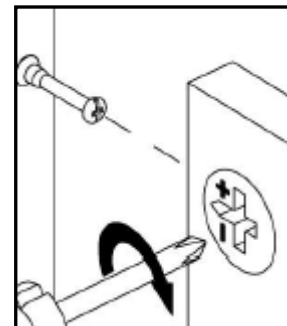
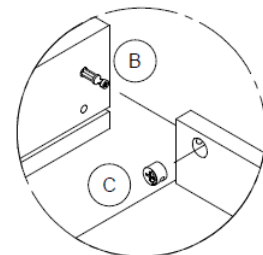
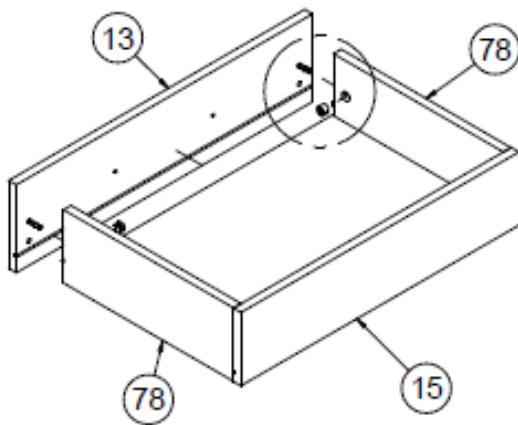

20. Fix *side of top drawer* (78) x10 and *small of bottom drawer* (14) x5 to *rear of small drawer* (17) x5.
 Fijar *lateral de cajón* (78) x10 y *fondo de cajón pequeño* (14) x5 a *posterior de cajón pequeño* (17) x5.

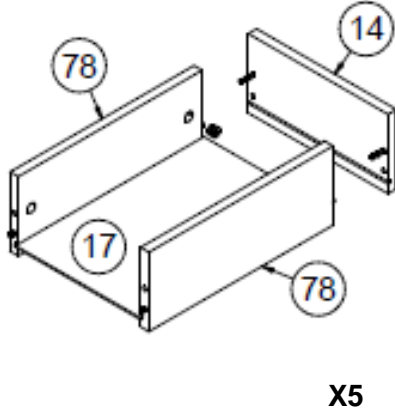

X5

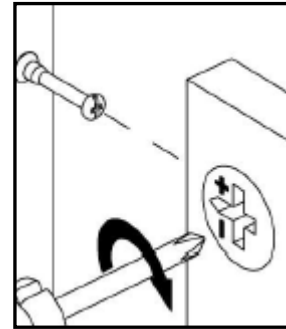
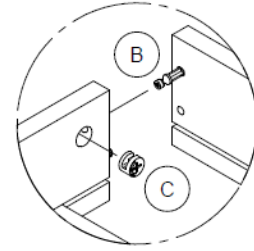

21. Fix *front of small drawer* (12) to previous assembly.
 Fijar *frente de cajón pequeño* (12) a ensamble previo.

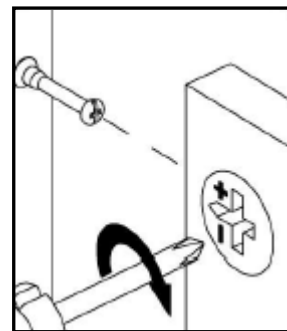
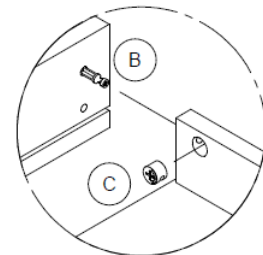
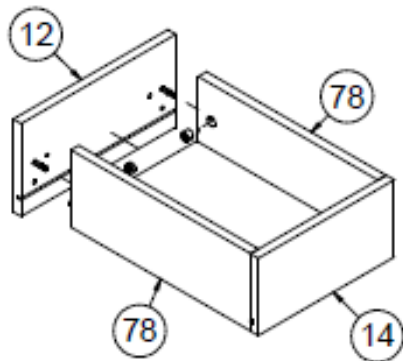

22. Fix **handle** (PX) to previous assemblies (19 and 21).
 Fijar **tirador** (PX) a ensambles previos (19 y 21).

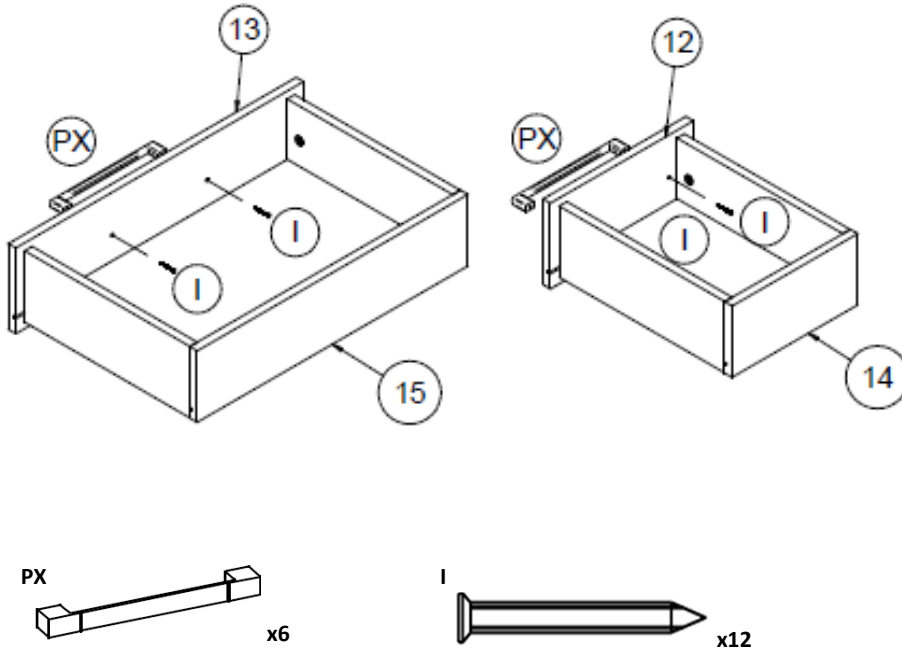

23. Fix **left drawer slide** (CR3) and **right drawer slide** (CR4) to drawer x6.
 Fijar **corredera de cajón izquierda** (CR3) y **corredera de cajón derecha** (CR4) a cajón x6.

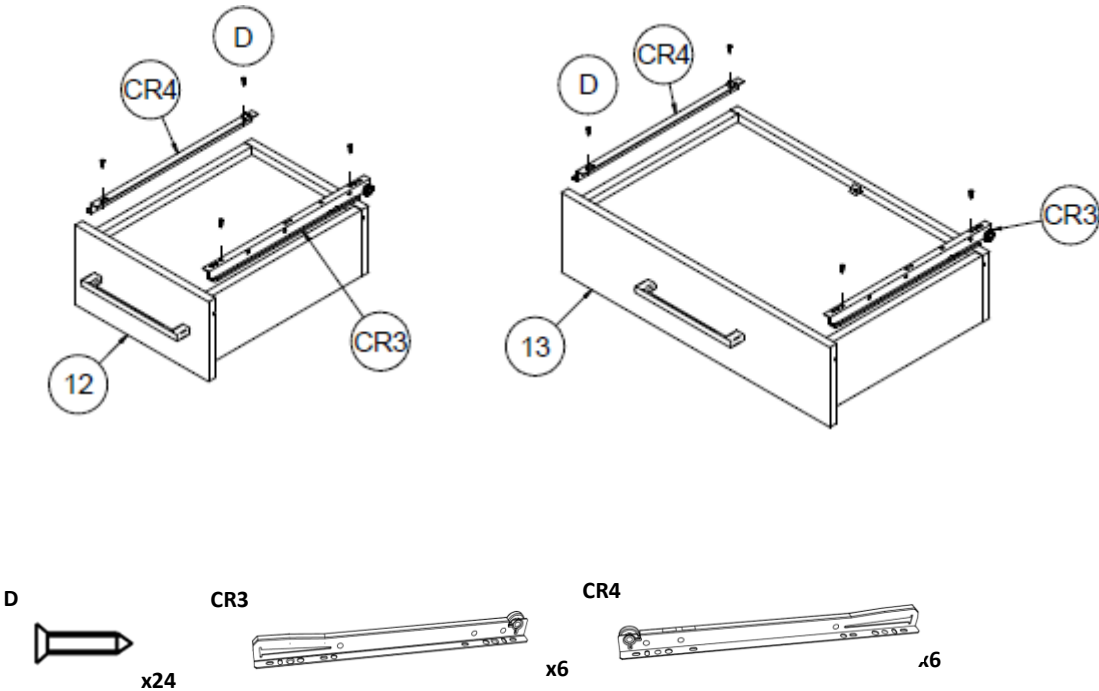

24. Fix furniture to the wall.
Fijar el mueble a la pared.

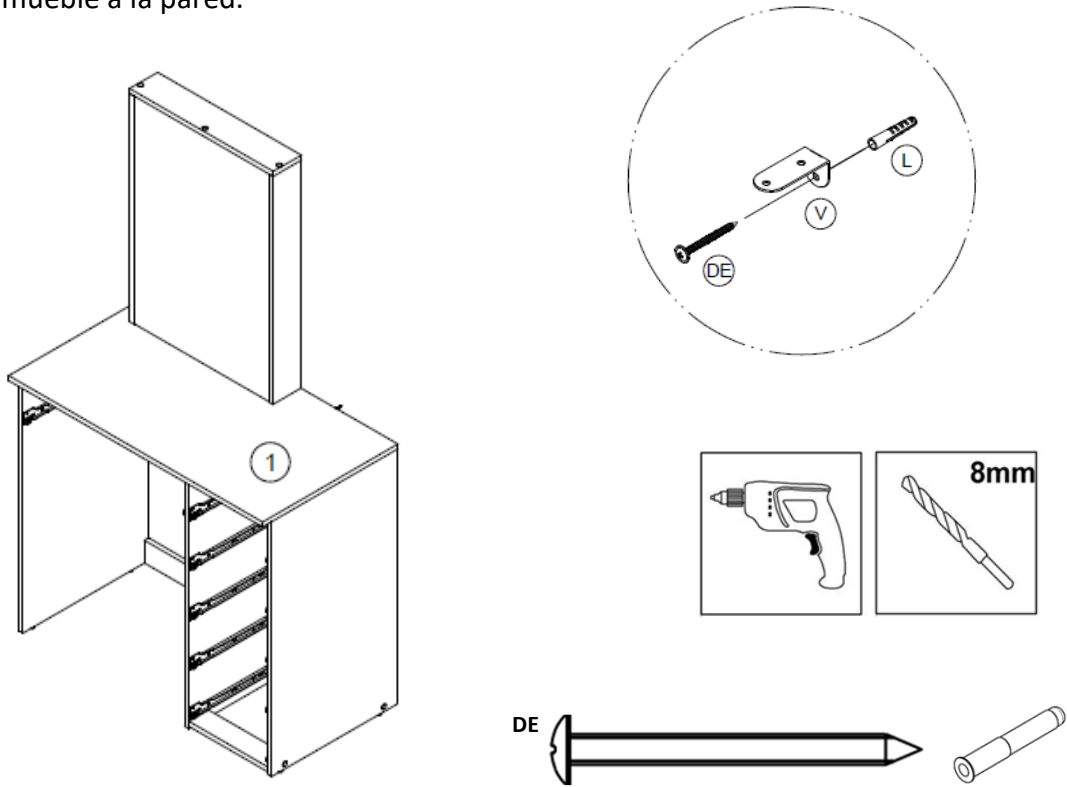

WARNING.
For security measures it is recommended to fix the furniture to the wall to avoid overturning of it, if this happens it can cause serious or fatal injuries.

ATENCIÓN.
Por medidas de seguridad se recomienda fijar el mueble a la pared para evitar volcamiento del mismo, si esto llegase a ocurrir puede causar lesiones graves o fatales.

25. And finally place drawers on the furniture.
Y finalmente colocar cajones en el mueble.

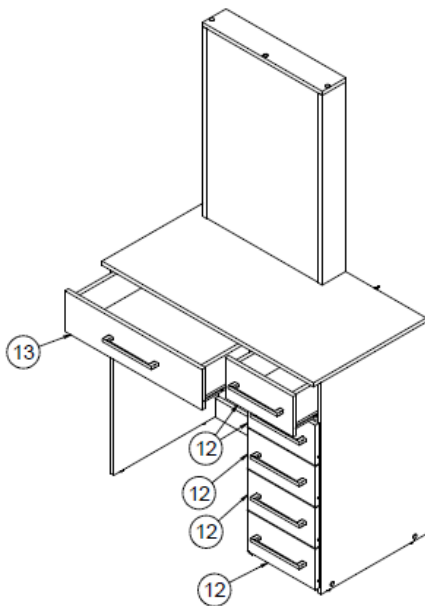

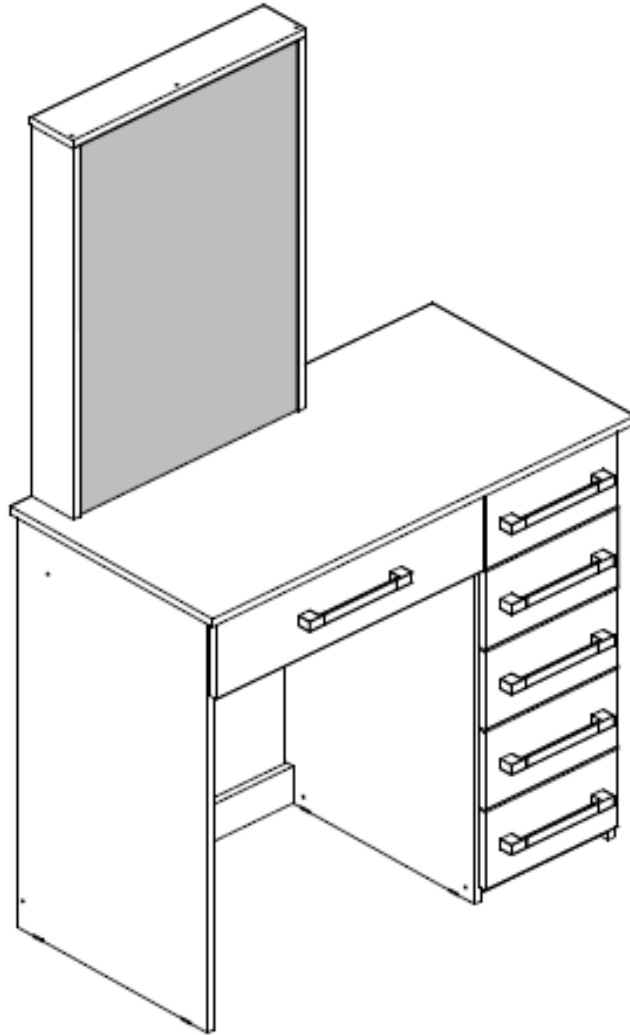

***Congratulations, you have assembled your TABLE WITH MIRROR!!!
¡¡¡Felicitaciones, has armado tu Tocador con Espejo!!!***

1612 Boahaus Dressing Table with Mirror Warranty**6-Months Limited Warranty**

1. Boahaus, LLC provides limited warranty coverage to the original purchaser of this product for a period of six months from the date of purchase against defects in materials or workmanship of Boahaus furniture components. As used in this Warranty, “defect” means imperfections in components which substantially impair the utility of the product. This Warranty gives you specific legal rights, and you may also have other rights which vary from state to state.
2. There is no warranty coverage for defects or conditions that result from the failure to follow product assembly instructions, information or warnings, misuse or abuse, intentional damage, fire, flood, alteration or modification of the product, or use of the product in a manner inconsistent with its intended use, nor any condition resulting from incorrect or inadequate maintenance, cleaning, or care. There is also no warranty coverage for rented products or any products purchased “used” or “as is”, at a distress or going-out-of business sale, or from a liquidator.
3. As the exclusive remedy under this Warranty, Boahaus will (at its sole option) repair, replace or refund the value of any defective furniture component. Boahaus may require independent confirmation of the claimed defect and proof of purchase. Replacement parts will be warranted for only the remaining period of the original Warranty. BOAHAUS SHALL HAVE NO LIABILITY for ANY INCIDENTAL OR CONSEQUENTIAL DAMAGES OF ANY KIND and all such damages are EXCLUDED FROM THIS WARRANTY, such as loss of use, disassembly, transportation, labor or damage to property on or near the product. Some states do not allow the exclusion or limitation of incidental or consequential damages, so the above limitation or exclusion may not apply to you.
4. This Warranty applies only to warranted defects that first arise and are transferred to subsequent owners or users of the product, and it shall be immediately void in the event the product is resold, transferred, leased or rented to any third party or person other than the original purchaser.
5. THERE ARE NO OTHER WARRANTIES APPLICABLE TO THIS PRODUCT. Under the laws of certain states, there may be no implied warranties from Boahaus and all implied warranties, INCLUDING ANY IMPLIED WARRANTY OF MERCHANTABILITY OR FITNESS FOR A PARTICULAR PURPOSE are disclaimed where allowed by law. TO THE EXTENT ANY IMPLIED WARRANTIES ARE APPLICABLE, ANY IMPLIED WARRANTIES, INCLUDING ANY IMPLIED WARRANTY OF MERCHANTABILITY OR FITNESS FOR A PARTICULAR PURPOSE, ARE LIMITED IN DURATION TO THE DURATION OF THIS EXPRESS WARRANTY or the minimum period allowed by law, whichever is shorter. Some states do not allow limitations on how long an implied Warranty lasts, so the above limitation may not apply to you.
6. For Warranty inquiries, questions about disposition or claims, please visit our website www.boahaus.com. You can also contact Boahaus at +1 (787) 688-1254 or email at administracion@boahaus.com. Boahaus may require Warranty claims to be submitted in writing to:

Boahaus, LLC.

Plaza Del Palmar, 511

Guaynabo, Puerto Rico 00969

Please include your sales receipt or other proof of purchase and a specific description of the product defect.

Garantía de Tocador con Espejo 1612 Boahaus**Garantía limitada de 6 meses**

1. Boahaus, LLC proporciona cobertura de garantía limitada al comprador original de este producto por un período de 6 meses a partir de la fecha de compra contra defectos en materiales o mano de obra de componentes de muebles de Boahaus. Como se especifica en esta Garantía, "defecto" significa imperfecciones en componentes que perjudican sustancialmente la utilidad del producto. Esta Garantía le otorga derechos legales específicos y también puede tener otros derechos que varían de un estado a otro.
2. No hay cobertura de garantía por defectos o condiciones que resulten del incumplimiento de las instrucciones del producto, o advertencias, uso indebido o abuso, daño intencional, incendio, inundación, alteración o modificación del producto o uso del producto de manera inconsistente con su uso previsto, o cualquier condición resultante de mantenimiento incorrecto o inadecuado, limpieza o cuidado. Tampoco hay cobertura de garantía para productos alquilados o cualquier producto comprado "usado" o "tal cual", en una venta de emergencia o de salida de la empresa, o de un liquidador.
3. Boahaus puede requerir una confirmación independiente del defecto reclamado y un comprobante de compra. Las piezas de repuesto estarán garantizadas durante el período restante de la garantía original. BOAHAUS NO TENDRÁ NINGUNA RESPONSABILIDAD POR CUALQUIER DAÑO INCIDENTAL y todos estos daños ESTÁN EXCLUIDOS DE ESTA GARANTÍA, tales como pérdida de uso, desmontaje, transporte, mano de obra o daños a la propiedad en o cerca del producto. Algunos estados no permiten la exclusión o limitación de daños incidentales o consecuentes, por lo que la limitación o exclusión anterior puede no aplicarse a usted.
4. Esta Garantía se aplica únicamente a los defectos garantizados que surgen y se informan a Boahaus dentro del período de cobertura de la garantía. La garantía no puede ser transferida a los propietarios o usuarios posteriores del producto, y será inmediatamente nula en caso de que el producto sea revendido, transferido, arrendado o alquilado a cualquier tercero o persona que no sea el comprador original.
5. NO HAY OTRAS GARANTÍAS APLICABLES A ESTE PRODUCTO. Bajo las leyes de ciertos estados, no puede haber garantías implícitas de Boahaus y todas las garantías implícitas, INCLUYENDO CUALQUIER GARANTÍA IMPLÍCITA DE COMERCIABILIDAD O ADECUACIÓN PARA UN PROPÓSITO EN PARTICULAR, están exoneradas cuando permitido por la ley. TODAS LAS GARANTÍAS IMPLÍCITAS SON APLICABLES, LAS GARANTÍAS IMPLÍCITAS, INCLUIDAS CUALQUIER GARANTÍA IMPLÍCITA DE COMERCIABILIDAD O ADECUACIÓN PARA UN PROPÓSITO PARTICULAR, ESTÁN LIMITADAS EN DURACIÓN A LA DURACIÓN DE ESTA GARANTÍA EXPRESA o el período mínimo permitido por la ley, cualquiera que sea más corto. Algunos estados no permiten limitaciones sobre la duración de una garantía implícita, por lo que es posible que la limitación anterior no se aplique a usted.
6. Para consultas sobre la garantía, preguntas sobre la disposición o reclamaciones, visite nuestro sitio web www.boahaus.com. También puede ponerse en contacto con Boahaus en +1 (787) 688-1254 o por correo electrónico en administracion@boahaus.com. Boahaus puede requerir que los reclamos de garantía sean presentados por escrito a:

Boahaus, LLC.
Plaza Del Palmar, 511
Guaynabo, Puerto Rico 00969

Incluya su recibo de compra u otra prueba de compra y una descripción específica del defecto del producto.