

BoatHaus

ASSEMBLY INSTRUCTIONS

ATTENTION!!!

Any inquiry or replacement parts
you need, contact us directly at:

contact@boahaus.com

Scan this QR Code to chat to Customer Support Team.



Or Call Us at +1 (787) 688-1254

BoaHaus

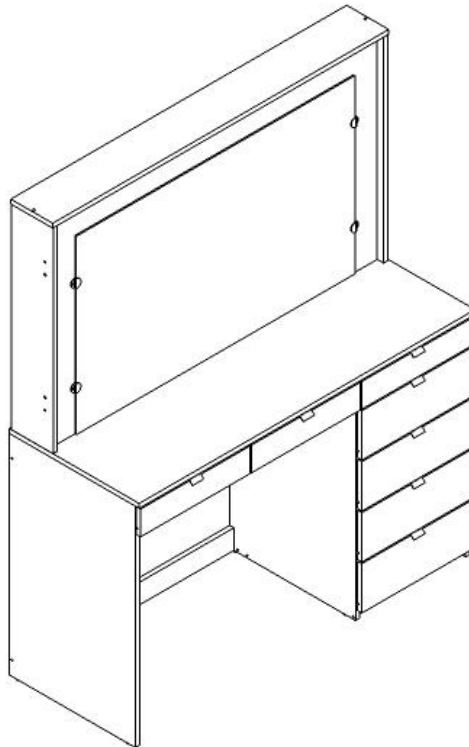
ASSEMBLY INSTRUCTIONS**INSTRUCCIONES DE ARMADO****MODEL #: 1609****DRESSING TABLE WITH MIRROR****Tocador con Espejo****Aprox. product weight 105.02 lbs. / 47,71 Kg. ******Weight may vary +/- 5%.****Lot: See package****Production date: See package****Purchase date: _____**

THIS INFORMATION BOOKLET CONTAINS IMPORTANT SAFETY INFORMATION. PLEASE READ AND KEEP FOR FUTURE REFERENCE.
ESTE FOLLETO CONTIENE INFORMACIÓN DE SEGURIDAD IMPORTANTE. POR FAVOR, LEA Y GUÁRDELO PARA REFERENCIA FUTURA.

Need some Help? Call +1 (787) 688-1254 or email contact@boahaus.com
¿Necesitas ayuda? Llama +1 (787) 688-1254 o envía un email contact@boahaus.com

GENERAL SAFETY INFORMATION

1. Please read the Assembly Instructions prior to assembling this product.
2. Remove all the hardware from the box and sort by type.
3. Check to see that all the hardware and parts are present BEFORE assembling.
4. To avoid damage, assemble the product on a sturdy, level and protective surface.
5. Please wait until all steps are completed before fully tightening bolts.
6. Make sure all bolts are tightly fastened before the unit is used.
7. To move the product, you must lift it. DO NOT drag it, if you drag it can cause overturning.
8. **This product is sold with a hardware kit to be fixed on the wall. You must install this kit to prevent any accidents or damages. When properly installed, this restrain can provide protection against the unexpected tipping of the unit due to small tremors, bumps or climbing. The restrain is only a deterrent and is not a substitute for proper adult supervision. Use of tip-over restraints may only reduce, but not eliminate, the risk of tip-over**

INFORMACIÓN GENERAL DE SEGURIDAD

1. Lea las instrucciones de armado antes de ensamblar este producto.
2. Extraiga todo el hardware de la caja y ordene por tipo.
3. Verifique que todo el hardware y las piezas están presentes ANTES de ensamblar.
4. Para evitar daños, ensamble el producto sobre una superficie resistente, nivelada y con protección.
5. Espere hasta que todos los pasos se hayan completado antes de apretar completamente los tornillos y accesorios.
6. Asegúrese de que todos los tornillos y accesorios estén bien apretados antes de usar la unidad.
7. Para mover el producto debe levantarlo. NO lo arrastre, si lo arrastra puede causar volcamiento.
8. **Este producto se vende con un kit de accesorios para ser fijado en la pared. Debe instalar este kit para evitar accidentes o daños. Cuando se instala correctamente, esta restricción puede proporcionar protección contra la inclinación inesperada de la unidad debido a temblores pequeños, golpes o al treparse. La restricción es solo un elemento disuasivo y no es un sustituto de la supervisión adecuada de un adulto. El uso de restricciones de vuelco solo puede reducir, pero no eliminar, el riesgo de volcarse.**



General Dimensions / Dimensiones Generales

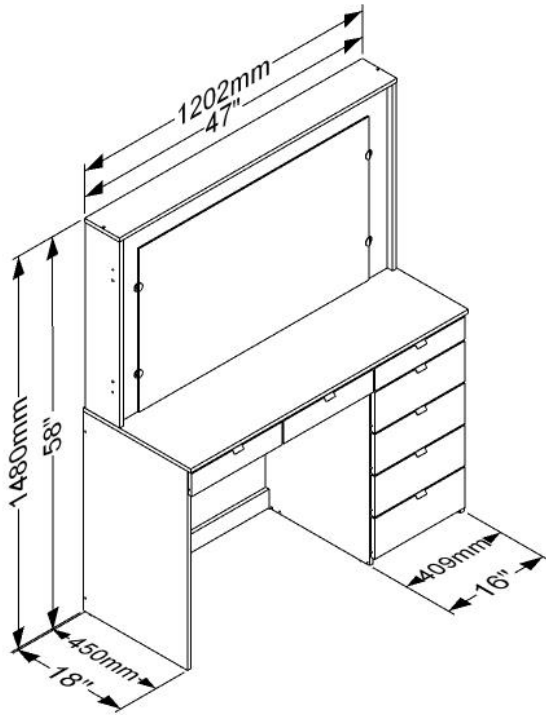

Maximum weight supported / Peso máximo soportado

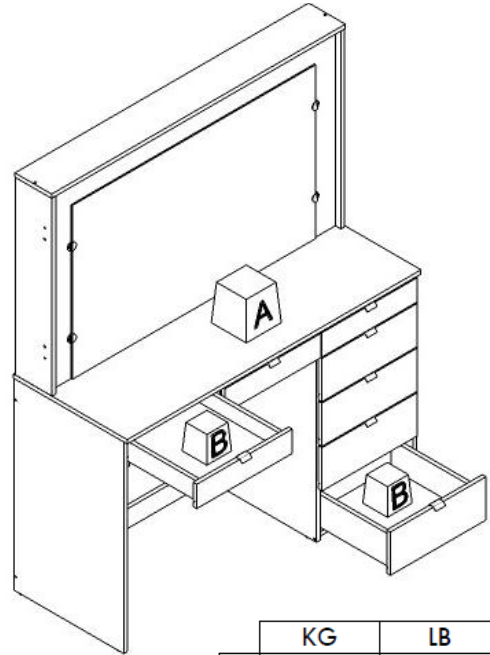

	KG	LB
A	20	44
B	3	6.6

Weight in pounds. / Peso en libras.

Note: weight must be evenly distributed.
 Nota: el peso debe estar distribuido uniformemente.

You will need / usted necesitará:

Tools not included / herramientas no incluidas



2 people
2 personas

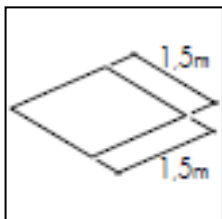

Recommended space for assemble
Espacio recomendado para el armado

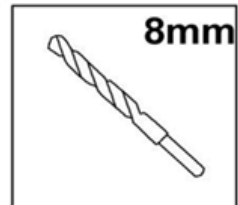
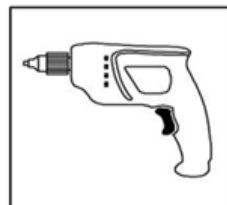
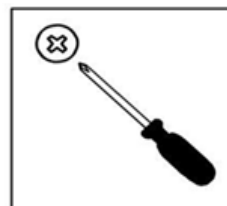

Note: Place a carpet or blanket in the assembly area to avoid damage to the parts during the process.
 Nota: Colocar una alfombra o manta en el area de armado para evitar daños en las piezas durante el proceso.

PARTS IDENTIFICATION / IDENTIFICACION DE PARTES



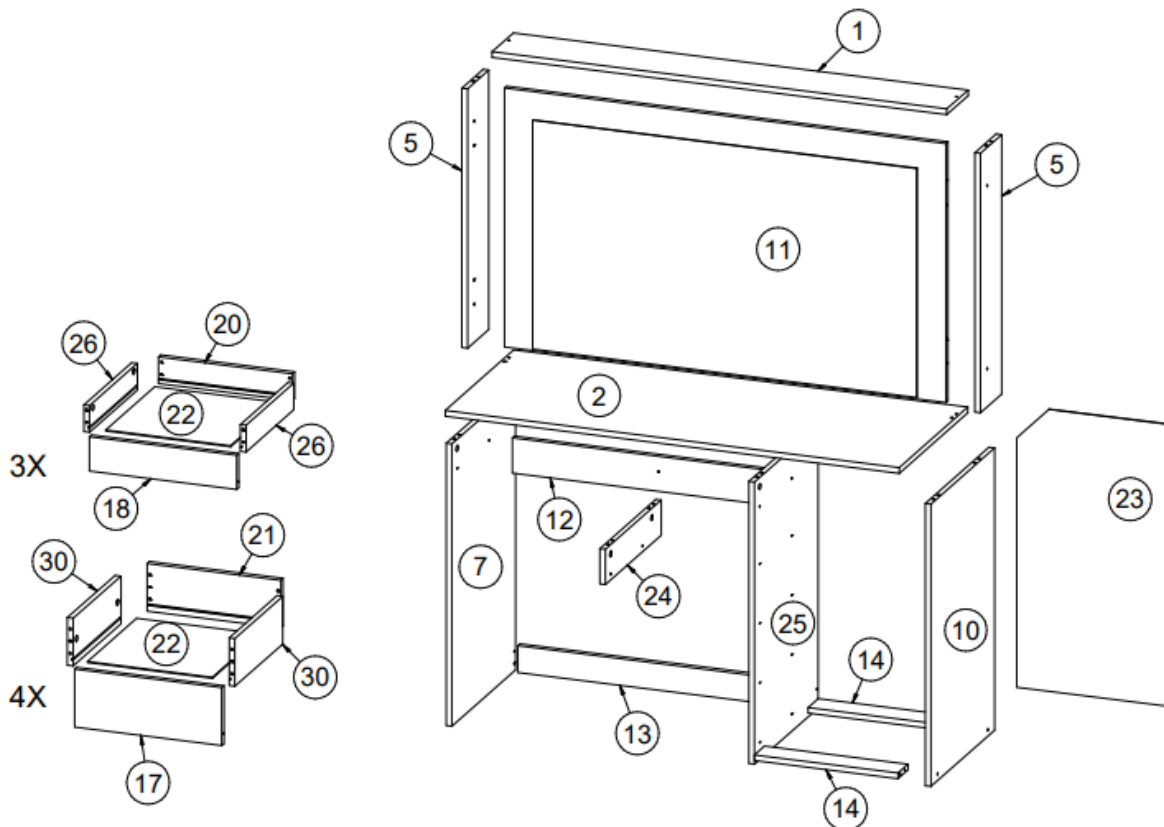







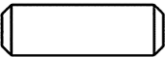
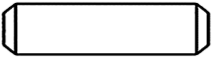

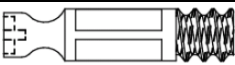



Nº	DESCRIPTION - DESCRIPCIÓN	QTY.
1	Top tray / Travesaño superior	1
2	Top base / Base superior	1
5	Side tray / Travesaño lateral	2
7	Left side / Lateral izquierdo	1
10	Right side / Lateral derecho	1
11	Mirror / Espejo	1
12	Crossbeam / Travesaño	1
13	Large footer / Zócalo grande	1
14	Small footer / Zócalo pequeño	2
17	Front of large drawer / Frontal de cajón grande	4
18	Front of small drawer / Frontal de cajón pequeño	3
20	Rear of small drawer / Posterior de cajón pequeño	3
21	Rear of large drawer / Posterior de cajón grande	4
22	Bottom of drawer / Fondo de cajón	7
23	Backboard / Fondo	1
24	Drawer divide support / Divisoria soporte cajón	1
25	Division / División	1
26	Side of small drawer / Lateral de cajón pequeño	6
30	Side of large drawer / Lateral de cajón grande	8



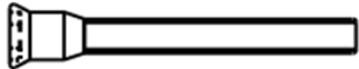

IDENTIFICATION OF ACCESSORIES / IDENTIFICACION DE ACCESORIOS

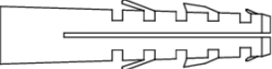
Note: the separation of the accessories before starting the assembly will facilitate it.

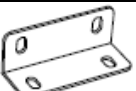
Nota: la separación de los accesorios antes de empezar el armado facilitará el mismo.

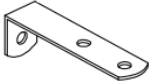
NUMBER		DESCRIPTION	QTY
A		Wooden dowel / Pin (6 x 30 mm)	64
AS		Wooden dowel / Pin (6 x 50 mm)	2
AZ		Allen key / Llave allen	1
B		Simple minifix screw / Tornillo minifix simple	36
C		Drum lock / Tambor minifix	36
CR1		Metallic left slide 350mm / corredera lateral izquierda 350mm	7
CR2		Metallic right slide 350 mm / Corredera lateral derecha 350mm	7
CR3		Left drawer slide 350mm / Corredera cajón izquierda 350mm	7
CR4		Right drawer slide 350 mm/ Corredera cajón derecha 350 mm	7
D		Flat head screw / Tornillo cabeza plana (3,5 x 14 mm)	76
DE		Flanged head screw / Tornillo cabeza flangeada (5 x 50 mm)	1
DZ		Structural screw / Tornillo estructural (5 x 50 mm)	17
EN		Nail / Clavo	29
FM		Screw Cap / Tapa de tornillo	12
K		Mirror support / Soporte espejo	4
L		Bushing / Tapón	1
P		Flat head screw / Tornillo cabeza plana (6 x 8 mm)	8
PX		Handle / Tirador	7
Q		Metallic angle plates / Soporte de metal	2

V		Metallic angle plate / Soporte de metal	1
X		Small plastic foot / Pie plástico	7
Y		Adhesive bore patch / Tapón adhesivo	28

PRE-ASSEMBLY / PRE- ARMADO

1. Fix **wooden dowel** (A) to **crossbeam** (12) and **large footer** (13).
Fijar **pin** (A) a **travesaño** (12) y **zócalo grande** (13).

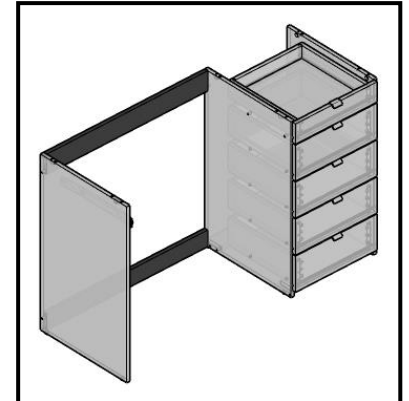
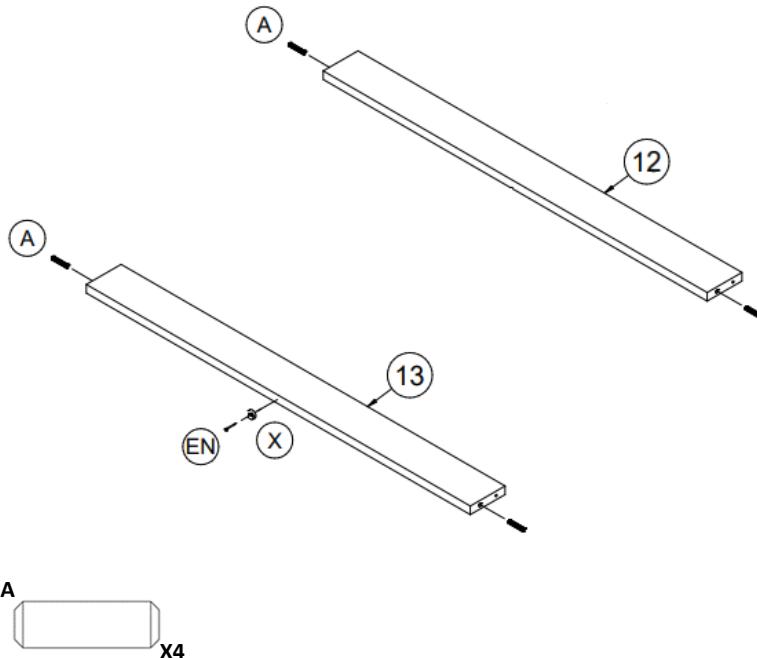

2. Fix **wooden dowel** (A) to **small footer** (14) x2.
Fijar **pin** (A) a **zócalo pequeño** (14) x2.

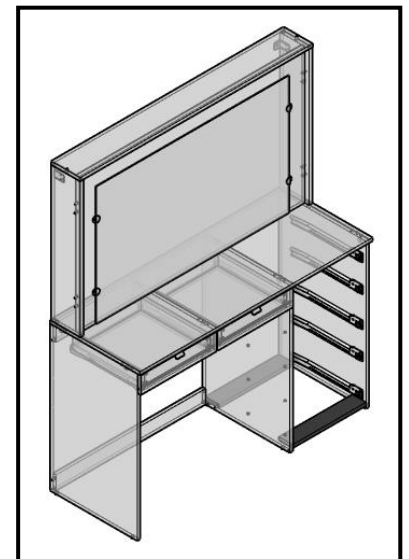
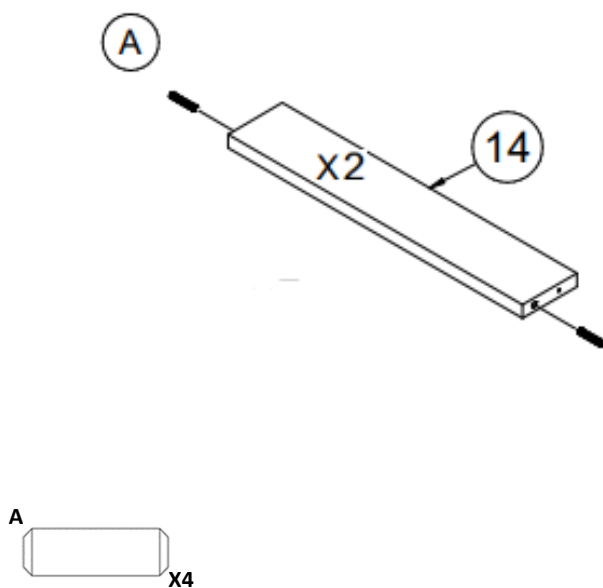

3. Fix **simple minifix screw (B)** to **top base (2)**.
 Fijar **ornillo minifix simple (B)** a **base superior (2)**.

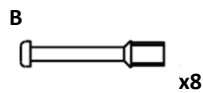
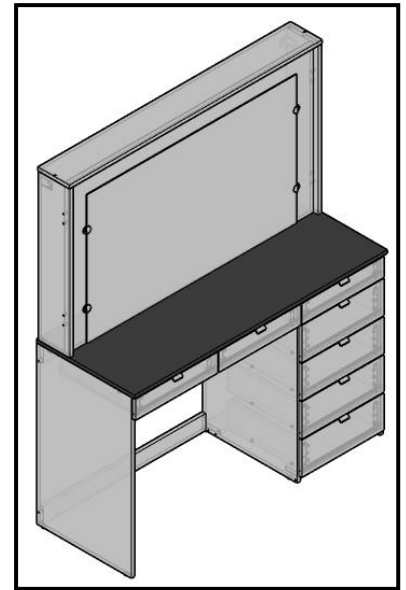
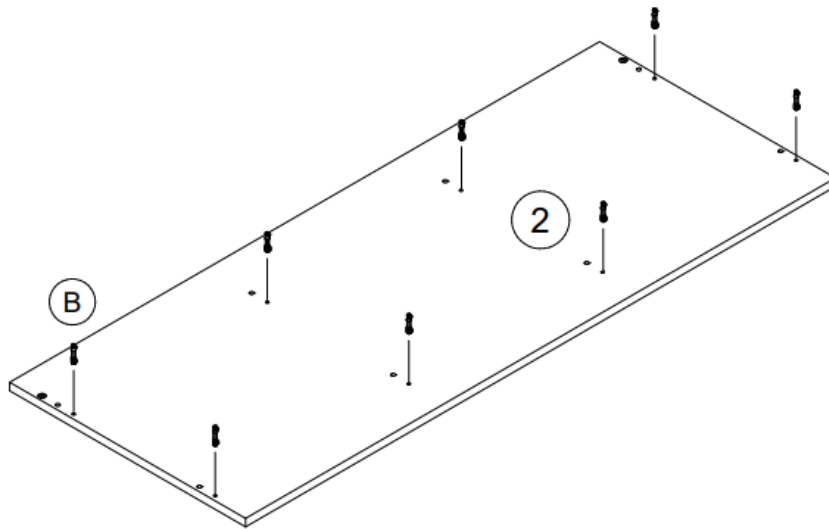

4. Fix **wooden dowel (A)**, **metallic left slide (CR1)** and **plastic foot (X)** to **left side (7)**.
 Fijar **pin (A)**, **corredera lateral izquierda (CR1)** y **pie plástico (X)** a **lateral izquierdo (7)**.

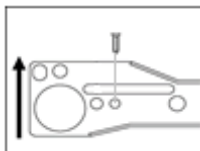
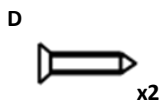
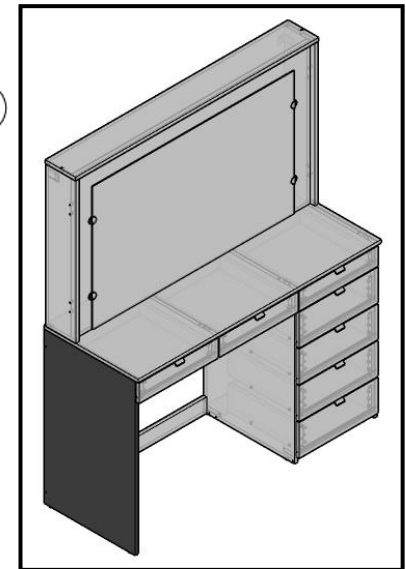
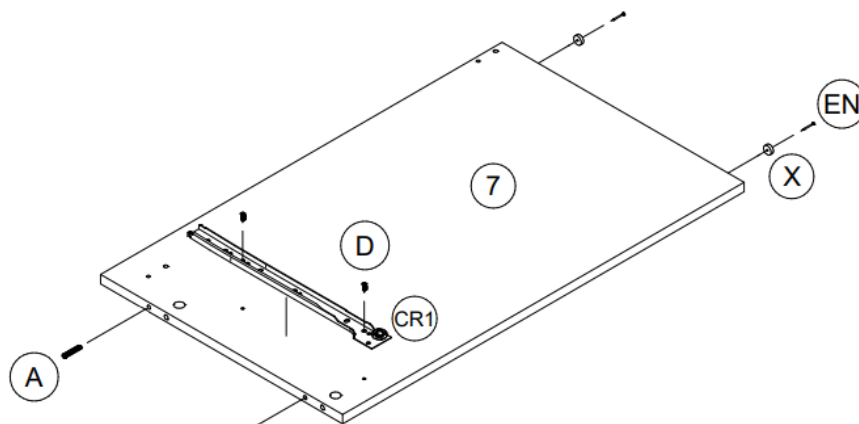

Note: the two upper holes have to be facing up.
Nota: los dos agujeros superiores deben estar hacia arriba.

5. Fix **wooden dowel** (A) to **side of large drawer** (30) x8 and **side of large drawer** (26) x6.
 Fijar **pin** (A) a **lateral de cajón grande** (30) x8 y **lateral de cajón pequeño** (26) x6.

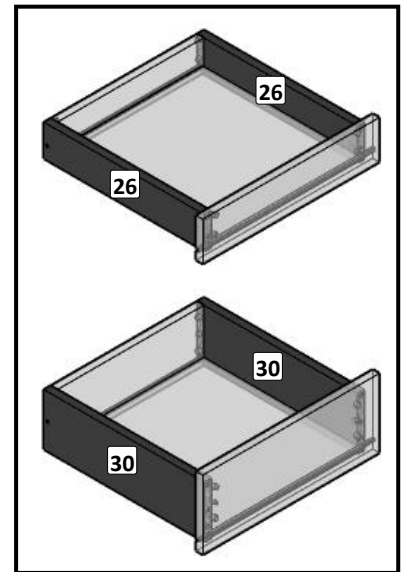
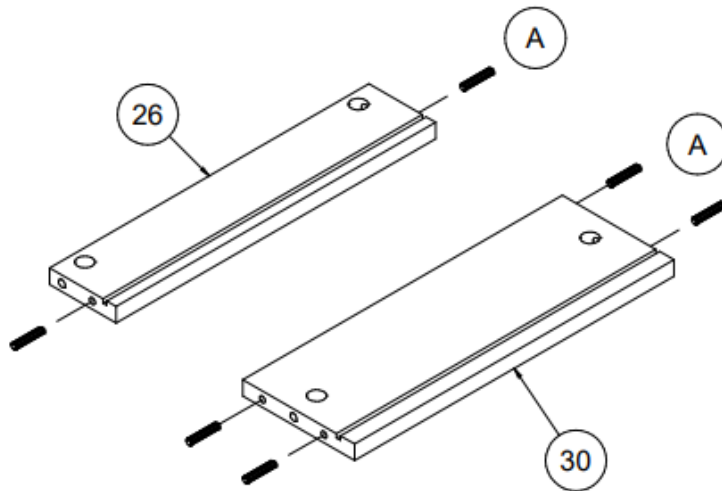

6. Fix **simple minifix screw** (B) to **rear of small drawer** (20) x3 and **rear of large drawer** (21) x4.
 Fijar **tornillo minifix simple** (B) a **posterior de cajón pequeño** (20) x3 y **posterior de cajón grande** (21) x4.

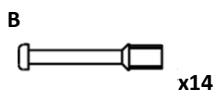
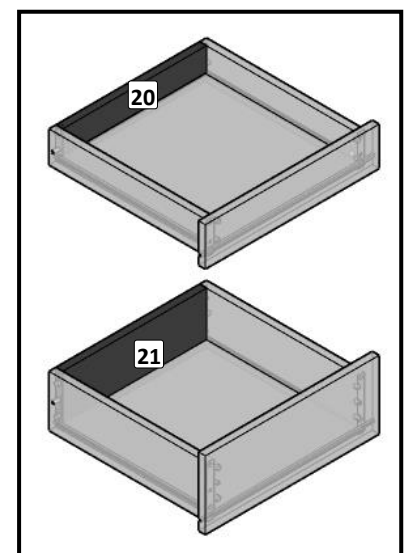
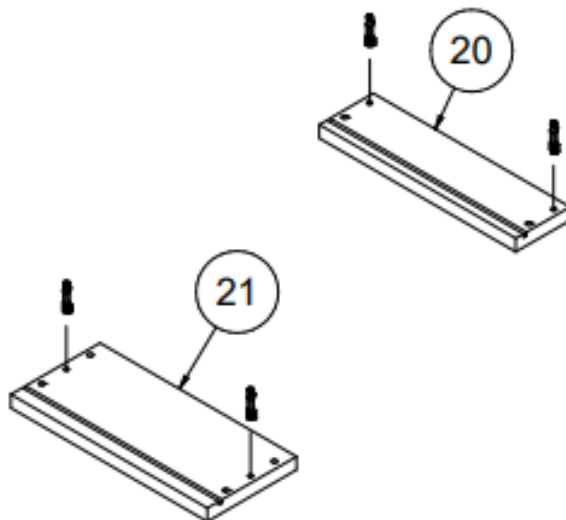

7. Fix **simple minifix screw** (B) to **front of large drawer** (17) x4 and **front of small drawer** (18) x3.
 Fijar **tornillo minifix simple** (B) a **frente de cajón grande** (17) x4 y **frente de cajón pequeño** (18) x3

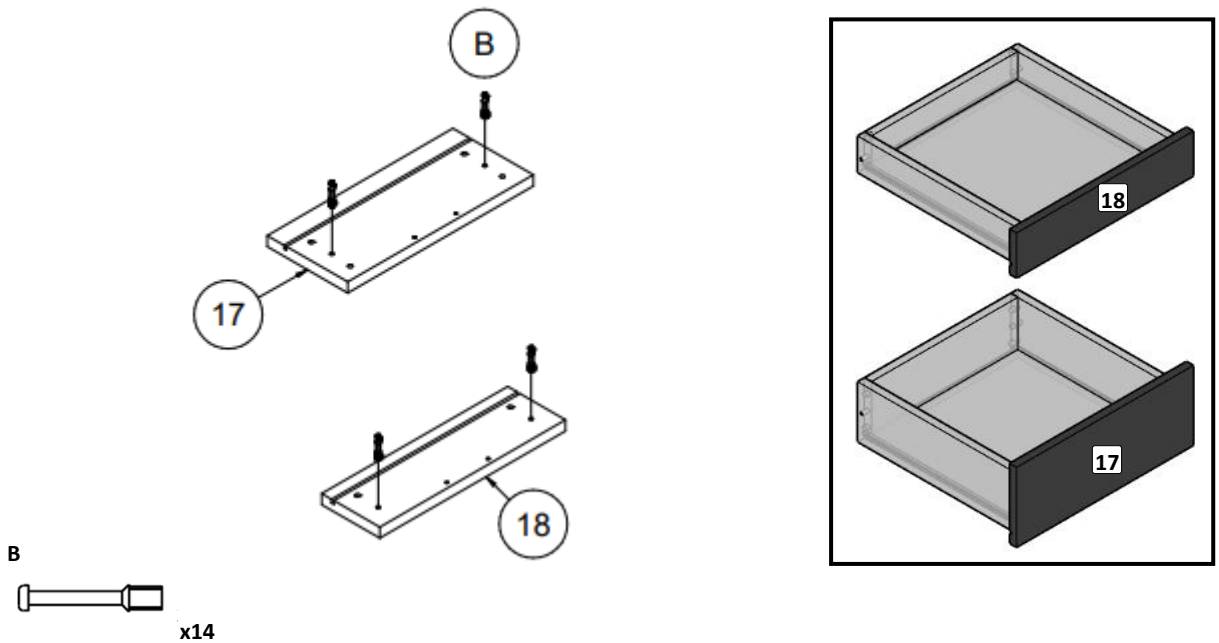

8. Fix **wooden dowel** (A), **metallic right slide** (CR2) to **drawer divide support** (24). Flip **drawer divide support** (24) and fix **metallic left slide** (CR1).
 Fijar **pin** (A), **corredera lateral derecha** (CR2) a **divisoria soporte cajón** (24). Voltrear **divisoria soporte cajón** (24) y fijar **corredera lateral izquierda** (CR1).

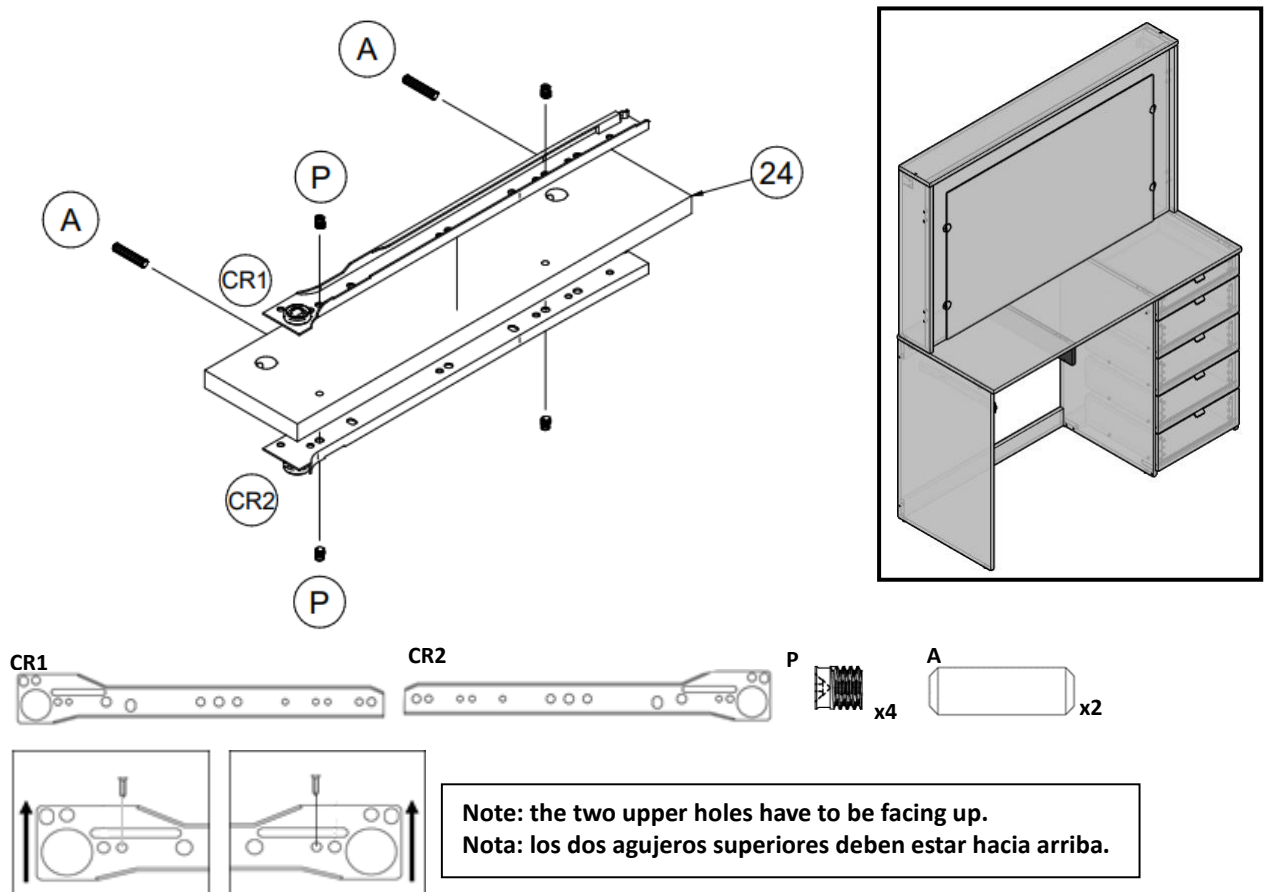

9. Fix **wooden dowel (A)** to **side tray (5)** x2.
 Fijar **pin (A)** a **travesaño lateral (5)** x2.

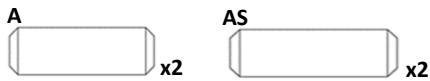
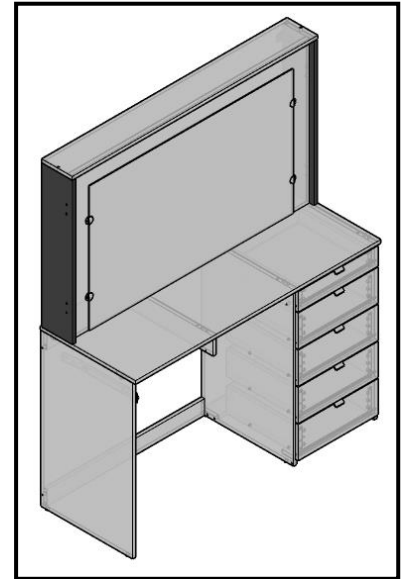
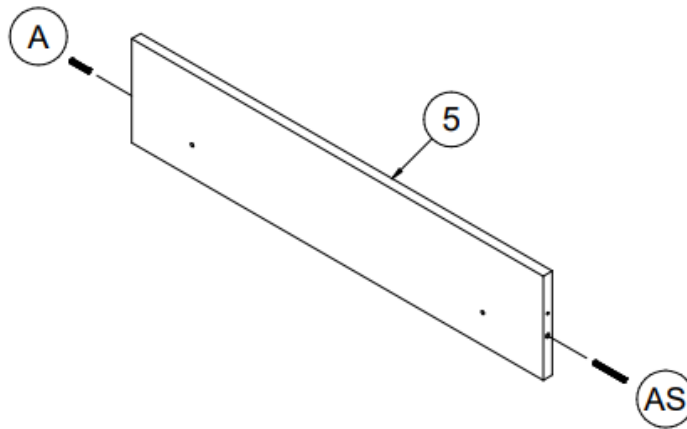

10. Fix **wooden dowel (A)**, **metallic right slide (CR2)** and **plastic foot (X)** to **right side (10)**.
 Fijar **pin (A)**, **corredera lateral derecha (CR2)** y **pie plástico (X)** a **lateral derecho (10)**.

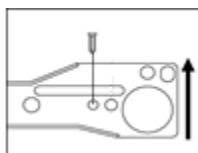
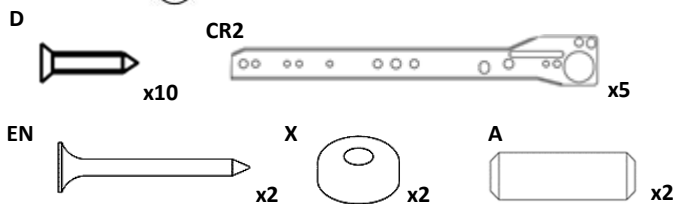
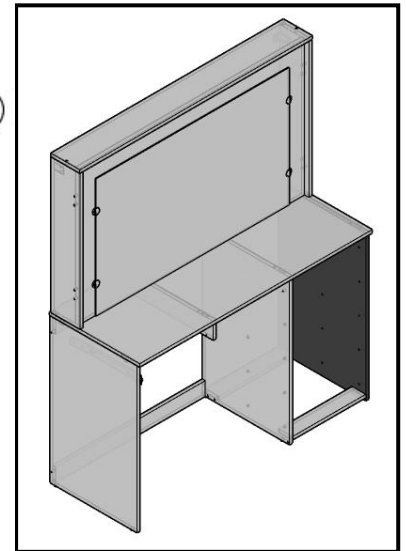
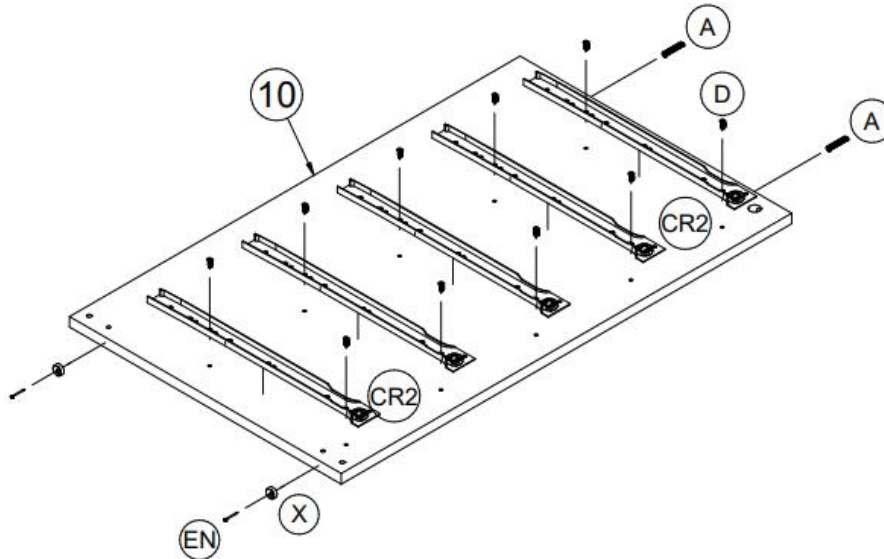

Note: the two upper holes have to be facing up.
 Nota: los dos agujeros superiores deben estar hacia arriba.

11. Fix **wooden dowel** (A), **metallic left slide** (CR1) to **division** (25). Flip **division** (25) and fix **metallic right slide** (CR2) and **plastic foot** (X).

Fijar **pin** (A), **corredera lateral izquierda** (CR1) a **división** (25). Voltrear **división** (25) y fijar **corredera lateral derecha** (CR2) y **pie plástico** (X).

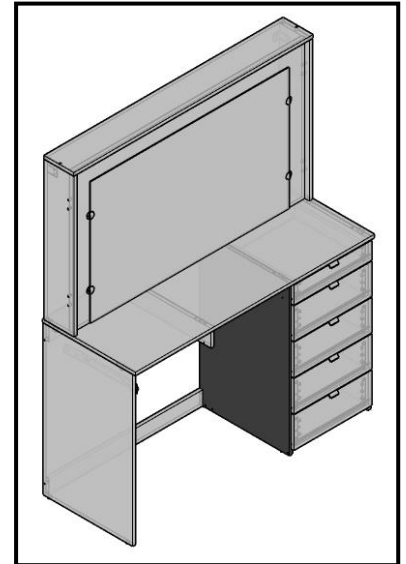
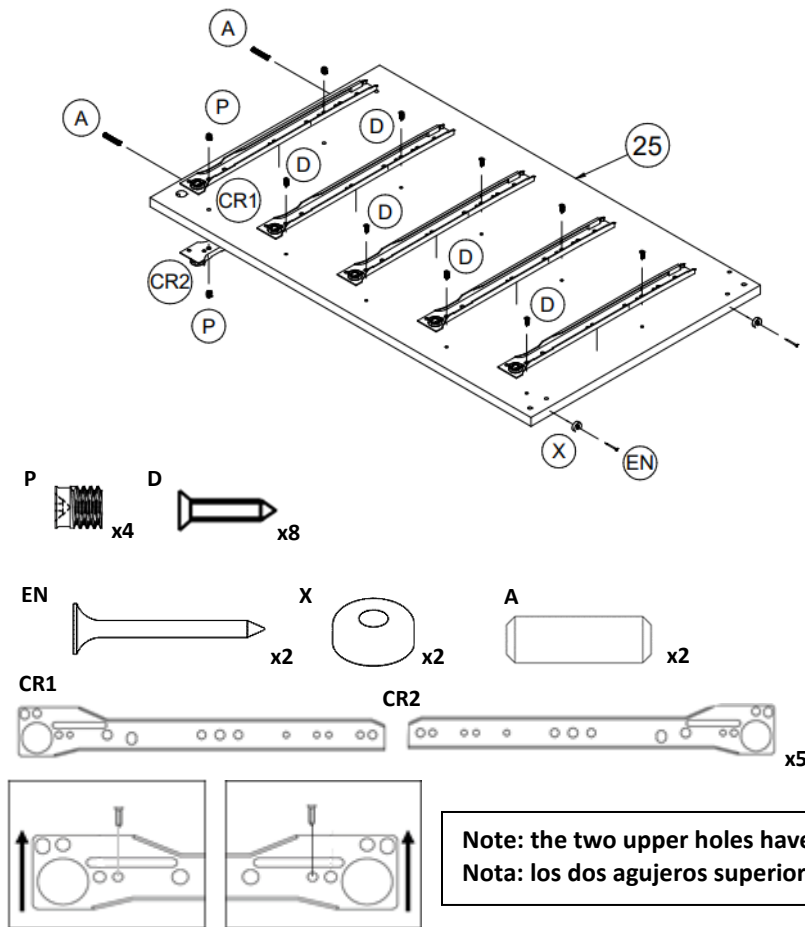

Note: the two upper holes have to be facing up.
Nota: los dos agujeros superiores deben estar hacia arriba.

12. Fix **pin** (A) and **mirror support** (K) to **mirror** (11).

Fijar **pin** (A) y **soporte espejo** (K) a **espejo** (11).

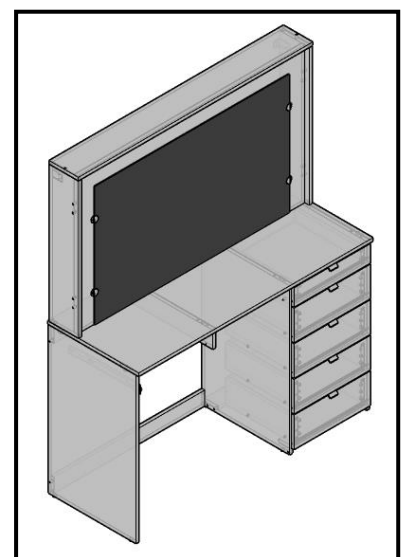
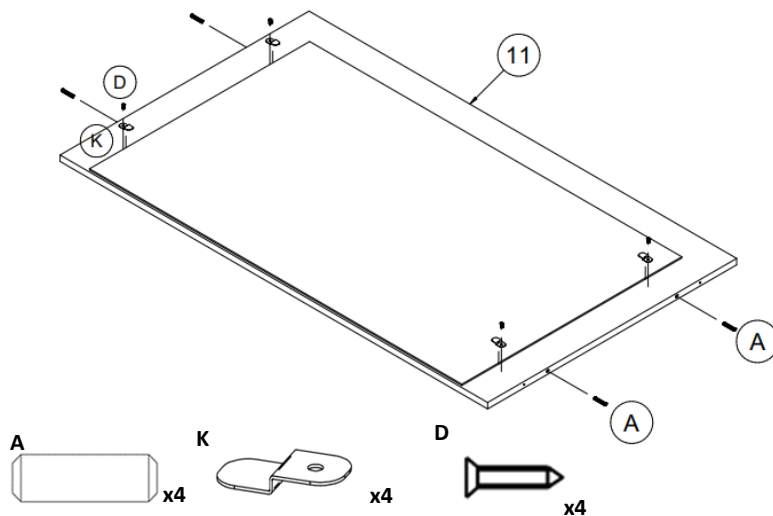

Note: It's essential fix mirror support (K) for safety.
Nota: es esencial fijar el soporte espejo (K) para la seguridad.

ASSEMBLY / ARMADO

13. Fix **side tray** (5) x2 to **mirror** (11).
 Fijar **travesaño lateral** (5) x2 a **espejo** (11).

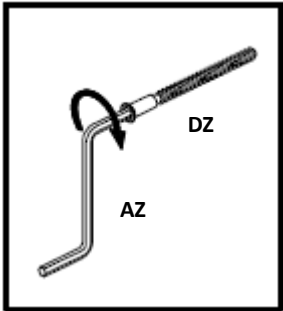
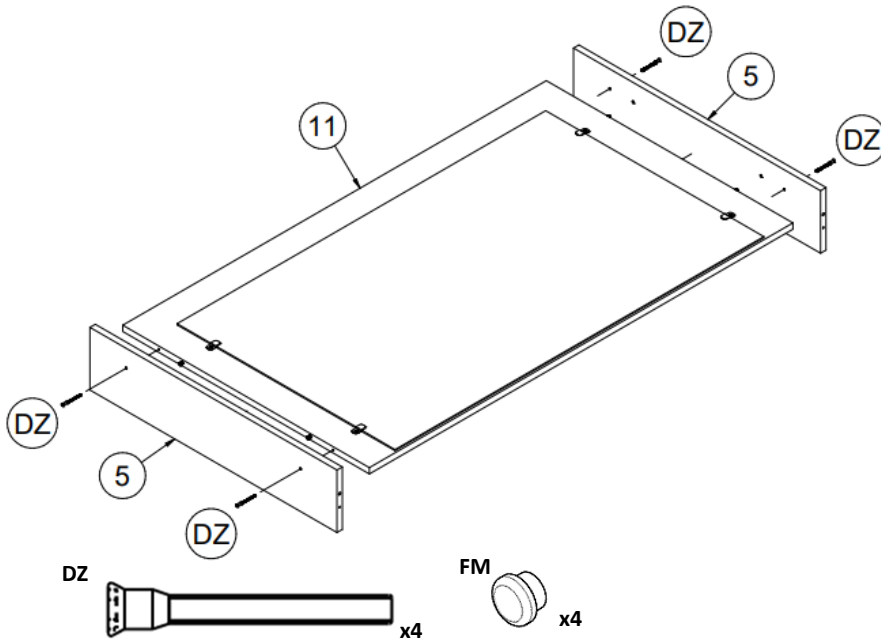

Note: use the allen key (AZ) to adjust the structural screws (DZ).
Nota: usar la llave allen (AZ) para ajustar los tornillos estructurales

14. Fix **top tray** (1) to previous assembly.
 Fijar **travesaño superior** (1) a ensamble previo.

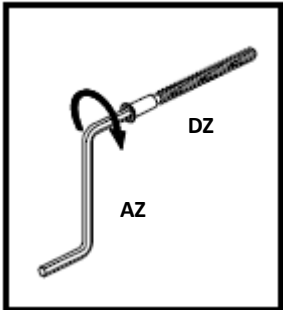
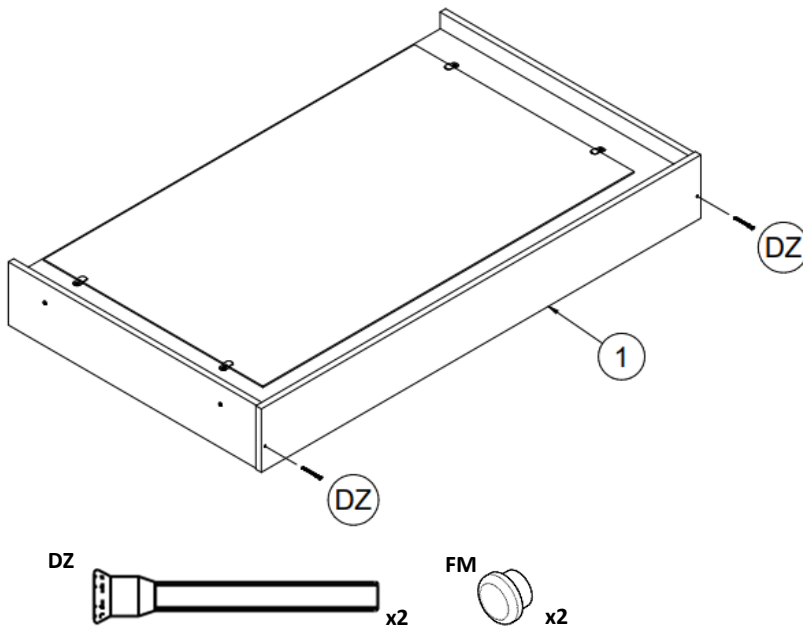

Note: use the allen key (AZ) to adjust the structural screws (DZ).
Nota: usar la llave allen (AZ) para ajustar los tornillos estructurales (DZ).

15. Fix **top base** (2) and **drawer divide support** (24) to previous assembly.
 Fijar **base superior** (2) y **divisoria soporte cajón** (24) a ensamble previo.

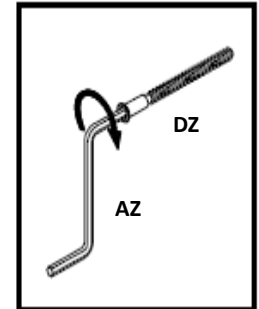
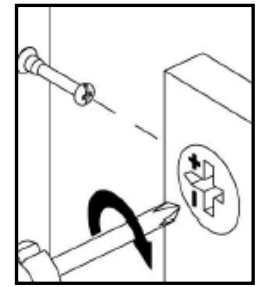
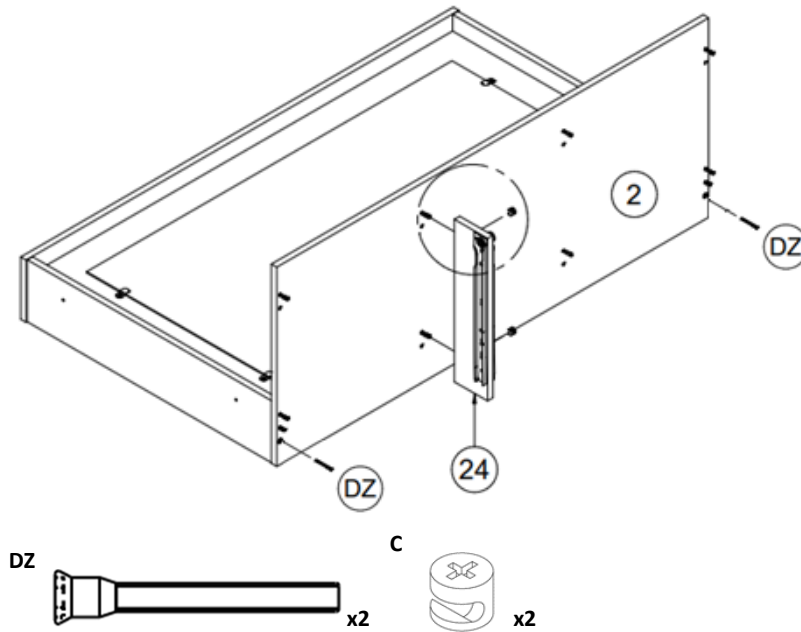

Note: use the allen key (AZ) to adjust the structural screws (DZ).
 Nota: usar la llave allen (AZ) para ajustar los tornillos estructurales (DZ).

16. Fix **crossbeam** (12) and **large footer** (13) to **left side** (7) and **division** (25).
 Fijar **travesaño** (12) y **zócalo grande** (13) a **lateral izquierdo** (7) y **división** (25).

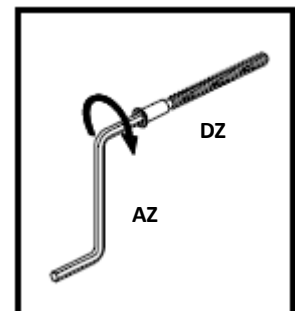
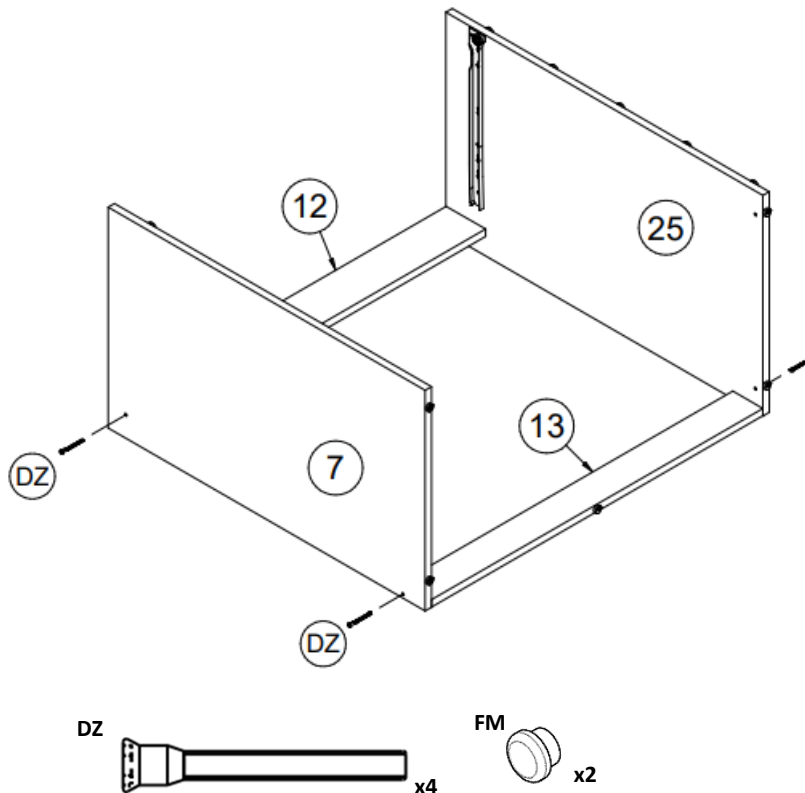

Note: use the allen key (AZ) to adjust the structural screws (DZ).
 Nota: usar la llave allen (AZ) para ajustar los tornillos estructurales (DZ).

17. Fix **small footer** (14) x2 and **right side** (10) to previous assembly.
 Fijar **zócalo pequeño** (14) x2 y **lateral derecho** (10) a ensamble previo.

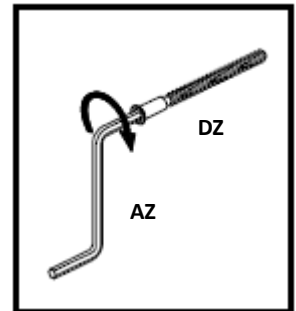
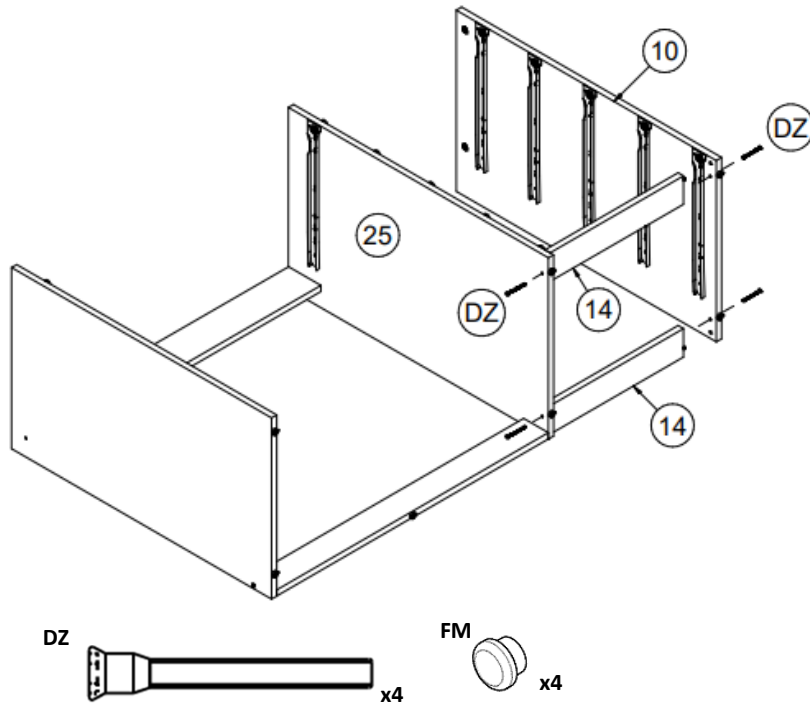

Note: use the allen key (AZ) to adjust the structural screws (DZ).
Nota: usar la llave allen (AZ) para ajustar los tornillos estructurales (DZ).

18. Fix both previous assemblies (14 and 17).
 Fijar ambos ensambles previos (14 y 17).

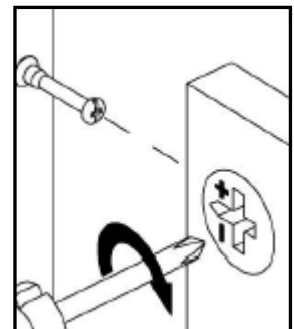
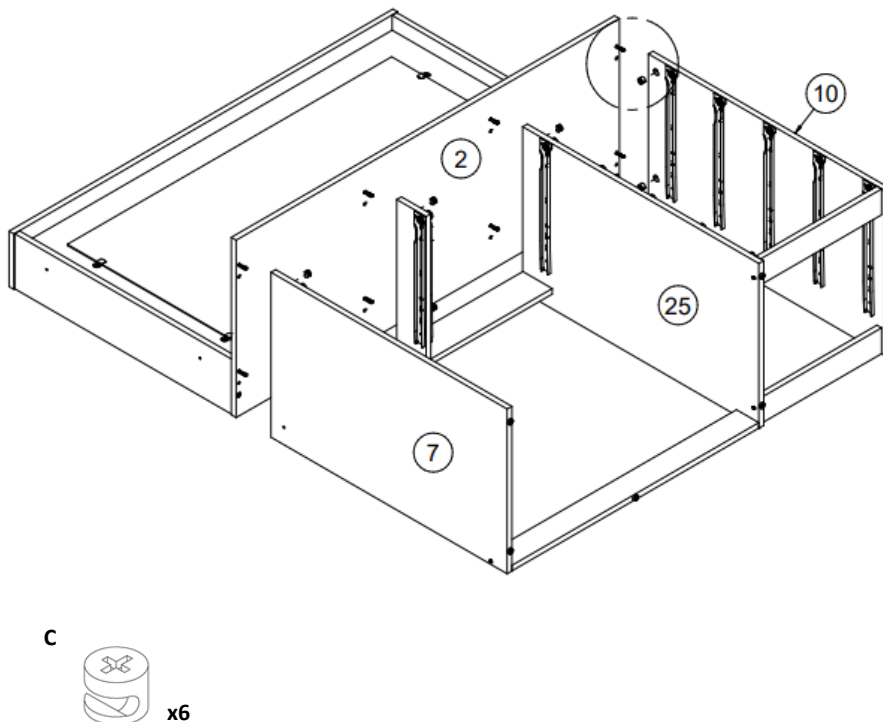

19. Fix **backboard** (23) and **metallic angle plates** (Q) to previous assembly.
 Fijar **fondo** (23) y **soporte de metal** (Q) a ensamble previo.

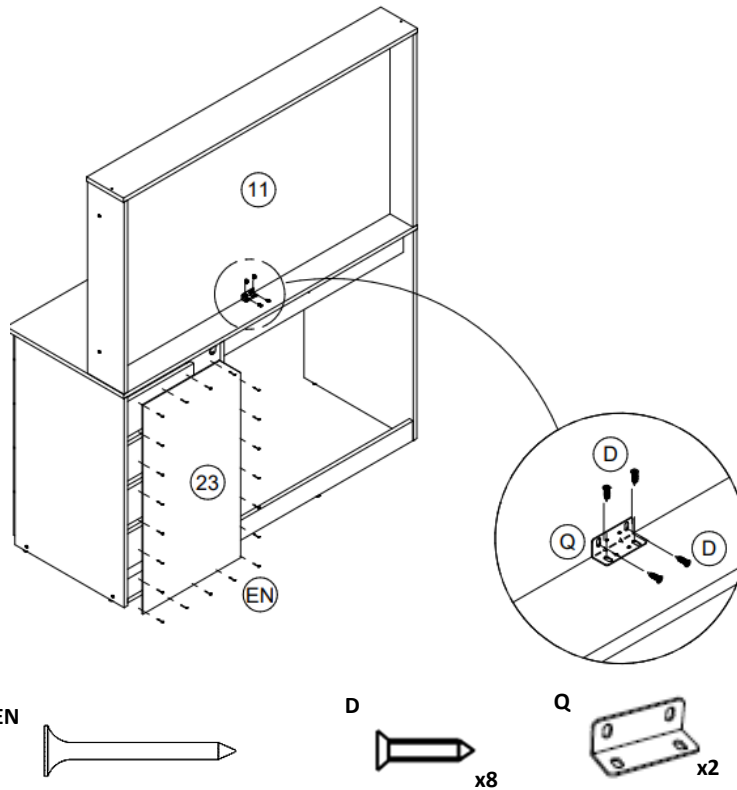

20. Fix **metallic angle plate** (V) to **top base** (2).
 Fijar **soporte de metal** (V) a **base superior** (2).

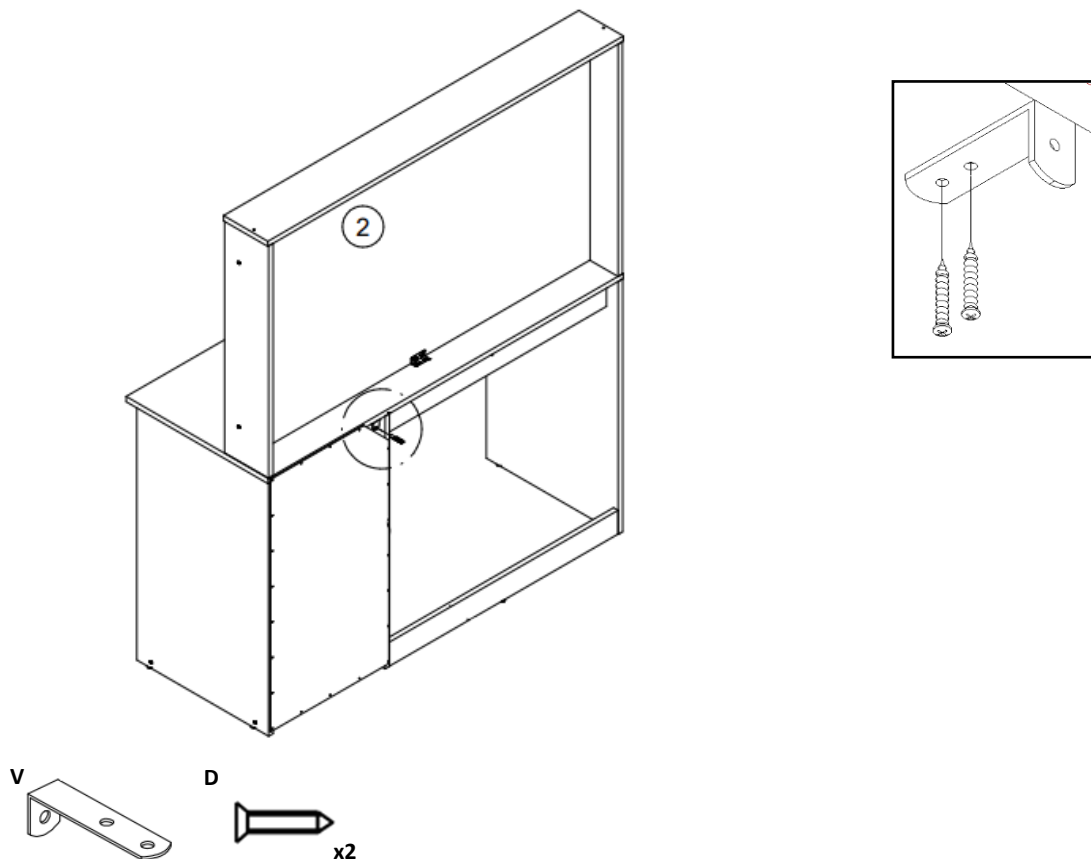

21. Fix **bottom of drawer** (22) x4 and **side of large drawer** (30) x8 to rear of **large drawer** (21) x4.
 Fijar **fondo de cajón** (22) x4 y **lateral izquierdo de cajón grande** (30) x8 a **trasero de cajón grande** (21) x4.

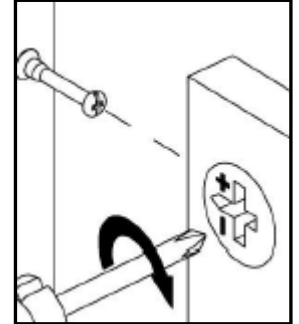
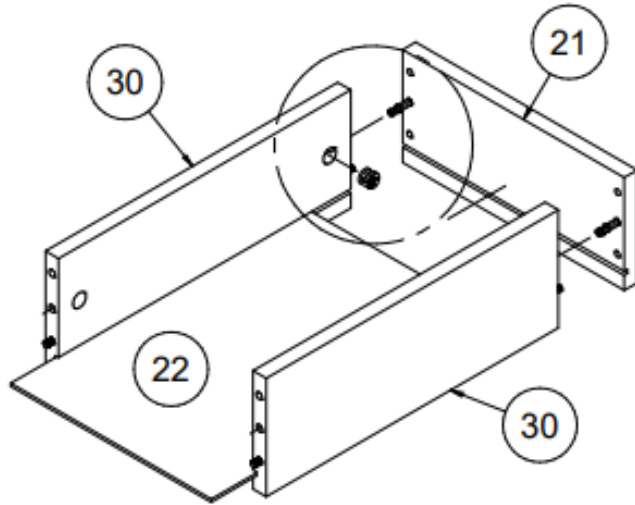

x4



22. Fix **front large drawer** (17) x4 and **handle** (PX) x4 to previous assembly.
 Fijar **frente del cajón grande** (17) x4 y **tirador** (PX) x4 a ensamble previo.

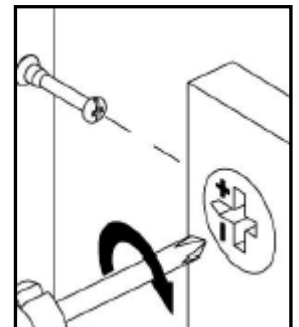
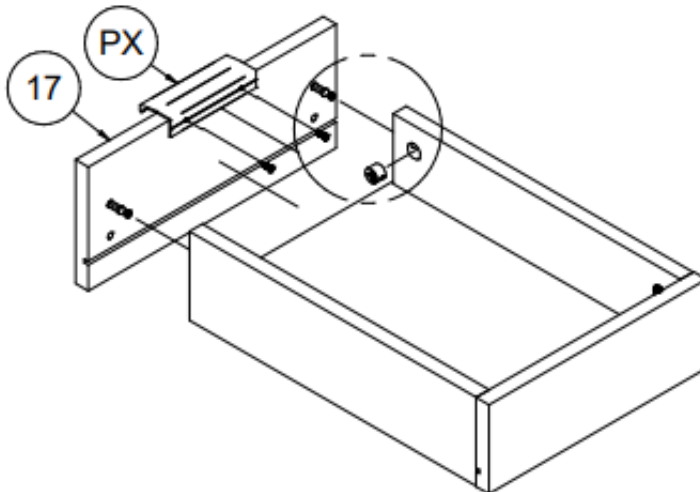

x4

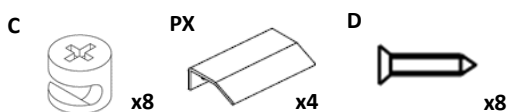

23. Fix **left drawer slide** (CR3) x4 and **right drawer slide** (CR4) x4 to large drawer x4.

Fijar **corredera de cajón izquierdo** (CR3) x4 y **corredera de cajón derecho** (CR4) x4 a cajón grande x4.

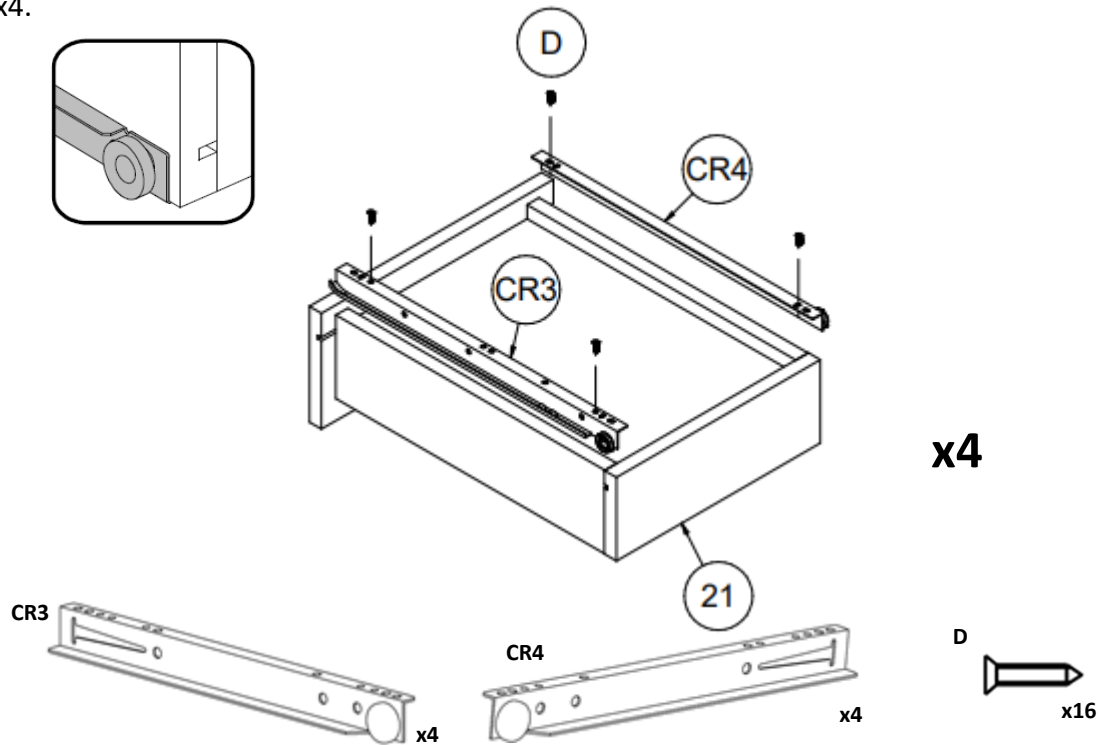

Note: the missing holes must be made with the screwdriver and the corresponding screw.
Nota: los agujeros faltantes deben hacerse con el destornillador y el tornillo correspondiente.

24. Fix **bottom of drawer** (22) x3 and **side of small drawer** (26) x6 to rear of small drawer (20) x3.

Fijar **fondo de cajón** (22) x3 y **lateral de cajón pequeño** (26) x6 a **trasero de cajón pequeño** (20) x3.

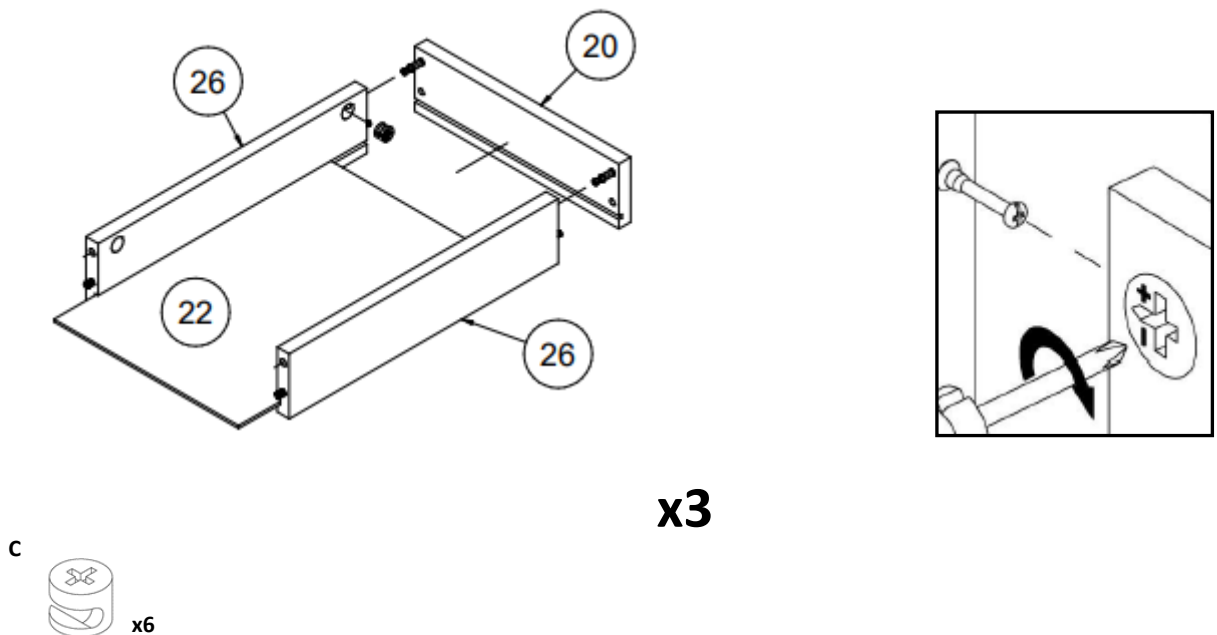

x3

25. Fix **front of small drawer** (18) x3 and **handle** (PX) x3 to previous assembly.
 Fijar **frente de cajón pequeño** (18) x3 y **tirador** (PX) x3 a ensamble previo.

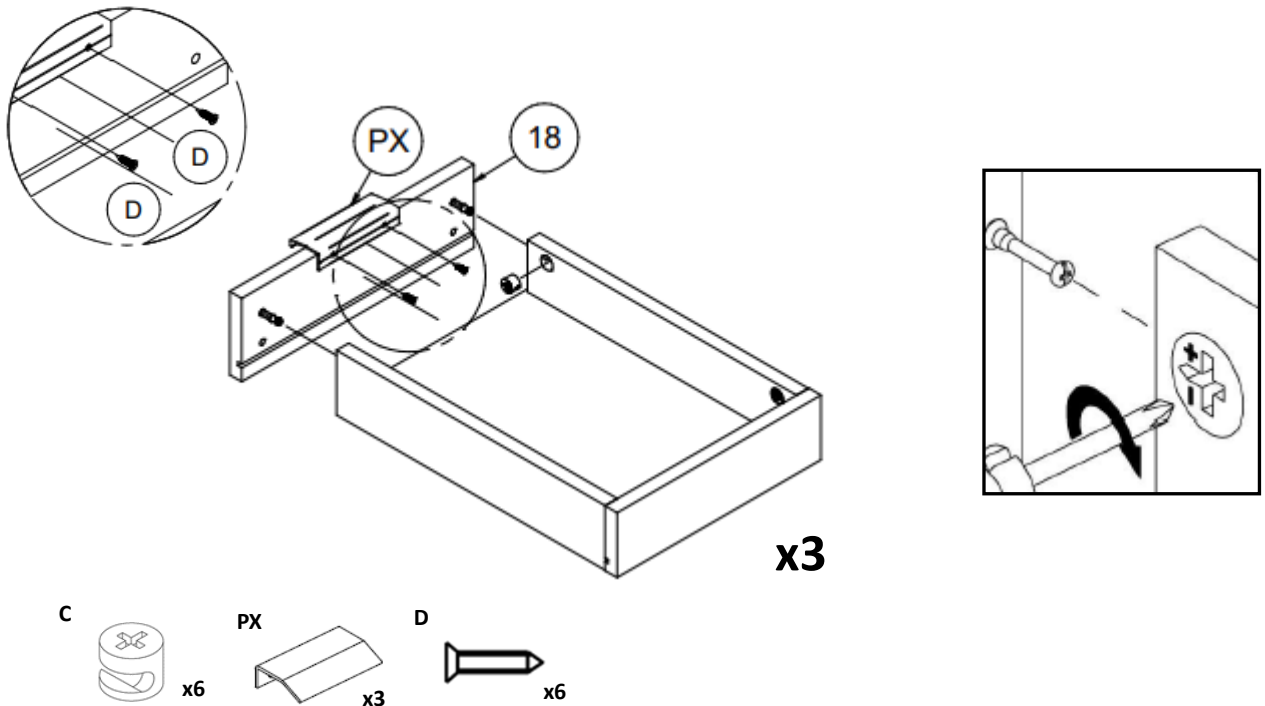

26. Fix **left drawer slide** (CR3) x3 and **right drawer slide** (CR4) x3 to small drawer x3.
 Fijar **corredera de cajón izquierdo** (CR3) x3 y **corredera de cajón derecho** (CR4) x3 a cajón pequeño x3.

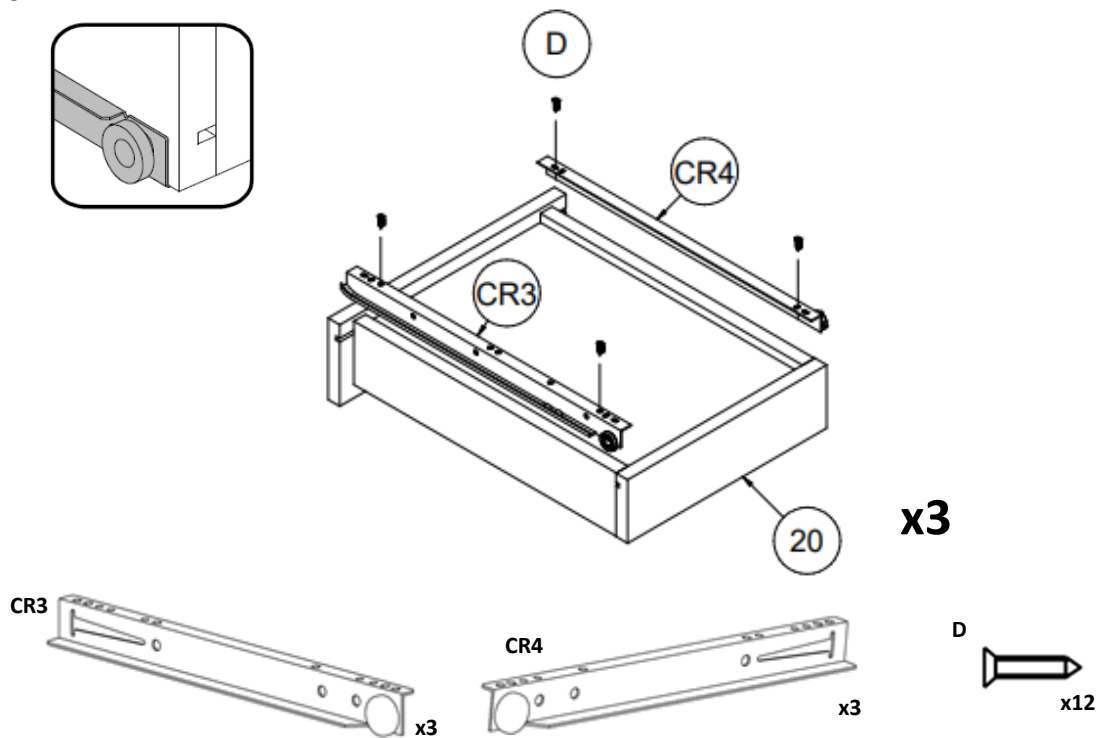

Note: the missing holes must be made with the screwdriver and the corresponding screw.
 Nota: los agujeros faltantes deben hacerse con el destornillador y el tornillo correspondiente.

27. Place drawers.
Colocar cajones.

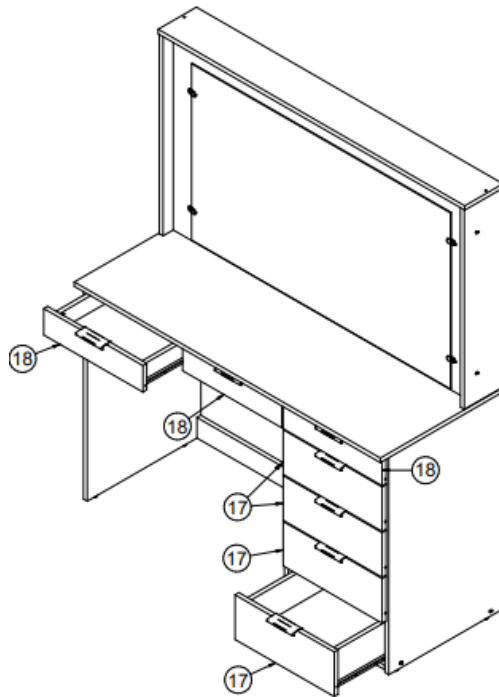

28. And finally fix furniture to the wall.
Y finalmente fijar mueble a la pared.

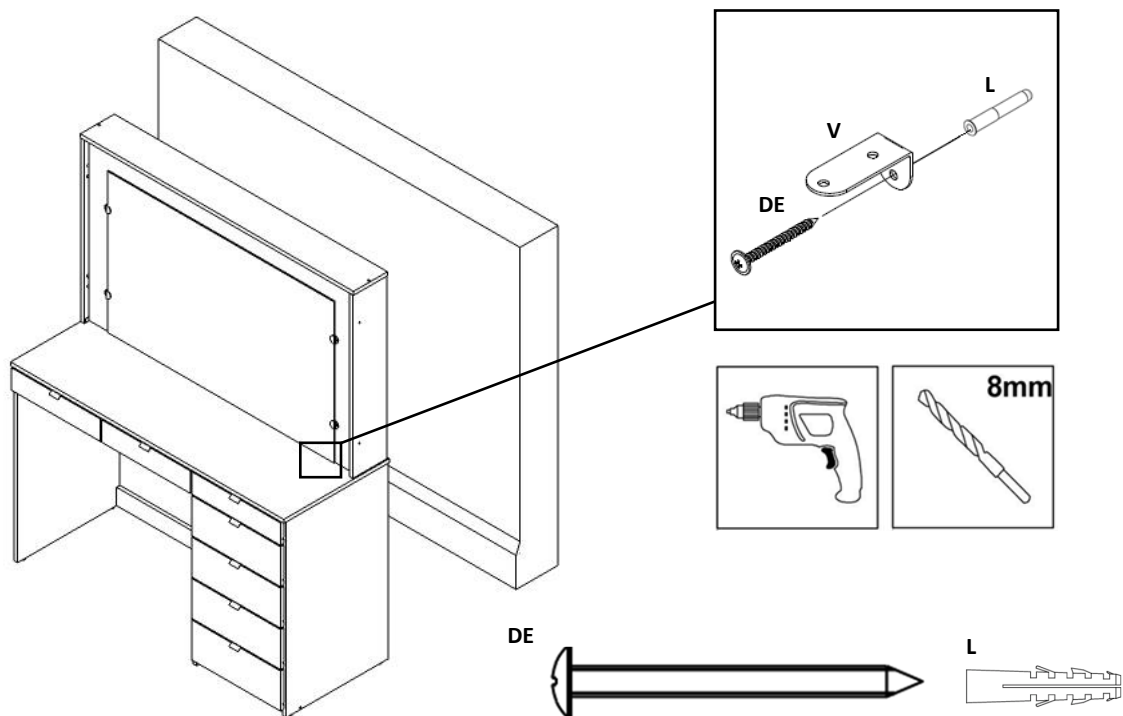

WARNING.

For security measures it is recommended to fix the furniture to the wall to avoid overturning of it, if this happens it can cause serious or fatal injuries.

ATENCIÓN.

Por medidas de seguridad se recomienda fijar el mueble a la pared para evitar volcamiento del mismo, si esto llegase a ocurrir puede causar lesiones graves o fatales.

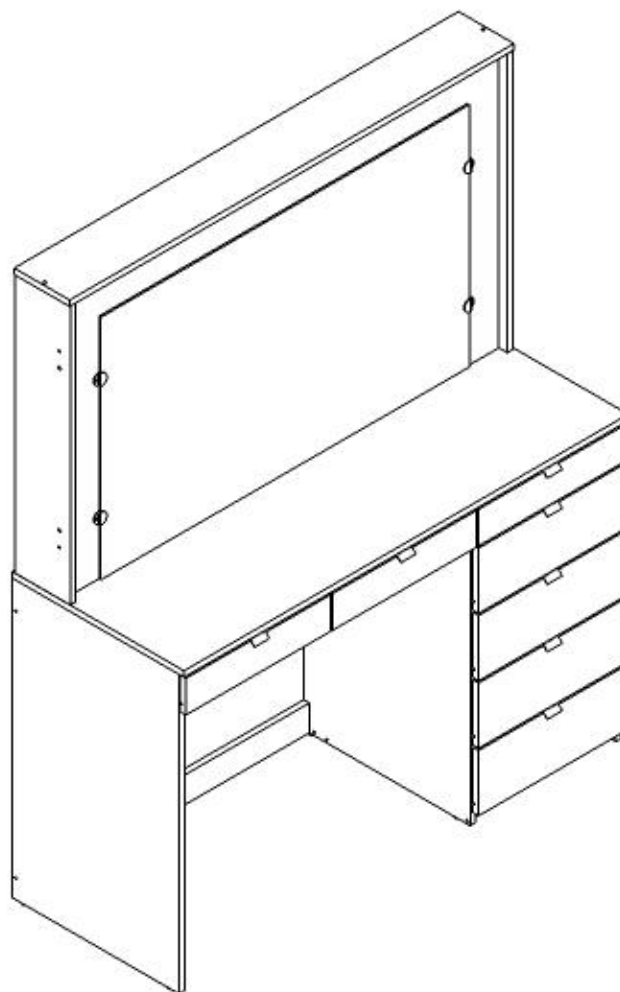

***Congratulations, you have assembled your DRESSING TABLE WITH MIRROR!!!
¡¡¡Felicitaciones, has armado tu Tocador con Espejo!!!***

1609 Boahaus DRESSING TABLE WITH MIRROR Warranty**6-Months Limited Warranty**

1. Boahaus, LLC provides limited warranty coverage to the original purchaser of this product for a period of six months from the date of purchase against defects in materials or workmanship of Boahaus furniture components. As used in this Warranty, “defect” means imperfections in components which substantially impair the utility of the product. This Warranty gives you specific legal rights, and you may also have other rights which vary from state to state.
2. There is no warranty coverage for defects or conditions that result from the failure to follow product assembly instructions, information or warnings, misuse or abuse, intentional damage, fire, flood, alteration or modification of the product, or use of the product in a manner inconsistent with its intended use, nor any condition resulting from incorrect or inadequate maintenance, cleaning, or care. There is also no warranty coverage for rented products or any products purchased “used” or “as is”, at a distress or going-out-of business sale, or from a liquidator.
3. As the exclusive remedy under this Warranty, Boahaus will (at its sole option) repair, replace or refund the value of any defective furniture component. Boahaus may require independent confirmation of the claimed defect and proof of purchase. Replacement parts will be warranted for only the remaining period of the original Warranty. BOAHAUS SHALL HAVE NO LIABILITY for ANY INCIDENTAL OR CONSEQUENTIAL DAMAGES OF ANY KIND and all such damages are EXCLUDED FROM THIS WARRANTY, such as loss of use, disassembly, transportation, labor or damage to property on or near the product. Some states do not allow the exclusion or limitation of incidental or consequential damages, so the above limitation or exclusion may not apply to you.
4. This Warranty applies only to warranted defects that first arise and are reported to Boahaus within the warranty coverage period. The Warranty cannot be transferred to subsequent owners or users of the product, and it shall be immediately void in the event the product is resold, transferred, leased or rented to any third party or person other than the original purchaser.
5. THERE ARE NO OTHER WARRANTIES APPLICABLE TO THIS PRODUCT. Under the laws of certain states, there may be no implied warranties from Boahaus and all implied warranties, INCLUDING ANY IMPLIED WARRANTY OF MERCHANTABILITY OR FITNESS FOR A PARTICULAR PURPOSE are disclaimed where allowed by law. TO THE EXTENT ANY IMPLIED WARRANTIES ARE APPLICABLE, ANY IMPLIED WARRANTIES, INCLUDING ANY IMPLIED WARRANTY OF MERCHANTABILITY OR FITNESS FOR A PARTICULAR PURPOSE, ARE LIMITED IN DURATION TO THE DURATION OF THIS EXPRESS WARRANTY or the minimum period allowed by law, whichever is shorter. Some states do not allow limitations on how long an implied Warranty lasts, so the above limitation may not apply to you.
6. For Warranty inquiries, questions about disposition or claims, please visit our website www.boahaus.com. You can also contact Boahaus at +1 (787) 688-1254 or email at administracion@boahaus.com. Boahaus may require Warranty claims to be submitted in writing to:

Boahaus LLC.
1250-1252
Ave. Franklin Delano Roosevelt,
San Juan, PR 00926.

Please include your sales receipt or other proof of purchase and a specific description of the product defect.

Garantía de Tocador con Espejo 1609 Boahaus**Garantía limitada de 6 meses**

1. Boahaus, LLC proporciona cobertura de garantía limitada al comprador original de este producto por un período de 6 meses a partir de la fecha de compra contra defectos en materiales o mano de obra de componentes de muebles de Boahaus. Como se especifica en esta Garantía, "defecto" significa imperfecciones en componentes que perjudican sustancialmente la utilidad del producto. Esta Garantía le otorga derechos legales específicos y también puede tener otros derechos que varían de un estado a otro.
2. No hay cobertura de garantía por defectos o condiciones que resulten del incumplimiento de las instrucciones del producto, o advertencias, uso indebido o abuso, daño intencional, incendio, inundación, alteración o modificación del producto o uso del producto de manera inconsistente con su uso previsto, o cualquier condición resultante de mantenimiento incorrecto o inadecuado, limpieza o cuidado. Tampoco hay cobertura de garantía para productos alquilados o cualquier producto comprado "usado" o "tal cual", en una venta de emergencia o de salida de la empresa, o de un liquidador.
3. Boahaus puede requerir una confirmación independiente del defecto reclamado y un comprobante de compra. Las piezas de repuesto estarán garantizadas durante el período restante de la garantía original. BOAHAUS NO TENDRÁ NINGUNA RESPONSABILIDAD POR CUALQUIER DAÑO INCIDENTAL y todos estos daños ESTÁN EXCLUIDOS DE ESTA GARANTÍA, tales como pérdida de uso, desmontaje, transporte, mano de obra o daños a la propiedad en o cerca del producto. Algunos estados no permiten la exclusión o limitación de daños incidentales o consecuentes, por lo que la limitación o exclusión anterior puede no aplicarse a usted.
4. Esta Garantía se aplica únicamente a los defectos garantizados que surgen y se informan a Boahaus dentro del período de cobertura de la garantía. La garantía no puede ser transferida a los propietarios o usuarios posteriores del producto, y será inmediatamente nula en caso de que el producto sea revendido, transferido, arrendado o alquilado a cualquier tercero o persona que no sea el comprador original.
5. NO HAY OTRAS GARANTÍAS APLICABLES A ESTE PRODUCTO. Bajo las leyes de ciertos estados, no puede haber garantías implícitas de Boahaus y todas las garantías implícitas, INCLUYENDO CUALQUIER GARANTÍA IMPLÍCITA DE COMERCIABILIDAD O ADECUACIÓN PARA UN PROPÓSITO EN PARTICULAR, están exoneradas cuando permitido por la ley. TODAS LAS GARANTÍAS IMPLÍCITAS SON APLICABLES, LAS GARANTÍAS IMPLÍCITAS, INCLUIDAS CUALQUIER GARANTÍA IMPLÍCITA DE COMERCIABILIDAD O ADECUACIÓN PARA UN PROPÓSITO PARTICULAR, ESTÁN LIMITADAS EN DURACIÓN A LA DURACIÓN DE ESTA GARANTÍA EXPRESA o el período mínimo permitido por la ley, cualquiera que sea más corto. Algunos estados no permiten limitaciones sobre la duración de una garantía implícita, por lo que es posible que la limitación anterior no se aplique a usted.
6. Para consultas sobre la garantía, preguntas sobre la disposición o reclamaciones, visite nuestro sitio web www.boahaus.com. También puede ponerse en contacto con Boahaus en +1 (787) 688-1254 o por correo electrónico en administracion@boahaus.com. Boahaus puede requerir que los reclamos de garantía sean presentados por escrito a:

Boahaus LLC.
1250-1252
Ave. Franklin Delano Roosevelt,
San Juan, PR 00926.

Incluya su recibo de compra u otra prueba de compra y una descripción específica del defecto del producto.