

boahaus

ASSEMBLY INSTRUCTIONS

ATTENTION!!!

Any inquiry or replacement parts
you need, contact us directly at:

contact@boahaus.com

Scan this QR Code to contact to Customer Support Team.



Or Call Us at +1 281-809-4043

boahaus

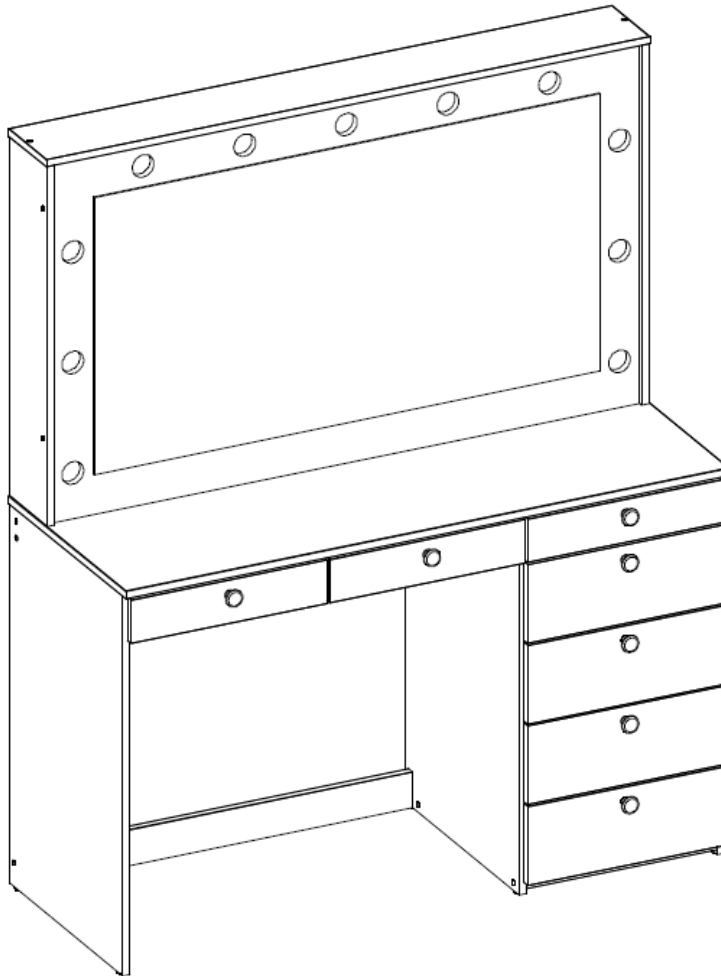
ASSEMBLY INSTRUCTIONS**INSTRUCCIONES DE ARMADO****MODEL #: 1609-L****DRESSING TABLE WITH MIRROR****Tocador con Espejo****Approx. product weight 105.02 lbs. / 47,71 Kg.**

THIS INFORMATION BOOKLET CONTAINS IMPORTANT SAFETY INFORMATION. PLEASE READ AND KEEP FOR FUTURE REFERENCE.
ESTE FOLLETO CONTIENE INFORMACIÓN DE SEGURIDAD IMPORTANTE. POR FAVOR, LEA Y GUÁRDELO PARA REFERENCIA FUTURA.

Need some Help? Call +1 281-809-4043 or email contact@boahaus.com
¿Necesitas ayuda? Llama +1 281-809-4043 o envía un email contact@boahaus.com

GENERAL SAFETY INFORMATION

1. Please read the Assembly Instructions prior to assembling this product.
2. Remove all the hardware from the box and sort by type.
3. Check to see that all the hardware and parts are present BEFORE assembling.
4. To avoid damage, assemble the product on a sturdy, level, and protective surface.
5. Please wait until all steps are completed before fully tightening bolts.
6. Make sure all bolts are tightly fastened before the unit is used.
7. To move the product, you must lift it. DO NOT drag it, if you drag it can cause overturning.
8. **This product is sold with a hardware kit to be fixed on the wall. You must install this kit to prevent any accidents or damages. When properly installed, this restrain can provide protection against the unexpected tipping of the unit due to small tremors, bumps or climbing. The restrain is only a deterrent and is not a substitute for proper adult supervision. Use of tip-over restraints may only reduce, but not eliminate, the risk of tip-over**

INFORMACIÓN GENERAL DE SEGURIDAD

1. Lea las instrucciones de armado antes de ensamblar este producto.
2. Extraiga todo el hardware de la caja y ordene por tipo.
3. Verifique que todo el hardware y las piezas están presentes ANTES de ensamblar.
4. Para evitar daños, ensamble el producto sobre una superficie resistente, nivelada y con protección.
5. Espere hasta que todos los pasos se hayan completado antes de apretar completamente los tornillos y accesorios.
6. Asegúrese de que todos los tornillos y accesorios estén bien apretados antes de usar la unidad.
7. Para mover el producto debe levantarlo. NO lo arrastre, si lo arrastra puede causar volcamiento.
8. **Este producto se vende con un kit de accesorios para ser fijado en la pared. Debe instalar este kit para evitar accidentes o daños. Cuando se instala correctamente, esta restricción puede proporcionar protección contra la inclinación inesperada de la unidad debido a temblores pequeños, golpes o al treparse. La restricción es solo un elemento disuasivo y no es un sustituto de la supervisión adecuada de un adulto. El uso de restricciones de vuelco solo puede reducir, pero no eliminar, el riesgo de volcarse.**



General Dimensions / Dimensiones Generales

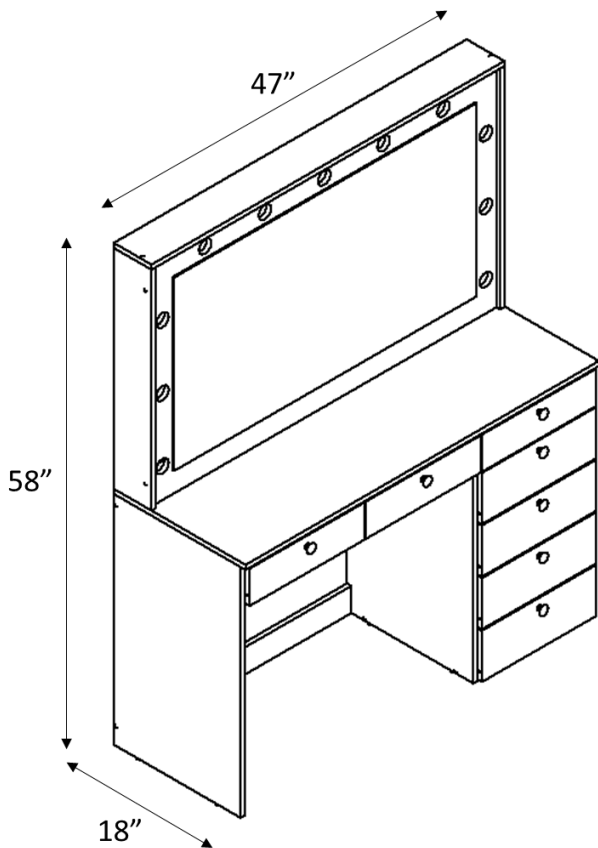

Maximum weight supported / Peso máximo soportado

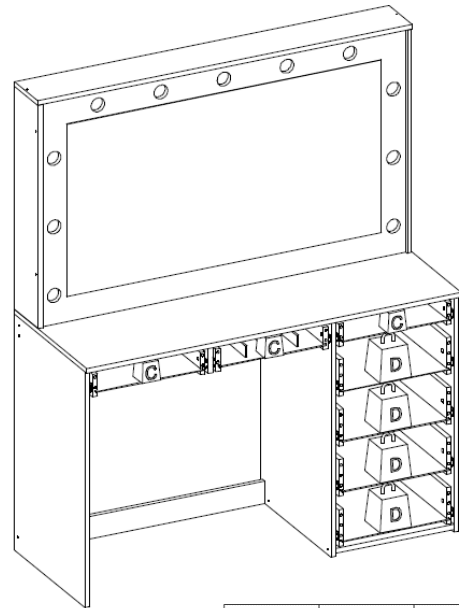

	LB	KG
C	6	3
D	11	5

Weight in pounds. / Peso en libras.

Note: weight must be evenly distributed.
Nota: el peso debe estar distribuido uniformemente.

You will need / usted necesitará:

Tools not included / herramientas no incluidas



2 people
2 personas

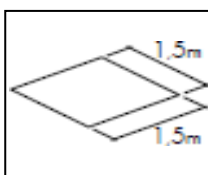

Recommended space for assemble
Espacio recomendado para el armado

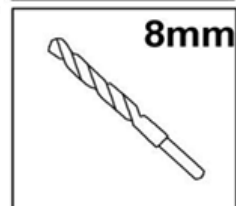
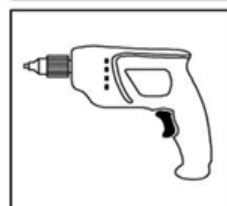
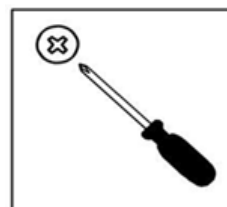

Note: Place a carpet or blanket in the assembly area to avoid damage to the parts during the process.
Nota: Colocar una alfombra o manta en el area de armado para evitar daños en las piezas durante el proceso.





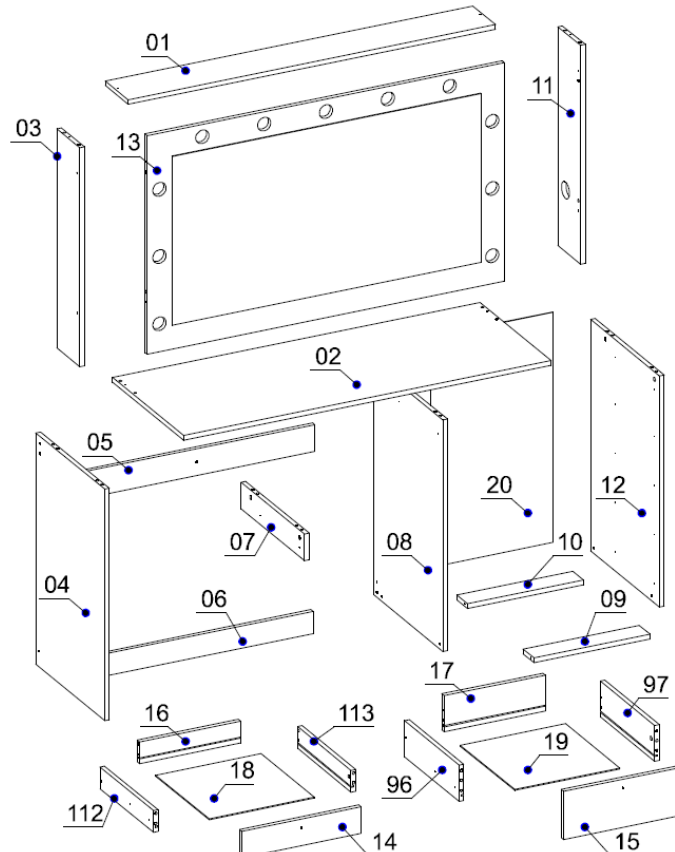











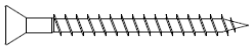

PARTS IDENTIFICATION / IDENTIFICACION DE PARTES



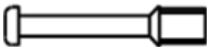

Nº	DESCRIPTION - DESCRIPCIÓN	QTY.
1	Top tray / Travesaño superior	1
2	Top base / Base superior	1
3	Left Side tray / Travesaño lateral izquierdo	1
4	Left side / Lateral izquierdo	1
5	Crossbeam / Travesaño	1
6	Large footer / Zócalo grande	1
7	Drawer divider support / Divisoria soporte cajón	1
8	Division / División	1
9	Small footer 1 / Zócalo pequeño 1	1
10	Small footer 2 / Zócalo pequeño 2	1
11	Right side tray / Travesaño lateral derecho	1
12	Right side / Lateral derecho	1
13	Mirror / Espejo	1
14	Front of small drawer / Frontal de cajón pequeño	3
15	Front of large drawer / Frontal de cajón grande	4
16	Rear of small drawer / Posterior de cajón pequeño	3
17	Rear of large drawer / Posterior de cajón grande	4
18	Bottom of small drawer / Fondo de cajón pequeno	3
19	Bottom of large drawer / Fondo de cajón grande	4
20	Backboard / Fondo	1
96	Left side of large drawer / Lateral izquierdo de cajón grande	4
97	Right side of large drawer / Lateral derecho de cajón grande	4
112	Left side of small drawer / Lateral izquierdo de cajón pequeno	3
113	Right side of small drawer / Lateral derecho de cajón pequeno	3

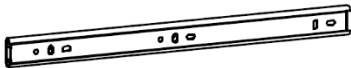

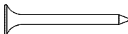
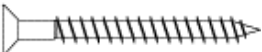
Need some Help? Call +1 281-809-4043 or email contact@boahaus.com
 ¿Necesitas ayuda? Llama +1 281-809-4043 o envía un email contact@boahaus.com

IDENTIFICATION OF ACCESSORIES / IDENTIFICACION DE ACCESORIOS

NUMBER		DESCRIPTION	QTY
A		Flanged head screw / Tornillo cabeza flangeada (5 x 60 mm)	1
A1		Glue / Pegamento	1
A2		Small plastic foot / Pie plástico	6
A3		Trapeze / Trapecio	6
B3		Bushing / Bushing	1
B5		Metallic angle plates / Soporte de metal	2
D		Flat head screw / Tornillo cabeza plana (4 x 40 mm)	1
E		Wooden dowel / Pin (8 x 30 mm)	62
E9		Strap / Correa	1
F		Wooden dowel / Pin (8 x 50 mm)	2
G		Structural screw / Tornillo estructural (5 x 50 mm)	16
H		Allen key / Llave allen	1
H18		Handle / Tirador	7
I		Structural screw cover / Tapa de tornillo estructural	12
J		Simple minifix screw / Tornillo minifix simple	16
L		Drum lock / Tambor minifix	16
L9		Flat head screw / Tornillo cabeza plana (3,5 x 14 mm)	56
L17		Telescopic slides / Correderas telescópicas	14
M		Adhesive bore patch / Tapón adhesivo	8
N		Nail / Clavo (10x10mm)	28
O		Flat head screw / Tornillo cabeza plana (4.5 x 45mm)	14

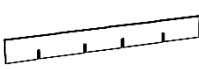
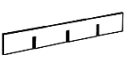
P		Pan head screw / Tornillo cabeza pan (4.5 x 25mm)	6
S		Pan head screw / Tornillo cabeza pan (3.5 x 14mm)	9
T		Flanged head screw / Tornillo cabeza flangeada (4,0 x 30 mm)	7
Z		Plastic hole plugs / Tapon plastic	1
Z11A		Drawer Organizer A / Organizador de gaveta A	2
Z11B		Drawer Organizer B / Organizador de gaveta B	3



ATTENTION

To facilitate the assembly process, separate and organize all boards before you start.

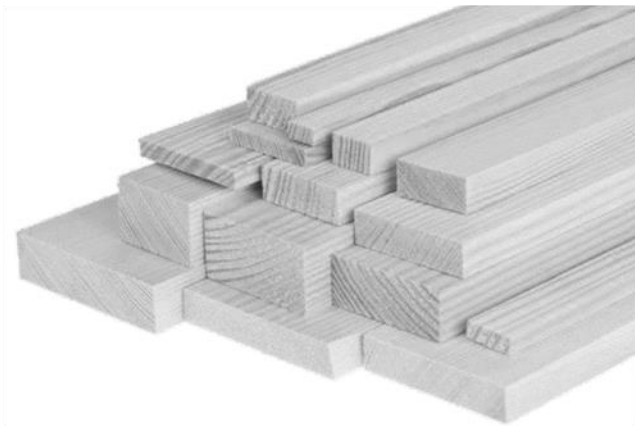

Para facilitar el armado, separa y organiza todas las tablas antes de empezar.

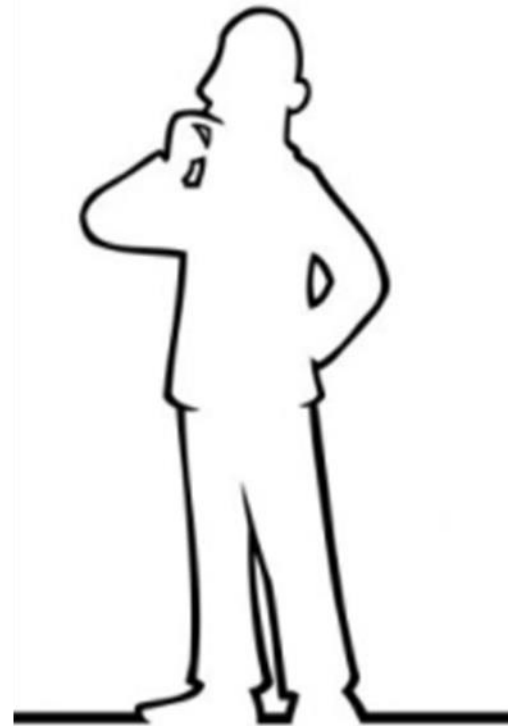

PRE-ASSEMBLY / PRE- ARMADO

- 1** Fix *wooden dowel* (E) to *crossbeam* (5) and *large footer* (6).
 Fijar pin (E) a *travesaño* (5) y *zócalo grande* (6).

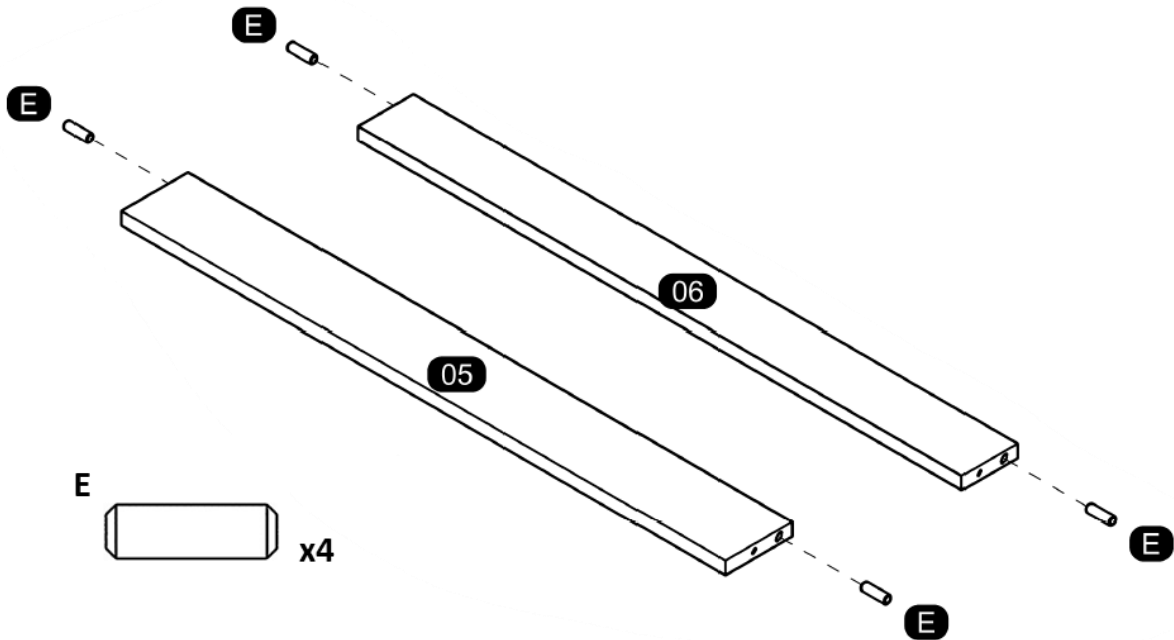

- 2** Fix *simple minifix screw* (J) to *top base* (2).
 Fijar *tornillo minifix simple* (J) a *base superior* (2).

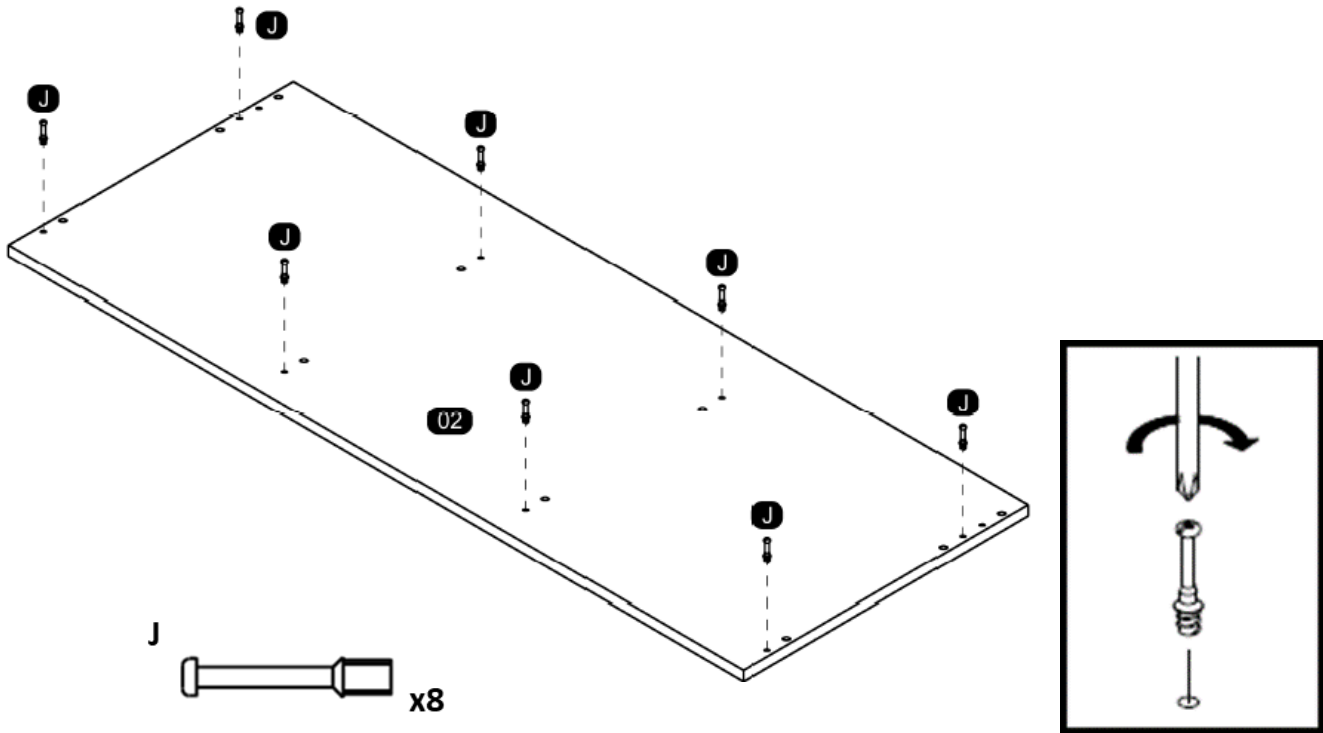

SEPARATE THE TWO PARTS OF THE METAL SLIDE TO THE ASSEMBLY FOLLOWING THE INSTRUCTIONS BELOW.
 SEPARARE AS DUAS PARTES DA CORREDIÇA METÁLICA PARA A MONTAGEM SEGUINDO AS INSTRUÇÕES ABAIXO.
 SEPARAR LAS DOS PARTES DE LA CORREDERA DE METAL PARA EL ARMADO Y SEGUIR LAS INSTRUCCIONES ABAJO

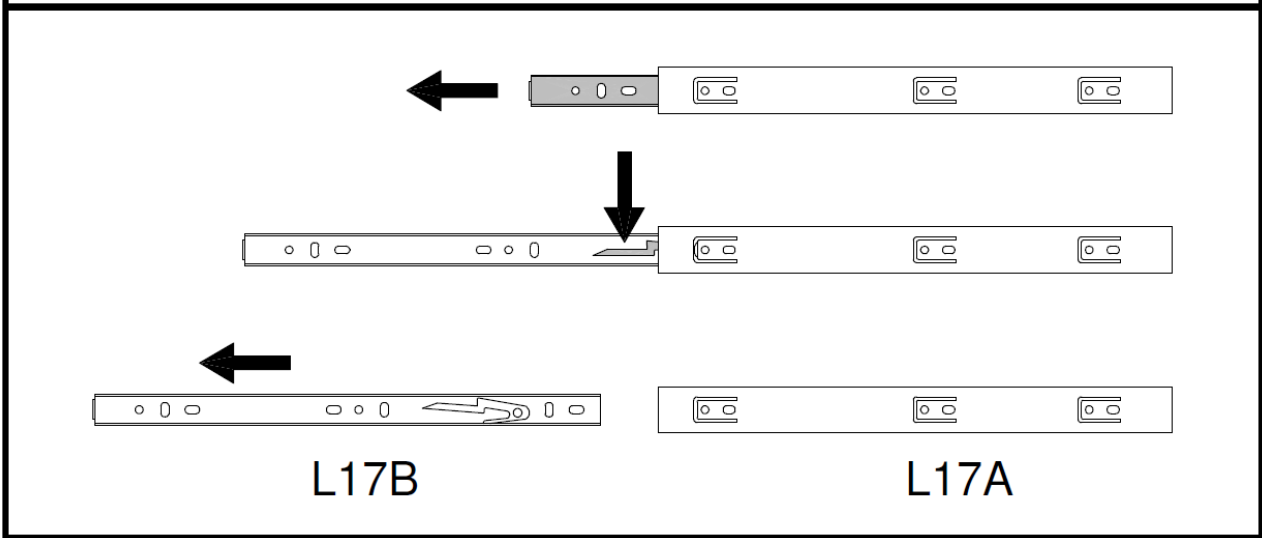

3

Fix **wooden dowel** (E) and (F), **metallic slide** (L17A) to **left side** (4).

Fijar **pin** (E) y (F), **corredera lateral** (L17A) a **lateral izquierdo** (4).

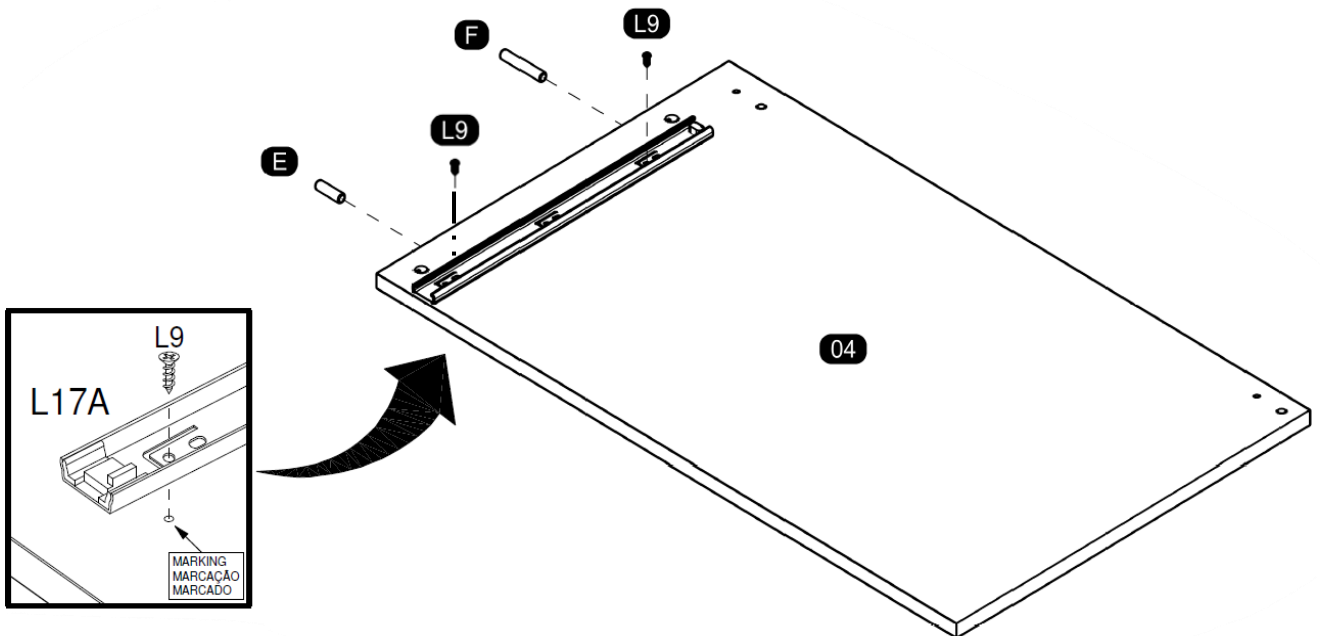

- 4** Fix **wooden dowel (E)** to **sides of drawer (96/97) x4** and **side drawer (112/113) x3**
 Fije **pin (E)** al **lateral del cajón grande (96/97) x4** y al **lateral del cajón pequeño (112/113) x3**

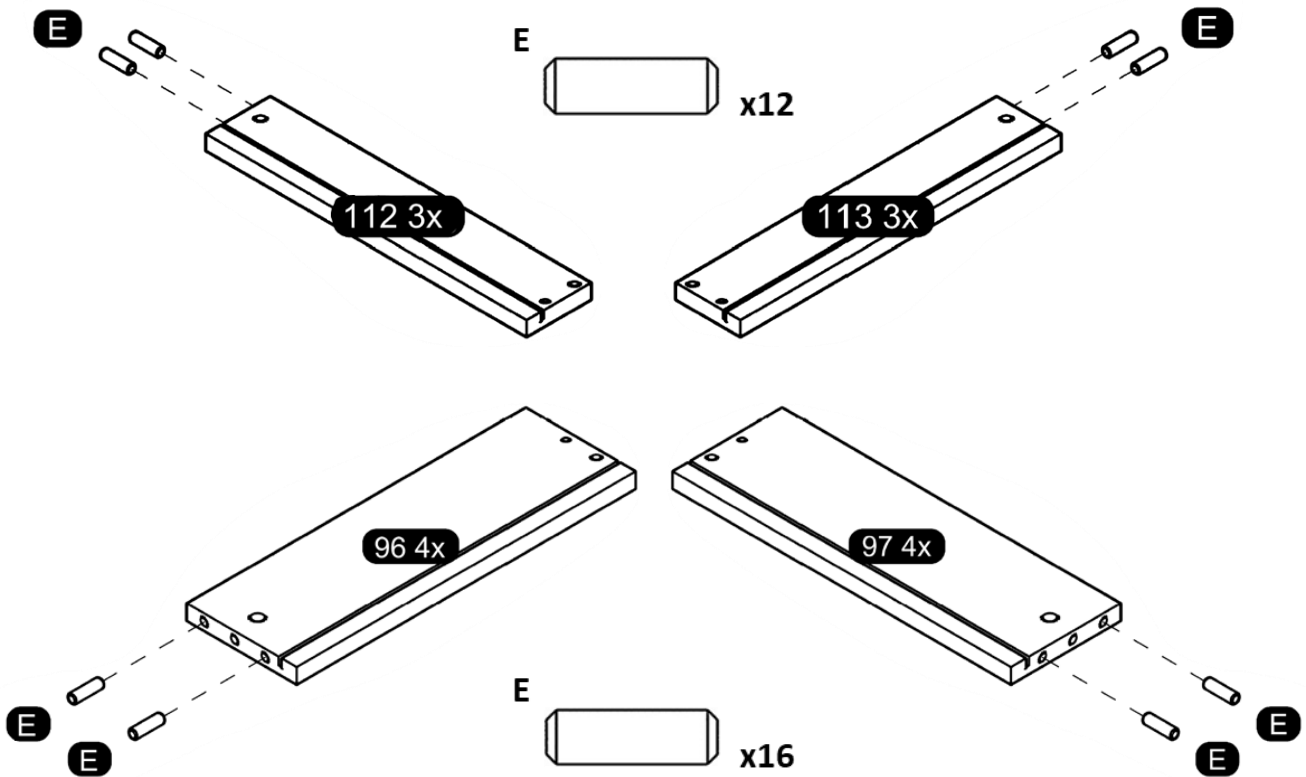

- 5** Fix **wooden dowel (E)** to **rear of large drawer (17)x4** and **rear of small drawer (16)x3**
 Fije el **pin (E)** al **posterior de cajón grande (17)x4** y al **posterior de cajón pequeño (16)x3**

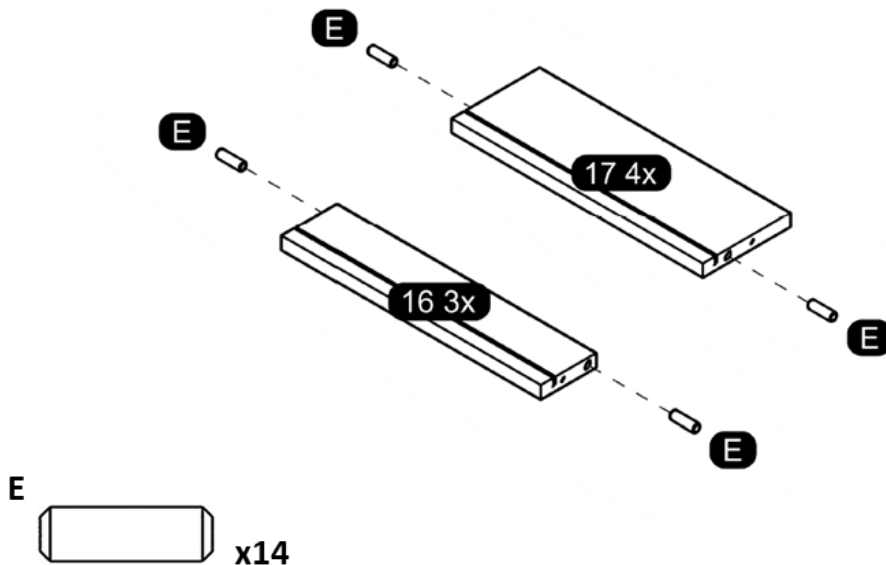

6 Fix *simple minifix screw* (J) and *knob* (H18) to *front of large drawer* (15) x4 and *front of small drawer* (14) x3.

Fijar *tornillo minifix simple* (J) y *tirador* (H18) a *frente de cajón grande* (15) x4 y *frente de cajón pequeño* (14) x3

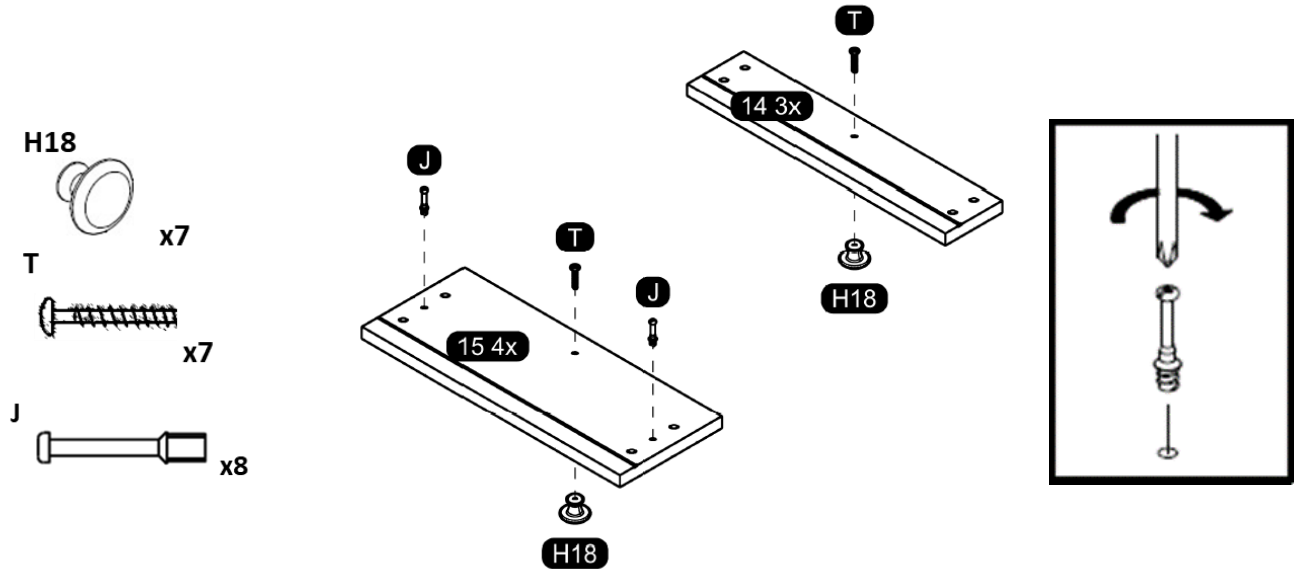

7 Fix *metallic slide* (L17A) and *wooden dowel* (E) to *drawer divide support* (07). Flip *drawer divide support* (07) and fix *metallic slide* (L17A).

Fijar *corredera lateral* (L17A) y *pin* (E) a *divisoria soporte cajón* (07). Voltrear *divisoria soporte cajón* (07) y fijar *corredera lateral* (L17A).

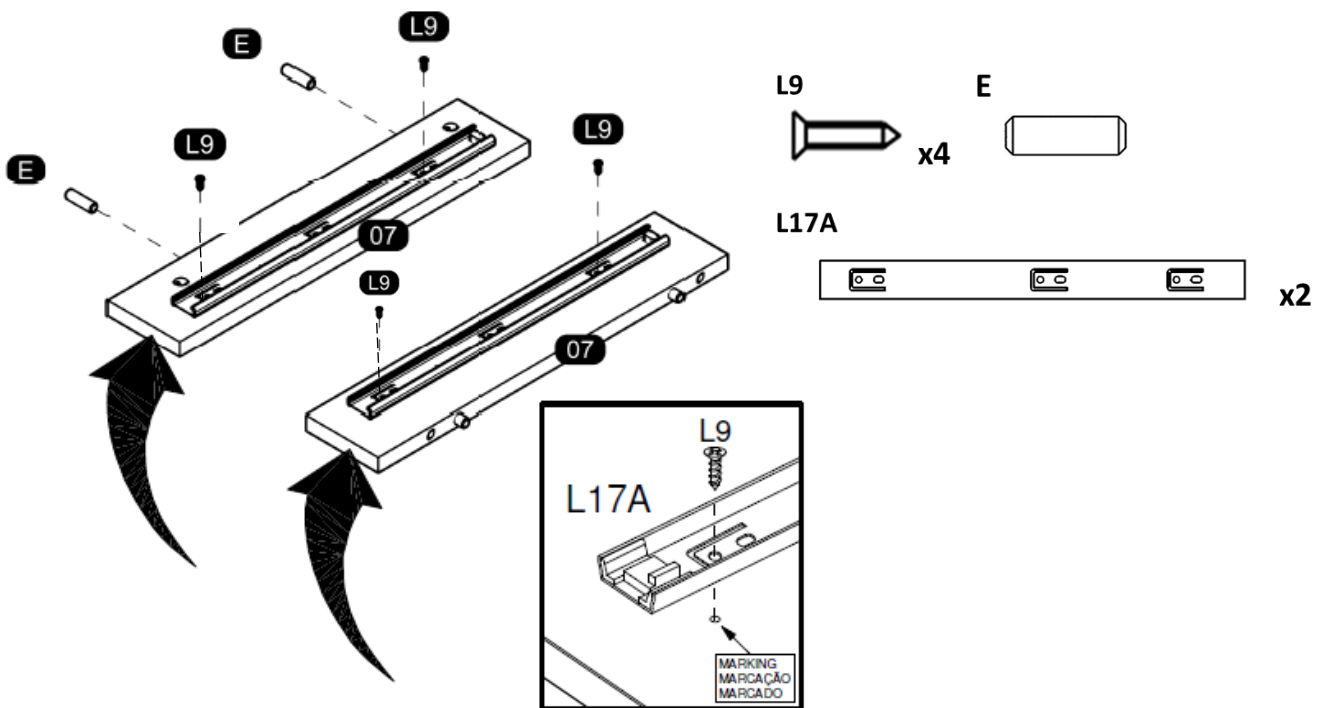

8 Fix **wooden dowel** (E) to **left-side tray** (3) and **right-side tray** (11)
 Fijar **pin** (E) a **travesaños laterales** (3) y (11)

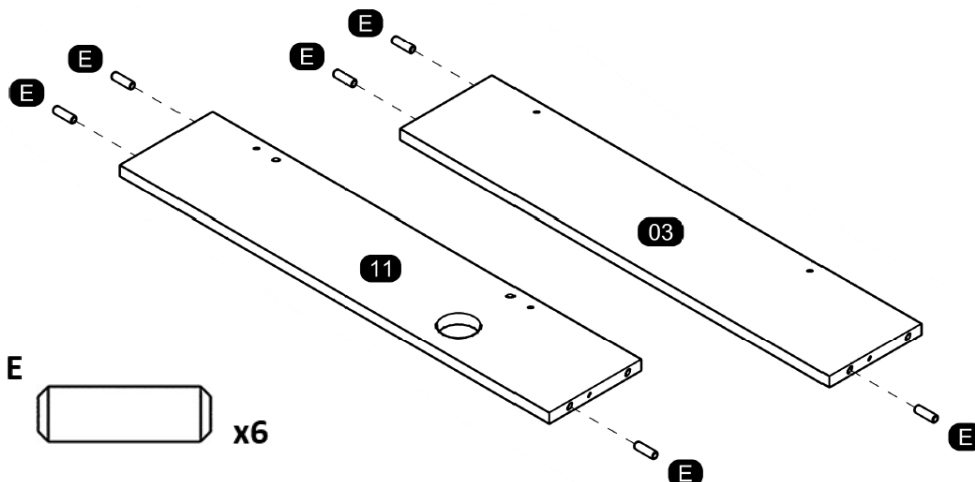

9 Fix **wooden dowel** (E) and (F) and **metallic slide** (L17A) to **right side** (12).
 Fijar **pin** (E) y (F) y **corredera lateral** (L17A) a **lateral derecho** (12).

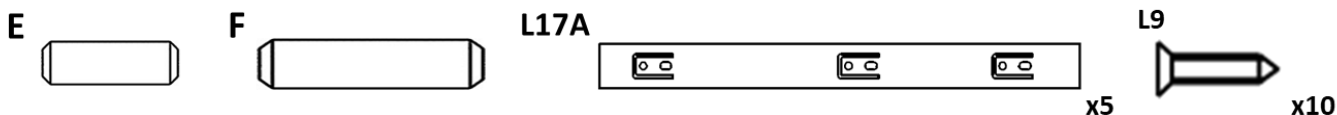
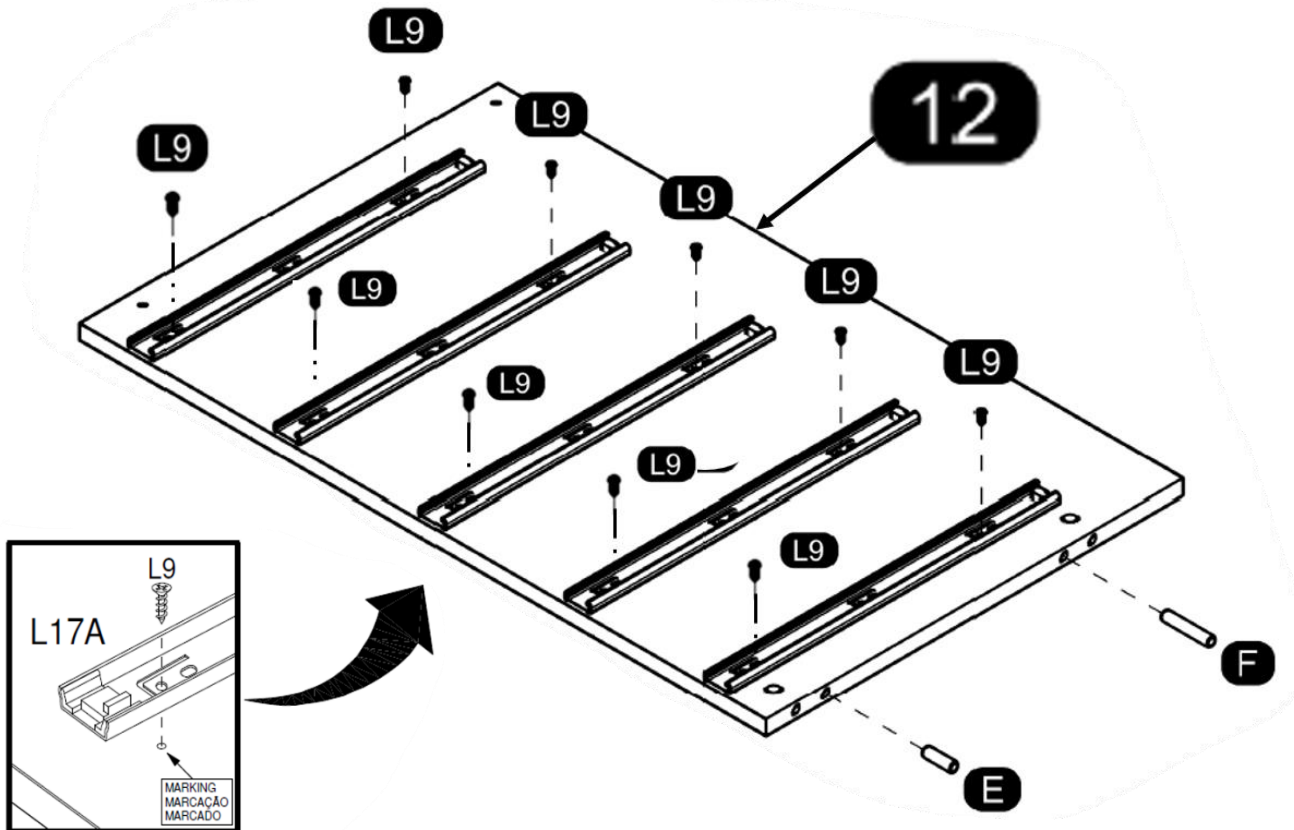

10

Fix **metallic slide** (L17A) and **wooden dowel** (E) to **division** (08). Flip **division** (08) and fix **metallic slide** (L17A).

Fijar **corredera lateral** (L17A) y **pin** (E) a **división** (08). Voltear **división** (08) y fijar **corredera lateral** (L17A).

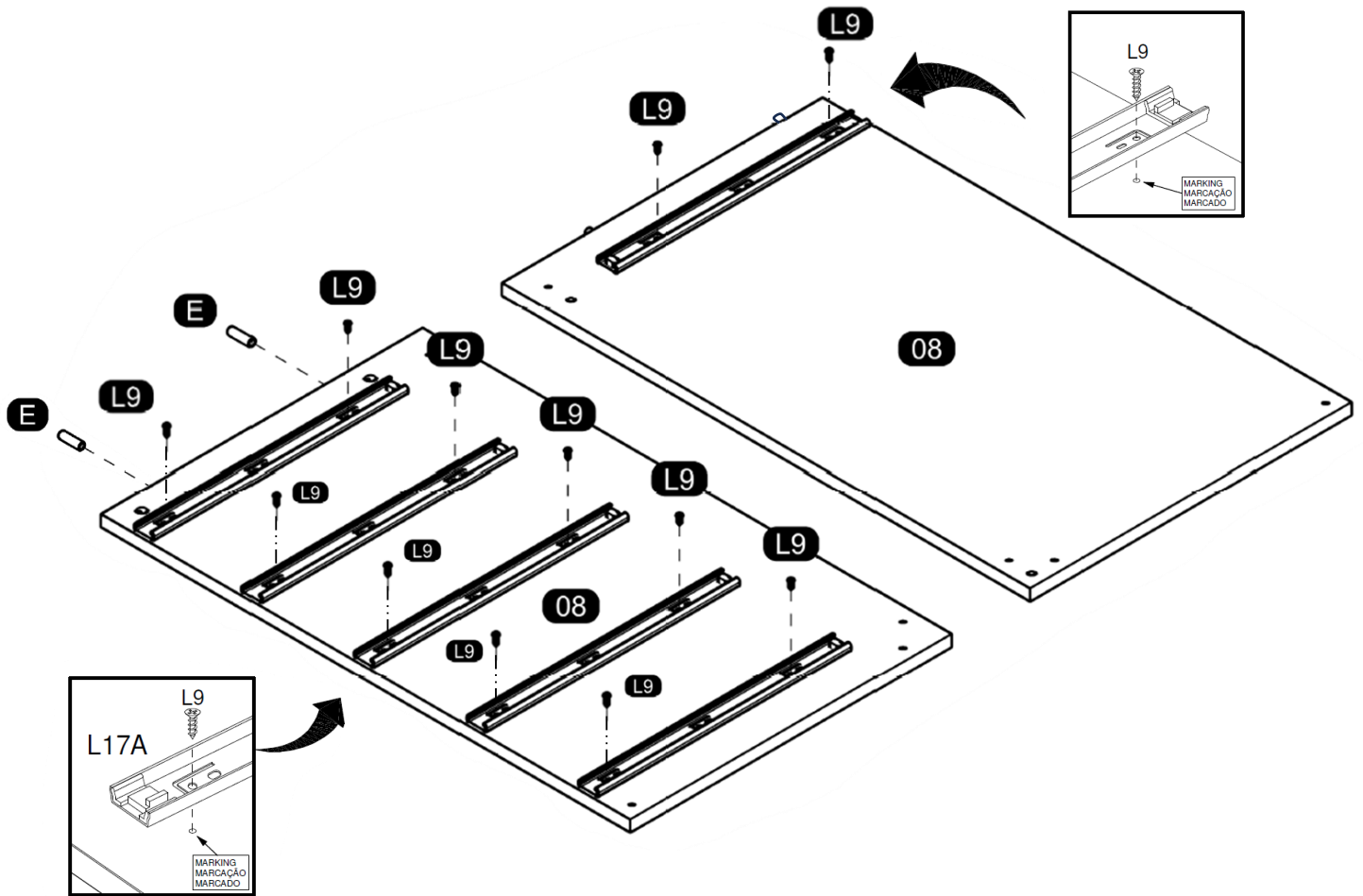

E



L17A



x6

L9



x12

11

Fix *wooden dowel* (E) to *mirror* (13)
Fijar *pin de madera* (E) al *espejo* (13)

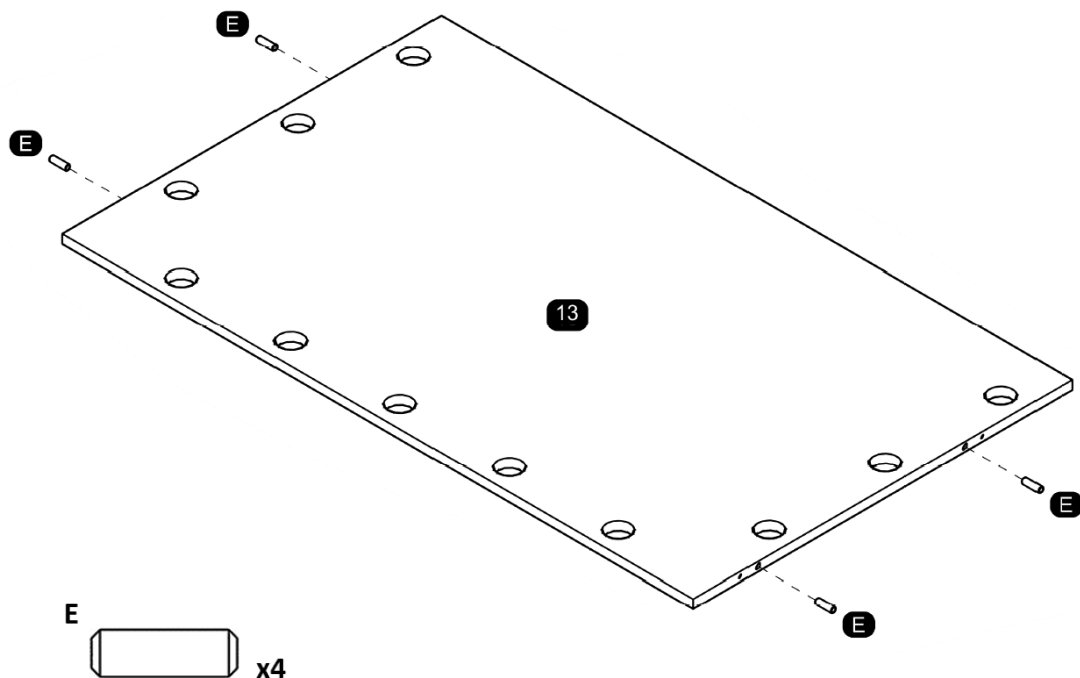

12

Fix *left side tray* (3) and *right-side tray* (11) to *mirror* (13).

Fijar *travesaño lateral izquierdo* (3) y *travesaño lateral derecho* (11) a *espejo* (13).

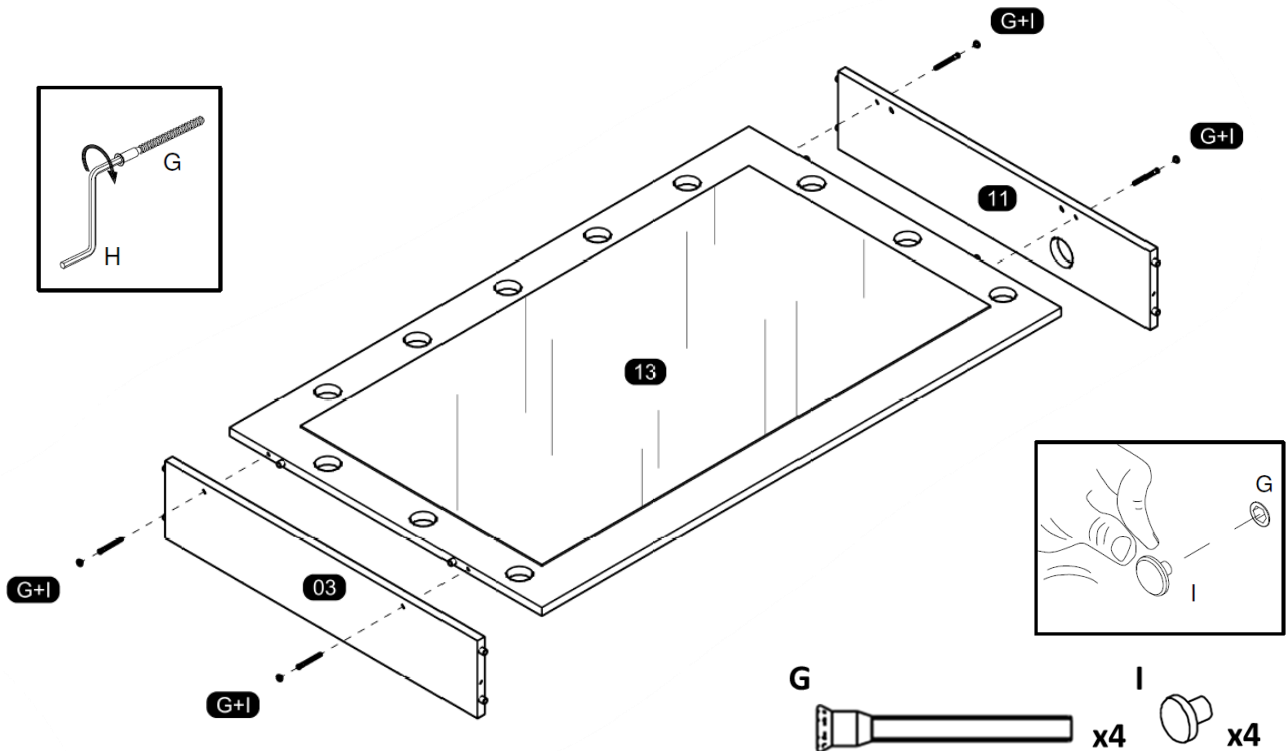

13

Fix *top tray* (1) and *top base* (02) to previous assembly.

Fijar *travesaño superior* (1) y *tope* (02) a ensamble previo.

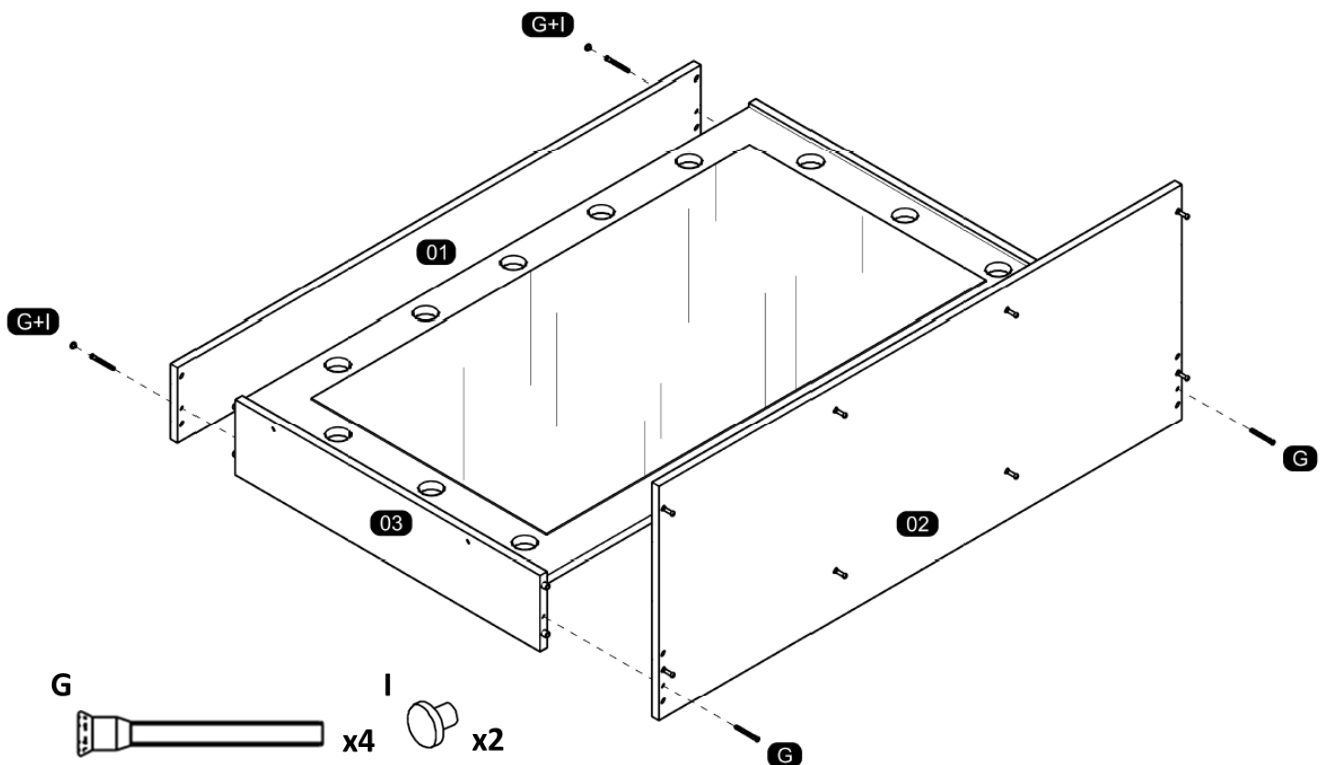

14 Fix *crossbeam* (5) and *large footer* (6) to *left side* (4) and *division* (8).
 Fijar *travesaño* (5) y *zócalo grande* (6) a *lateral izquierdo* (4) y *división* (8).

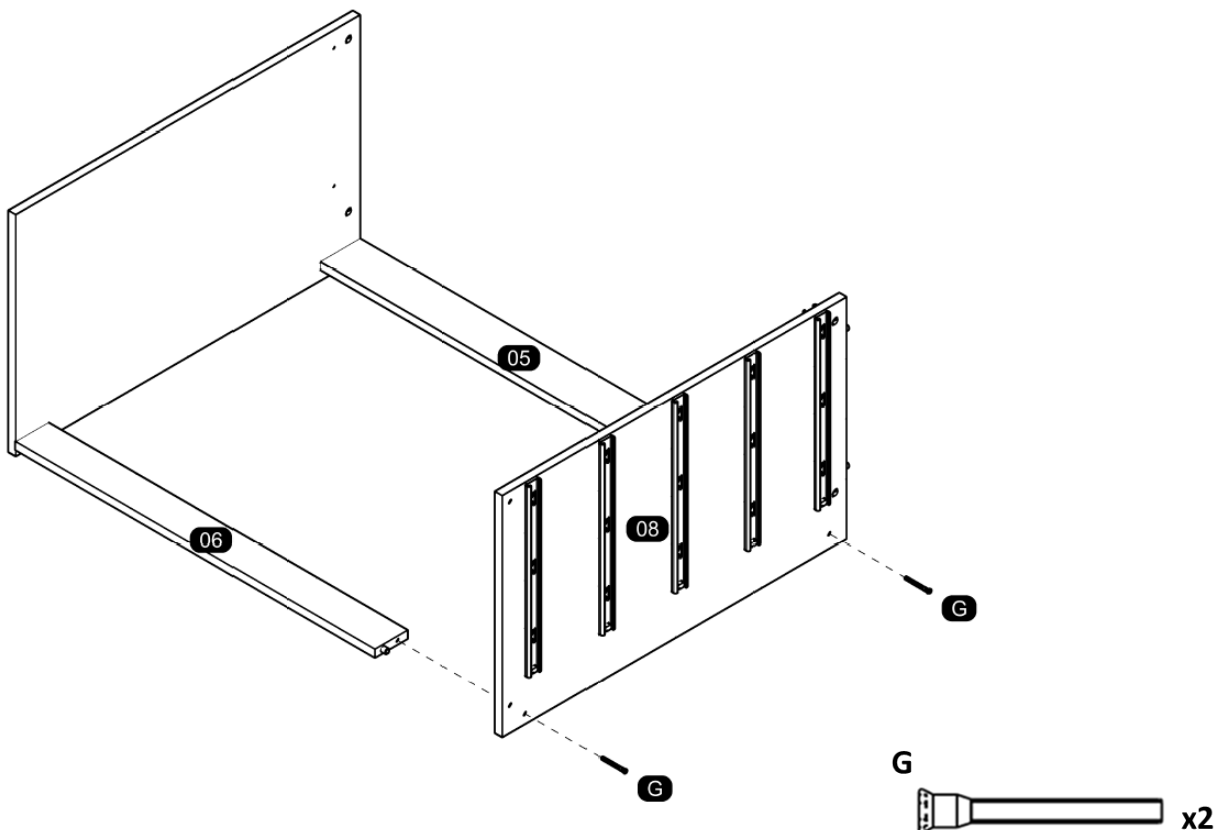
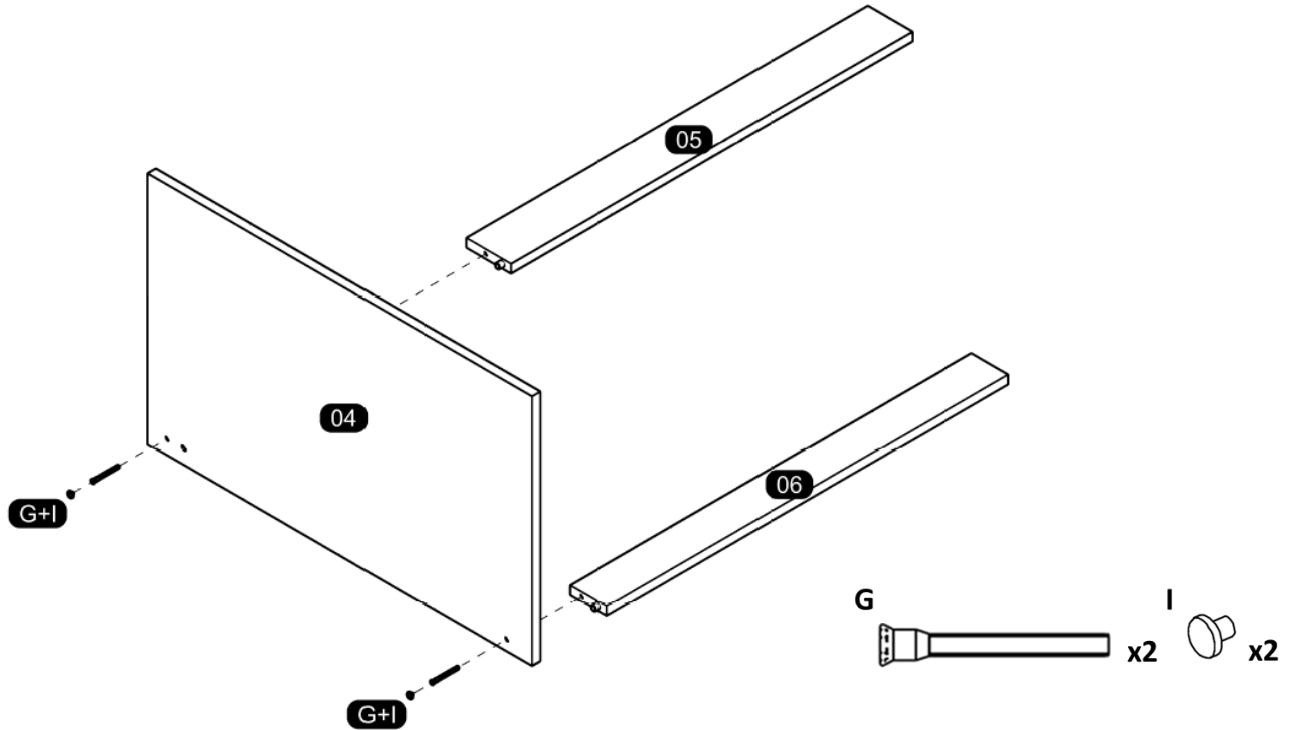

15

Fix *small footer* (09) and (10) and *right side* (12) to previous assembly.
 Fijar *zócalo pequeño* (09) y (10) y *lateral derecho* (12) a ensamble previo.

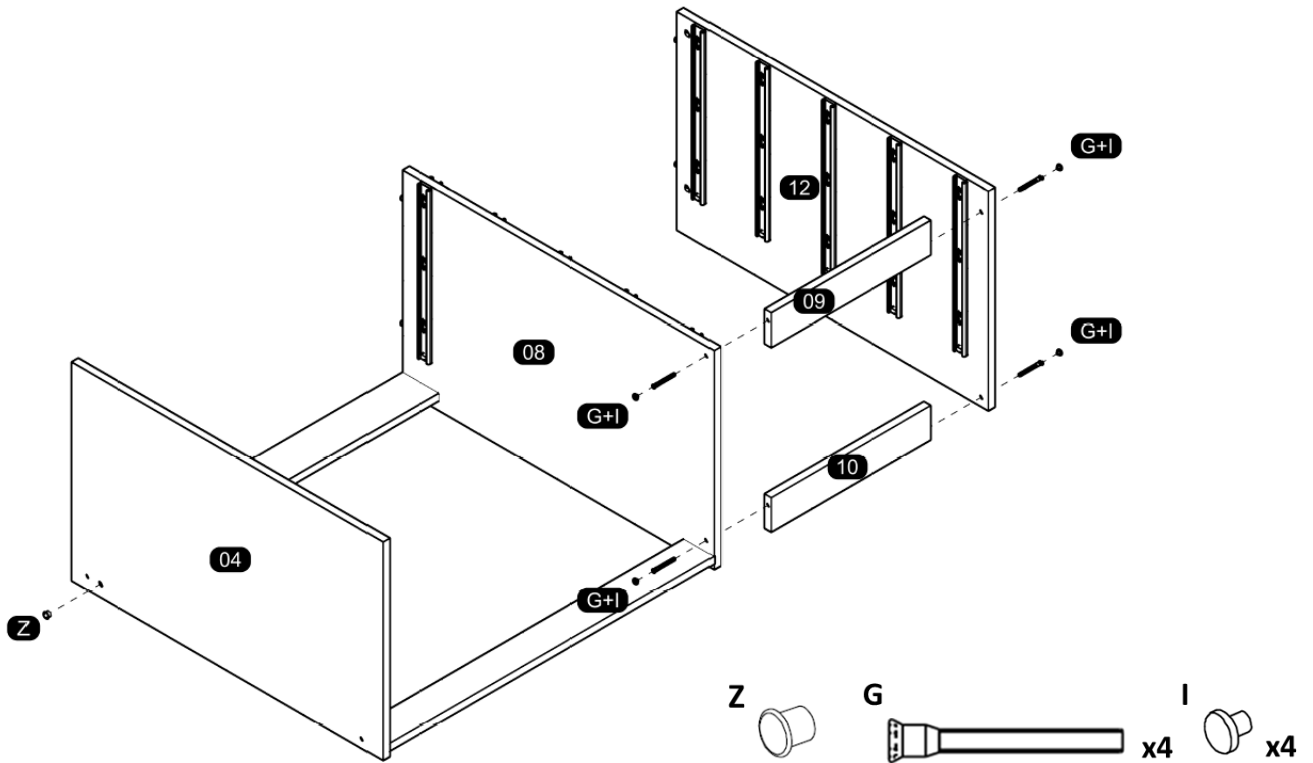

16

Fix both previous assemblies (13 and 15).
 Fijar ambos ensambles previos (13 y 15).

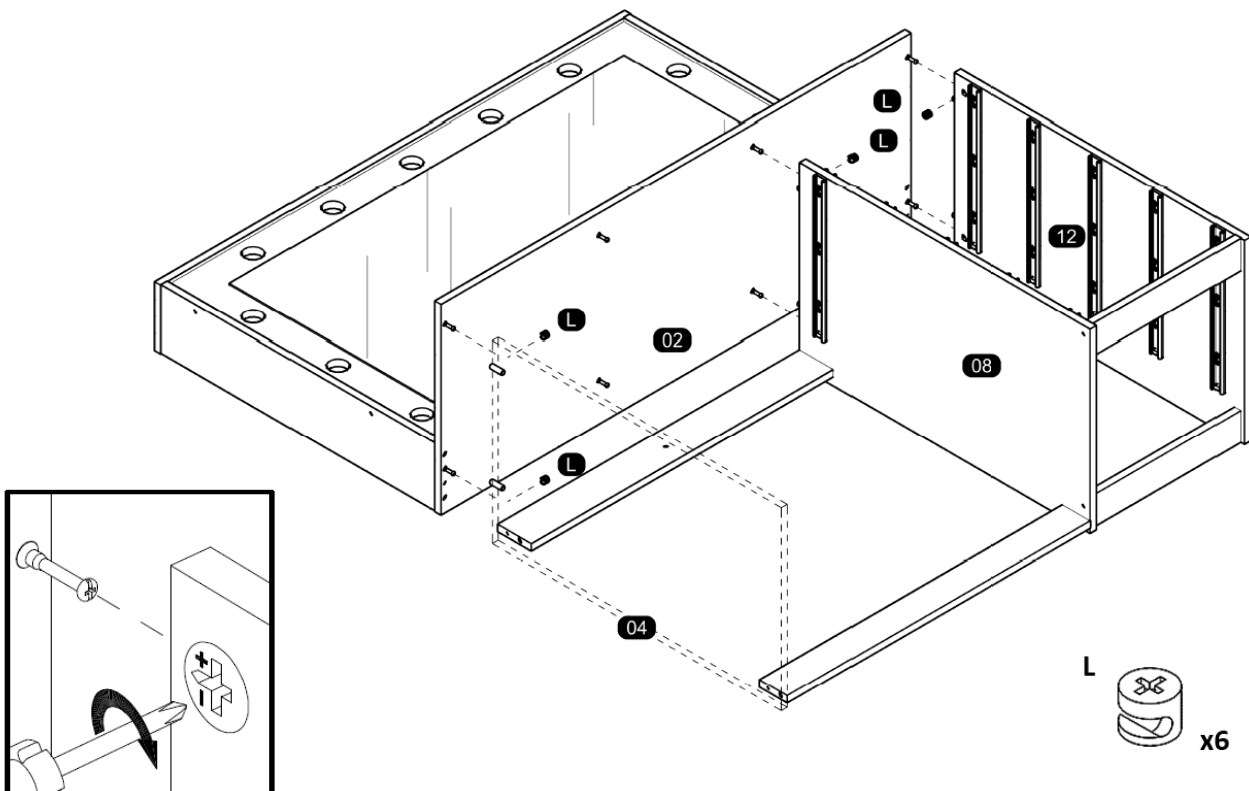

17

Fix Drawer divider (07) to previous assembly
Fijar divisor de gavetas (07) al ensamble previo.

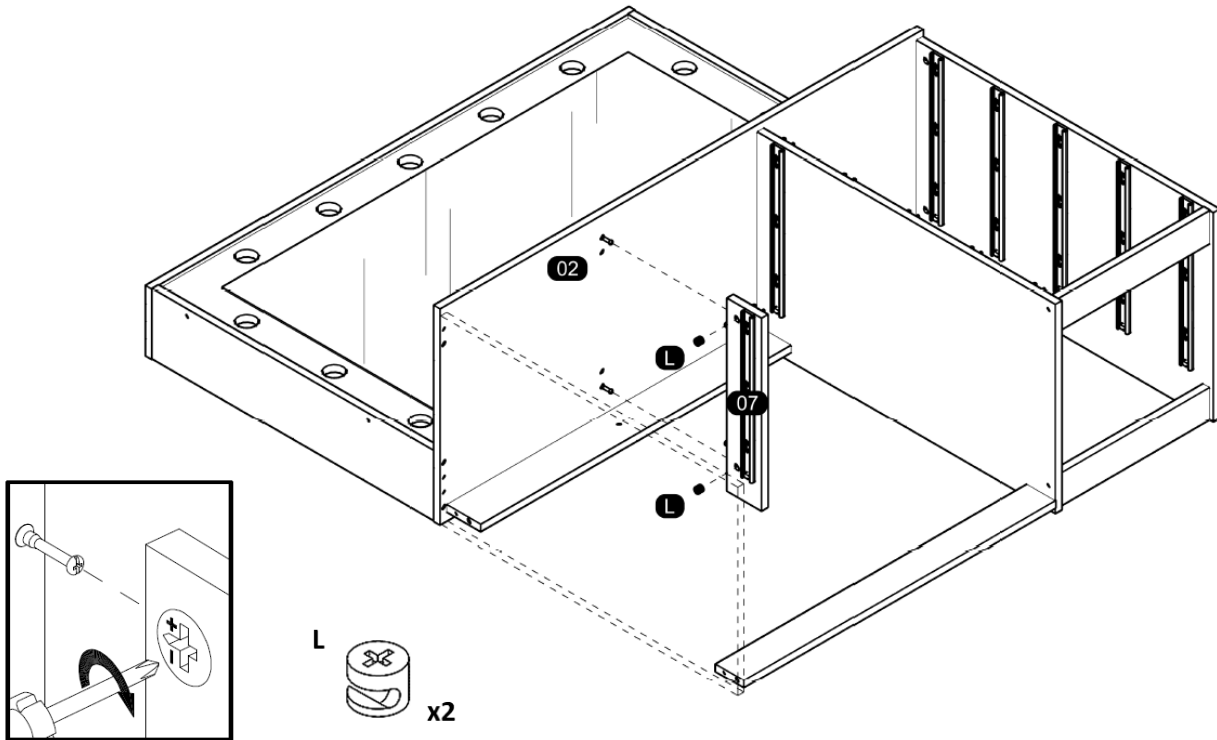

18

Fix plastic foot (A2) to previous assembly.
Fijar pie plástico (A2) a ensamble previo.

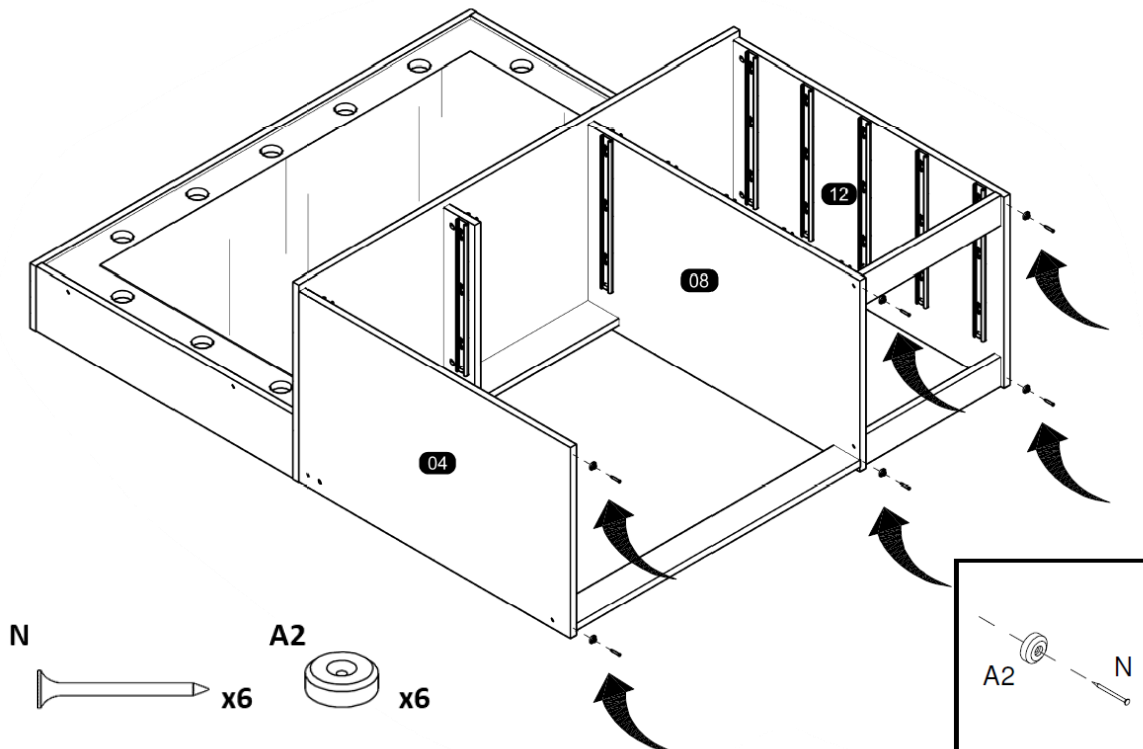

19

Fix **backboard** (20) and fix screw D to crossbeam (5) to previous assembly.
 Fijar **fondo** (20) y fije el tornillo D al travesaño (5) a ensamble previo.

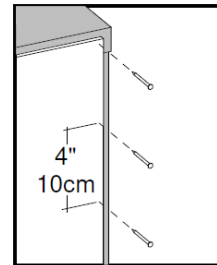
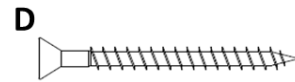
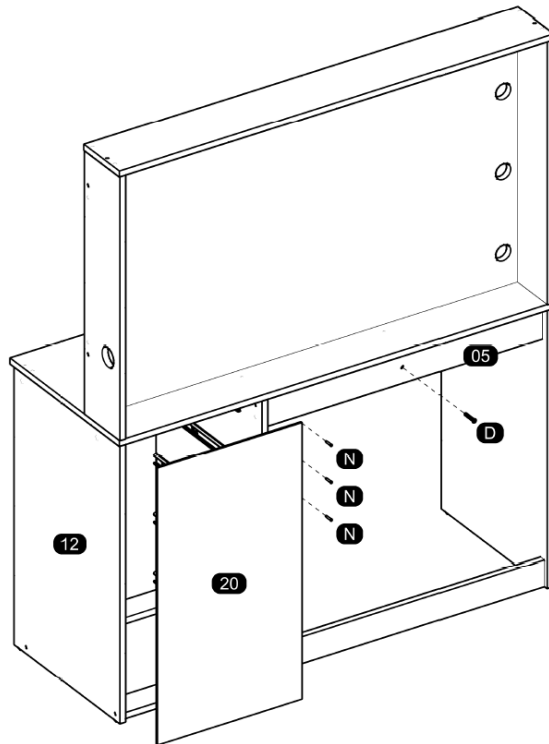

20

Fix angle plates (B5) to previous assembly.
 Fije los ángulos metálicos (B5) al ensamble previo

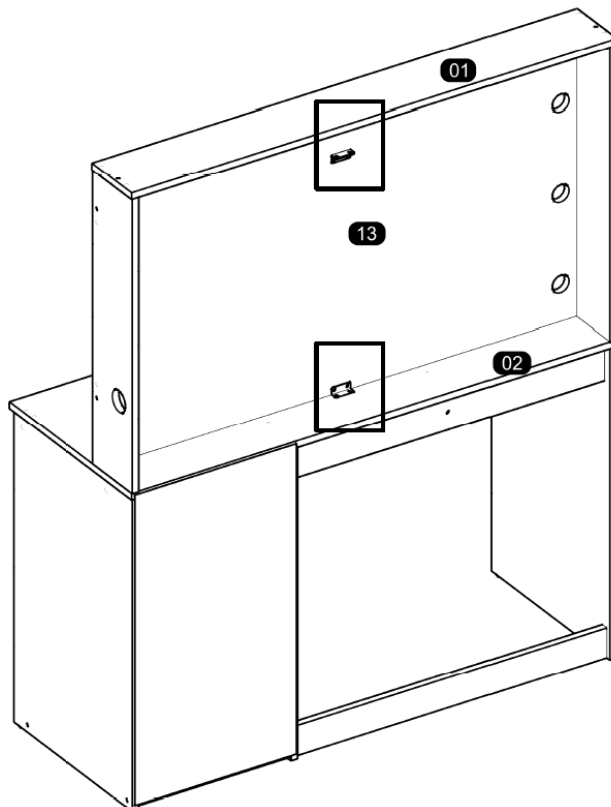

Note: these holes ARE NOT PRE-DRILLED and must be made with the screwdriver and the corresponding screw.

Nota: estos agujeros NO ESTAN PRE-HECHOS y deben hacerse con el destornillador y el tornillo correspondiente.

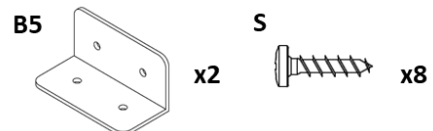
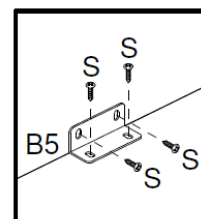

21

Fix *side of drawer* (96/97) and *bottom of drawer* (19) to *rear of drawer* (17)
 Fijar *lateral de cajón central* (96/97) y *fondo de cajón* (19) a *trasero de cajón* (17)

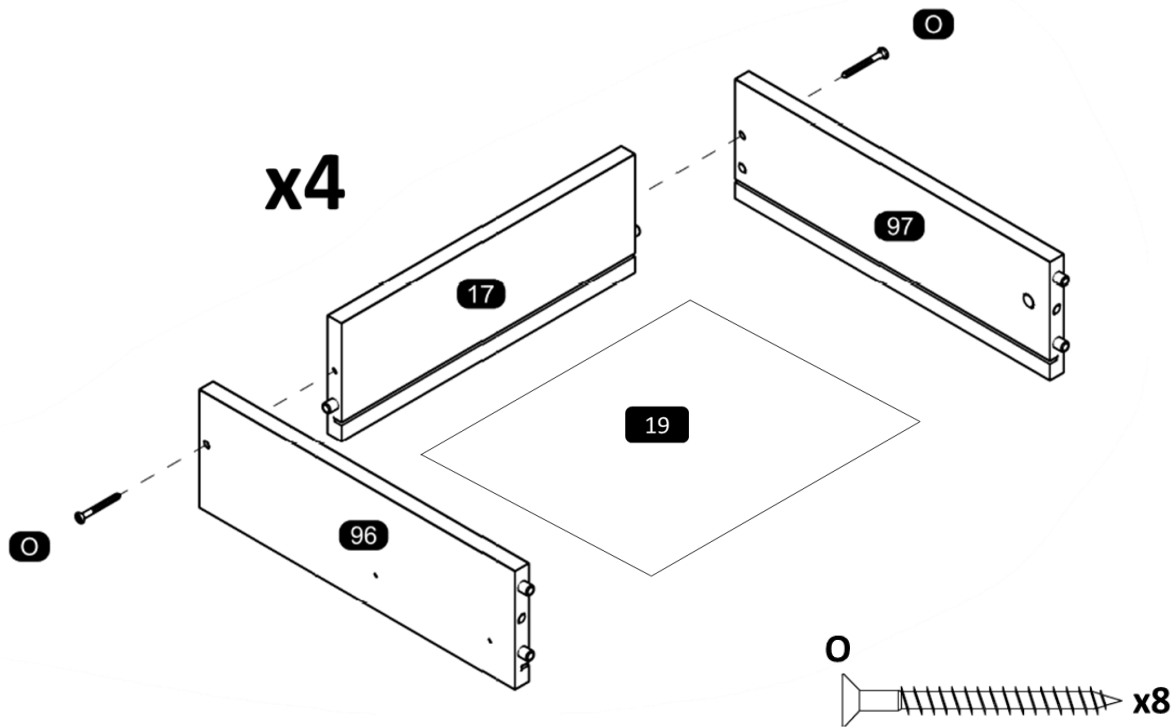

22

Fix *front large drawer* (15) x4 to previous assembly.
 Fijar *frente del cajón grande* (15) x4 a ensamble previo.

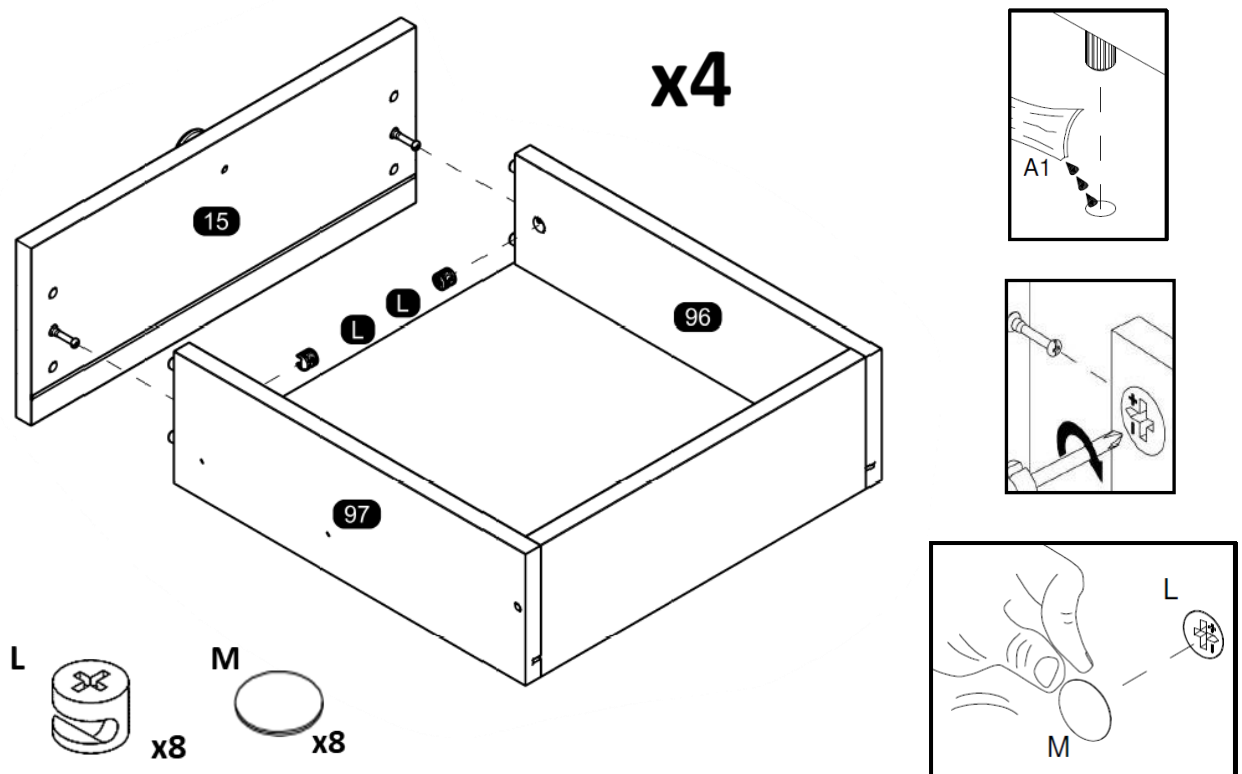

23

Fix **drawer slide** (L17B) x8 to large drawer x4.
 Fijar **corredera de cajón** (L17B) a cajón grande x4.

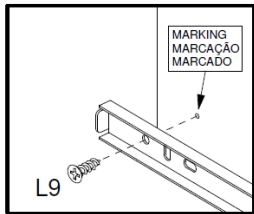
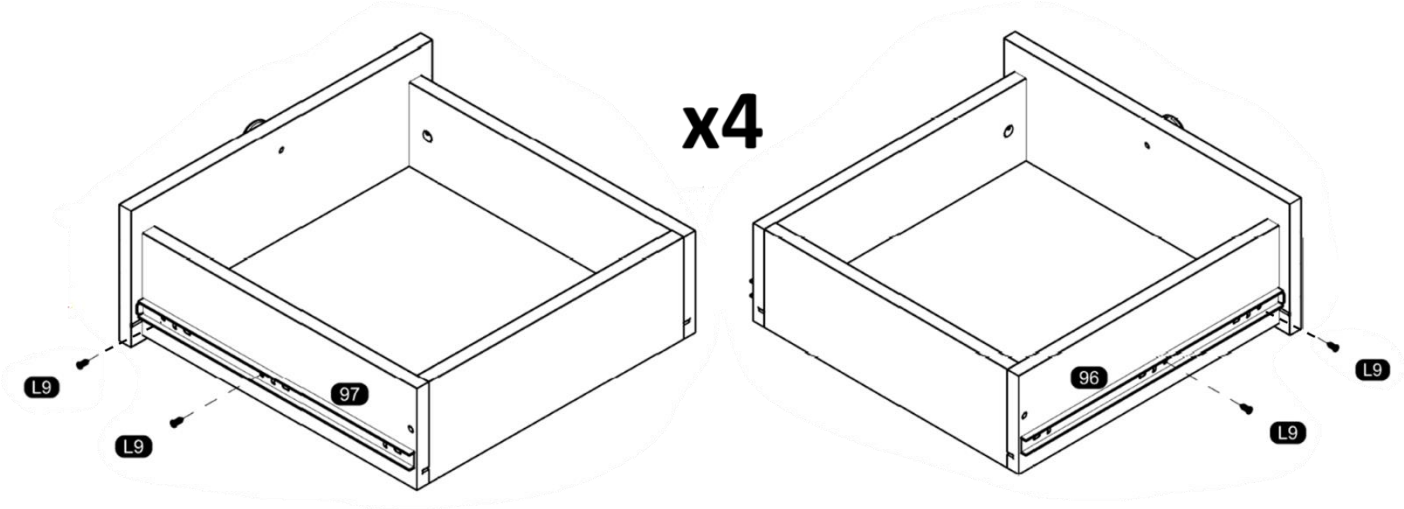

L17B



x8

L9



x16

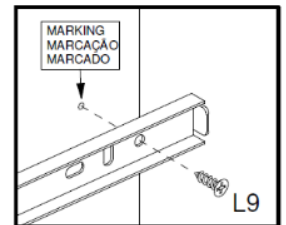

24

Fix side of the **small drawer** (112/113) x6 to the **rear of the small drawer** (16) x3.
 Fije el lateral del **cajón pequeño** (112/113) x6 en la parte posterior del **cajón pequeño** (16)x3

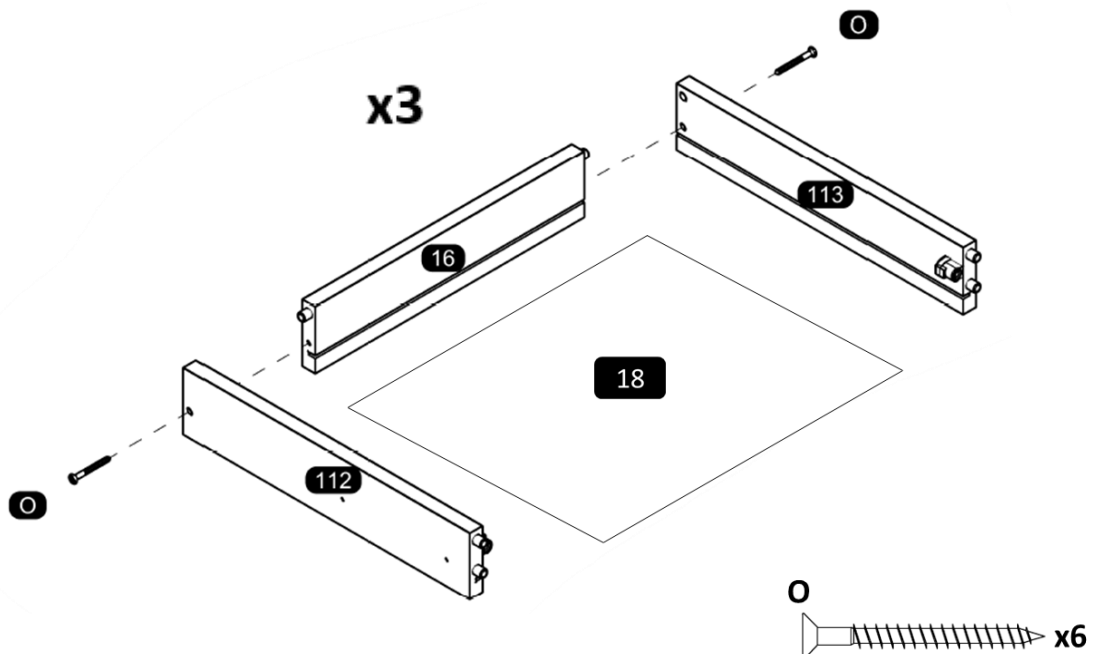

25

Fix **front of small drawer** (14) x3 to previous assembly.
 Fijar **frente de cajón pequeño** (14) x3 a ensamble previo.

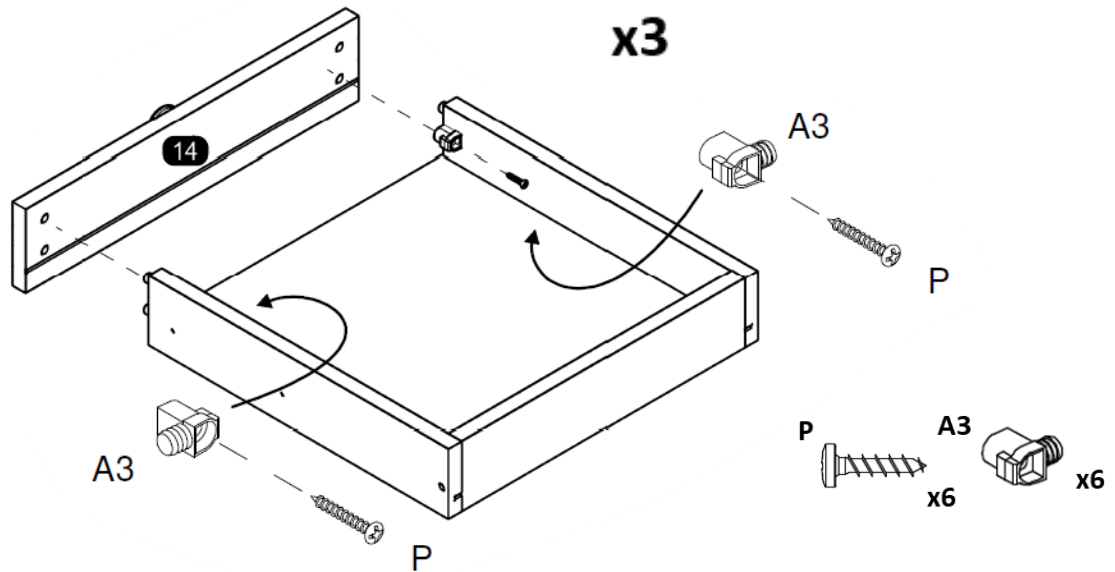

26

Fix **drawer slide** (L17B) x6 to small drawer x3.
 Fijar **corredera de cajón** (L17B) x6 a cajón pequeño x3.

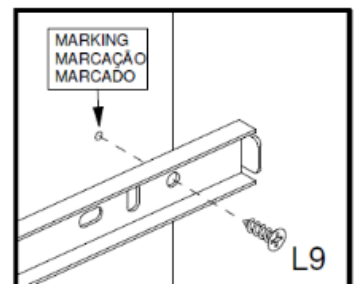
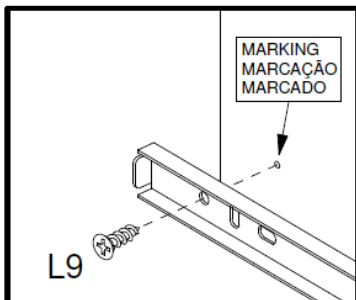
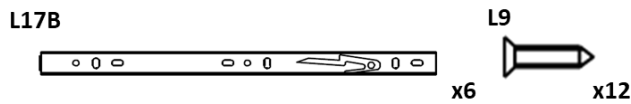
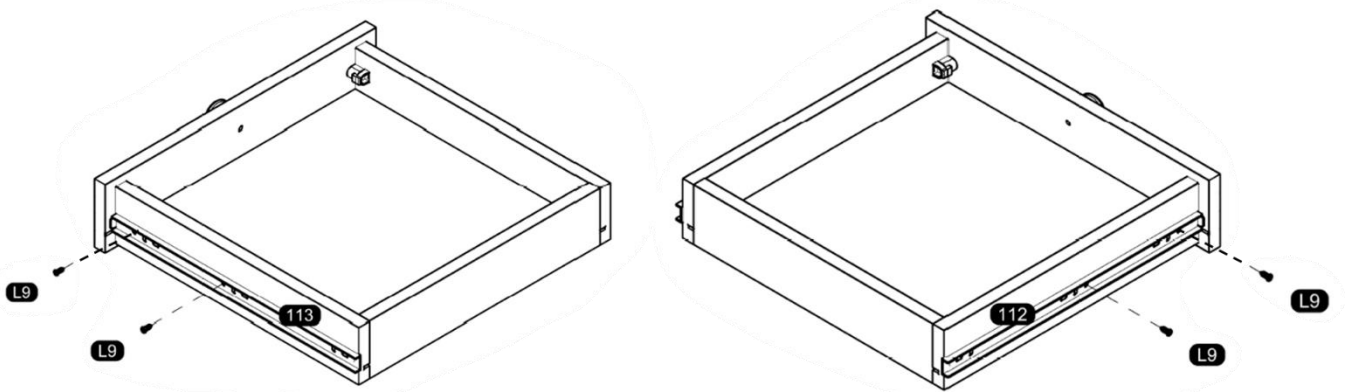

27

Place drawer organizer
Colocar el organizador de gaveta.

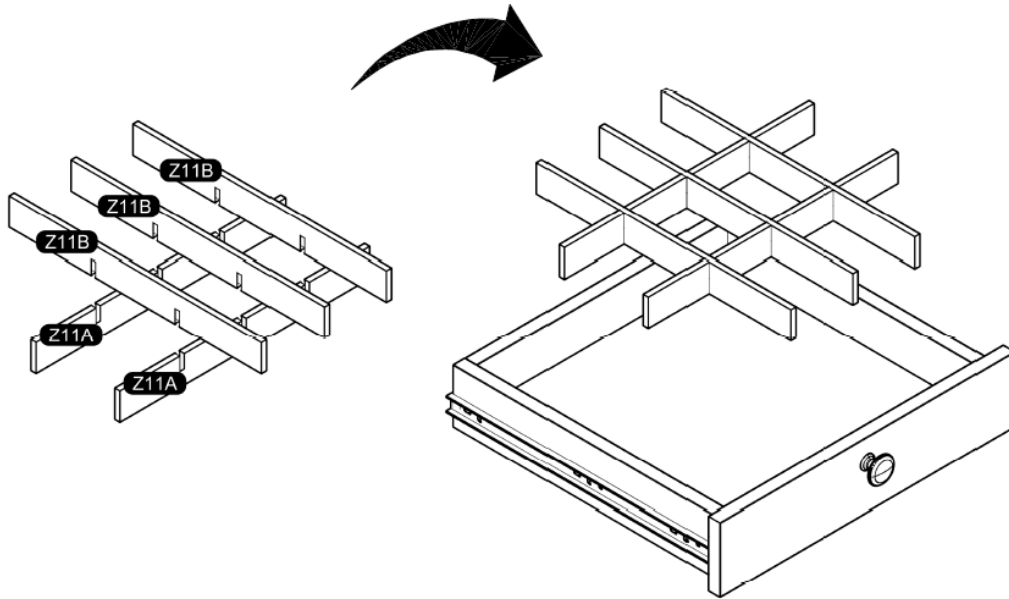

28

Fix furniture to the wall.
Fijar mueble a la pared.

TO AVOID ANY INJURY THE FURNITURE MUST BE FIXED ON THE WALL. THANKS.

PARA EVITAR CUALQUIER ACCIDENTE ES OBLIGATORIO ANCLAR EL MUEBLE EN LA PARED. GRACIAS.

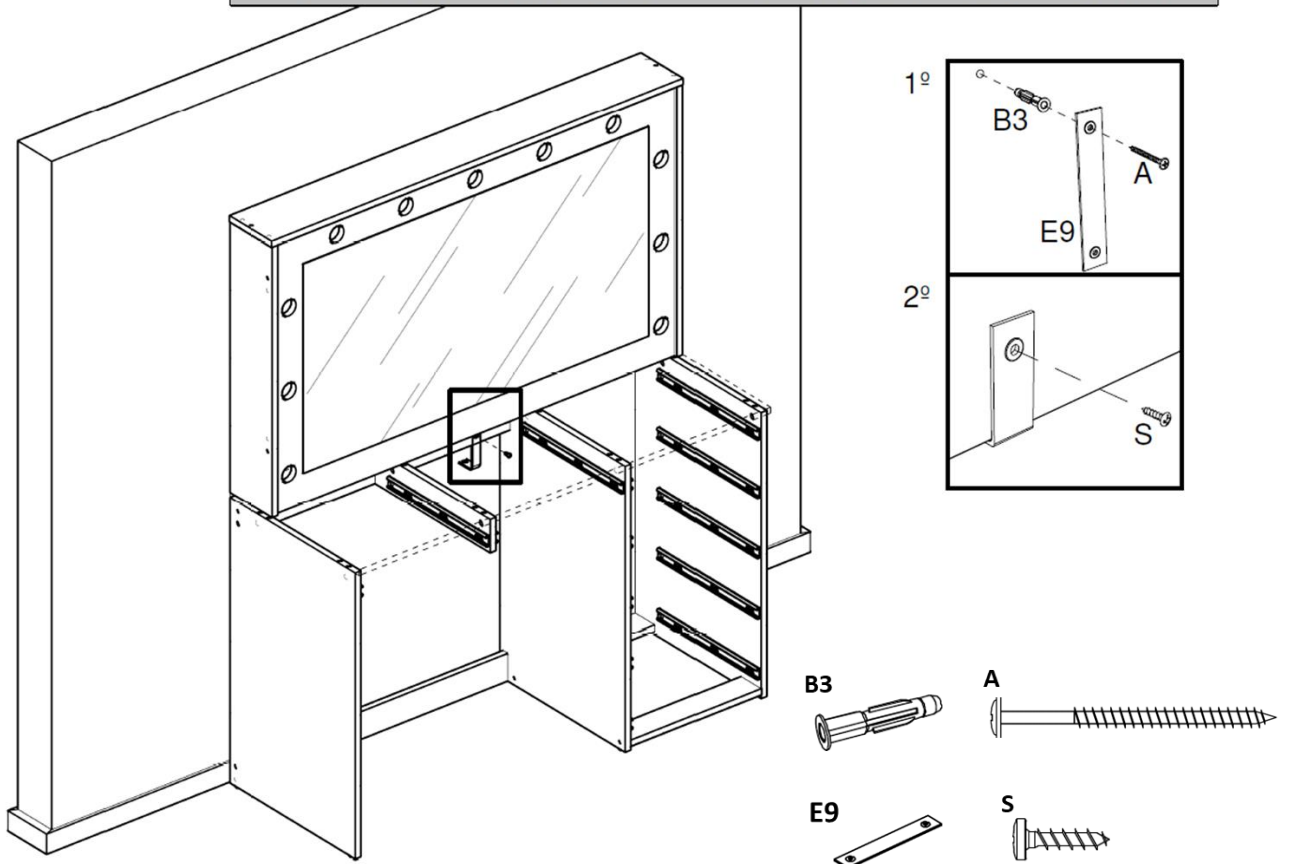

29

Finally place the glass top and drawers.
Finalmente coloque el tipo de vidrio y las gavetas.

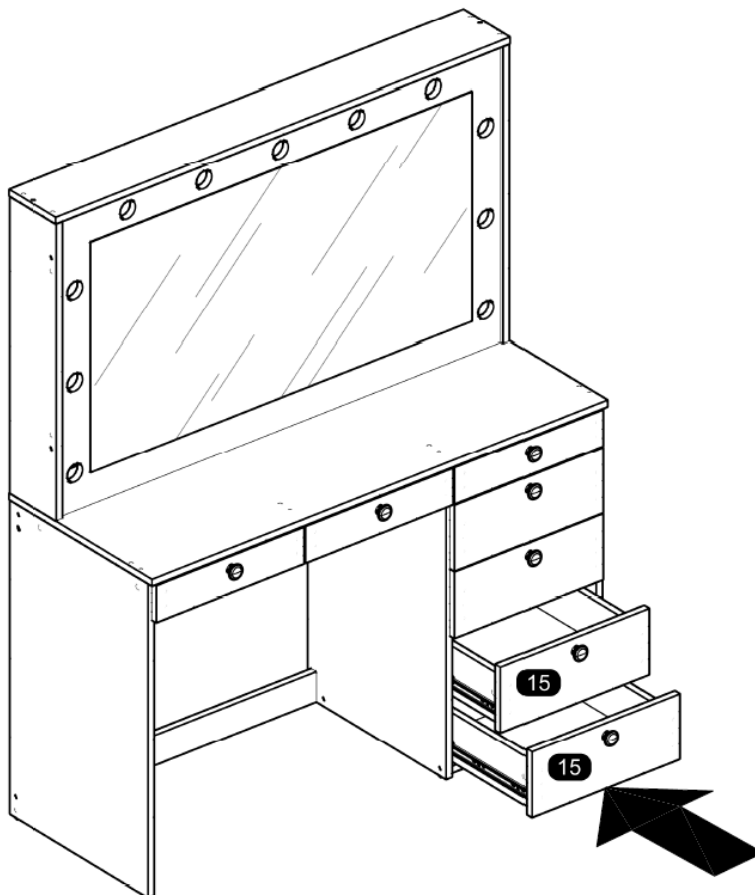

***Congratulations, you have assembled your DRESSING TABLE WITH MIRROR!!!
¡¡¡Felicitaciones, has armado tu Tocador con Espejo!!!***

1609-L Boahaus DRESSING TABLE WITH MIRROR Warranty

6-Months Limited Warranty

- a. Boahaus, LLC provides limited warranty coverage to the original purchaser of this product for a period of six months from the date of purchase against defects in materials or workmanship of Boahaus furniture components. As used in this Warranty, “defect” means imperfections in components which substantially impair the utility of the product. This Warranty gives you specific legal rights, and you may also have other rights which vary from state to state.
- b. There is no warranty coverage for defects or conditions that result from the failure to follow product assembly instructions, information or warnings, misuse or abuse, intentional damage, fire, flood, alteration or modification of the product, or use of the product in a manner inconsistent with its intended use, nor any condition resulting from incorrect or inadequate maintenance, cleaning, or care. There is also no warranty coverage for rented products or any products purchased “used” or “as is”, at a distress or going-out of business sale, or from a liquidator.
- c. As the exclusive remedy under this Warranty, Boahaus will (at its sole option) repair, replace or refund the value of any defective furniture component. Boahaus may require independent confirmation of the claimed defect and proof of purchase. Replacement parts will be warranted for only the remaining period of the original Warranty. BOAHAUS SHALL HAVE NO LIABILITY for ANY INCIDENTAL OR CONSEQUENTIAL DAMAGES OF ANY KIND and all such damages are EXCLUDED FROM THIS WARRANTY, such as loss of use, disassembly, transportation, labor or damage to property on or near the product. Some states do not allow the exclusion or limitation of incidental or consequential damages, so the above limitation or exclusion may not apply to you.
- d. This Warranty applies only to warranted defects that first arise and are transferred to subsequent owners or users of the product, and it shall be immediately void in the event the product is resold, transferred, leased or rented to any third party or person other than the original purchaser.
- e. THERE ARE NO OTHER WARRANTIES APPLICABLE TO THIS PRODUCT. Under the laws of certain states, there may be no implied warranties from Boahaus and all implied warranties, INCLUDING ANY IMPLIED WARRANTY OF MERCHANTABILITY OR FITNESS FOR A PARTICULAR PURPOSE are disclaimed where allowed by law. TO THE EXTENT ANY IMPLIED WARRANTIES ARE APPLICABLE, ANY IMPLIED WARRANTIES, INCLUDING ANY IMPLIED WARRANTY OF MERCHANTABILITY OR FITNESS FOR A PARTICULAR PURPOSE, ARE LIMITED IN DURATION TO THE DURATION OF THIS EXPRESS WARRANTY or the minimum period allowed by law, whichever is shorter. Some states do not allow limitations on how long an implied Warranty lasts, so the above limitation may not apply to you.
- f. For Warranty inquiries, questions about disposition or claims, please visit our website www.boahaus.com. You can also contact Boahaus at **+1 281-809-4043** or email at contact@boahaus.com Boahaus may require Warranty claims to be submitted in writing to:

Boahaus LLC.
1250-1252
Ave. Franklin Delano Roosevelt,
San Juan, PR 00926.

Please include your sales receipt or other proof of purchase and a specific description of the product defect.

Garantía de Tocador con Espejo 1609-L Boahaus

Garantía limitada de 6 meses

1. Boahaus, LLC proporciona cobertura de garantía limitada al comprador original de este producto por un período de 6 meses a partir de la fecha de compra contra defectos en materiales o mano de obra de componentes de muebles de Boahaus. Como se especifica en esta Garantía, "defecto" significa imperfecciones en componentes que perjudican sustancialmente la utilidad del producto. Esta Garantía le otorga derechos legales específicos y también puede tener otros derechos que varían de un estado a otro.
2. No hay cobertura de garantía por defectos o condiciones que resulten del incumplimiento de las instrucciones del producto, o advertencias, uso indebido o abuso, daño intencional, incendio, inundación, alteración o modificación del producto o uso del producto de manera inconsistente con su uso previsto, o cualquier condición resultante de mantenimiento incorrecto o inadecuado, limpieza o cuidado. Tampoco hay cobertura de garantía para productos alquilados o cualquier producto comprado "usado" o "tal cual", en una venta de emergencia o de salida de la empresa, o de un liquidador.
3. Boahaus puede requerir una confirmación independiente del defecto reclamado y un comprobante de compra. Las piezas de repuesto estarán garantizadas durante el período restante de la garantía original. BOAHAUS NO TENDRÁ NINGUNA RESPONSABILIDAD POR CUALQUIER DAÑO INCIDENTAL y todos estos daños ESTÁN EXCLUIDOS DE ESTA GARANTÍA, tales como pérdida de uso, desmontaje, transporte, mano de obra o daños a la propiedad en o cerca del producto. Algunos estados no permiten la exclusión o limitación de daños incidentales o consecuentes, por lo que la limitación o exclusión anterior puede no aplicarse a usted.
4. Esta Garantía se aplica únicamente a los defectos garantizados que surgen y se informan a Boahaus dentro del período de cobertura de la garantía. La garantía no puede ser transferida a los propietarios o usuarios posteriores del producto, y será inmediatamente nula en caso de que el producto sea revendido, transferido, arrendado o alquilado a cualquier tercero o persona que no sea el comprador original.
5. NO HAY OTRAS GARANTÍAS APLICABLES A ESTE PRODUCTO. Bajo las leyes de ciertos estados, no puede haber garantías implícitas de Boahaus y todas las garantías implícitas, INCLUYENDO CUALQUIER GARANTÍA IMPLÍCITA DE COMERCIABILIDAD O ADECUACIÓN PARA UN PROPÓSITO EN PARTICULAR, están exoneradas cuando permitido por la ley. TODAS LAS GARANTÍAS IMPLÍCITAS SON APLICABLES, LAS GARANTÍAS IMPLÍCITAS, INCLUIDAS CUALQUIER GARANTÍA IMPLÍCITA DE COMERCIABILIDAD O ADECUACIÓN PARA UN PROPÓSITO PARTICULAR, ESTÁN LIMITADAS EN DURACIÓN A LA DURACIÓN DE ESTA GARANTÍA EXPRESA o el período mínimo permitido por la ley, cualquiera que sea más corto. Algunos estados no permiten limitaciones sobre la duración de una garantía implícita, por lo que es posible que la limitación anterior no se aplique a usted.
6. Para consultas sobre la garantía, preguntas sobre la disposición o reclamaciones, visite nuestro sitio web www.boahaus.com. También puede ponerse en contacto con Boahaus al **+1 281-809-4043** o por correo electrónico en contact@boahaus.com. Boahaus puede requerir que los reclamos de garantía sean presentados por escrito a:

Boahaus LLC.
1250-1252
Ave. Franklin Delano Roosevelt,
San Juan, PR 00926.

Incluya su recibo de compra u otra prueba de compra y una descripción específica del defecto del producto.