

# BoatHaus

## ASSEMBLY INSTRUCTIONS

### ATTENTION!!!

Any inquiry or replacement parts  
you need, contact us directly at:

[contact@boahaus.com](mailto:contact@boahaus.com)

Scan this QR Code to chat to Customer Support Team.



Or Call Us at +1 (787) 688-1254

# BoaHaus

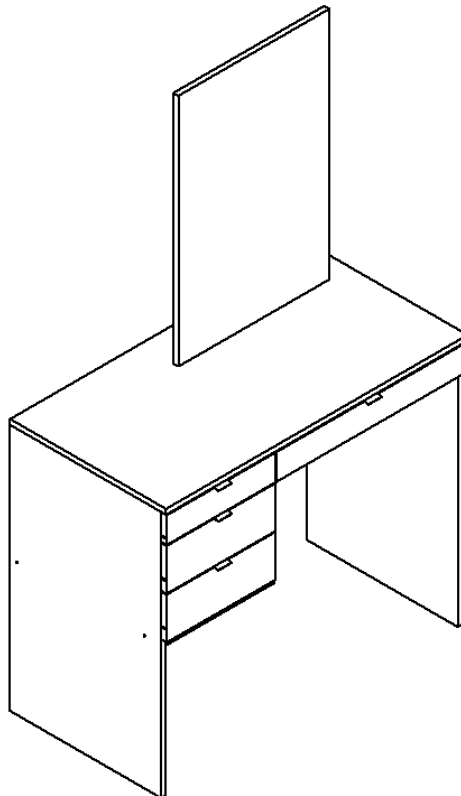
**ASSEMBLY INSTRUCTIONS****INSTRUCCIONES DE ARMADO****MODEL #: 1608****DRESSING TABLE WITH MIRROR****Tocador con espejo****Aprox. product weight 67 lbs. / 30.39 Kg.\***

\*Weight may vary +/- 5%.

**Lot: See package****Production date: See package****Purchase date: \_\_\_\_\_**

THIS INFORMATION BOOKLET CONTAINS IMPORTANT SAFETY INFORMATION. PLEASE READ AND KEEP FOR FUTURE REFERENCE.  
ESTE FOLLETO CONTIENE INFORMACIÓN DE SEGURIDAD IMPORTANTE. POR FAVOR, LEA Y GUÁRDELO PARA REFERENCIA FUTURA.

Need some Help? Call +1 (787) 688-1254 or email [contact@boahaus.com](mailto:contact@boahaus.com)  
¿Necesitas ayuda? Llama +1 (787) 688-1254 o envía un email [contact@boahaus.com](mailto:contact@boahaus.com)

Need some Help? Call +1 (787) 688-1254 or email [contact@boahaus.com](mailto:contact@boahaus.com)  
¿Necesitas ayuda? Llama +1 (787) 688-1254 o envía un email [contact@boahaus.com](mailto:contact@boahaus.com)

## GENERAL SAFETY INFORMATION

1. Please read the Assembly Instructions prior to assembling this product.
2. Remove all the hardware from the box and sort by type.
3. Check to see that all the hardware and parts are present BEFORE assembling.
4. To avoid damage, assemble the product on a sturdy, level and protective surface.
5. Please wait until all steps are completed before fully tightening bolts.
6. Make sure all bolts are tightly fastened before the unit is used.
7. To move the product, you must lift it. DO NOT drag it, if you drag it can cause overturning.
8. **This product is sold with a hardware kit to be fixed on the wall. You must install this kit to prevent any accidents or damages. When properly installed, this restrain can provide protection against the unexpected tipping of the unit due to small tremors, bumps or climbing. The restrain is only a deterrent and is not a substitute for proper adult supervision. Use of tip-over restraints may only reduce, but not eliminate, the risk of tip-over**

## INFORMACIÓN GENERAL DE SEGURIDAD

1. Lea las instrucciones de armado antes de ensamblar este producto.
2. Extraiga todo el hardware de la caja y ordene por tipo.
3. Verifique que todo el hardware y las piezas están presentes ANTES de ensamblar.
4. Para evitar daños, ensamble el producto sobre una superficie resistente, nivelada y con protección.
5. Espere hasta que todos los pasos se hayan completado antes de apretar completamente los tornillos y accesorios.
6. Asegúrese de que todos los tornillos y accesorios estén bien apretados antes de usar la unidad.
7. Para mover el producto debe levantarlo. NO lo arrastre, si lo arrastra puede causar volcamiento.
8. **Este producto se vende con un kit de accesorios para ser fijado en la pared. Debe instalar este kit para evitar accidentes o daños. Cuando se instala correctamente, esta restricción puede proporcionar protección contra la inclinación inesperada de la unidad debido a temblores pequeños, golpes o al treparse. La restricción es solo un elemento disuasivo y no es un sustituto de la supervisión adecuada de un adulto. El uso de restricciones de vuelco solo puede reducir, pero no eliminar, el riesgo de volcarse.**



## General Dimensions / Dimensiones Generales

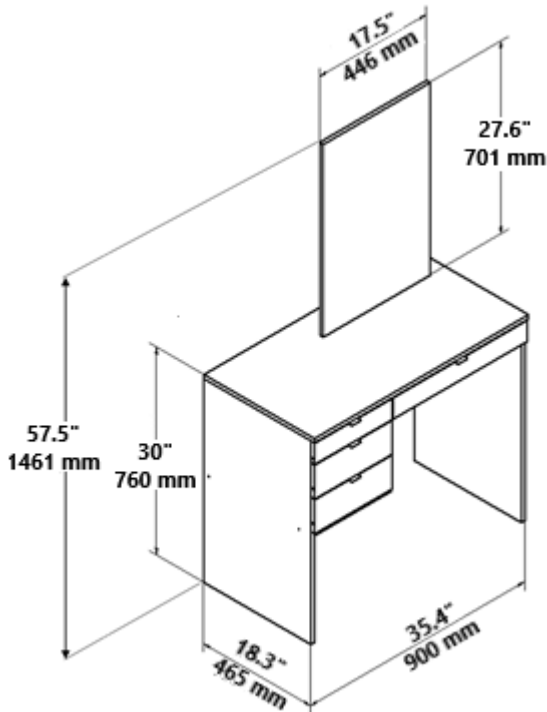

## Maximum weight supported / Peso máximo soportado

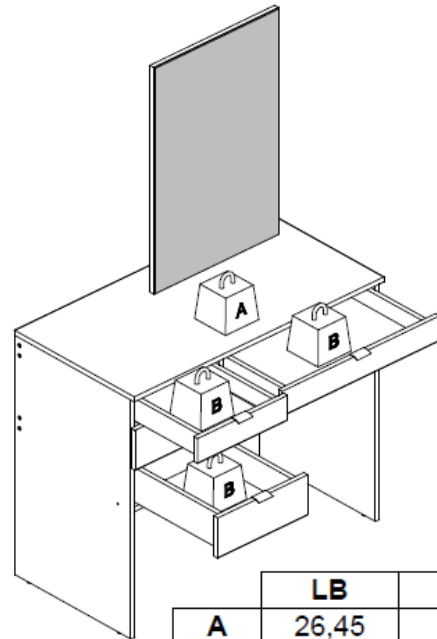

	LB	KG
A	26,45	12
B	6,6	3

### Weight in pounds. / Peso en libras.

Note: weight must be evenly distributed.

Nota: el peso debe estar distribuido uniformemente.

## You will need / usted necesitará:

Tools not included / herramientas no incluidas

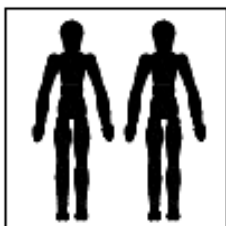

2 people  
2 personas

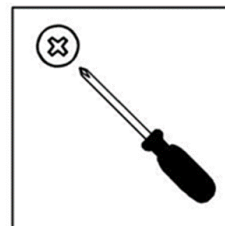

Screwdriver Phillips  
Destornillador estría

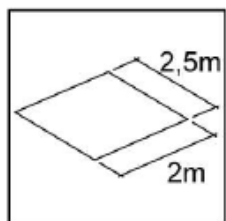

Recommended space for assemble  
Espacio recomendado para el armado



Hammer  
Martillo







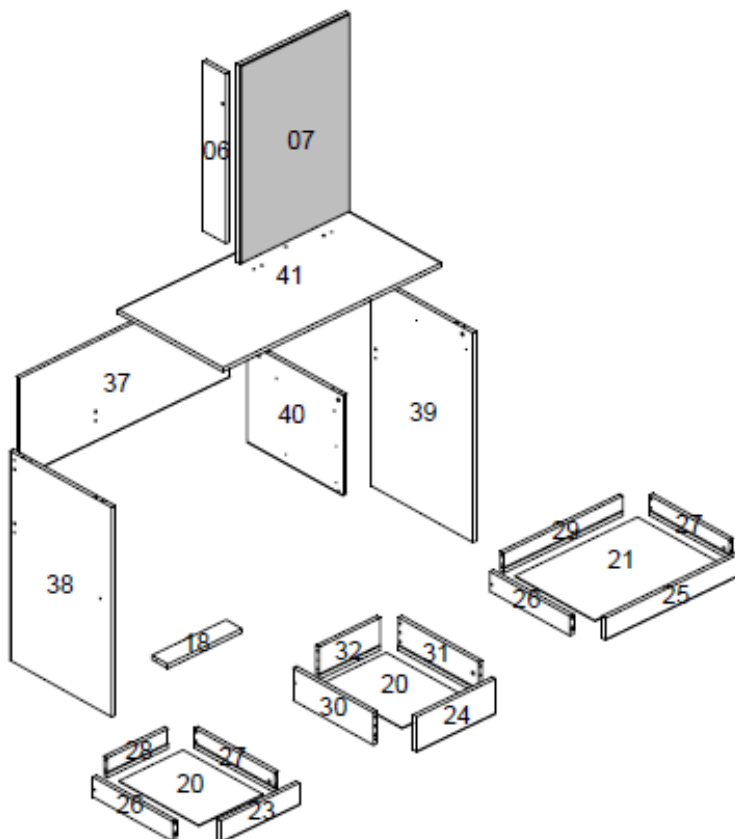



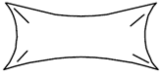



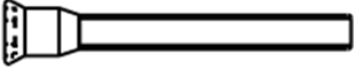

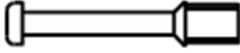

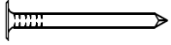
**Note: Place a carpet or blanket in the assembly area to avoid damage to the parts during the process.**  
**Nota: Colocar una alfombra o manta en el area de armado para evitar daños en las piezas durante el proceso.**

**PARTS IDENTIFICATION / IDENTIFICACION DE PARTES**

Number	Description	Qty.
6	Tray / Travesaño	1
7	Mirror / Espejo	1
18	Drawer plinth / Zócalo de cajón	1
20	Small bottom of drawer / Fondo pequeno de cajón	3
21	Large bottom of drawer / Fondo grande de cajón	1
23	Front of left top drawer / Frontal de cajón superior izquierdo	1
24	Front of bottom drawer / Frontal de cajón inferior	2
25	Front of right top drawer / Frontal de cajón superior derecho	1
26	Left side of top drawer / Lateral izquierdo de cajón superior	2
27	Right side of top drawer / Lateral derecho de cajón superior	2
28	Rear of left top drawer / Posterior de cajón superior izquierdo	1
29	Rear of right top drawer / Posterior de cajón superior derecho	1
30	Left side of bottom drawer / Lateral izquierdo de cajón inferior	2
31	Right side of bottom drawer / Lateral derecho de cajón inferior	2
32	Rear of bottom drawer / Posterior de cajón inferior	2
37	Back panel / Panel trasero	1
38	Left side / Lateral izquierdo	1
39	Right side / Lateral derecho	1
40	Division / División	1
41	Top base / Base superior	1



**IDENTIFICATION OF ACCESSORIES / IDENTIFICACION DE ACCESORIOS**

NUMBER		DESCRIPTION	QTY
A1		Glue / Pegamento	1
A2		Small plastic foot / Pie plástico	4
A3		Trapeze / Trapecio	2
E		Wooden dowel / Pin	38
G		Structural screw / Tornillo estructural (5 x 50 mm)	7
H		Allen key / Llave allen	1
I		Structural screw cover / Tapa de tornillo estructural	7
J		Simple minifix screw / Tornillo minifix simple	14
L		Drum lock / Tambor minifix	14
M		Adhesive bore patch / Tapones adhesivos	8
N		Nail / Clavo	4
O		Flat head screw / Tornillo cabeza plana (4,5 x 45 mm)	11
P		Flanged head screw / Tornillo cabeza flangeada (4,5 x 25 mm)	2
P5		Flat head screw / Tornillo cabeza plana (3,5 x 14 mm)	36
R		Flat head screw / Tornillo cabeza plana 6 x 8 mm	4
S2		Handle / Manilla	4
VA		Metallic left slide / Corredera lateral izquierda	4
VB		Metallic right slide / Corredera lateral derecha	4
VC		Left drawer slide / Corredera de cajón izquierda	4
VD		Right drawer slide / Corredera de cajón derecha	4
Z		Plastic hole plugs / Tapones plásticos	4

**PRE-ASSEMBLY / PRE- ARMADO**

1. Fix **wooden dowel (E)** and **metallic left slide (VA)** to **left side (38)**.  
Fijar **pin (E)** y **corredera lateral izquierda (VA)** a **lateral izquierdo (38)**.

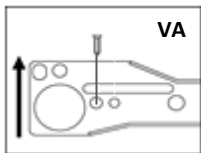
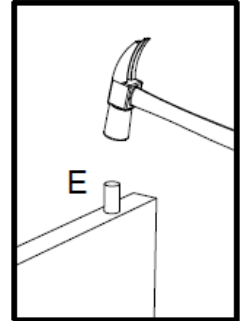
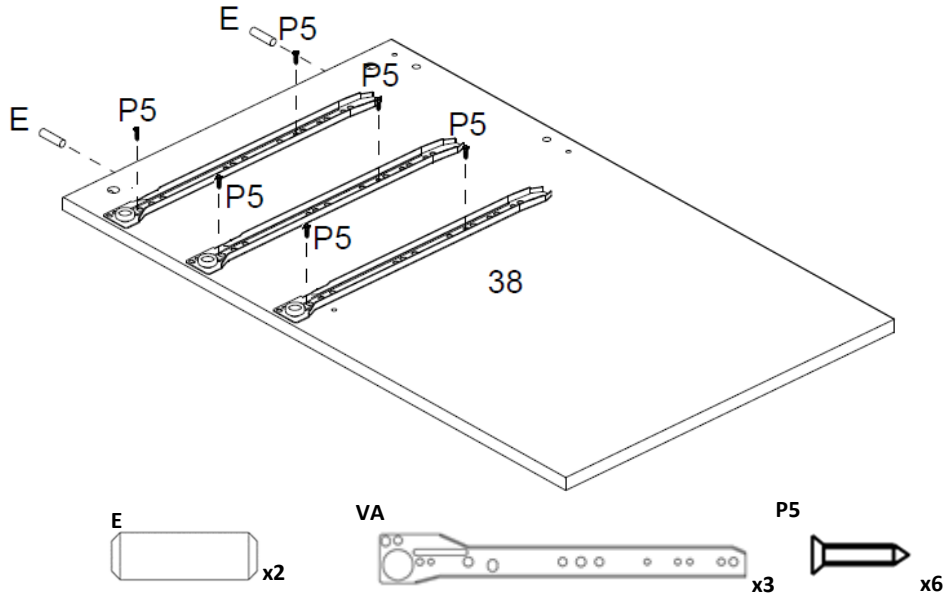

**Note: the two upper holes have to be facing up.**  
**Nota: los dos agujeros superiores deben estar hacia arriba.**

2. Fix **wooden dowel (E)** and **metallic right slide (VB)** to **right side (39)**.  
Fijar **pin (E)** y **corredera lateral derecha (VB)** a **lateral derecho (39)**.

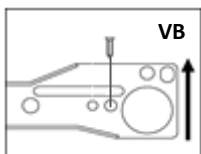
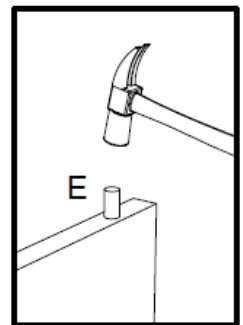
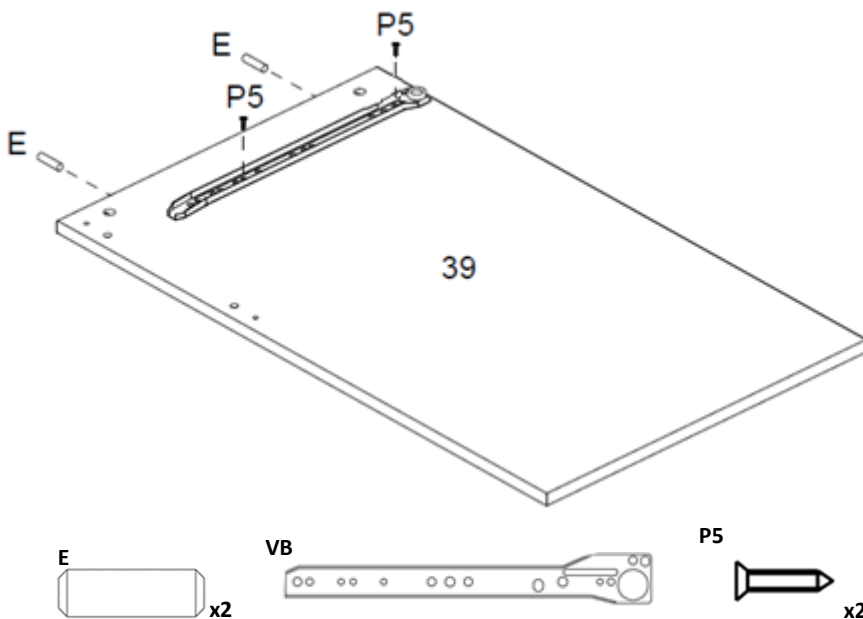

**Note: the two upper holes have to be facing up.**  
**Nota: los dos agujeros superiores deben estar hacia arriba.**

3. Fix **wooden dowel** (E), **metallic left slide** (VA) to **division** (40). Flip and fix **metallic right slide** (VB) to **division** (40).

Fijar **pin** (E), **corredera lateral izquierda** (VA) a **división** (40). Voltrear y fijar **corredera lateral derecha** (VB) a **división** (40).

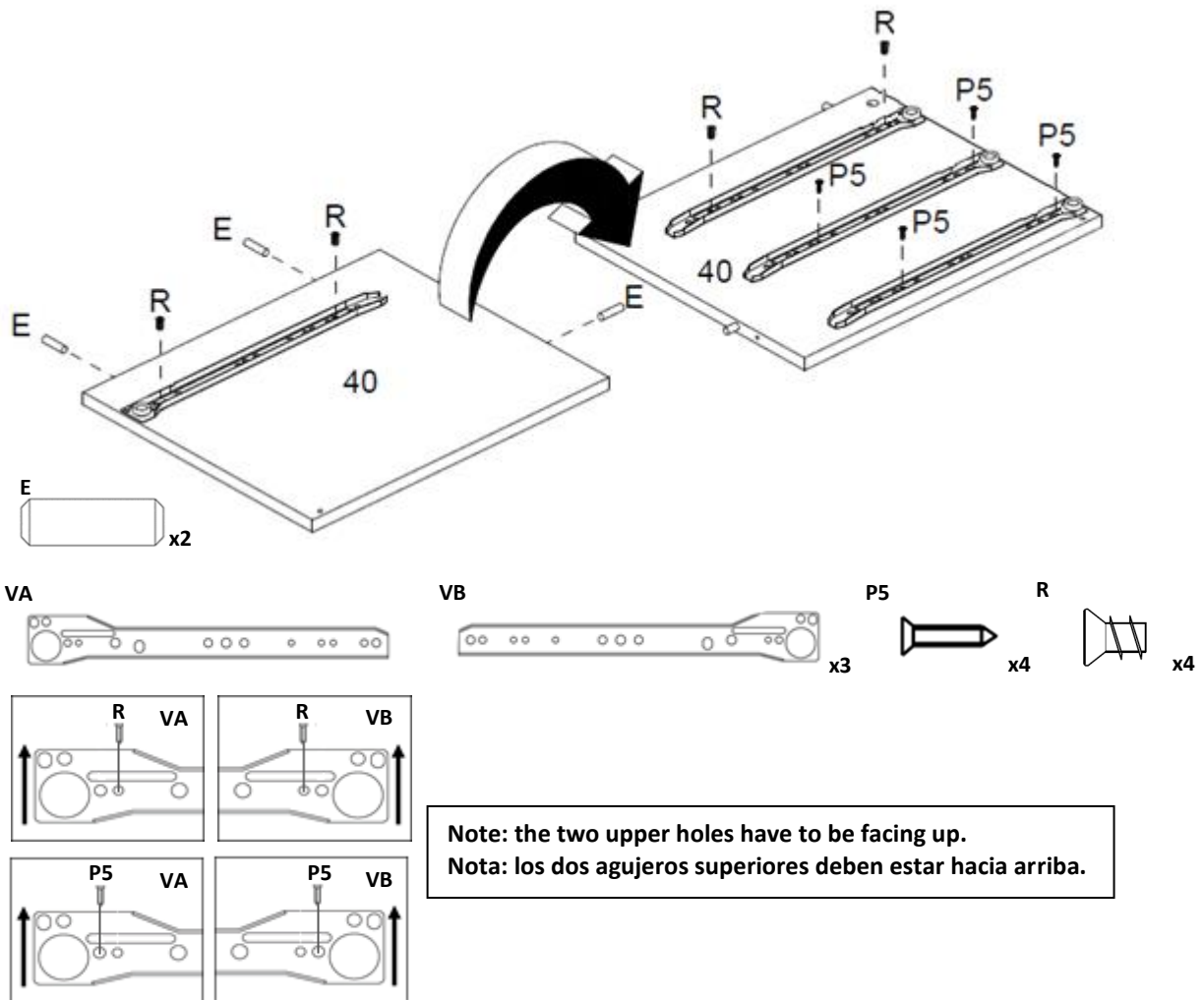

4. Fix **wooden dowel** (E) to **back panel** (37) and **mirror** (7).  
 Fijar **pin** (E) a **panel trasero** (37) y **espejo** (7).

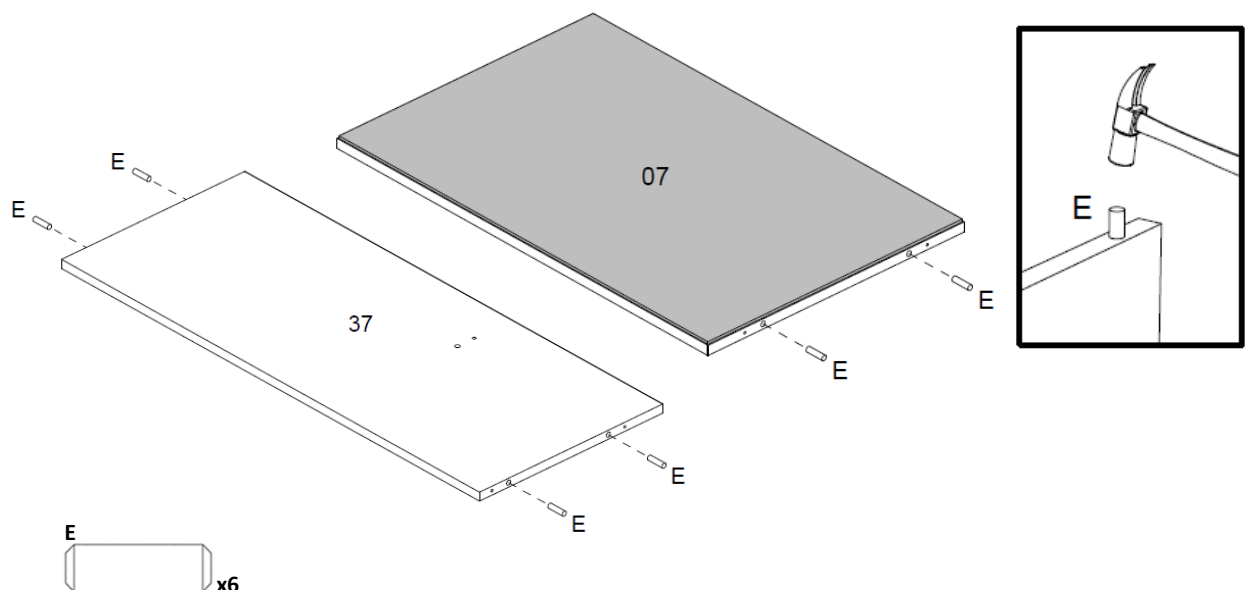





7. Fix **wooden dowel (E)** to **rear of left top drawer (28)**, **rear of right top drawer (29)**, **left side of top drawer (26) x2** and **right side of top drawer (27) x2**.  
 Fijar **pin (E)** a **posterior de cajón superior izquierdo (28)**, **posterior de cajón superior derecho (29)**, **lateral izquierdo de cajón superior (26) x2** y **lateral derecho de cajón superior (27) x2**.

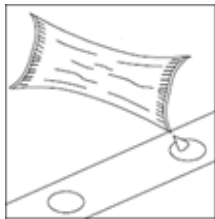
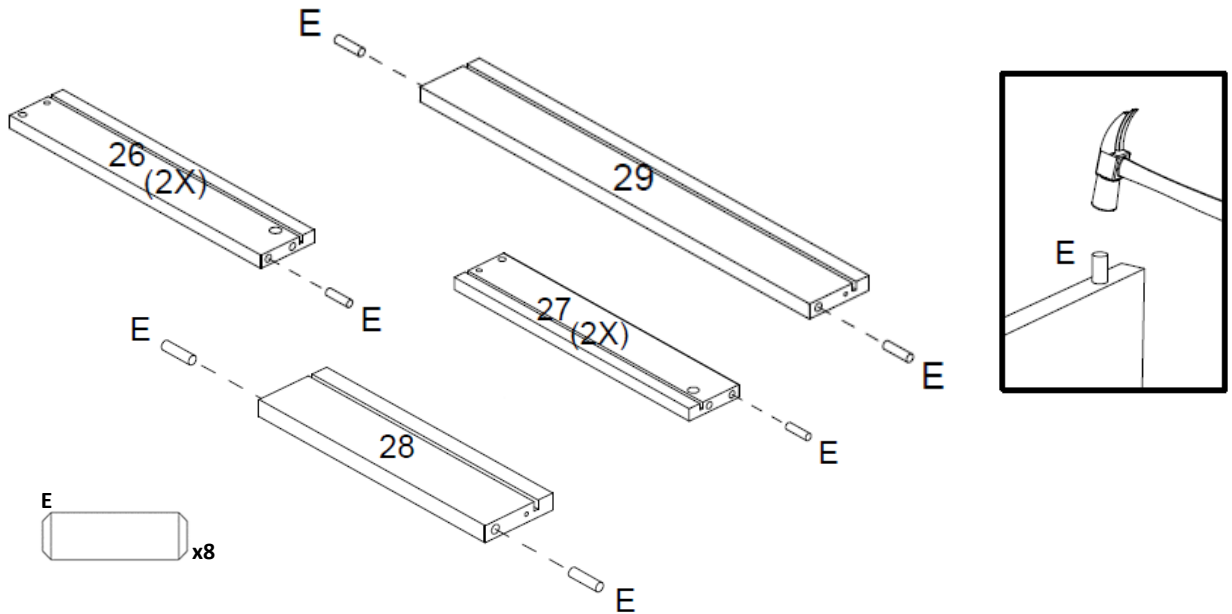

**Note: add glue (A1) in the holes before placing the wooden dowel**  
**Nota: agregue el pegamento (A1) en los agujeros antes de colocar el pin.**

8. Fix **wooden dowel (E)** to **rear of bottom drawer (32) x2**, **left side of bottom drawer (30) x2** and **right side of bottom drawer (31) x2**.  
 Fijar **pin (E)** a **posterior de cajón inferior (32) x2**, **lateral izquierdo de cajón inferior (30) x2** y **lateral derecho de cajón inferior (31) x2**.

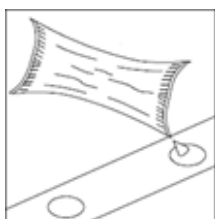
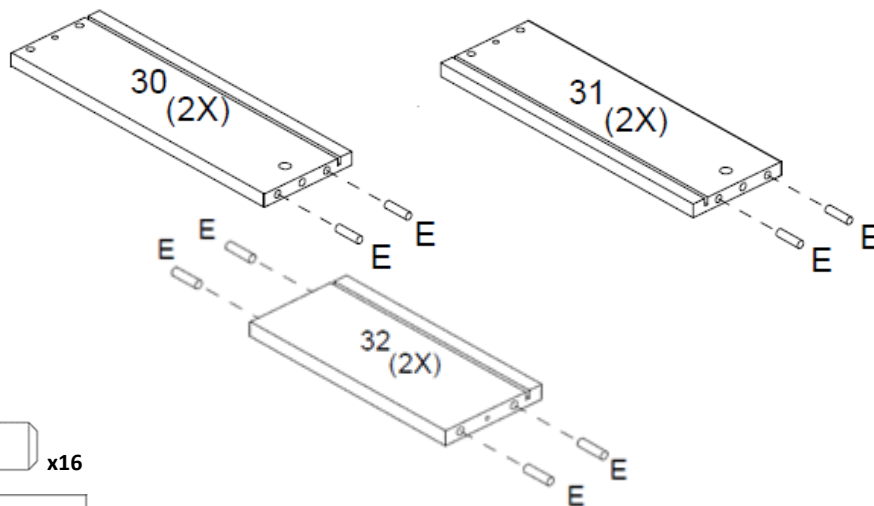

**Note: add glue (A1) in the holes before placing the wooden dowel**  
**Nota: agregue el pegamento (A1) en los agujeros antes de colocar el pin.**

9. Fix *simple minifix screw* (J) to *front of left top drawer* (23), *front of bottom drawer* (24) x2 and *front of right top drawer* (25).

Fijar *tornillo minifix simple* (J) a *frontal de cajón superior izquierdo* (23), *frontal de cajón inferior* (24) x2 y *frontal de cajón superior derecho* (25).

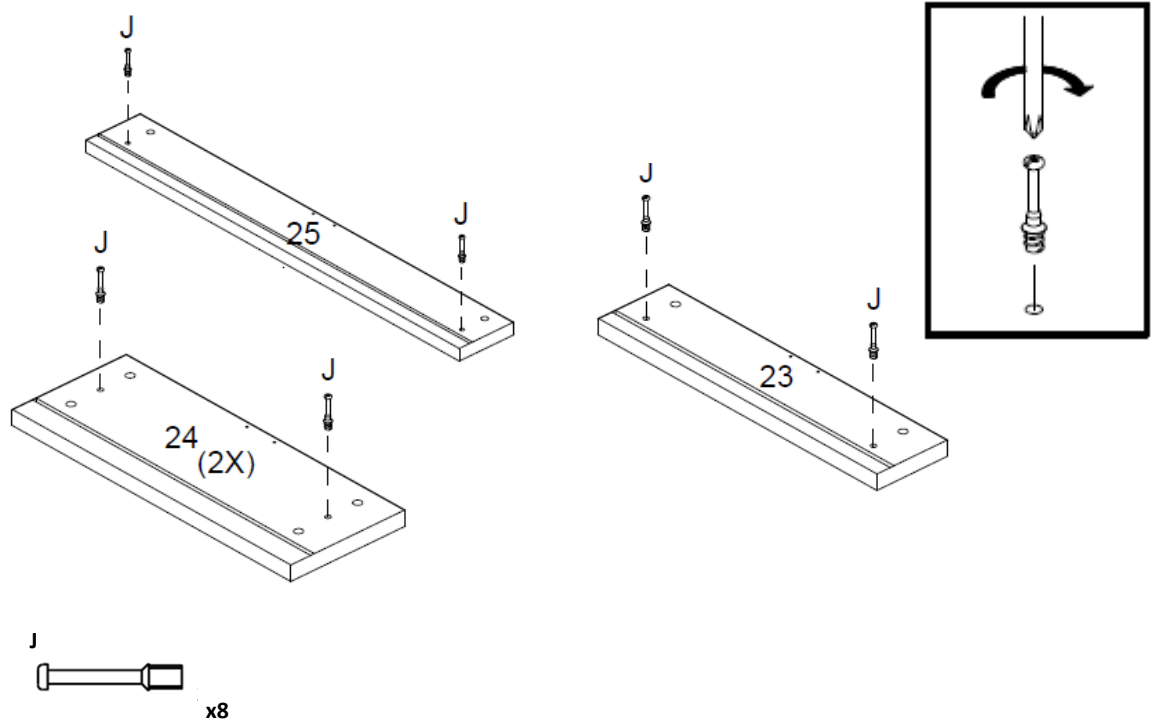

**ASSEMBLY / ARMADO**

10. Fix *division* (40) to *back panel* (37).  
 Fijar *división* (40) a *panel trasero* (37).

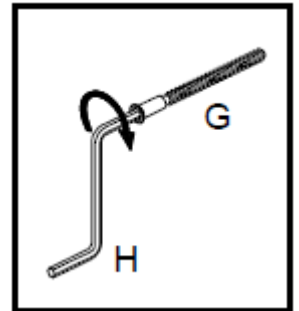
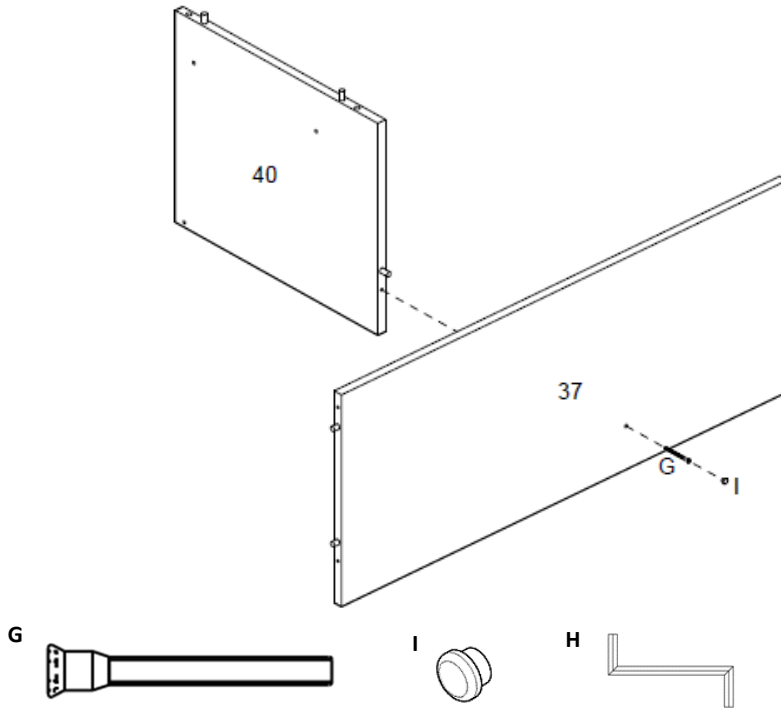

**Note: use the allen key (H) to adjust the structural screws (G).**  
**Nota: usar la llave allen (H) para ajustar los tornillos estructurales (G).**

11. Fix *drawer plinth* (18) to previous assembly.  
 Fijar *zócalo de cajón* (18) a ensamble previo.

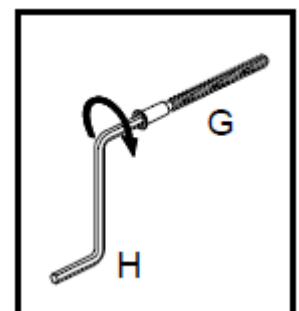
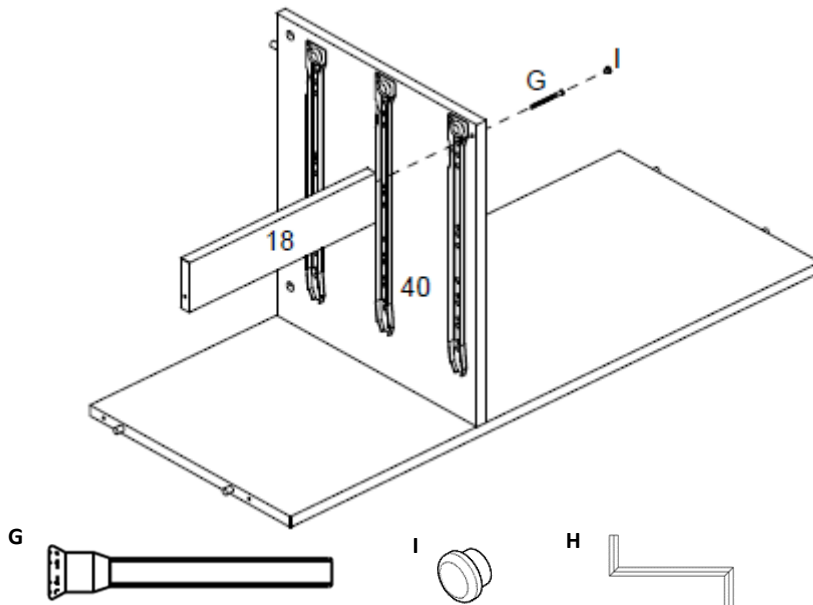

**Note: use the allen key (H) to adjust the structural screws (G).**  
**Nota: usar la llave allen (H) para ajustar los tornillos estructurales (G).**

12. Fix **left side** (38) to previous assembly.  
 Fijar **lateral izquierdo** (38) a ensamble previo.

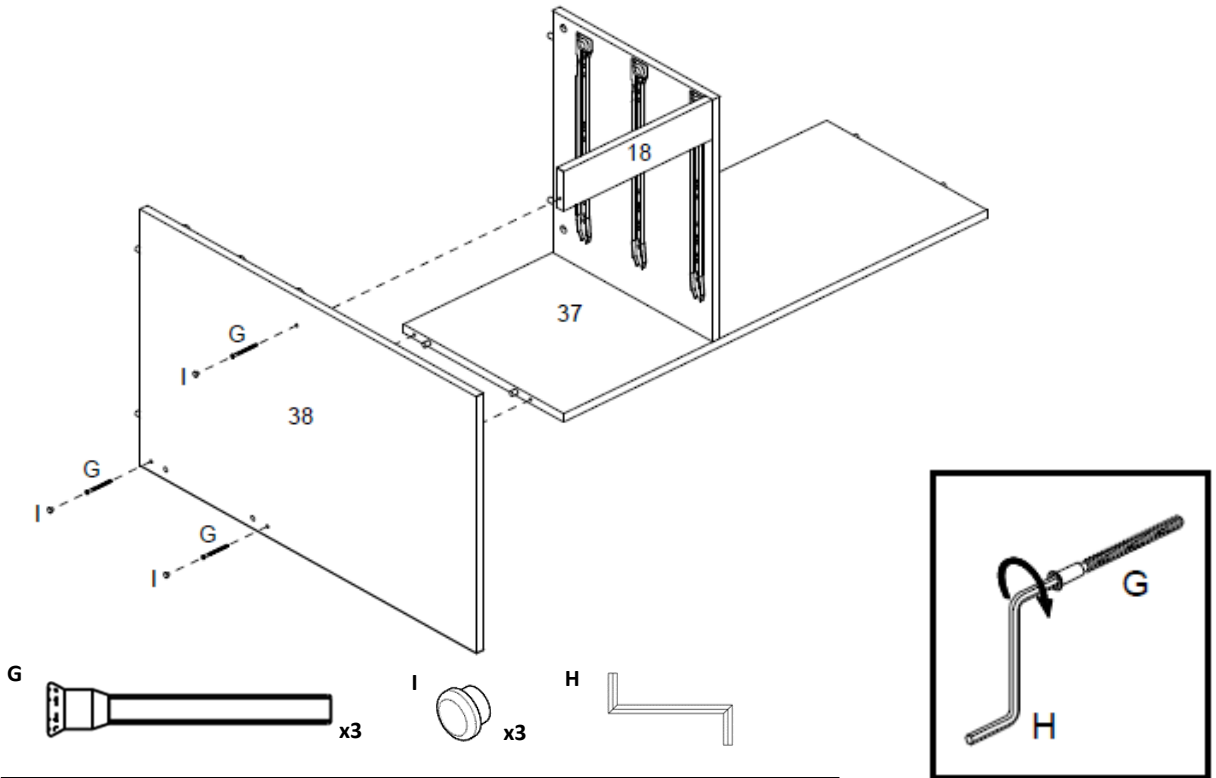

Note: use the allen key (H) to adjust the structural screws (G).  
 Nota: usar la llave allen (H) para ajustar los tornillos estructurales (G).

13. Fix **right side** (39) to previous assembly.  
 Fijar **lateral derecho** (39) a ensamble previo.

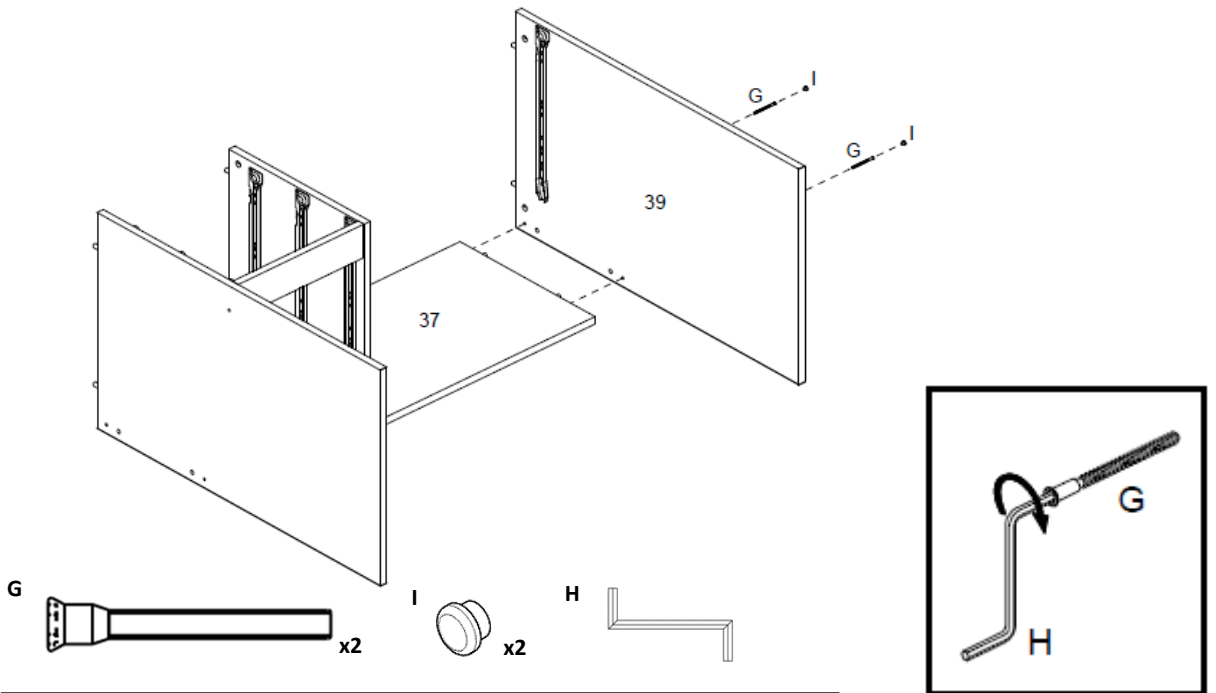

Note: use the allen key (H) to adjust the structural screws (G).  
 Nota: usar la llave allen (H) para ajustar los tornillos estructurales (G).

14. Fix *tray* (6) to *top base* (41).

Fijar *travesaño* (6) a *base superior* (41).

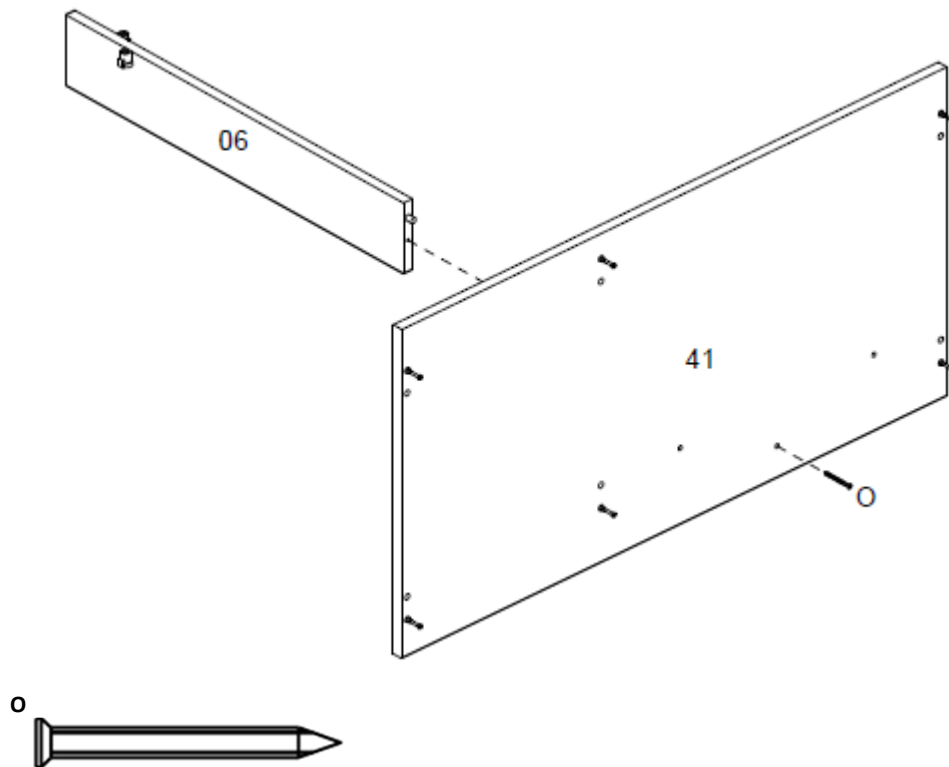

15. Fix *mirror* (7) to previous assembly.

Fijar *espejo* (7) a ensamble previo.

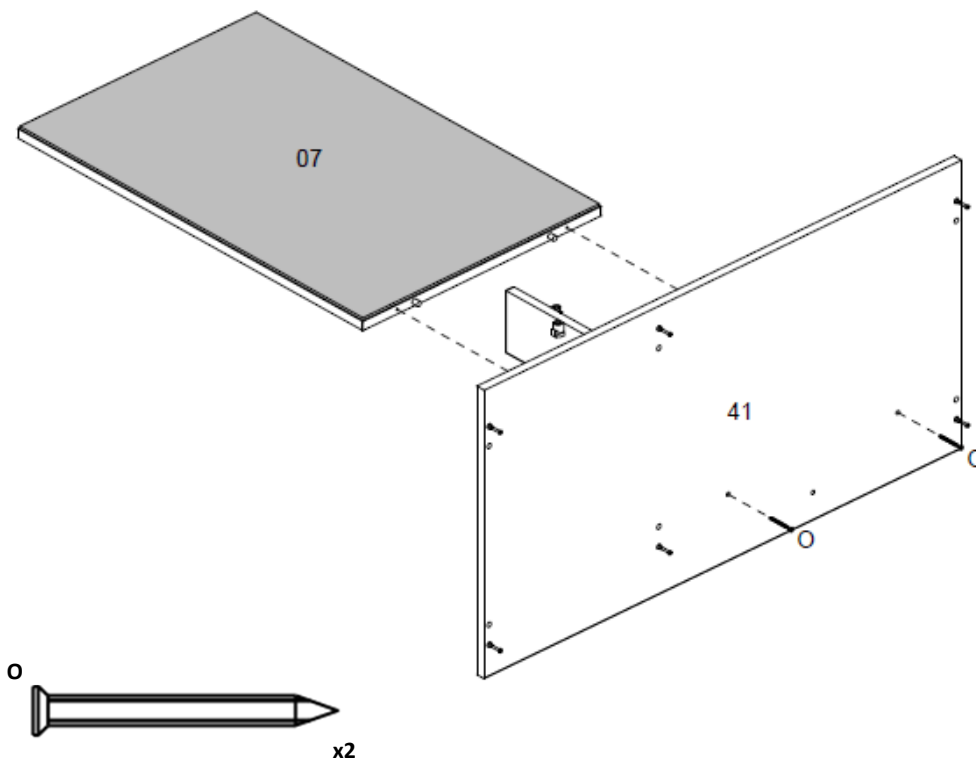

16. Fix both previous assemblies (13 and 15). And fix **small plastic foot** (A2).  
 Fijar ambos ensambles previos (13 y 15). Y fijar **pie plástico** (A2).

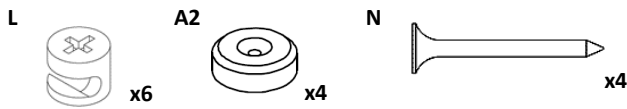
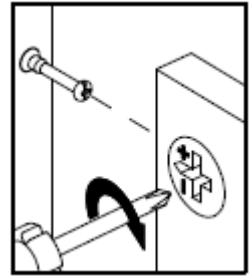
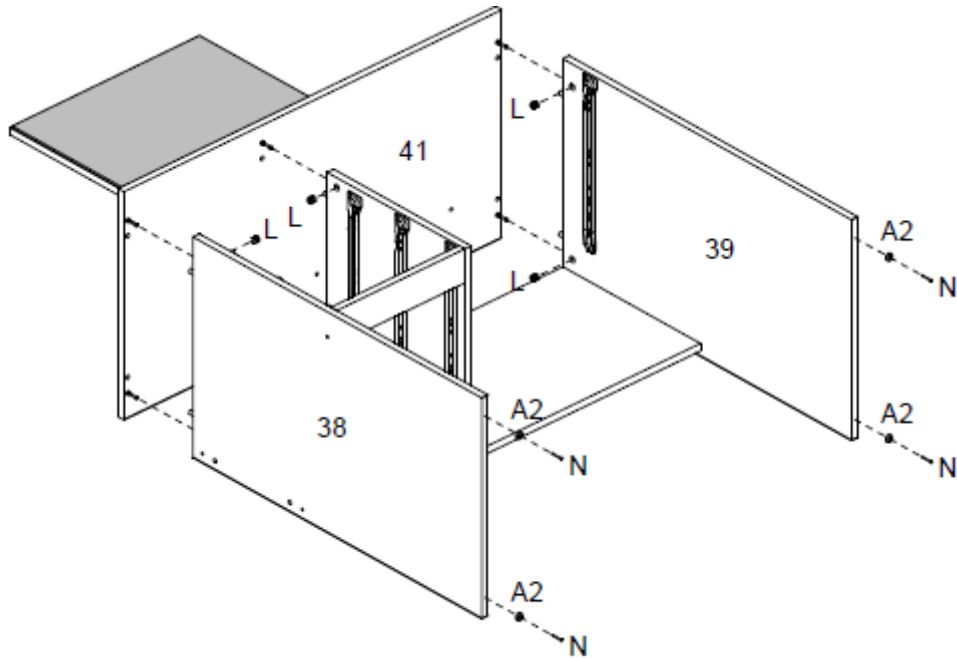

17. Fix **plastic hole plugs** (Z) and **trapeze** (A3) to furniture.  
 Fijar **tapones plásticos** (Z) y **trapecio** (A3) a mueble.

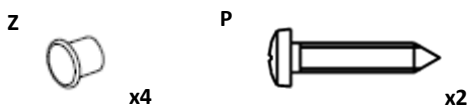
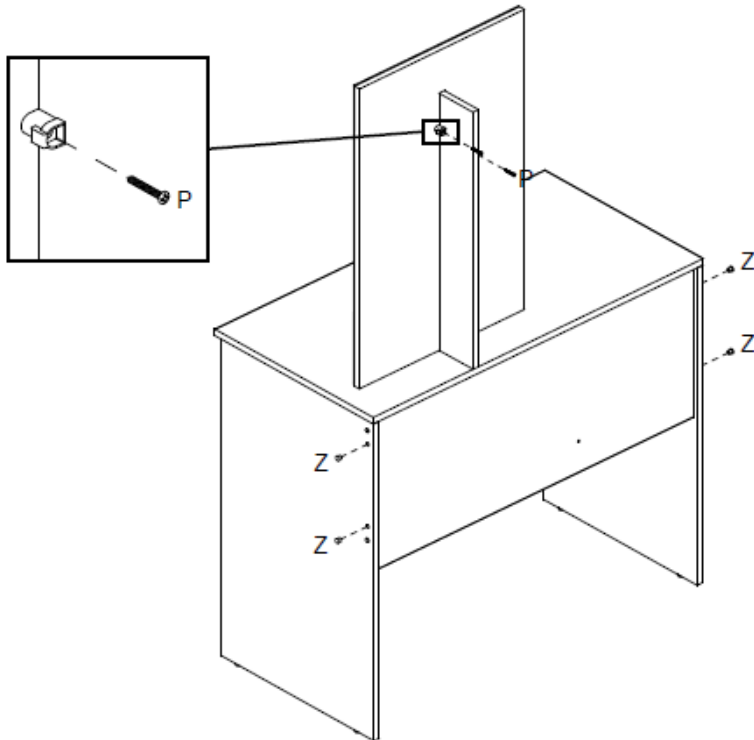

18. Fix **left side of bottom drawer** (30) x2, **right side of bottom drawer** (31) x2 and **small bottom of drawer** (20) x2 to **rear of bottom drawer** (32) x2.  
 Fijar **lateral izquierdo de cajón inferior** (30) x2, **lateral derecho de cajón inferior** (31) x2 y **fondo pequeño de cajón** (20) x2 a **posterior de cajón inferior** (32) x2.

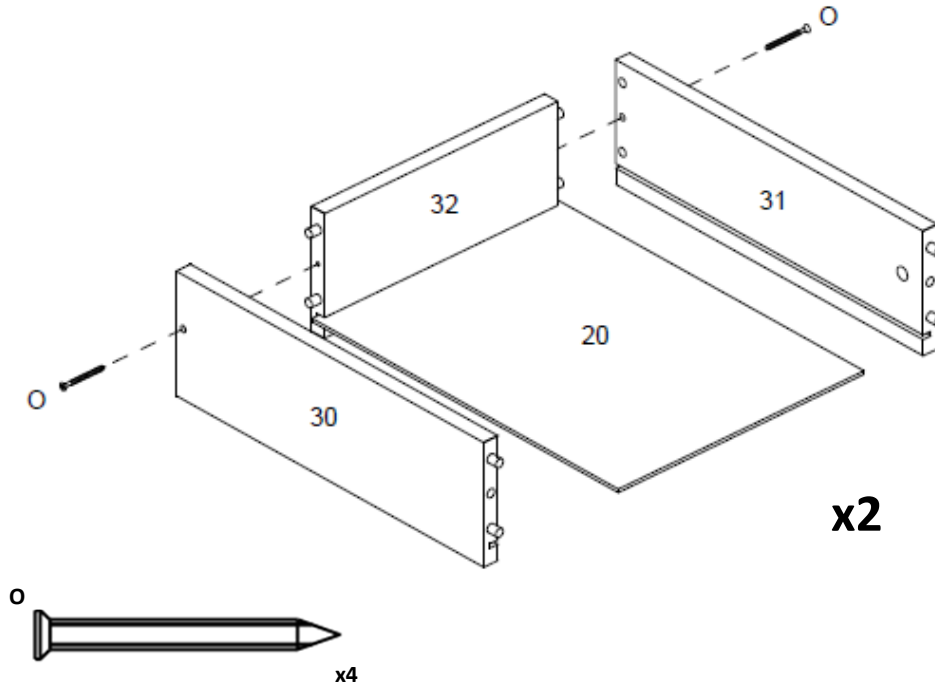

19. Fix **handle** (S2) x2 and **front of left bottom drawer** (24) x2 to previous assembly.  
 Fijar **tirador** (S2) x2 y **frente de cajón inferior izquierdo** (24) x2 a ensamble previo.

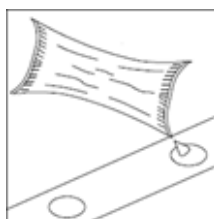
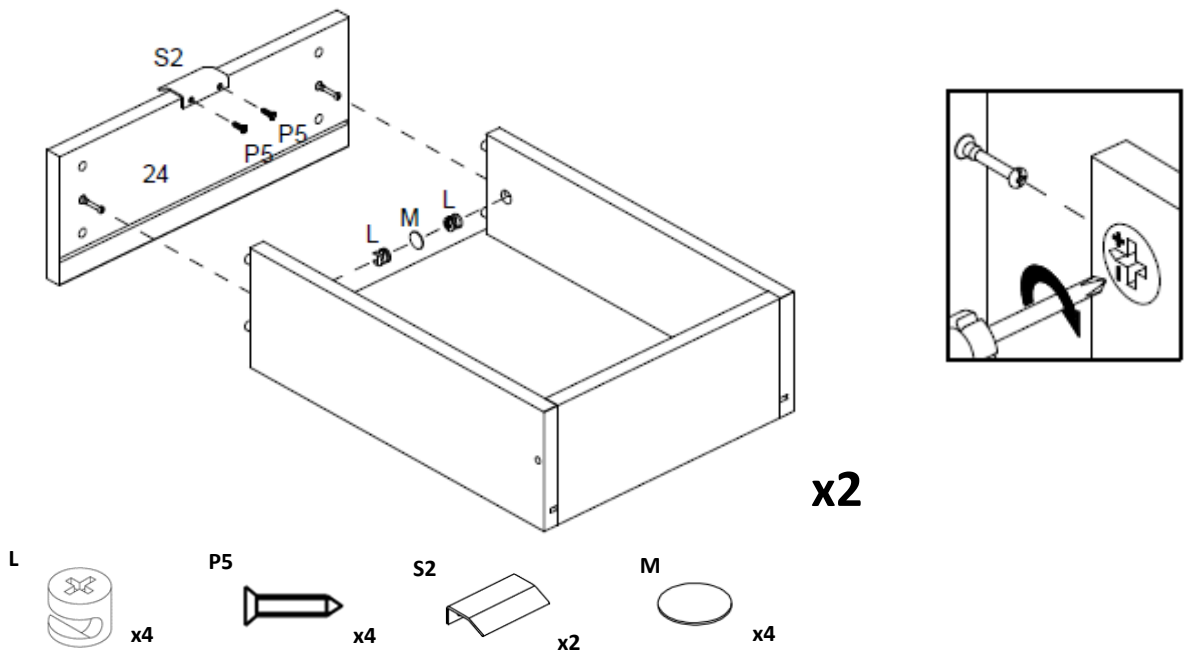

**Note: add glue (A1) in the holes before placing the wooden dowel**  
**Nota: agregue el pegamento (A1) en los agujeros antes de colocar el pin.**



20. Fix **left drawer slide** (VC) x2 and **right drawer slide** (VD) x2 to drawer.

Fijar **corredera de cajón izquierda** (VC) x2 y **corredera de cajón derecha** (VD) x2 a cajón.

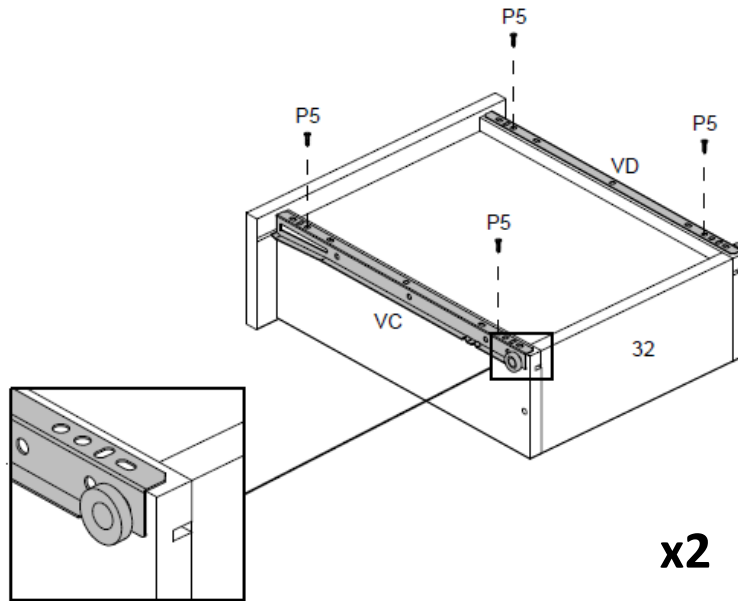

x2

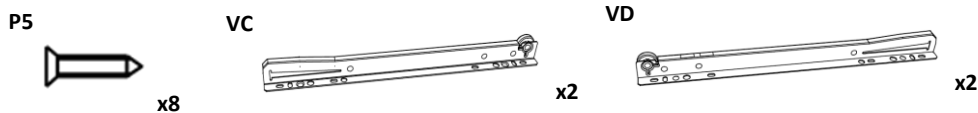

21. Fix **left side of top drawer** (26), **right side of top drawer** (27) and **small bottom of drawer** (20) to **rear of left top drawer** (28).

Fijar **lateral izquierdo de cajón superior** (26), **lateral derecho de cajón superior** (27) y **fondo pequeño de cajón** (20) a **posterior de cajón superior izquierdo** (28).

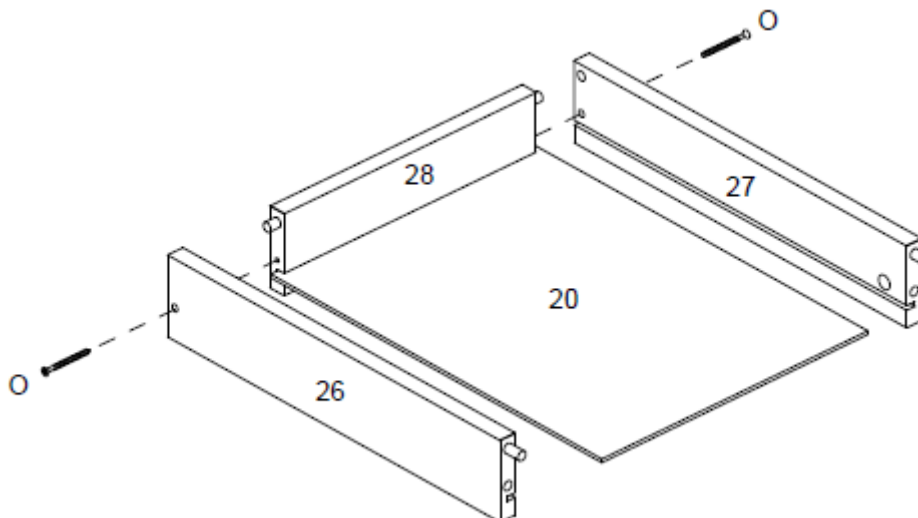

22. Fix **handle** (S2) and **front of left top drawer** (23) to previous assembly.  
 Fijar **tirador** (S2) y **frente de cajón superior izquierdo** (23) a ensamble previo.

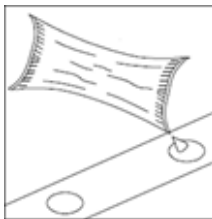
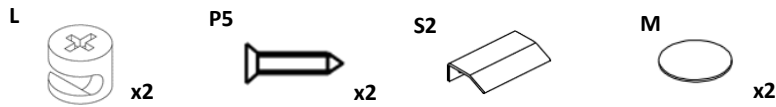
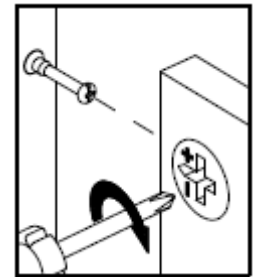
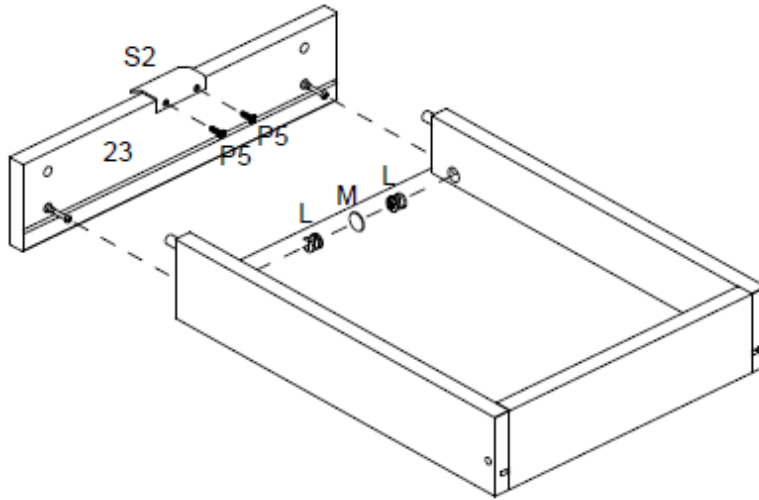

**Note: add glue (A1) in the holes before placing the wooden dowel**  
**Nota: agregue el pegamento (A1) en los agujeros antes de colocar el pin.**

23. Fix **left drawer slide** (VC) and **right drawer slide** (VD) to drawer.  
 Fijar **corredera de cajón izquierda** (VC) y **corredera de cajón derecha** (VD) a cajón.

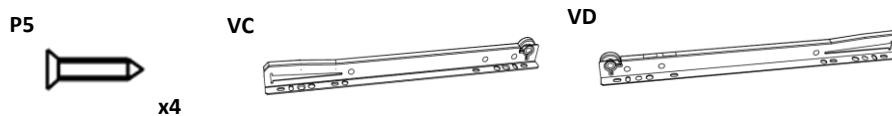
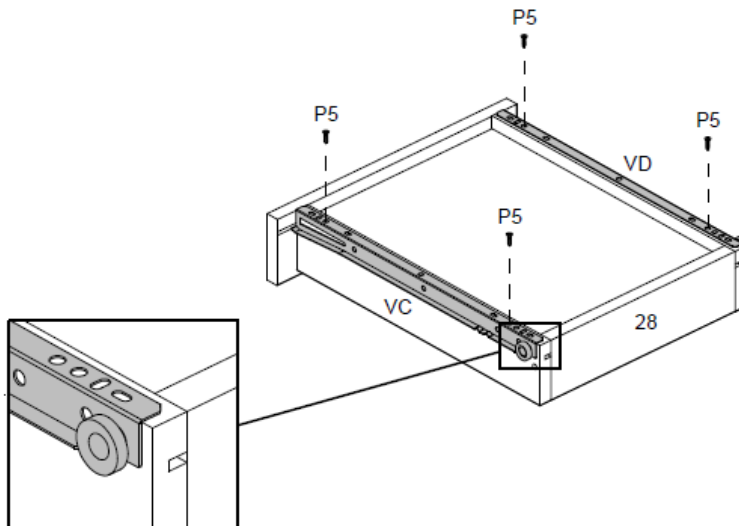

24. Fix **left side of top drawer** (26), **right side of top drawer** (27) and **large bottom of drawer** (21) to **rear of right top drawer** (29).

Fijar **lateral izquierdo de cajón superior** (26), **lateral derecho de cajón superior** (27) y **fondo grande de cajón** (21) a **posterior de cajón superior derecho** (29).

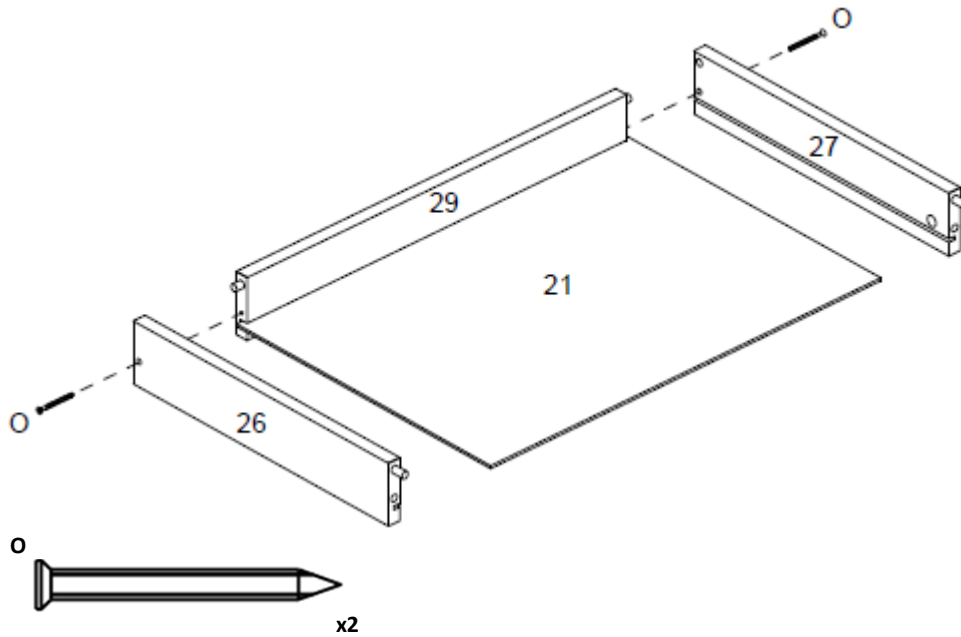

25. Fix **handle** (S2) and **front of right top drawer** (25) to previous assembly.

Fijar **tirador** (S2) y **frente de cajón superior derecho** (25) a ensamble previo.

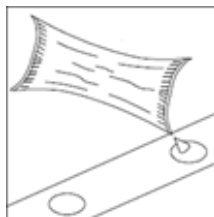
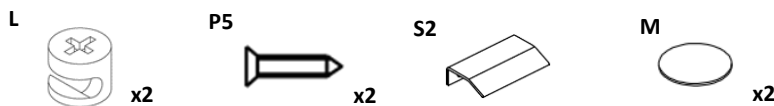
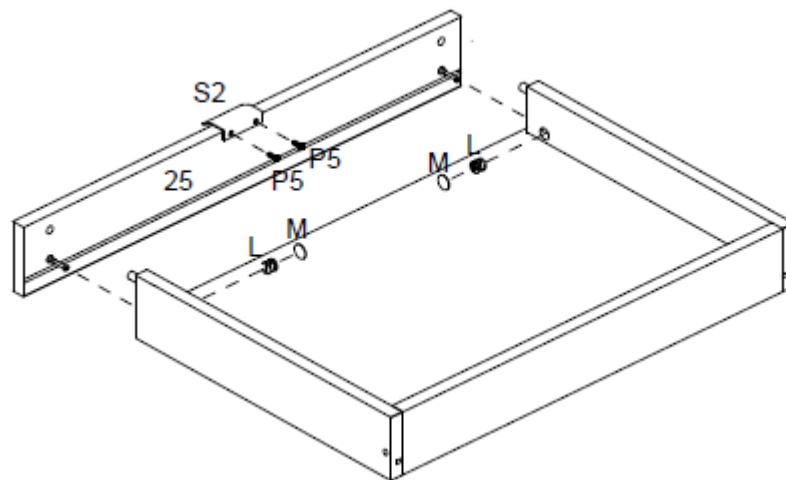

Note: add glue (A1) in the holes before placing the wooden dowel  
 Nota: agregue el pegamento (A1) en los agujeros antes de colocar el pin.

26. Fix **left drawer slide** (VC) and **right drawer slide** (VD) to drawer.

Fijar **corredera de cajón izquierda** (VC) y **corredera de cajón derecha** (VD) a cajón.

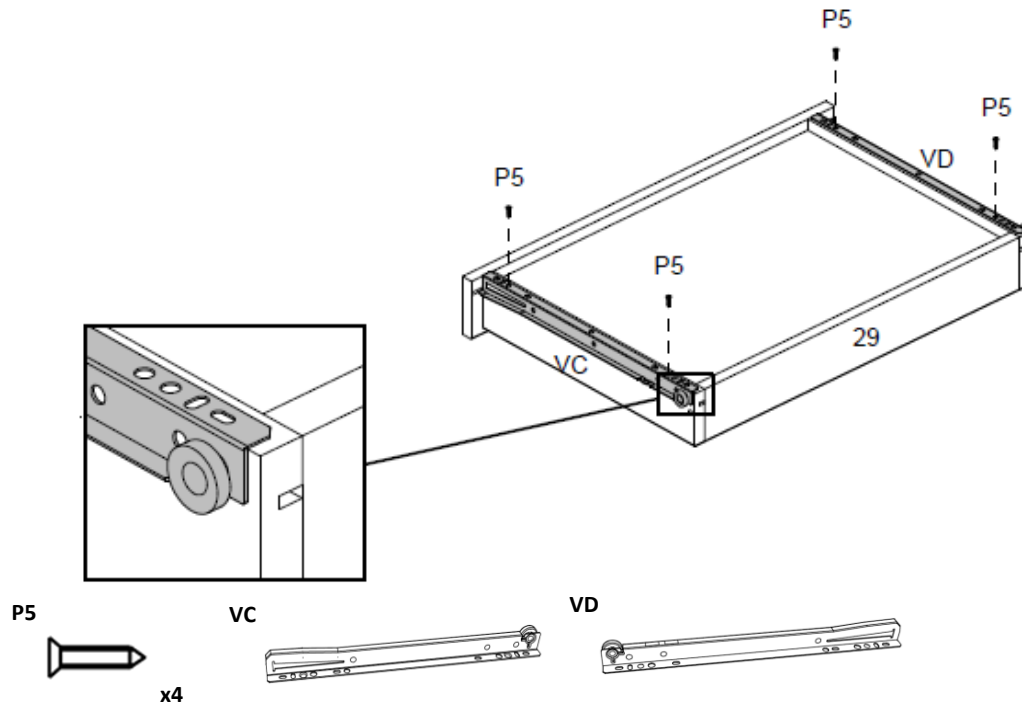

27. And finally place drawers in the furniture.

Y finalmente colocar cajones en el mueble.

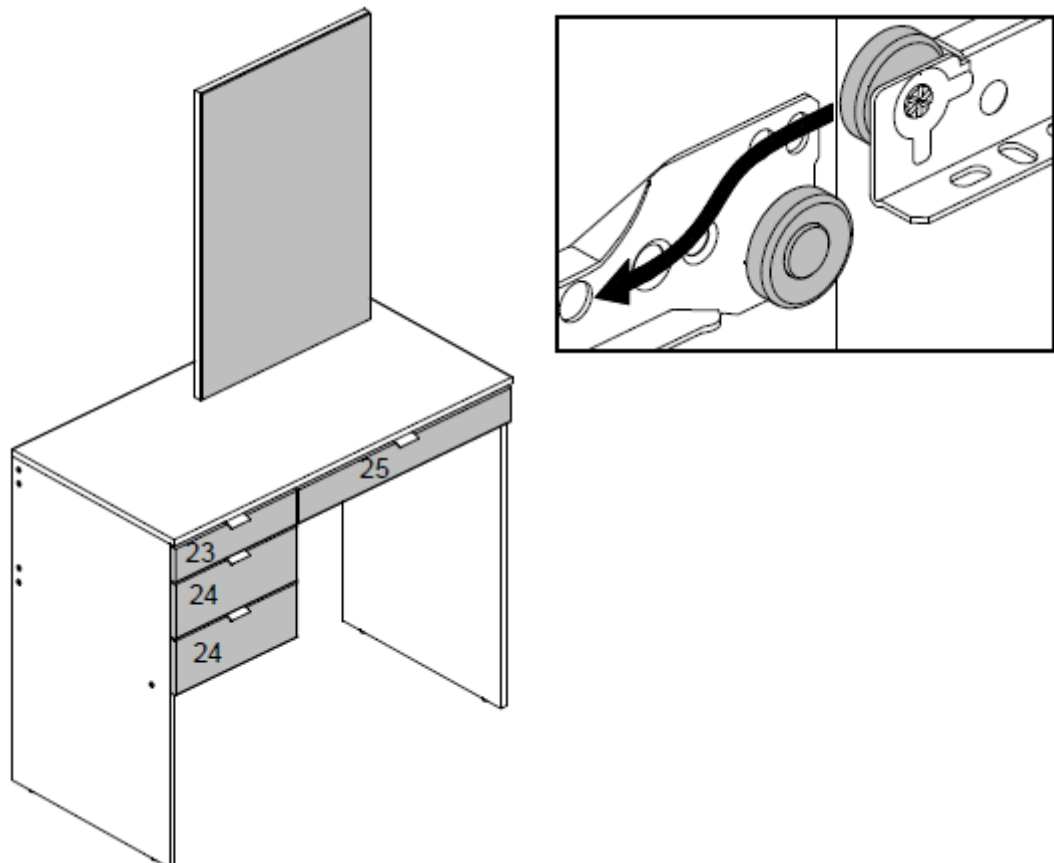

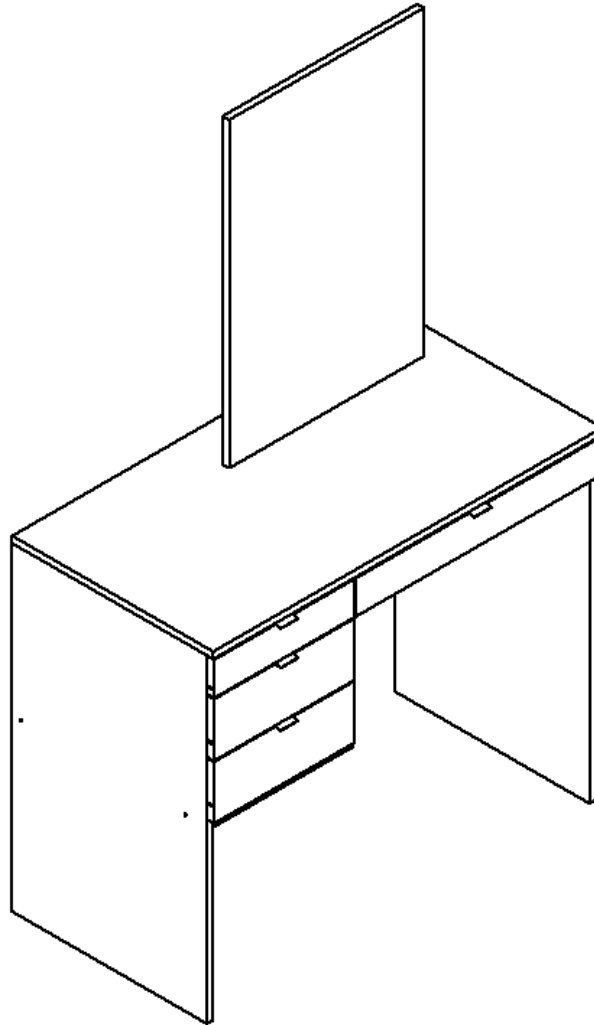

***Congratulations, you have assembled your Dressing Table with Mirror!!!  
¡¡¡Felicitaciones, has armado tu Tocador con Espejo!!!***

**1608 Boahaus Dressing Table with Mirror Warranty****6-Months Limited Warranty**

1. Boahaus, LLC provides limited warranty coverage to the original purchaser of this product for a period of six months from the date of purchase against defects in materials or workmanship of Boahaus furniture components. As used in this Warranty, “defect” means imperfections in components which substantially impair the utility of the product. This Warranty gives you specific legal rights, and you may also have other rights which vary from state to state.
2. There is no warranty coverage for defects or conditions that result from the failure to follow product assembly instructions, information or warnings, misuse or abuse, intentional damage, fire, flood, alteration or modification of the product, or use of the product in a manner inconsistent with its intended use, nor any condition resulting from incorrect or inadequate maintenance, cleaning, or care. There is also no warranty coverage for rented products or any products purchased “used” or “as is”, at a distress or going-out-of business sale, or from a liquidator.
3. As the exclusive remedy under this Warranty, Boahaus will (at its sole option) repair, replace or refund the value of any defective furniture component. Boahaus may require independent confirmation of the claimed defect and proof of purchase. Replacement parts will be warranted for only the remaining period of the original Warranty. BOAHAUS SHALL HAVE NO LIABILITY for ANY INCIDENTAL OR CONSEQUENTIAL DAMAGES OF ANY KIND and all such damages are EXCLUDED FROM THIS WARRANTY, such as loss of use, disassembly, transportation, labor or damage to property on or near the product. Some states do not allow the exclusion or limitation of incidental or consequential damages, so the above limitation or exclusion may not apply to you.
4. This Warranty applies only to warranted defects that first arise and are reported to Boahaus within the warranty coverage period. The Warranty cannot be transferred to subsequent owners or users of the product, and it shall be immediately void in the event the product is resold, transferred, leased or rented to any third party or person other than the original purchaser.
5. THERE ARE NO OTHER WARRANTIES APPLICABLE TO THIS PRODUCT. Under the laws of certain states, there may be no implied warranties from Boahaus and all implied warranties, INCLUDING ANY IMPLIED WARRANTY OF MERCHANTABILITY OR FITNESS FOR A PARTICULAR PURPOSE are disclaimed where allowed by law. TO THE EXTENT ANY IMPLIED WARRANTIES ARE APPLICABLE, ANY IMPLIED WARRANTIES, INCLUDING ANY IMPLIED WARRANTY OF MERCHANTABILITY OR FITNESS FOR A PARTICULAR PURPOSE, ARE LIMITED IN DURATION TO THE DURATION OF THIS EXPRESS WARRANTY or the minimum period allowed by law, whichever is shorter. Some states do not allow limitations on how long an implied Warranty lasts, so the above limitation may not apply to you.
6. For Warranty inquiries, questions about disposition or claims, please visit our website [www.boahaus.com](http://www.boahaus.com). You can also contact Boahaus at +1 (787) 688-1254 or email at [administracion@boahaus.com](mailto:administracion@boahaus.com). Boahaus may require Warranty claims to be submitted in writing to:

Boahaus LLC.  
1250-1252  
Ave. Franklin Delano Roosevelt,  
San Juan, PR 00926.

Please include your sales receipt or other proof of purchase and a specific description of the product defect.

**Garantía de Tocador con Espejo 1608 Boahaus****Garantía limitada de 6 meses**

1. Boahaus, LLC proporciona cobertura de garantía limitada al comprador original de este producto por un período de 6 meses a partir de la fecha de compra contra defectos en materiales o mano de obra de componentes de muebles de Boahaus. Como se especifica en esta Garantía, "defecto" significa imperfecciones en componentes que perjudican sustancialmente la utilidad del producto. Esta Garantía le otorga derechos legales específicos y también puede tener otros derechos que varían de un estado a otro.
2. No hay cobertura de garantía por defectos o condiciones que resulten del incumplimiento de las instrucciones del producto, o advertencias, uso indebido o abuso, daño intencional, incendio, inundación, alteración o modificación del producto o uso del producto de manera inconsistente con su uso previsto, o cualquier condición resultante de mantenimiento incorrecto o inadecuado, limpieza o cuidado. Tampoco hay cobertura de garantía para productos alquilados o cualquier producto comprado "usado" o "tal cual", en una venta de emergencia o de salida de la empresa, o de un liquidador.
3. Boahaus puede requerir una confirmación independiente del defecto reclamado y un comprobante de compra. Las piezas de repuesto estarán garantizadas durante el período restante de la garantía original. BOAHAUS NO TENDRÁ NINGUNA RESPONSABILIDAD POR CUALQUIER DAÑO INCIDENTAL y todos estos daños ESTÁN EXCLUIDOS DE ESTA GARANTÍA, tales como pérdida de uso, desmontaje, transporte, mano de obra o daños a la propiedad en o cerca del producto. Algunos estados no permiten la exclusión o limitación de daños incidentales o consecuentes, por lo que la limitación o exclusión anterior puede no aplicarse a usted.
4. Esta Garantía se aplica únicamente a los defectos garantizados que surgen y se informan a Boahaus dentro del período de cobertura de la garantía. La garantía no puede ser transferida a los propietarios o usuarios posteriores del producto, y será inmediatamente nula en caso de que el producto sea revendido, transferido, arrendado o alquilado a cualquier tercero o persona que no sea el comprador original.
5. NO HAY OTRAS GARANTÍAS APLICABLES A ESTE PRODUCTO. Bajo las leyes de ciertos estados, no puede haber garantías implícitas de Boahaus y todas las garantías implícitas, INCLUYENDO CUALQUIER GARANTÍA IMPLÍCITA DE COMERCIABILIDAD O ADECUACIÓN PARA UN PROPÓSITO EN PARTICULAR, están exoneradas cuando permitido por la ley. TODAS LAS GARANTÍAS IMPLÍCITAS SON APLICABLES, LAS GARANTÍAS IMPLÍCITAS, INCLUIDAS CUALQUIER GARANTÍA IMPLÍCITA DE COMERCIABILIDAD O ADECUACIÓN PARA UN PROPÓSITO PARTICULAR, ESTÁN LIMITADAS EN DURACIÓN A LA DURACIÓN DE ESTA GARANTÍA EXPRESA o el período mínimo permitido por la ley, cualquiera que sea más corto. Algunos estados no permiten limitaciones sobre la duración de una garantía implícita, por lo que es posible que la limitación anterior no se aplique a usted.
6. Para consultas sobre la garantía, preguntas sobre la disposición o reclamaciones, visite nuestro sitio web [www.boahaus.com](http://www.boahaus.com). También puede ponerse en contacto con Boahaus en +1 (787) 688-1254 o por correo electrónico en [administracion@boahaus.com](mailto:administracion@boahaus.com). Boahaus puede requerir que los reclamos de garantía sean presentados por escrito a:

Boahaus LLC.  
1250-1252  
Ave. Franklin Delano Roosevelt,  
San Juan, PR 00926.

Incluya su recibo de compra u otra prueba de compra y una descripción específica del defecto del producto.