

# boahaus

## ASSEMBLY INSTRUCTIONS

### ATTENTION!!!

Any inquiry or replacement parts  
you need, contact us directly at:

[contact@boahaus.com](mailto:contact@boahaus.com)

Scan this QR Code to contact to Customer Support Team.



Or Call Us at +1 281-809-4043

# boahaus

## ASSEMBLY INSTRUCTIONS

## INSTRUCCIONES DE ARMADO

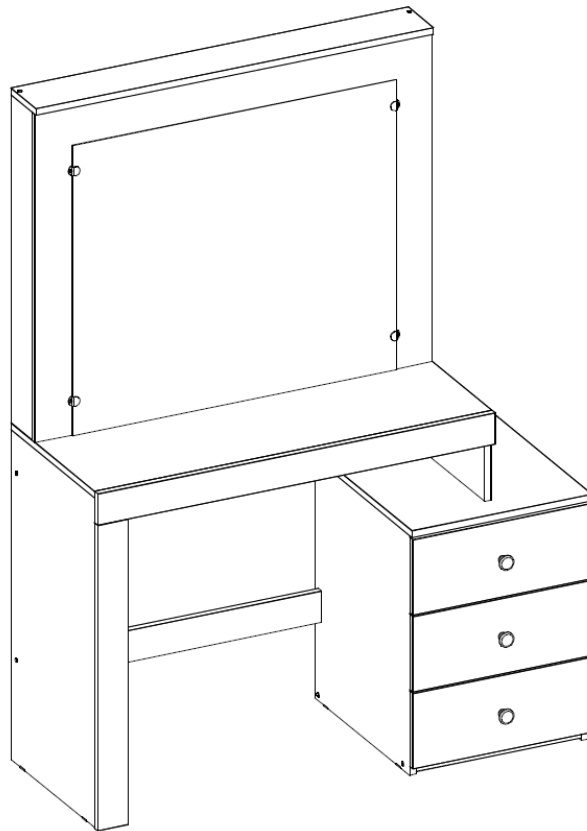

### MODEL #: 1607

#### DRESSING TABLE WITH MIRROR

Tocador con espejo

Aprox. product weight 90.52 lbs. / 41.14 Kg. \*

\*Weight may vary +/- 5%

Lot: See package

Production date: See package

Purchase date: \_\_\_\_\_

THIS INFORMATION BOOKLET CONTAINS IMPORTANT SAFETY INFORMATION. PLEASE READ AND KEEP FOR FUTURE REFERENCE.  
ESTE FOLLETO CONTIENE INFORMACIÓN DE SEGURIDAD IMPORTANTE. POR FAVOR, LEA Y GUÁRDELO PARA REFERENCIA FUTURA.

Need some Help? Call +1 281-809-4043 or email [contact@boahaus.com](mailto:contact@boahaus.com)  
¿Necesitas ayuda? Llama +1 281-809-4043 o envía un email [contact@boahaus.com](mailto:contact@boahaus.com)

## GENERAL SAFETY INFORMATION

1. Please read the Assembly Instructions prior to assembling this product.
2. Remove all the hardware from the box and sort by type.
3. Check to see that all the hardware and parts are present BEFORE assembling.
4. To avoid damage, assemble the product on a sturdy, level and protective surface.
5. Please wait until all steps are completed before fully tightening bolts.
6. Make sure all bolts are tightly fastened before the unit is used.
7. To move the product, you must lift it. DO NOT drag it, if you drag it can cause overturning.
8. **This product is sold with a hardware kit to be fixed on the wall. You must install this kit to prevent any accidents or damages. When properly installed, this restrain can provide protection against the unexpected tipping of the unit due to small tremors, bumps or climbing. The restrain is only a deterrent and is not a substitute for proper adult supervision. Use of tip-over restraints may only reduce, but not eliminate, the risk of tip-over**

## INFORMACIÓN GENERAL DE SEGURIDAD

1. Lea las instrucciones de armado antes de ensamblar este producto.
2. Extraiga todo el hardware de la caja y ordene por tipo.
3. Verifique que todo el hardware y las piezas están presentes ANTES de ensamblar.
4. Para evitar daños, ensamble el producto sobre una superficie resistente, nivelada y con protección.
5. Espere hasta que todos los pasos se hayan completado antes de apretar completamente los tornillos y accesorios.
6. Asegúrese de que todos los tornillos y accesorios estén bien apretados antes de usar la unidad.
7. Para mover el producto debe levantarlo. NO lo arrastre, si lo arrastra puede causar volcamiento.
8. **Este producto se vende con un kit de accesorios para ser fijado en la pared. Debe instalar este kit para evitar accidentes o daños. Cuando se instala correctamente, esta restricción puede proporcionar protección contra la inclinación inesperada de la unidad debido a temblores pequeños, golpes o al treparse. La restricción es solo un elemento disuasivo y no es un sustituto de la supervisión adecuada de un adulto. El uso de restricciones de vuelco solo puede reducir, pero no eliminar, el riesgo de volcarse.**



## General Dimensions / Dimensiones Generales

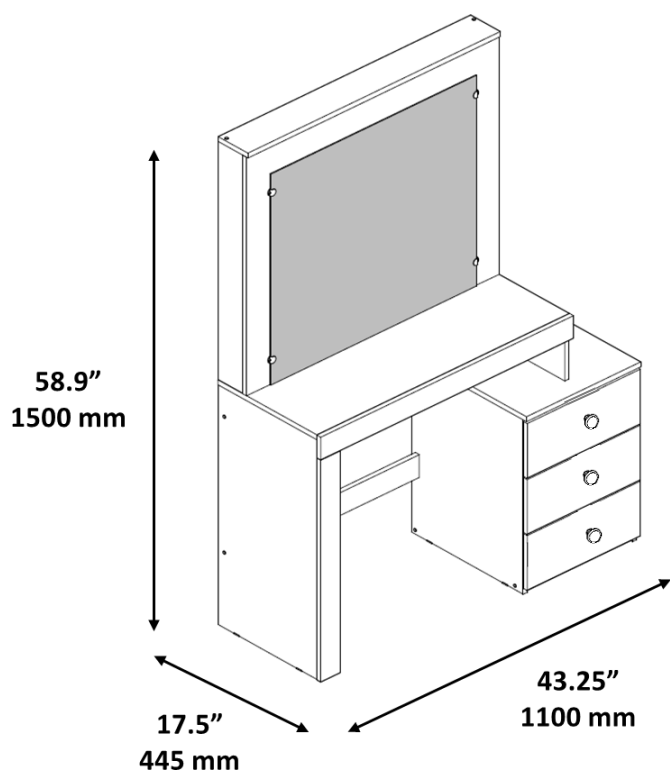

## Maximum weight supported Peso máximo soportado

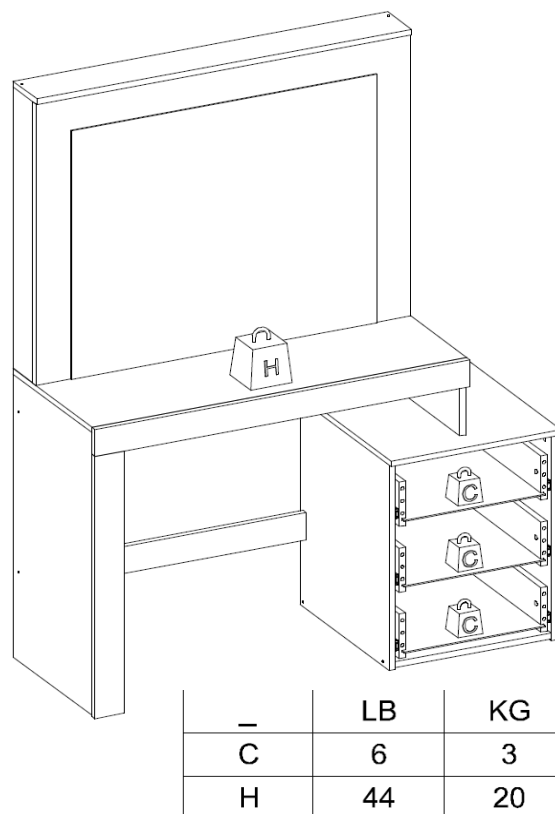

Note: weight must be evenly distributed.  
Nota: el peso debe estar distribuido uniformemente.

## You will need / usted necesitará:

Tools not included / herramientas no incluidas



2 people  
2 personas

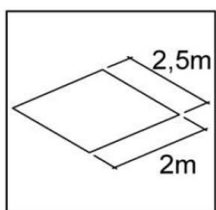

Recommended space for assembly  
Espacio recomendado para el armado

**Note:** Place a carpet or blanket in the assembly area to avoid damage to the parts during the process.  
**Nota:** Colocar una alfombra o manta en el area de armado para evitar daños en las piezas durante el proceso.

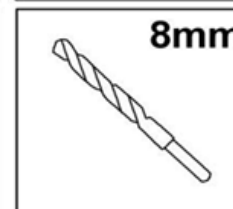
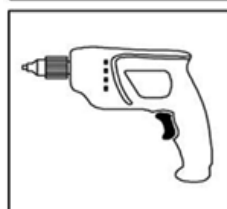
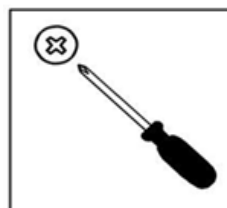

The drill will be used **ONLY** to fix the furniture to the wall.  
El taladro será usado **SOLO** para fijar el mueble a la pared.

## PARTS IDENTIFICATION / IDENTIFICACION DE PARTES



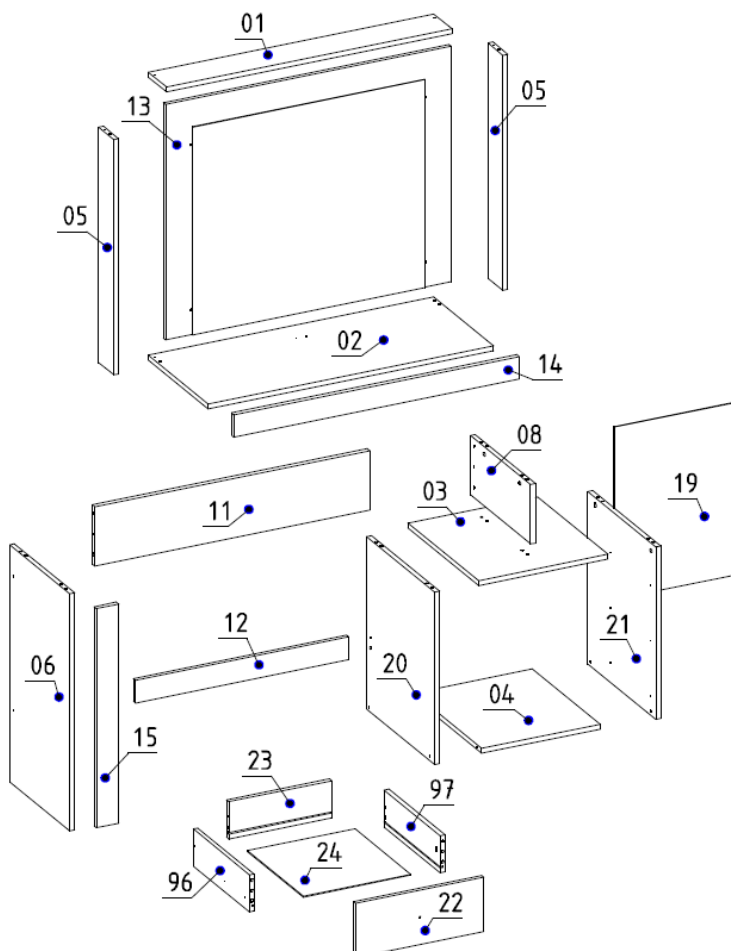







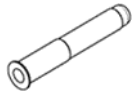
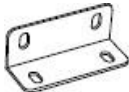

Nº	DESCRIPTION - DESCRIPCIÓN	QTY.
01	Top tray / Traviesa superior	1
02	Top base / Base superior	1
03	Intermediate base / Base intermedia	1
04	Bottom base / Base inferior	1
05	Side tray / Traviesa lateral	2
06	Left side / Lateral izquierdo	1
08	Top base support / Soporte de base superior	1
11	Back panel / Panel trasero	1
12	Crossbeam / Travesaño trasero	1
13	Mirror panel / Espejo	1
14	Horizontal frame / Marco horizontal	1
15	Vertical frame / Marco horizontal	1
19	Backboard / Fondo trasero	1
20	Partition / División	1
21	Right side / Lateral derecho	1
22	Front of drawer / Frontal de cajón	3
23	Back of drawer / Trasero de cajón	3
24	Bottom of drawer / Fondo de cajón	3
96	Left side of drawer / Lateral izquierdo de cajón	3
97	Right side of drawer / Lateral derecho de cajón	3



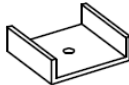

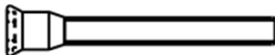

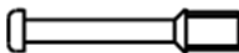

Need some Help? Call +1 281-809-4043 or email [contact@boahaus.com](mailto:contact@boahaus.com)  
 ¿Necesitas ayuda? Llama +1 281-809-4043 o envía un email [contact@boahaus.com](mailto:contact@boahaus.com)

**IDENTIFICATION OF ACCESSORIES / IDENTIFICACION DE ACCESORIOS**

**Note: the separation of the accessories before starting the assembly will facilitate it.  
Nota: la separación de los accesorios antes de empezar el armado facilitará el mismo.**

CODE		DESCRIPTION	QTY
A		Flanged head screw / Tornillo cabeza flangeada (5 x 60 mm)	1
A1		Glue / Pegamento	1
B3		Bushing / Tapón	1
B5		Metallic angle plate / Soporte de metal	11
B6		Junctions plates / Chapa de unión	1
E		Wooden dowel / Pin	34
E4		Mirror support / Soporte espejo	4
E7		Small plastic foot / Pie plástico	6
E9		Strap / Correa	1
F		Wooden dowel / Pin (8 x 50 mm)	2
G		Structural screw / Tornillo estructural (5x 50 mm)	12
H		Allen key / Llave allen	1
H18		Knob / Tirador	3
I		Structural screw cover / Tapa de tornillo estructural	9
J		Simple minifix screw / Tornillo minifixsimple	14

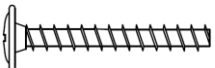
L		Drum lock / Tambor minifix	14
L17		Telescopic slide / Corredera telescópica	6
M		Bore patch adhesive / Tapón adhesivo	6
N		Nail / Clavo	22
O		Flat head screw / Tornillo cabeza plana(4,5 x 45 mm)	08
P5		Flat head screw / Tornillo cabeza plana(3,5 x 14 mm)	24
S		Pan head screw / Tornillo cabeza redondeada (3,5 x 14 mm)	53
T		Flanged head screw / Tornillo cabeza flangeada	3



# ATTENTION

To facilitate the assembly process, separate and organize all boards before you start.



Para facilitar el armado, separa y organiza todas las tablas antes de empezar.





**PRE-ASSEMBLY / PRE- ARMADO**

1. Fix *simple minifix screw* (J) to *top base* (02).  
Fijar *tornillo minifix simple* (J) a *base superior* (02).

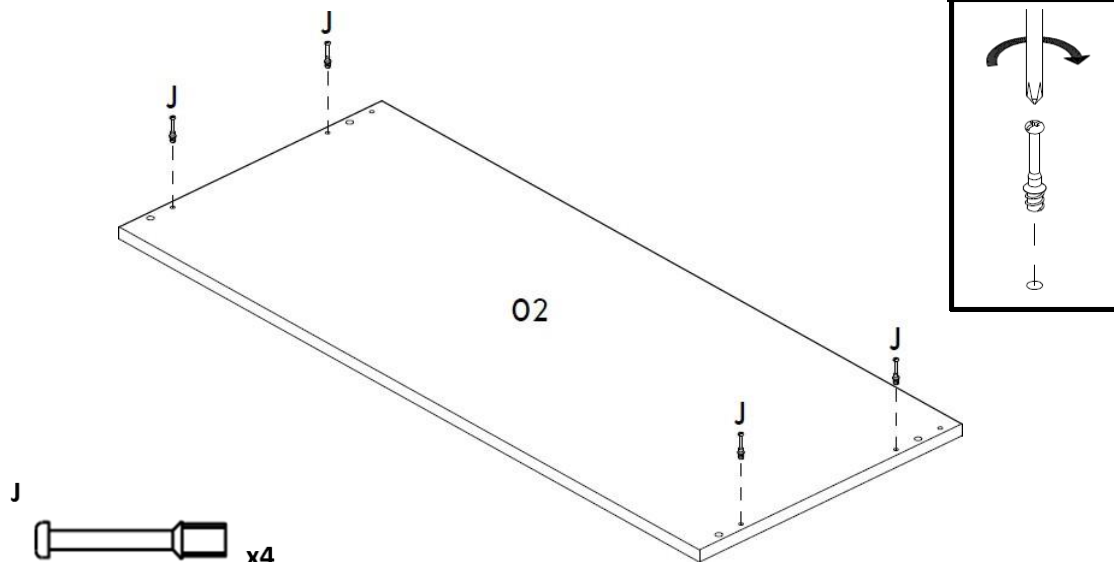

2. Fix *mirror support* (E4) to *mirror* (13).  
Fijar *sopORTE espejo* (E4) a *espejo* (13).

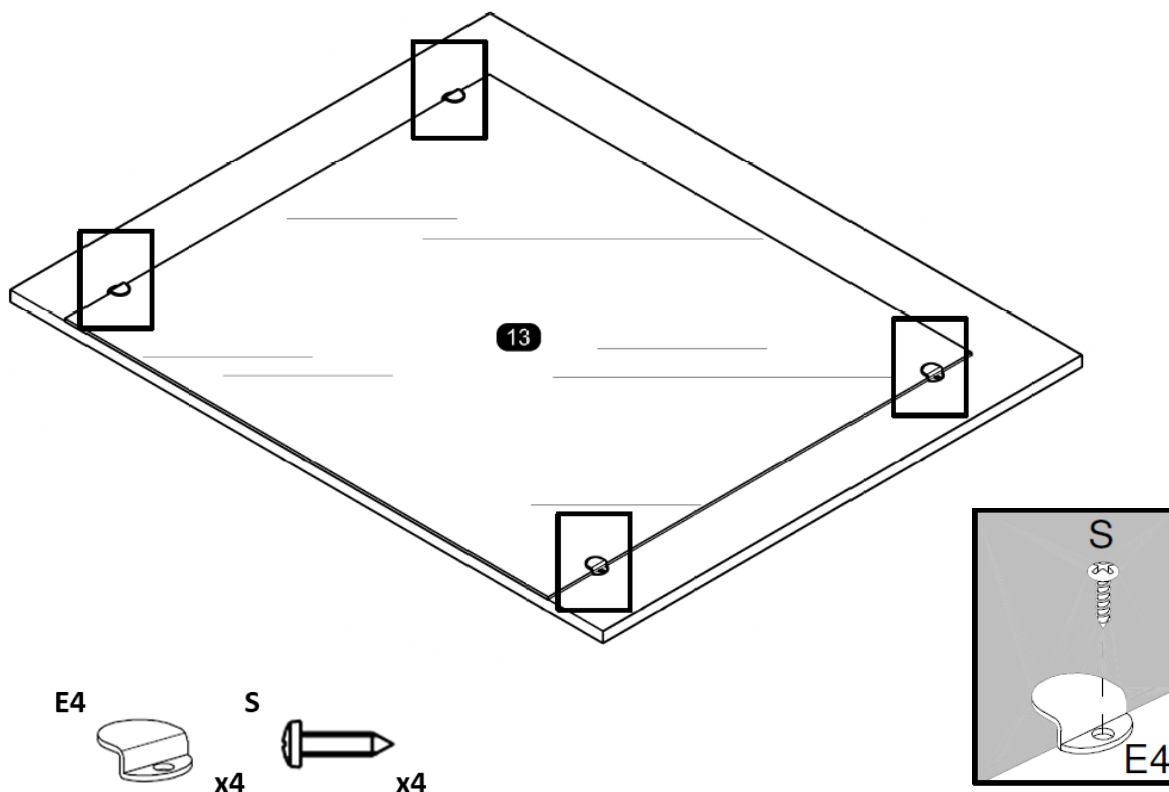

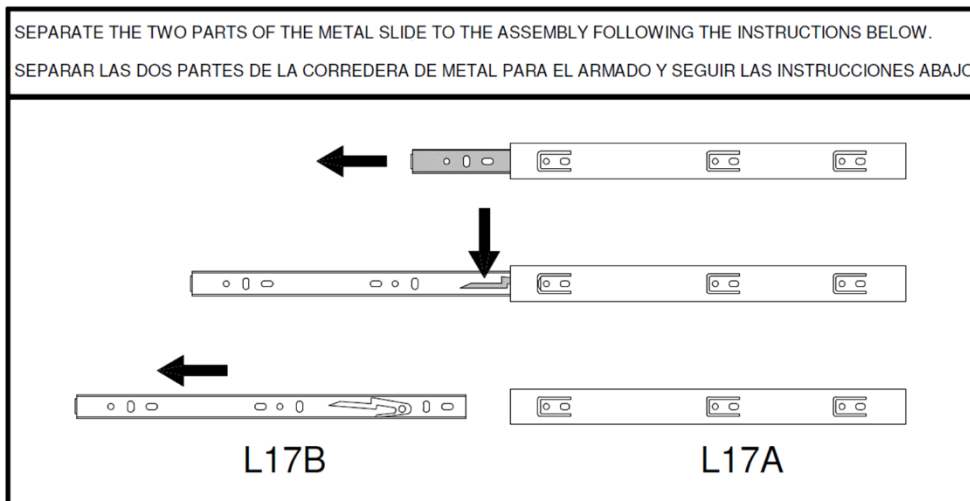

3. Fix **wooden dowel** (E) and **telescopic slide** (L17A) to **division** (20).  
 Fijar **pin** (E) y **corredera telescópica** (L17A) a **división** (20).

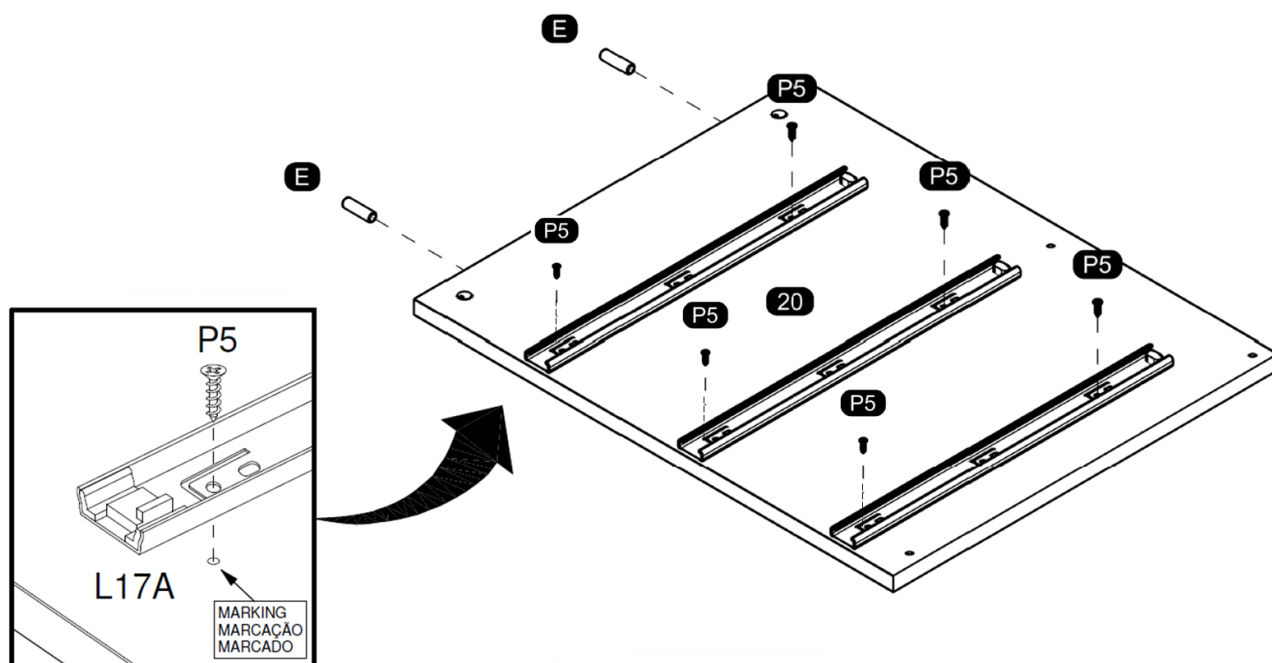

4. Fix **wooden dowel** (E) and **telescopic slide** (L17A) to **right side** (21).  
 Fijar **pin** (E) y **corredera telescópica** (L17A) a **lateral derecho** (21).

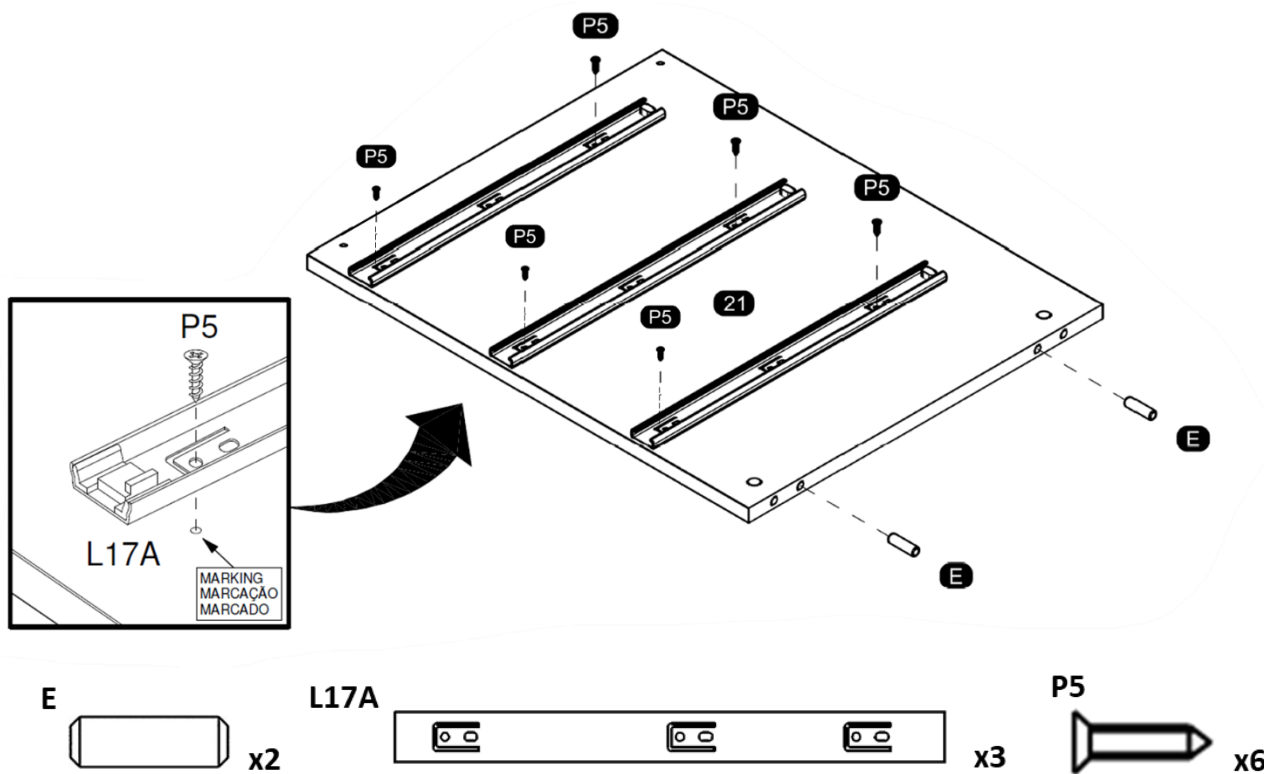

5. Insert **wooden dowel** (E) to **left side** (6).  
 Inserte el **pin de madera** (E) a **lateral izquierdo** (6)

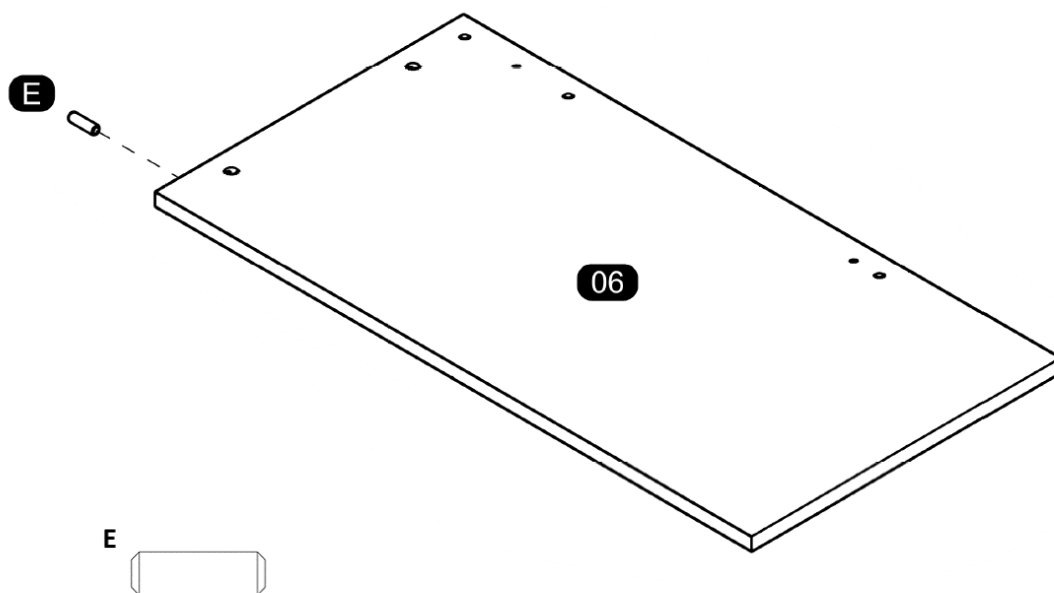

6. Fix **wooden dowel** (E) and **wooden dowel** (F) to **side tray** (05) x2.  
 Fijar **pin** (E) y **pin** (F) a **travesaño lateral** (05) x2.

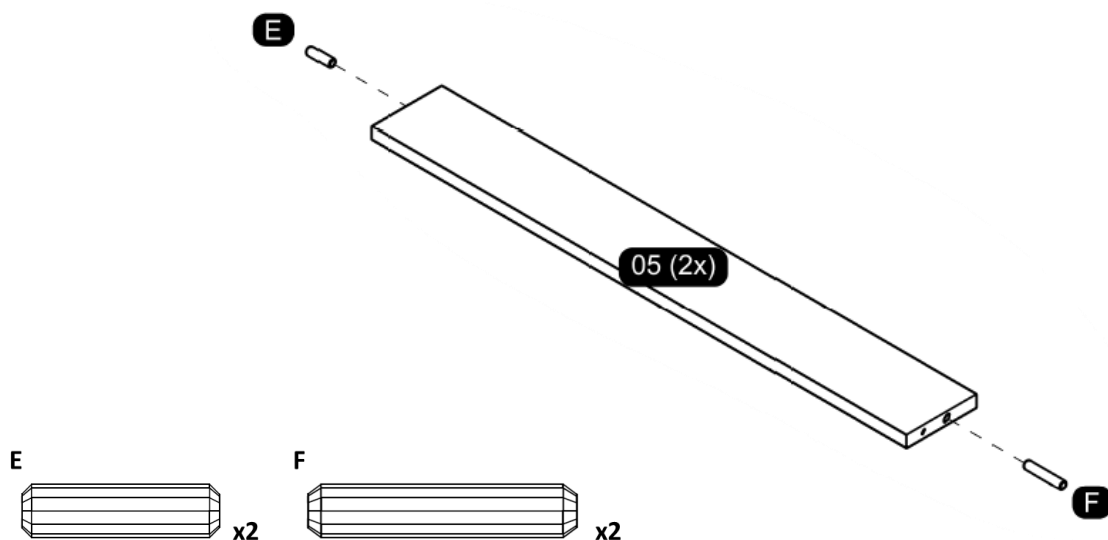

7. Fix **wooden dowel** (E) to **back panel** (11) and **top base support** (08).  
 Fijar **pin** (E) a **panel trasero** (11) y **soporte de base superior** (08).

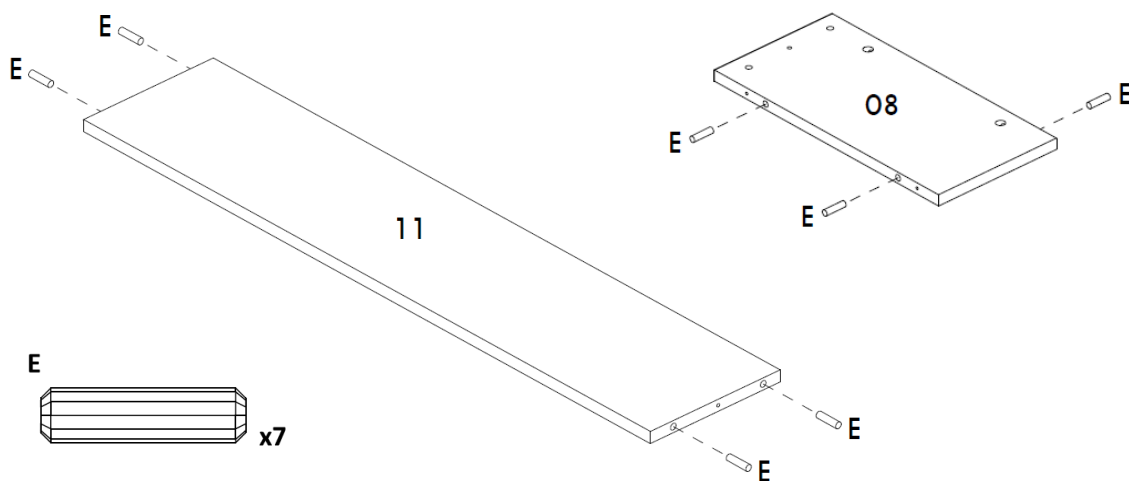

8. Fix **wooden dowel (E)** to **left side of drawer (96)** x3 and **right side of drawer (97)** x3.  
 Fijar **pin (E)** a **lateral izquierdo de cajón (96)** x3 y **lateral derecho de cajón (97)** x3.

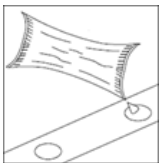
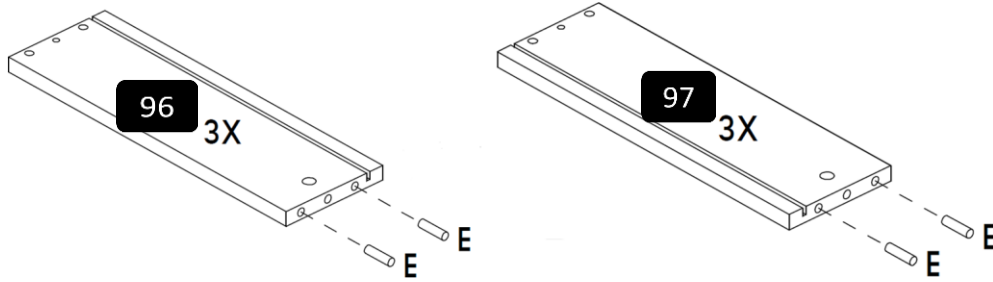

**Note:** add glue in the holes before placing the wooden dowel.  
**Nota:** agregue el pegamento en los agujeros antes de colocar el pin.

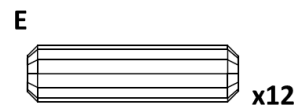

9. Fix **wooden dowel (E)** to **back of drawer (23)** x3.  
 Fijar **pin (E)** a **posterior de cajón (23)** x3.

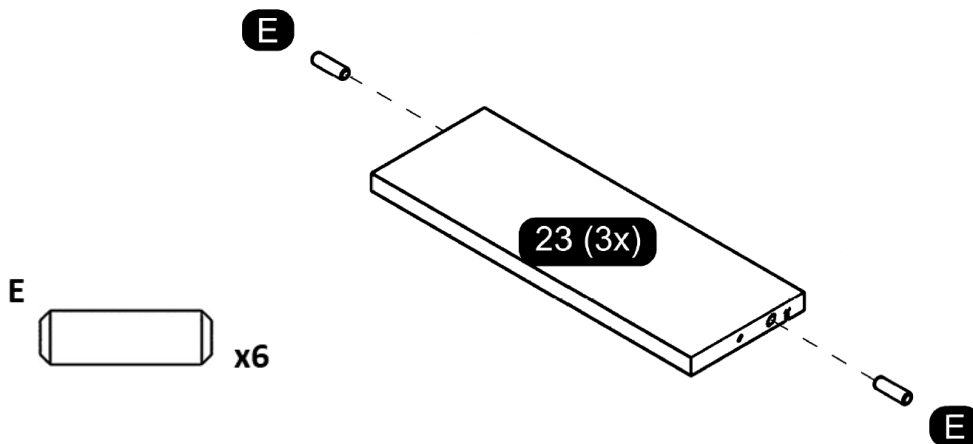

10. Fix **simple minifix screw (J)** and **knob (H18)** to **front of drawer (22)** x3.  
 Fijar **tornillo minifix simple (J)** y **tirador (H18)** a **frontal de cajón (22)** x3.

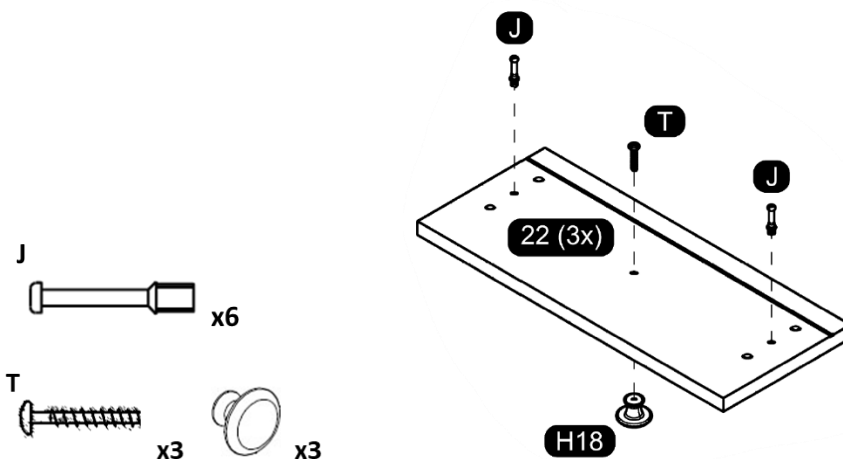

11. Fix **wooden dowel** (E) to **crossbeam** (12).

Fijar **pin** (E) a **travesaño trasero** (12).

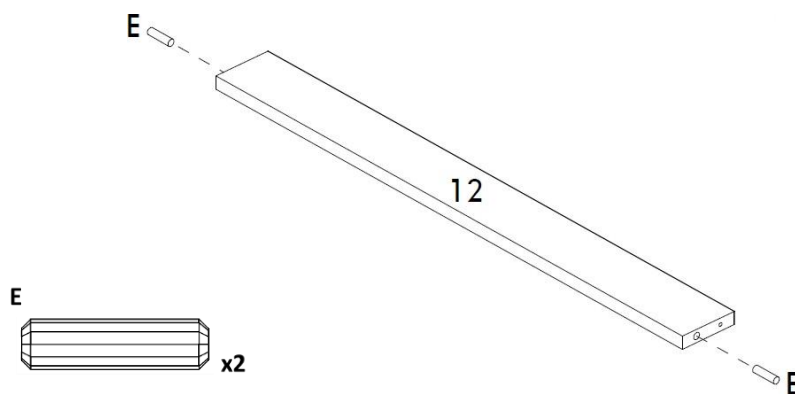

12. Fix **metallic angle plate** (B5) to **horizontal frame** (14) and **vertical frame** (15).

Fijar **soporte de metal** (B5) a **marco horizontal** (14) y **marco vertical** (15).

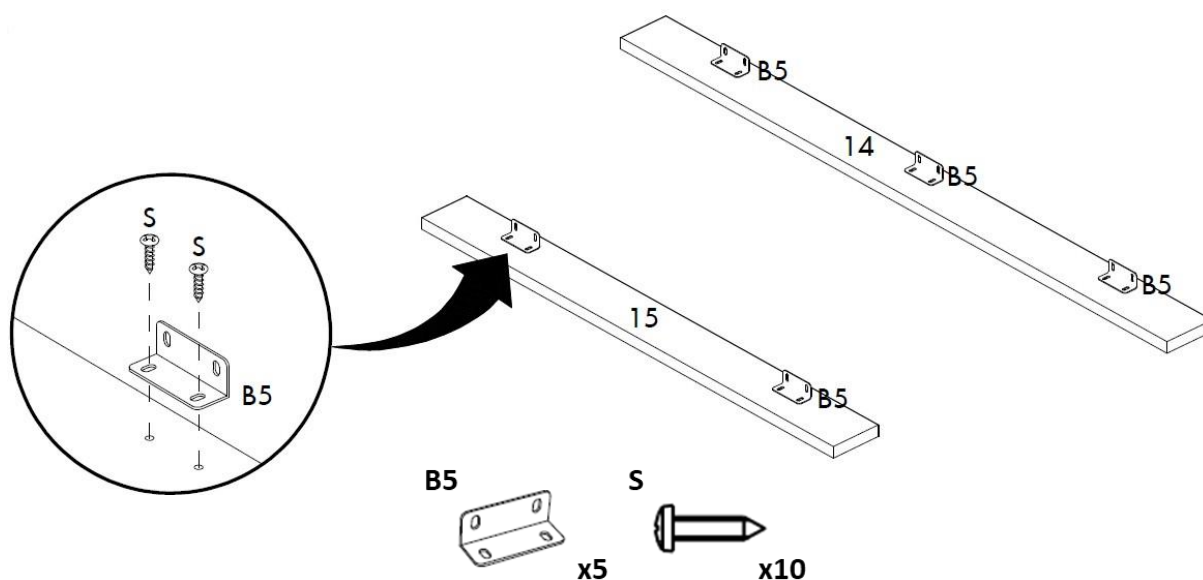

13. Fix **simple minifix screw** (J) to **intermediate base** (03).

Fijar **tornillo minifix simple** (J) a **base intermedia** (03).

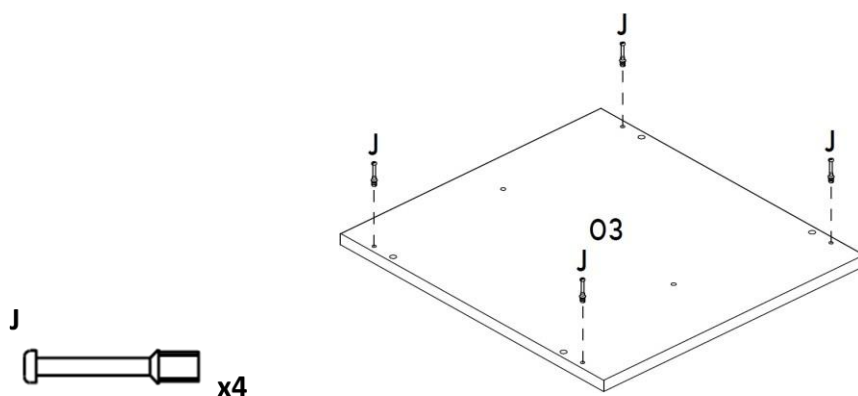

**ASSEMBLY / ARMADO**

14. Fix **side tray** (05) x2 to **top tray** (01).

Fijar **travesaño lateral** (05) x2 a **travesaño superior** (01).

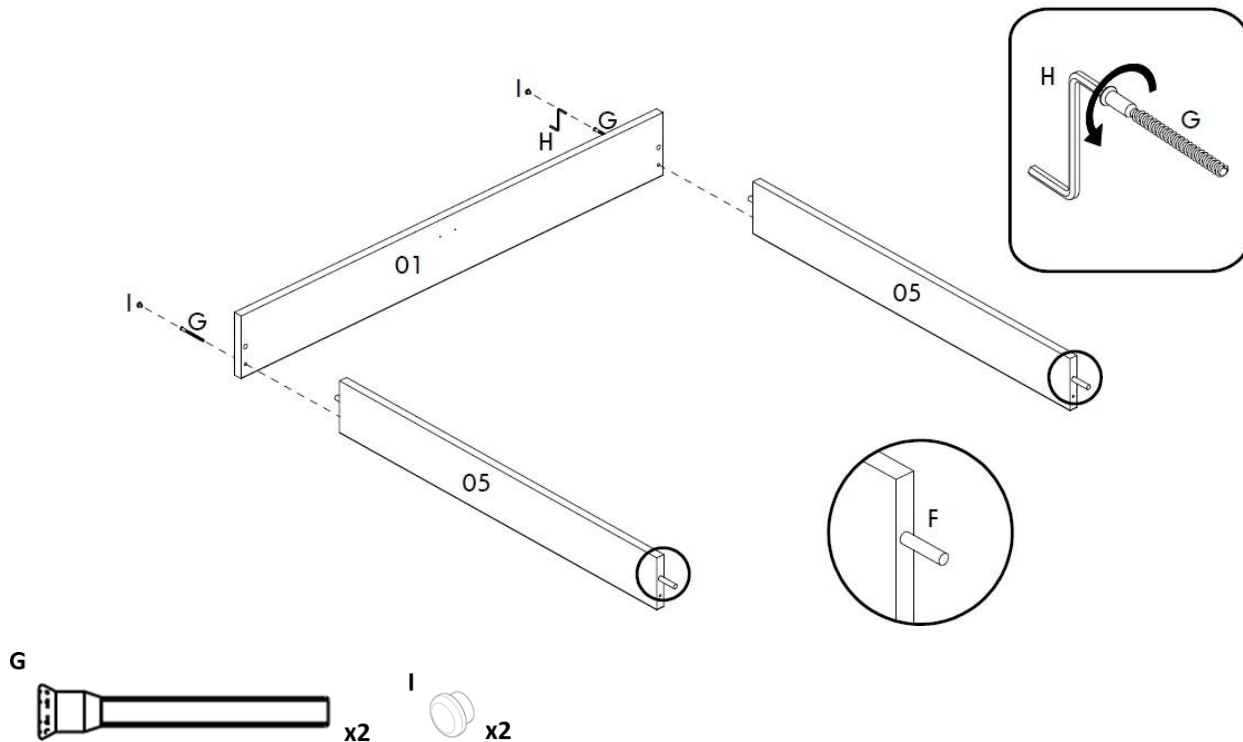

15. Fix **top base** (02) to previous assembly.

Fijar **base superior** (02) a ensamble previo.

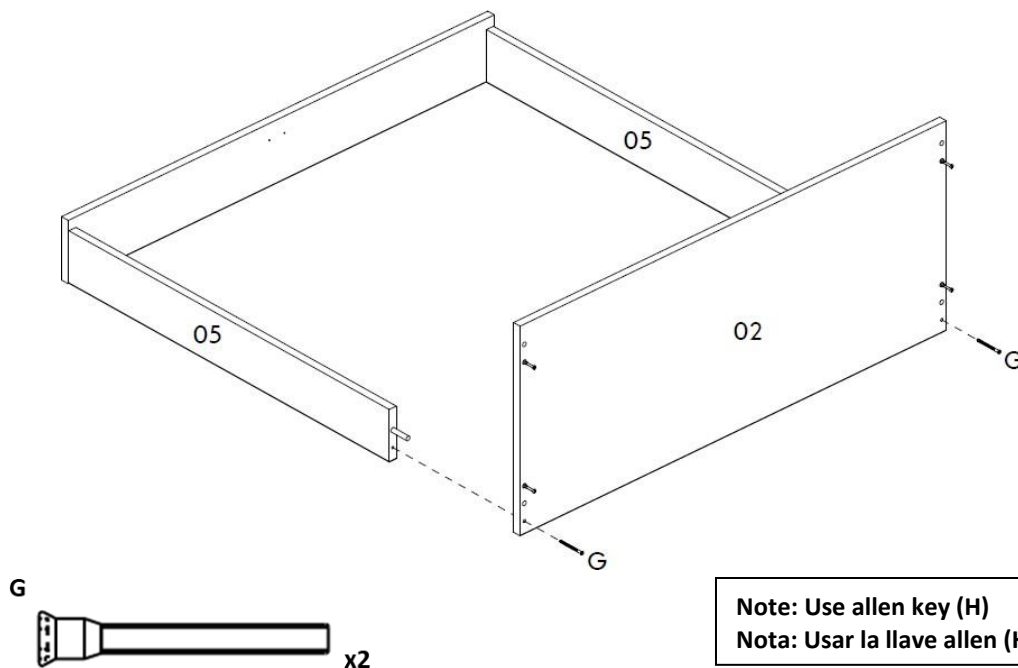

**Note: Use allen key (H)**  
**Nota: Usar la llave allen (H)**

16. Fix **right side** (21) and **partition** (20) to **bottom base** (04).  
 Fijar **lateral derecho** (21) y **división** (20) a **base inferior** (04).

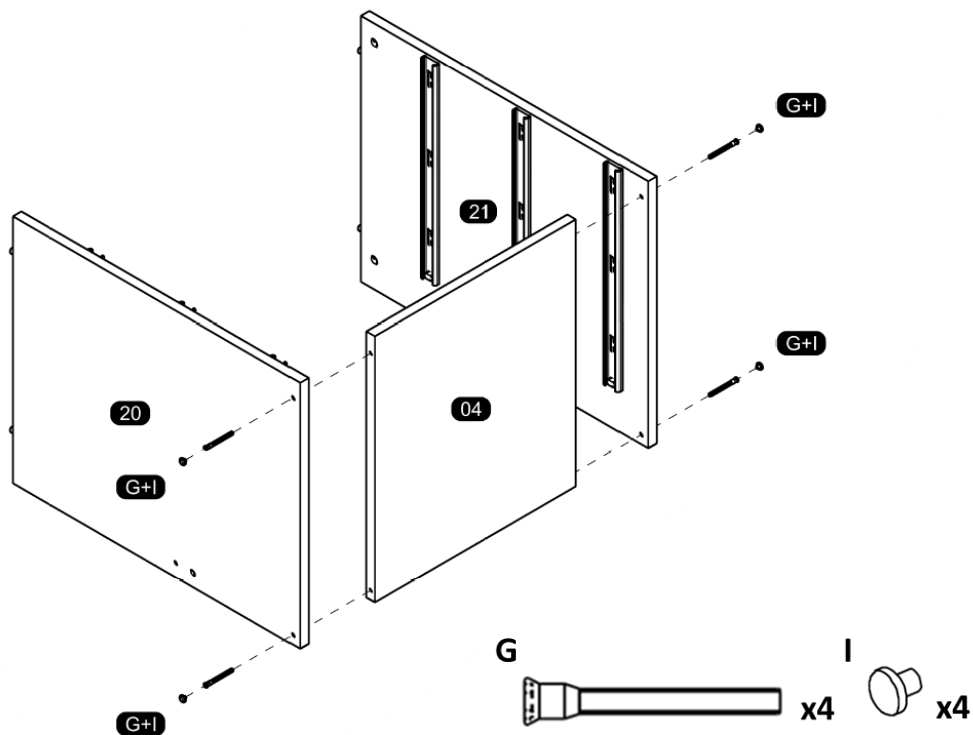

17. Fix **back panel** (11) to **intermediate base** (08).  
 Fijar **panel trasero** (11) a **base intermedia** (08).

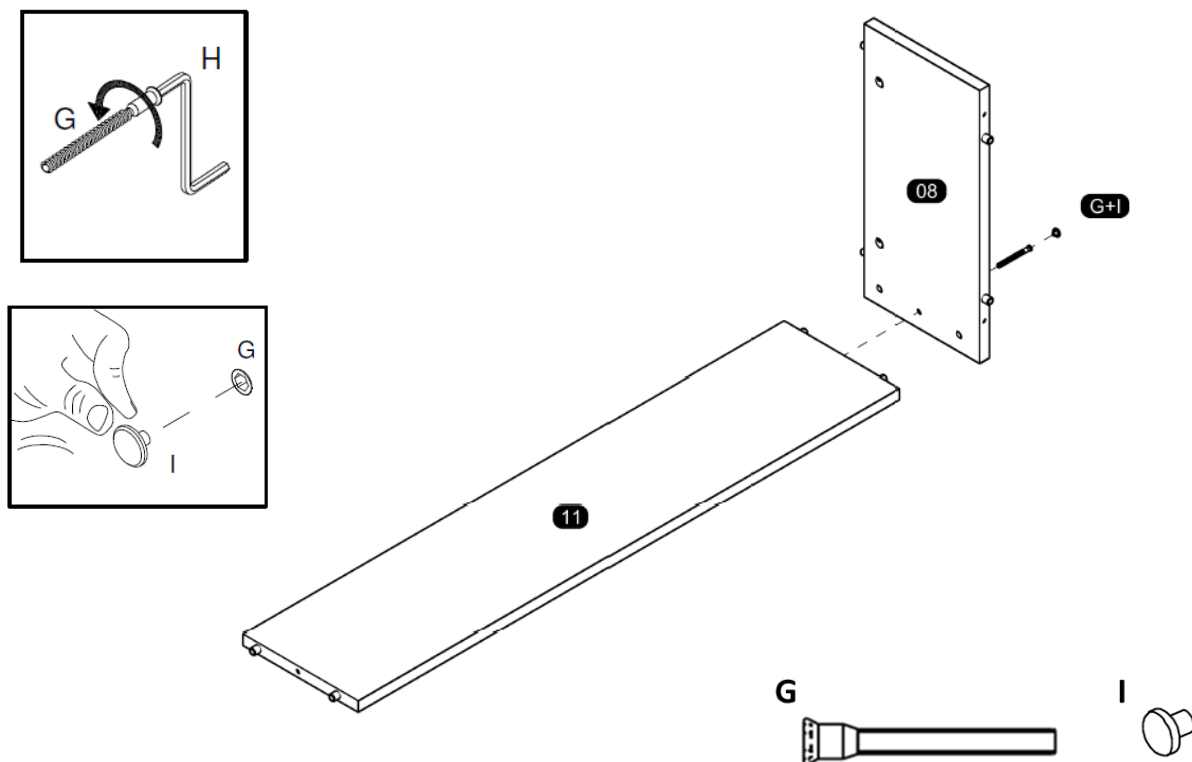



18. Fix *intermediate base* (03) to previous assembly.  
 Fijar *base intermedia* (03) a ensamble previo.

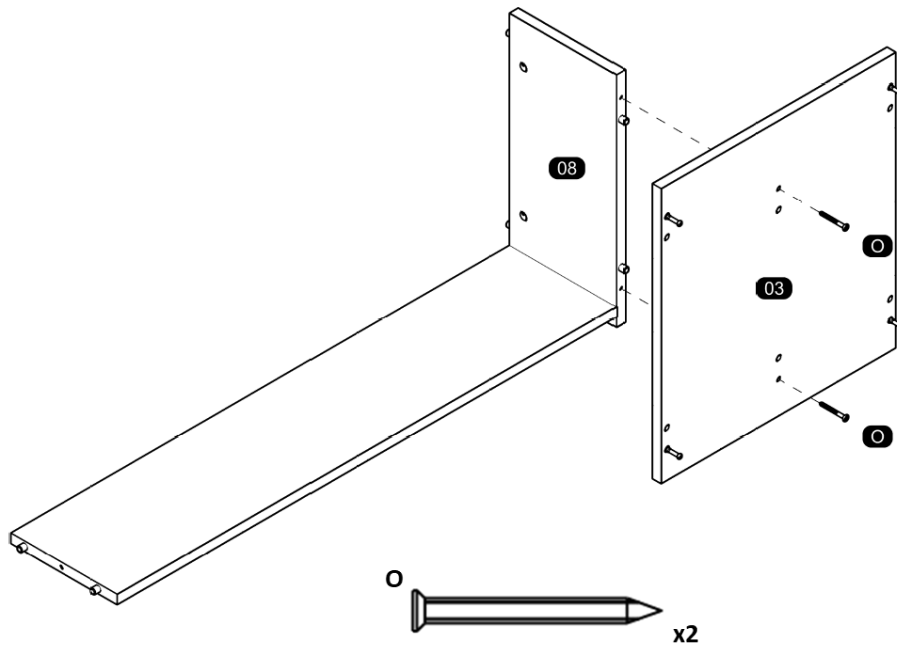

19. Join step 16 and step 18.  
 Unir pasos 16 y 18

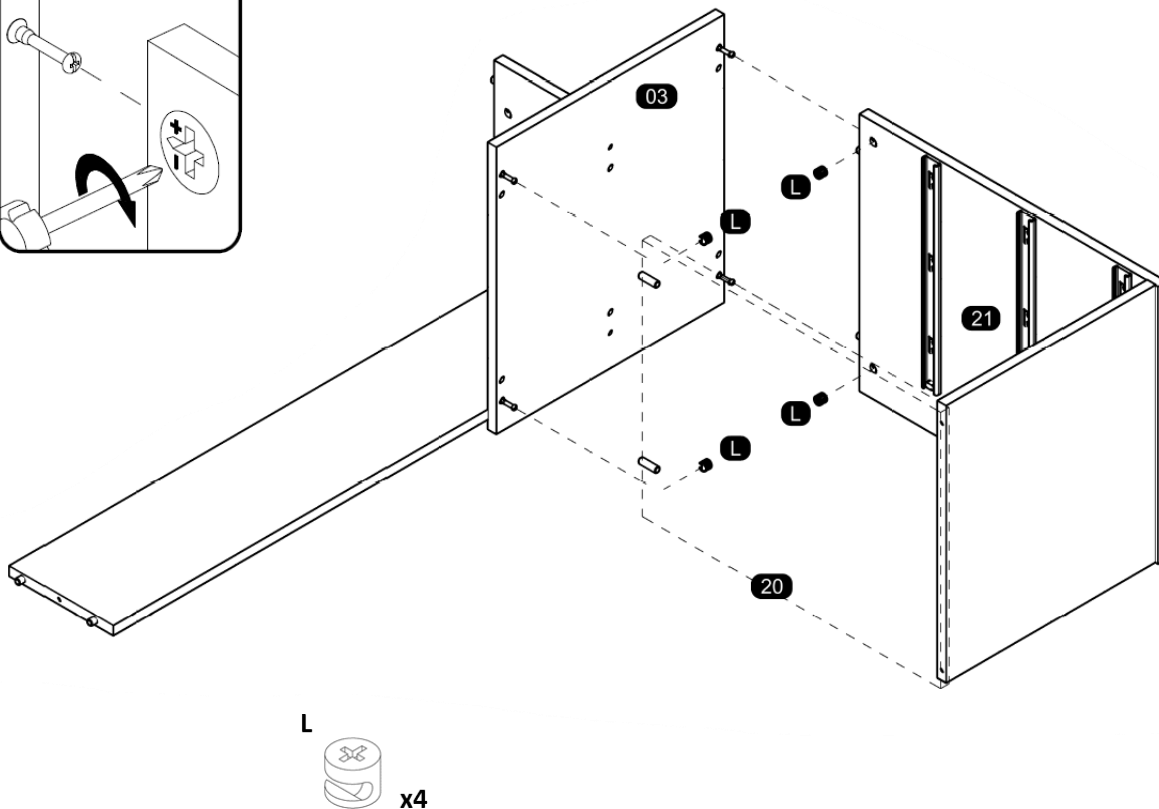
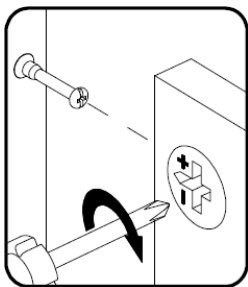

20. Fix **left side** (06) and **crossbeam** (12) to previous assembly.

Fijar **lateral izquierdo** (06) y **travesaño trasero** (12) a ensamble previo.

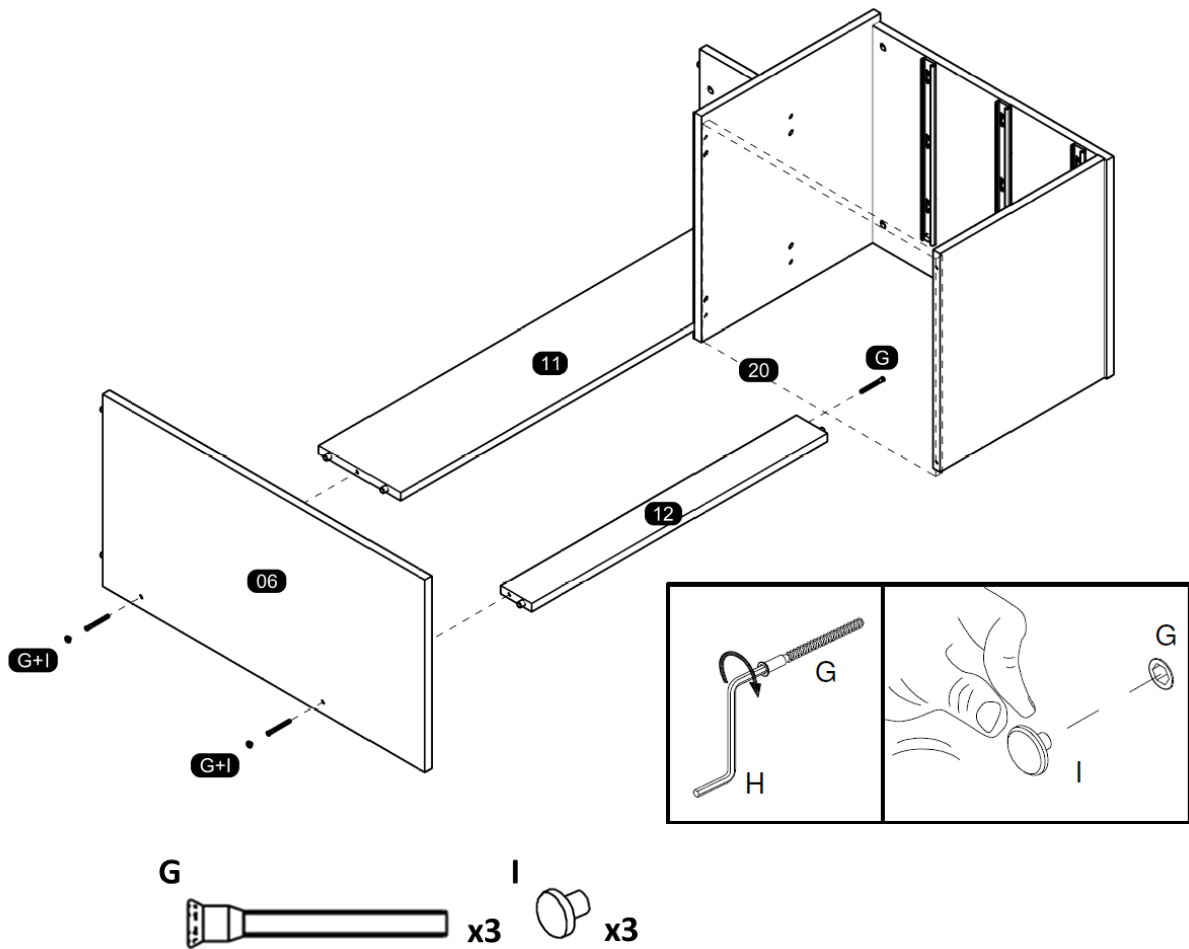

21. Join *step 15 and step 20.*  
 Una el *paso 15 y paso 20.*

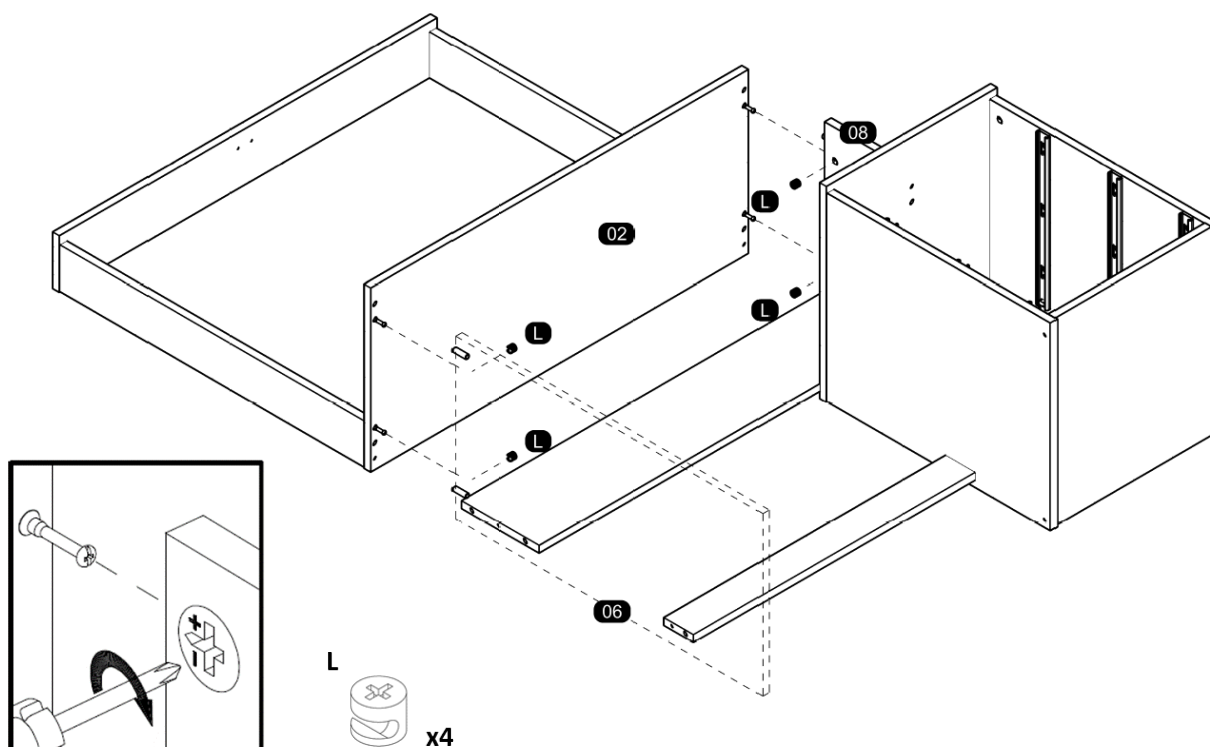

22. Fix *horizontal frame (14) and vertical frame (15).*  
 Fijar *marco horizontal (14) y marco vertical (15).*

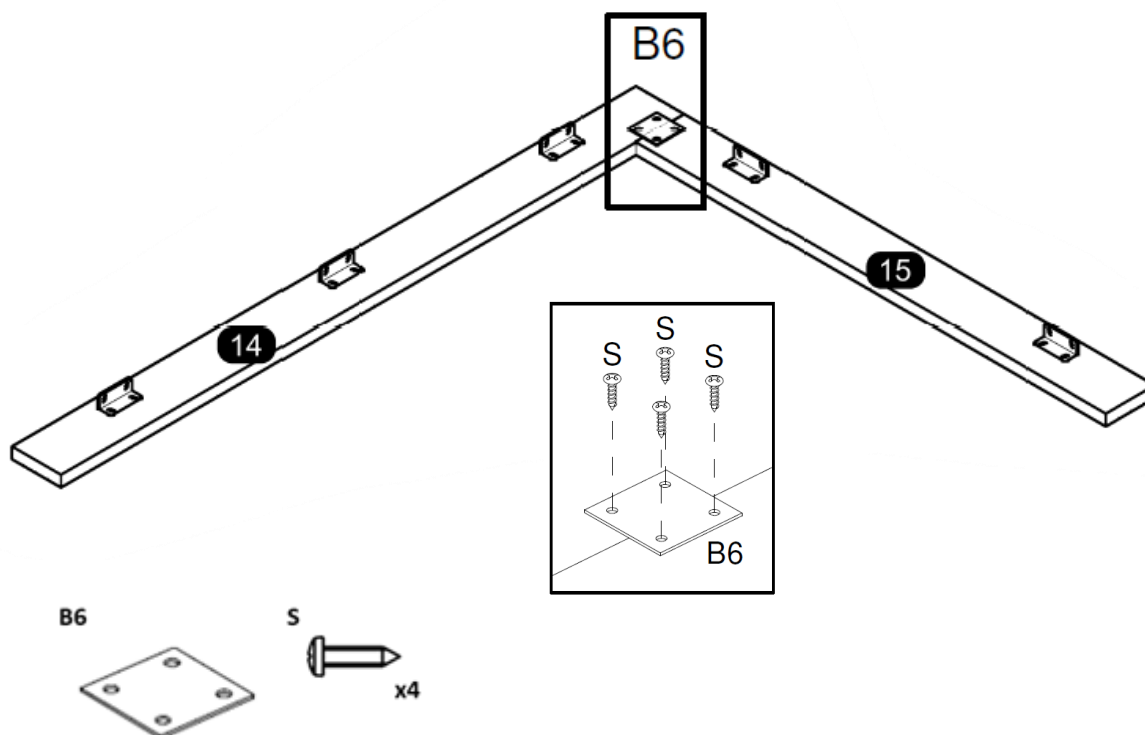

Need some Help? Call +1 281-809-4043 or email [contact@boahaus.com](mailto:contact@boahaus.com)  
 ¿Necesitas ayuda? Llama +1 281-809-4043 o envía un email [contact@boahaus.com](mailto:contact@boahaus.com)

23. Fix previous step to full assembly.  
Fijar el paso previo al ensamble completo.

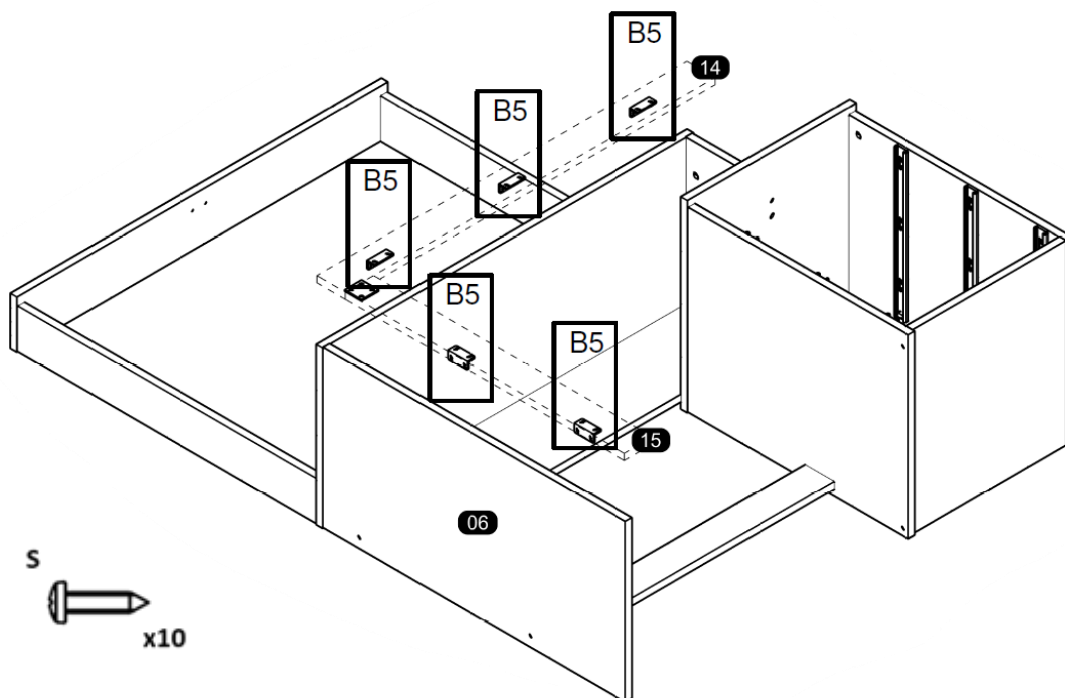

24. Fix **plastic foot** (E7) to previous assembly.  
Fijar **pie plástico** (E7) a ensamble previo.

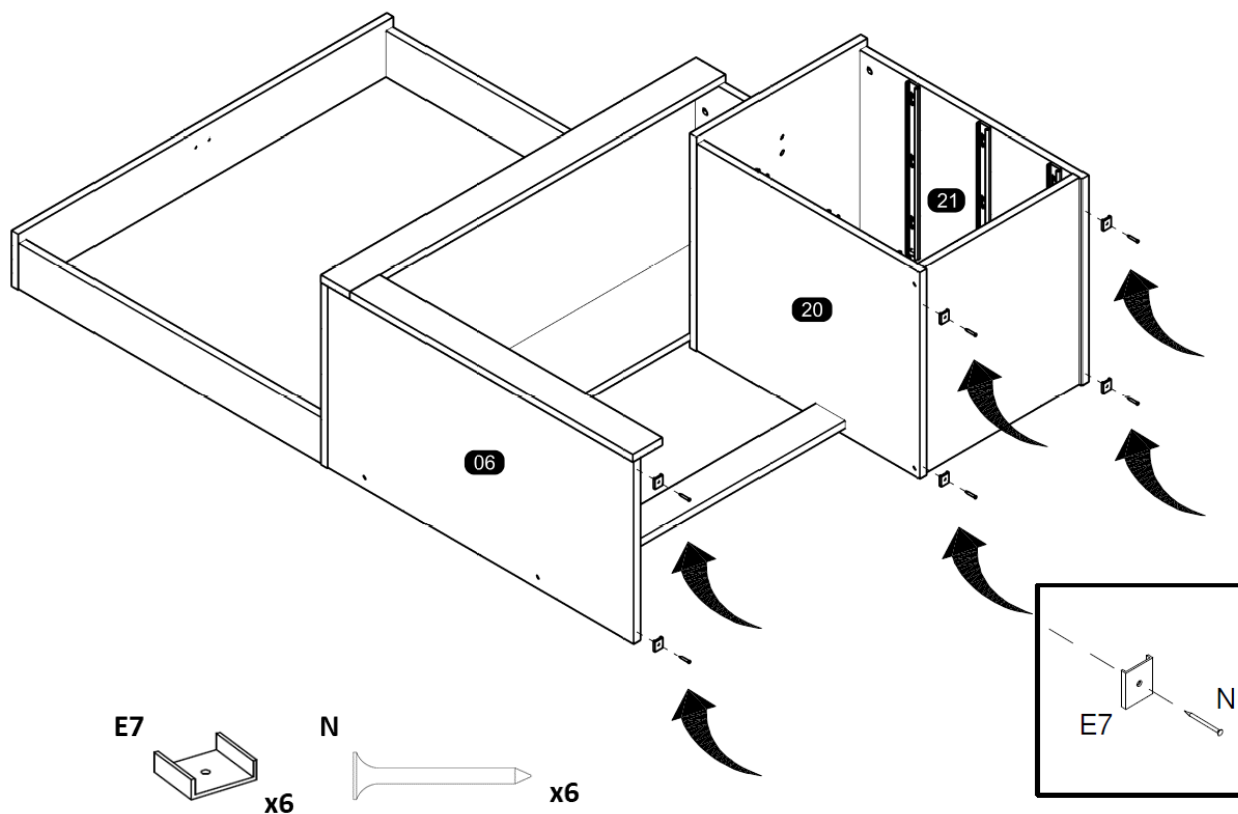

25. Fix **mirror** (13) to previous assembly.  
 Fijar **mirror** (13) a ensamble previo

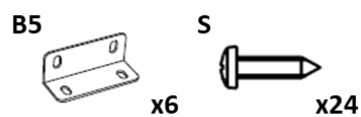
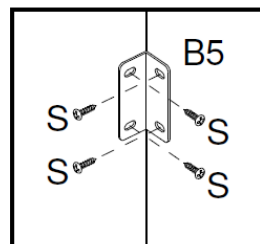
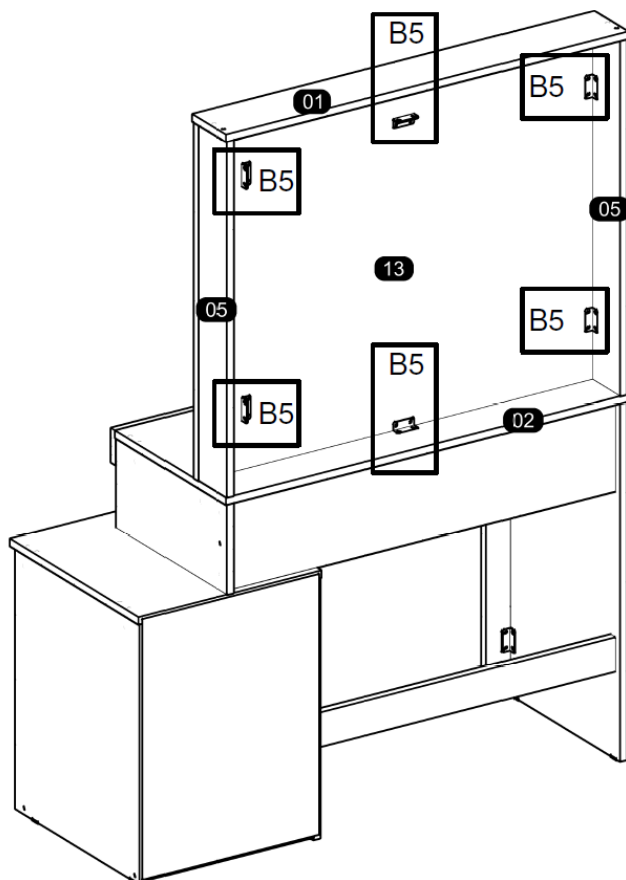

26. Fix **backboard** (19) to previous assembly.  
 Fijar **fondo** (19) a ensamble previo.

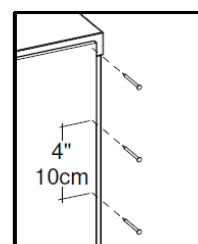
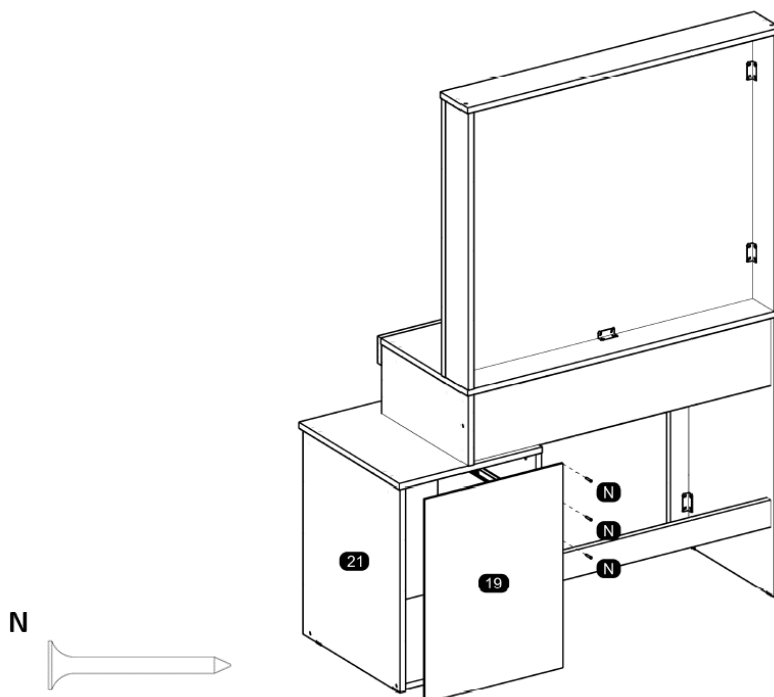

Need some Help? Call +1 281-809-4043 or email [contact@boahaus.com](mailto:contact@boahaus.com)  
 ¿Necesitas ayuda? Llama +1 281-809-4043 o envía un email [contact@boahaus.com](mailto:contact@boahaus.com)

27. Assemble drawer x3.  
Ensamblar cajón x3.

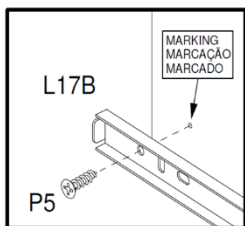
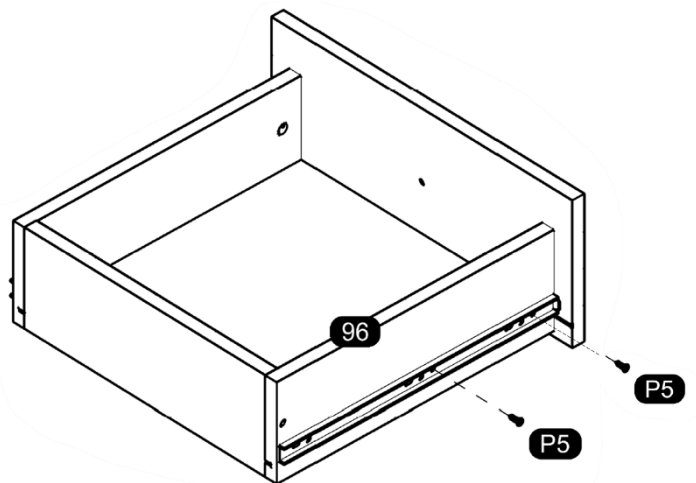
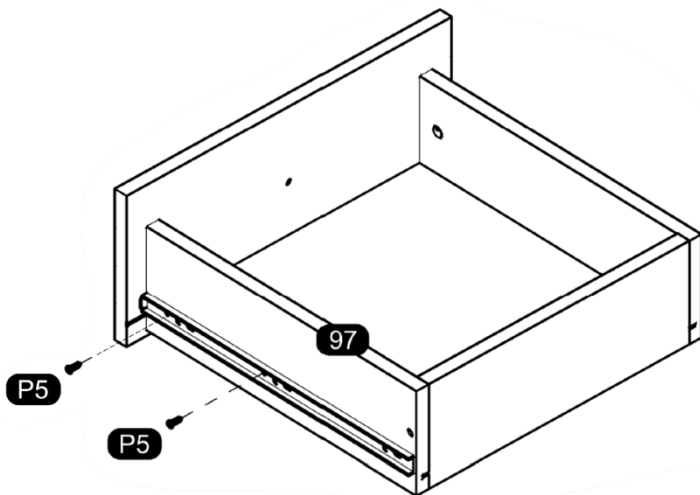
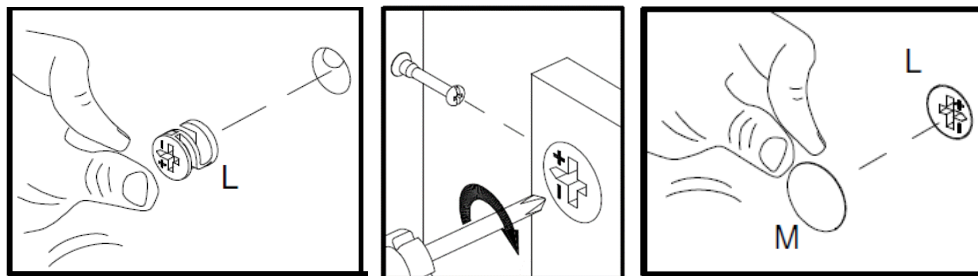
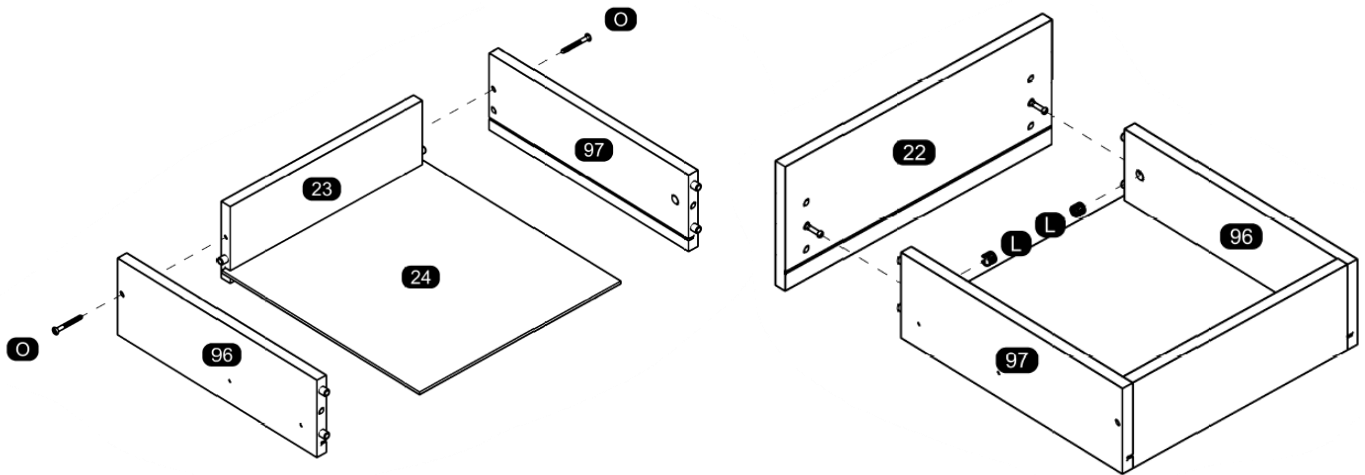

L17B



x6

P5



x12

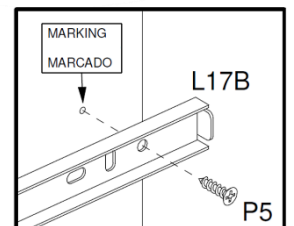

Need some Help? Call +1 281-809-4043 or email [contact@boahaus.com](mailto:contact@boahaus.com)  
¿Necesitas ayuda? Llama +1 281-809-4043 o envía un email [contact@boahaus.com](mailto:contact@boahaus.com)

28. Fix furniture to the wall.  
Fijar el mueble a la pared.

TO AVOID ANY INJURY THE FURNITURE MUST BE FIXED ON THE WALL. THANKS.  
PARA EVITAR CUALQUIER ACCIDENTE ES OBLIGATORIO ANCLAR EL MUEBLE EN LA PARED. GRACIAS.

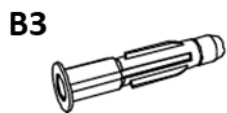
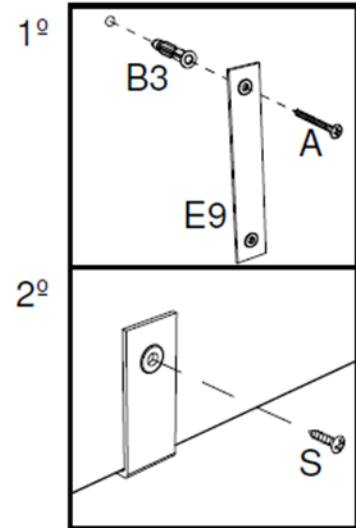
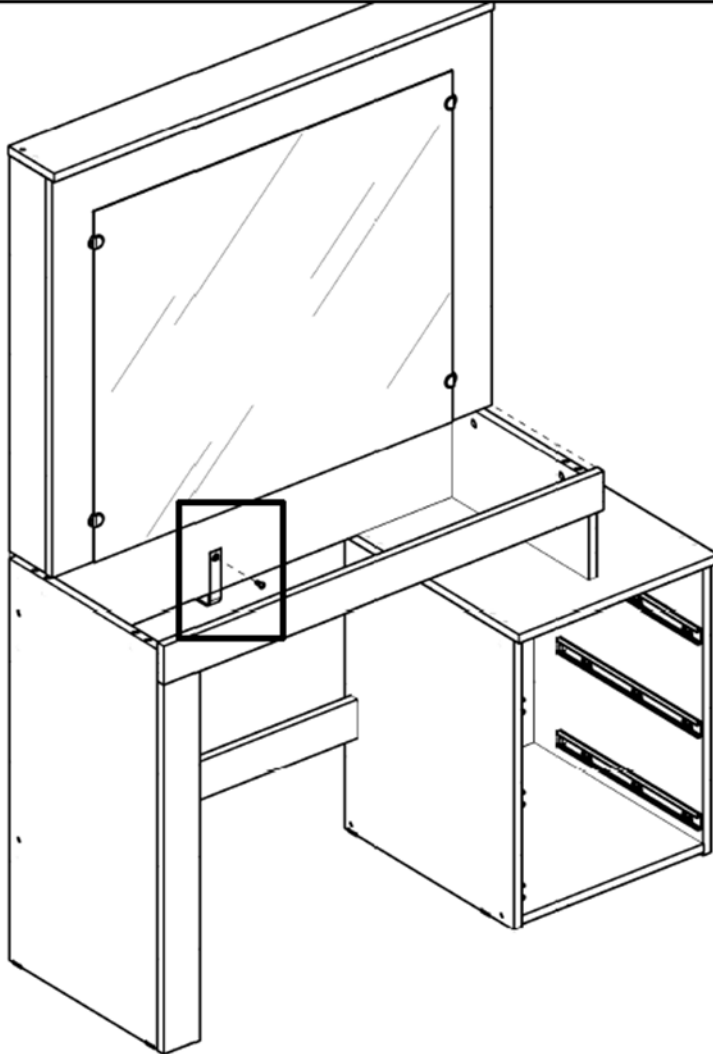

29. And finally place drawers on the furniture.

Y finalmente colocar las gavetas en el mueble.

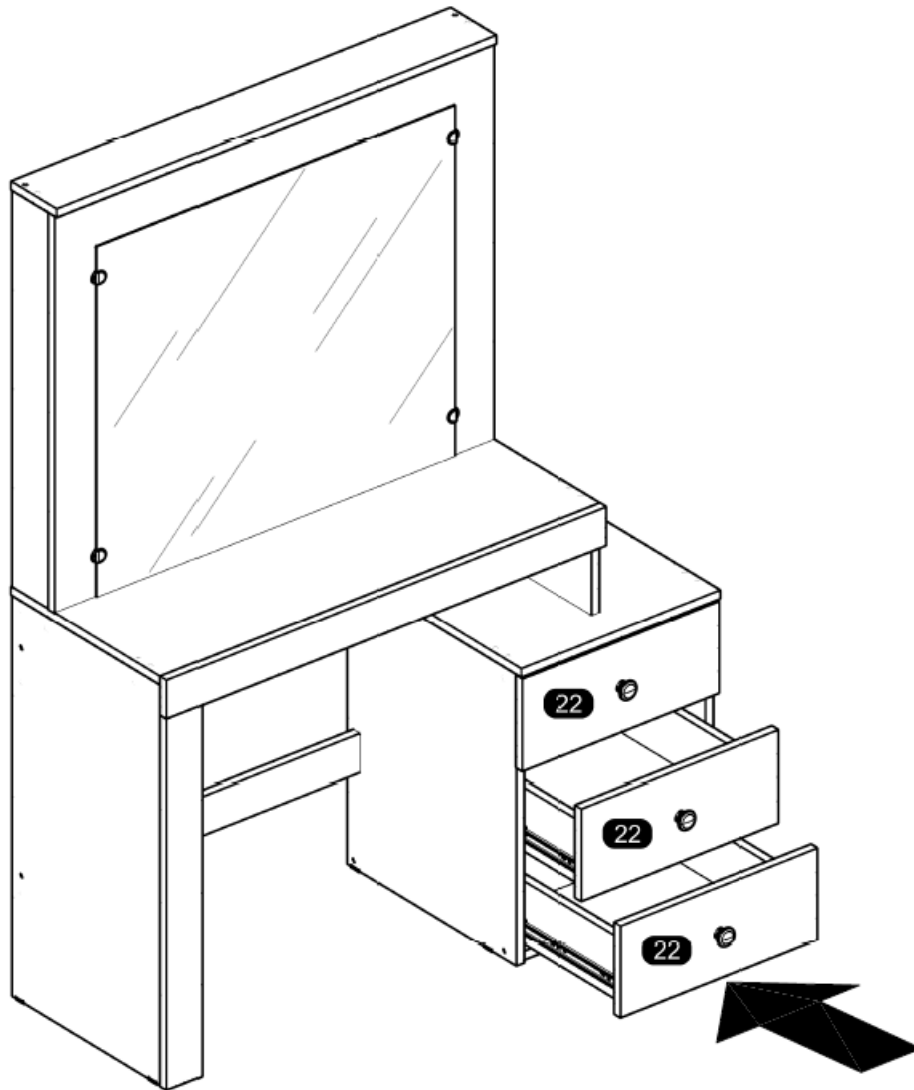



## 1607 Boahaus Dressing Table with Mirror Warranty

## 6-Months Limited Warranty

1. Boahaus, LLC provides limited warranty coverage to the original purchaser of this product for a period of six months from the date of purchase against defects in materials or workmanship of Boahaus furniture components. As used in this Warranty, "defect" means imperfections in components which substantially impair the utility of the product. This Warranty gives you specific legal rights, and you may also have other rights which vary from state to state.
2. There is no warranty coverage for defects or conditions that result from the failure to follow product assembly instructions, information or warnings, misuse or abuse, intentional damage, fire, flood, alteration or modification of the product, or use of the product in a manner inconsistent with its intended use, nor any condition resulting from incorrect or inadequate maintenance, cleaning, or care. There is also no warranty coverage for rented products or any products purchased "used" or "as is", at a distress or going-out-of business sale, or from a liquidator.
3. As the exclusive remedy under this Warranty, Boahaus will (at its sole option) repair, replace or refund the value of any defective furniture component. Boahaus may require independent confirmation of the claimed defect and proof of purchase. Replacement parts will be warranted for only the remaining period of the original Warranty. BOAHAUS SHALL HAVE NO LIABILITY for ANY INCIDENTAL OR CONSEQUENTIAL DAMAGES OF ANY KIND and all such damages are EXCLUDED FROM THIS WARRANTY, such as loss of use, disassembly, transportation, labor or damage to property on or near the product. Some states do not allow the exclusion or limitation of incidental or consequential damages, so the above limitation or exclusion may not apply to you.
4. This Warranty applies only to warranted defects that first arise and are reported to Boahaus within the warranty coverage period. The Warranty cannot be transferred to subsequent owners or users of the product, and it shall be immediately void in the event the product is resold, transferred, leased or rented to any third party or person other than the original purchaser.
5. THERE ARE NO OTHER WARRANTIES APPLICABLE TO THIS PRODUCT. Under the laws of certain states, there may be no implied warranties from Boahaus and all implied warranties, INCLUDING ANY IMPLIED WARRANTY OF MERCHANTABILITY OR FITNESS FOR A PARTICULAR PURPOSE are disclaimed where allowed by law. TO THE EXTENT ANY IMPLIED WARRANTIES ARE APPLICABLE, ANY IMPLIED WARRANTIES, INCLUDING ANY IMPLIED WARRANTY OF MERCHANTABILITY OR FITNESS FOR A PARTICULAR PURPOSE, ARE LIMITED IN DURATION TO THE DURATION OF THIS EXPRESS WARRANTY or the minimum period allowed by law, whichever is shorter. Some states do not allow limitations on how long an implied Warranty lasts, so the above limitation may not apply to you.
6. For Warranty inquiries, questions about disposition or claims, please visit our website [www.boahaus.com](http://www.boahaus.com). You can also contact Boahaus at **+1 281-809-4043** or email at [contact@boahaus.com](mailto:contact@boahaus.com). Boahaus may require Warranty claims to be submitted in writing to:

Boahaus LLC.  
1250-1252  
Ave. Franklin Delano Roosevelt,  
San Juan, PR 00926.

Please include your sales receipt or other proof of purchase and a specific description of the product defect.

## Garantía de Tocador con Espejo 1607 Boahaus

## Garantía limitada de 6 meses

1. Boahaus, LLC proporciona cobertura de garantía limitada al comprador original de este producto por un período de 6 meses a partir de la fecha de compra contra defectos en materiales o mano de obra de componentes de muebles de Boahaus. Como se especifica en esta Garantía, "defecto" significa imperfecciones en componentes que perjudican sustancialmente la utilidad del producto. Esta Garantía le otorga derechos legales específicos y también puede tener otros derechos que varían de un estado a otro.
2. No hay cobertura de garantía por defectos o condiciones que resulten del incumplimiento de las instrucciones del producto, o advertencias, uso indebido o abuso, daño intencional, incendio, inundación, alteración o modificación del producto o uso del producto de manera inconsistente con su uso previsto, o cualquier condición resultante de mantenimiento incorrecto o inadecuado, limpieza o cuidado. Tampoco hay cobertura de garantía para productos alquilados o cualquier producto comprado "usado" o "tal cual", en una venta de emergencia o de salida de la empresa, o de un liquidador.
3. Boahaus puede requerir una confirmación independiente del defecto reclamado y un comprobante de compra. Las piezas de repuesto estarán garantizadas durante el período restante de la garantía original. BOAHAUS NO TENDRÁ NINGUNA RESPONSABILIDAD POR CUALQUIER DAÑO INCIDENTAL y todos estos daños ESTÁN EXCLUIDOS DE ESTA GARANTÍA, tales como pérdida de uso, desmontaje, transporte, mano de obra o daños a la propiedad en o cerca del producto. Algunos estados no permiten la exclusión o limitación de daños incidentales o consecuentes, por lo que la limitación o exclusión anterior puede no aplicarse a usted.
4. Esta Garantía se aplica únicamente a los defectos garantizados que surgen y se informan a Boahaus dentro del período de cobertura de la garantía. La garantía no puede ser transferida a los propietarios o usuarios posteriores del producto, y será inmediatamente nula en caso de que el producto sea revendido, transferido, arrendado o alquilado a cualquier tercero o persona que no sea el comprador original.
5. NO HAY OTRAS GARANTÍAS APLICABLES A ESTE PRODUCTO. Bajo las leyes de ciertos estados, no puede haber garantías implícitas de Boahaus y todas las garantías implícitas, INCLUYENDO CUALQUIER GARANTÍA IMPLÍCITA DE COMERCIABILIDAD O ADECUACIÓN PARA UN PROPÓSITO EN PARTICULAR, están exoneradas cuando permitido por la ley. TODAS LAS GARANTÍAS IMPLÍCITAS SON APLICABLES, LAS GARANTÍAS IMPLÍCITAS, INCLUIDAS CUALQUIER GARANTÍA IMPLÍCITA DE COMERCIABILIDAD O ADECUACIÓN PARA UN PROPÓSITO PARTICULAR, ESTÁN LIMITADAS EN DURACIÓN A LA DURACIÓN DE ESTA GARANTÍA EXPRESA o el período mínimo permitido por la ley, cualquiera que sea más corto. Algunos estados no permiten limitaciones sobre la duración de una garantía implícita, por lo que es posible que la limitación anterior no se aplique a usted.
6. Para consultas sobre la garantía, preguntas sobre la disposición o reclamaciones, visite nuestro sitio web [www.boahaus.com](http://www.boahaus.com). También puede ponerse en contacto con Boahaus al **+1 281-809-4043** o por correo electrónico en [contact@boahaus.com](mailto:contact@boahaus.com) Boahaus puede requerir que los reclamos de garantía sean presentados por escrito a:

Boahaus LLC.  
1250-1252  
Ave. Franklin Delano Roosevelt,  
San Juan, PR 00926.

Incluya su recibo de compra u otra prueba de compra y una descripción específica del defecto del producto.