

BoatHaus

ASSEMBLY INSTRUCTIONS

ATTENTION!!!

Any inquiry or replacement parts
you need, contact us directly at:

contact@boahaus.com

Scan this QR Code to chat to Customer Support Team.



Or Call Us at +1 (787) 688-1254

BoaHaus

ASSEMBLY INSTRUCTIONS

INSTRUCCIONES DE ARMADO

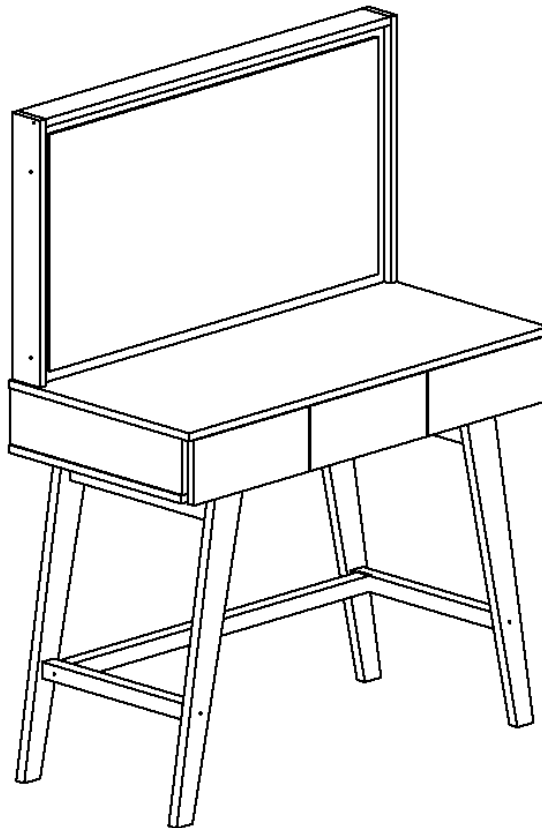

MODEL #: 1606

DRESSING TABLE WITH MIRROR

Tocador con espejo

Aprox. product weight 58.75 lbs. / 26.65 Kg. *

***Weight may vary +/- 5%.**

Lot: See package

Production date: See package

Purchase date: _____

**THIS INFORMATION BOOKLET CONTAINS IMPORTANT SAFETY INFORMATION. PLEASE READ AND KEEP FOR FUTURE REFERENCE.
ESTE FOLLETO CONTIENE INFORMACIÓN DE SEGURIDAD IMPORTANTE. POR FAVOR, LEA Y GUÁRDELO PARA REFERENCIA FUTURA.**

**Need some Help? Call +1 (787) 688-1254 or email contact@boahaus.com
¿Necesitas ayuda? Llama +1 (787) 688-1254 o envía un email contact@boahaus.com**

GENERAL SAFETY INFORMATION

1. Please read the Assembly Instructions prior to assembling this product.
2. Remove all the hardware from the box and sort by type.
3. Check to see that all the hardware and parts are present BEFORE assembling.
4. To avoid damage, assemble the product on a sturdy, level and protective surface.
5. Please wait until all steps are completed before fully tightening bolts.
6. Make sure all bolts are tightly fastened before the unit is used.
7. To move the product, you must lift it. DO NOT drag it, if you drag it can cause overturning.
8. **This product is sold with a hardware kit to be fixed on the wall. You must install this kit to prevent any accidents or damages. When properly installed, this restrain can provide protection against the unexpected tipping of the unit due to small tremors, bumps or climbing. The restrain is only a deterrent and is not a substitute for proper adult supervision. Use of tip-over restraints may only reduce, but not eliminate, the risk of tip-over**

INFORMACIÓN GENERAL DE SEGURIDAD

1. Lea las instrucciones de armado antes de ensamblar este producto.
2. Extraiga todo el hardware de la caja y ordene por tipo.
3. Verifique que todo el hardware y las piezas están presentes ANTES de ensamblar.
4. Para evitar daños, ensamble el producto sobre una superficie resistente, nivelada y con protección.
5. Espere hasta que todos los pasos se hayan completado antes de apretar completamente los tornillos y accesorios.
6. Asegúrese de que todos los tornillos y accesorios estén bien apretados antes de usar la unidad.
7. Para mover el producto debe levantarlo. NO lo arrastre, si lo arrastra puede causar volcamiento.
8. **Este producto se vende con un kit de accesorios para ser fijado en la pared. Debe instalar este kit para evitar accidentes o daños. Cuando se instala correctamente, esta restricción puede proporcionar protección contra la inclinación inesperada de la unidad debido a temblores pequeños, golpes o al treparse. La restricción es solo un elemento disuasivo y no es un sustituto de la supervisión adecuada de un adulto. El uso de restricciones de vuelco solo puede reducir, pero no eliminar, el riesgo de volcarse.**

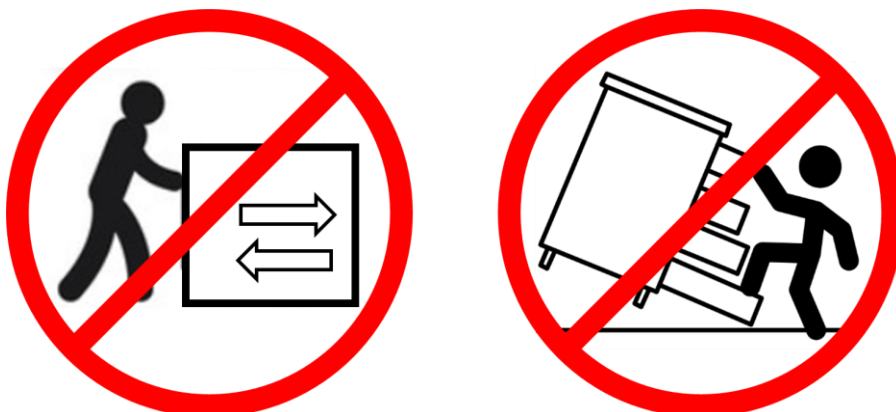

You can see the assembly video scanning this QR code.



Or entering the following link:

<https://boahaus.com/products/boahaus-urban-dressing-table>

General Dimensions / Dimensiones Generales

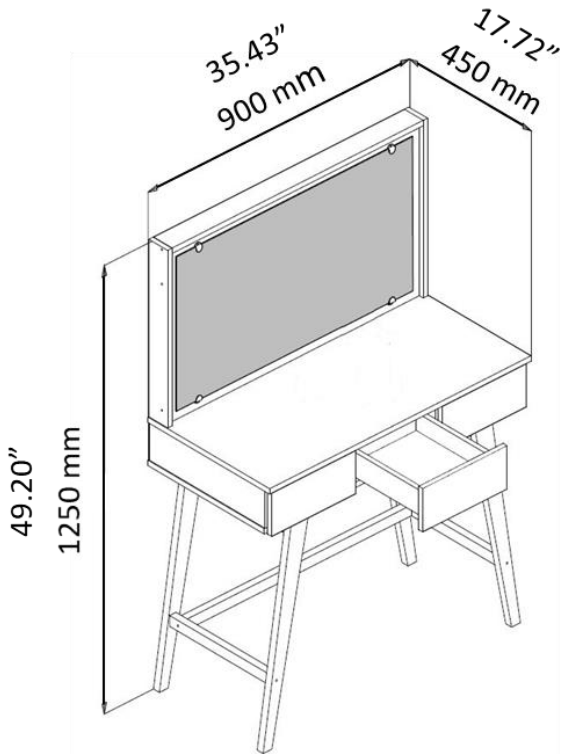

Maximum weight supported / Peso máximo soportado

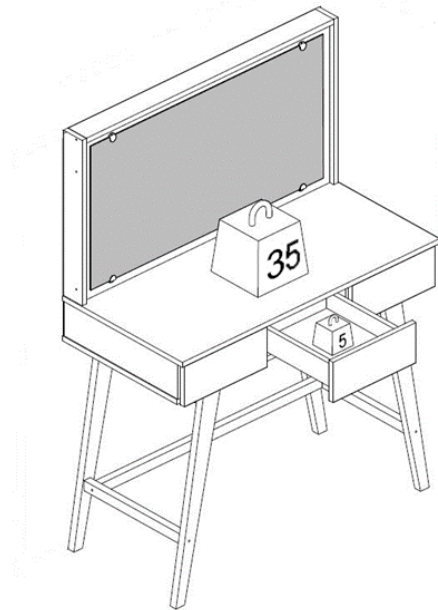

Weight in pounds. / Peso en libras.

Note: weight must be evenly distributed.
Nota: el peso debe estar distribuido uniformemente.

You will need / usted necesitará:

Tools not included / herramientas no incluidas



1 Person
1 Persona

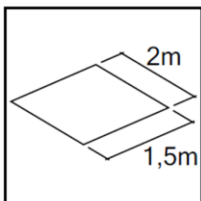

Recommended space for assembly
Espacio recomendado para el armado

Note: Place a carpet or blanket in the assembly area to avoid damage to the parts during the process.
Nota: Colocar una alfombra o manta en el area de armado para evitar daños en las piezas durante el proceso.

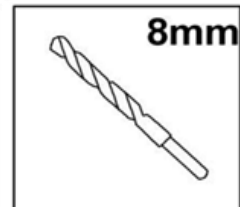
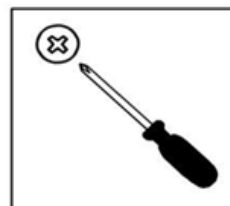

The drill will be used ONLY to fix the furniture to the wall.
El taladro será usado SOLO para fijar el mueble a la pared.

PARTS IDENTIFICATION / IDENTIFICACION DE PARTES



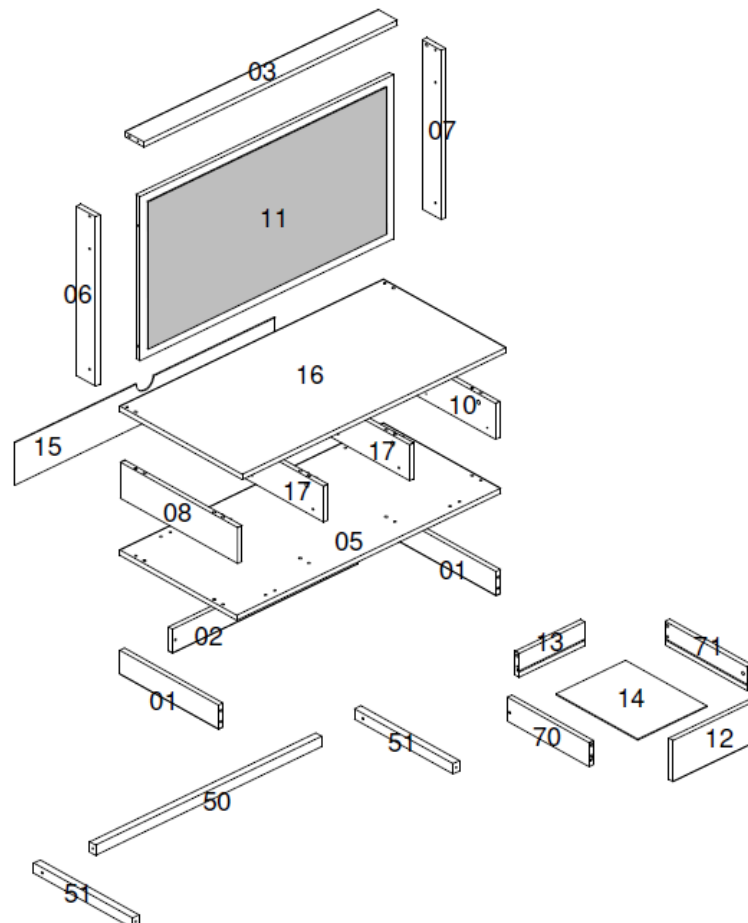





Nº	DESCRIPTION - DESCRIPCIÓN	QTY.
1	Lateral foot tray / Travesaño lateral del pie	2
2	Rear foot tray / Travesaño posterior del pie	1
3	Top tray / Travesaño superior	1
5	Bottom base / Base inferior	1
6	Left tray / Travesaño izquierdo	1
7	Right tray / Travesaño derecho	1
8	Left side / Lateral izquierdo	1
10	Right side / Lateral derecho	1
11	Pannel / Panel	1
12	Front of drawer / Frontal de cajón	3
13	Rear of drawer / Posterior de cajón	3
14	Bottom of drawer / Fondo de cajón	3
15	Backboard / Fondo trasero	1
16	Top base / Base superior	1
17	Division / División	2
50	Rear inferior foot tray / Travesaño inferior trasero del pie	1
51	Lateral inferior foot tray / Travesaño inferior lateral del pie	2
70	Left side of drawer / Lateral izquierdo de cajón	3
71	Right side of drawer / Lateral derecho de cajón	3



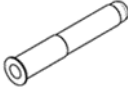
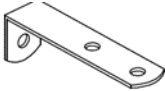



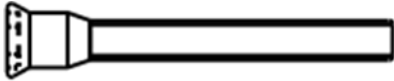

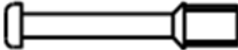
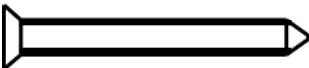



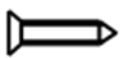

IDENTIFICATION OF ACCESSORIES / IDENTIFICACION DE ACCESORIOS

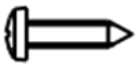
Note: the separation of the accessories before starting the assembly will facilitate it.

Nota: la separación de los accesorios antes de empezar el armado facilitará el mismo.

CODE		DESCRIPTION	QTY
A		Flanged head screw / Tornillo cabeza flangeada (5 x 60 mm)	1
A1		Glue / Pegamento	1
A3		Trapeze / Trapecio	6
B3		Bushing / Tapón	1
B7		Metallic bracket / Soporte de metal	1
E		Wooden dowel / Pin (8 x 30 mm)	34
E4		Mirror support / Soporte espejo	4
F		Wooden dowel / Pin (8 x 50 mm)	2
F1		Wooden dowel / Pin (6 x 30 mm)	8
G		Structural screw / Tornillo estructural (5 x 50 mm)	6
H		Allen key / Llave allen	1
I		Structural screw cover / Tapa de tornillo estructural	6
J		Simple minifix screw / Tornillo minifix simple	8
K6		Flat head screw / Tornillo cabeza plana (4,5 x 40 mm)	8

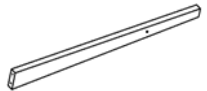
L		Drum lock / Tambor minifix	8
M1		Flat head screw / Tornillo cabeza plana (3,5 x 25 mm)	2
N		Nail / Clavo	16
O		Flat head screw / Tornillo cabeza plana (4,5 x 45 mm)	22
P		Pan head screw / Tornillo cabeza pan (4,5 x 25 mm)	6
P5		Flat head screw / Tornillo cabeza plana (3,5 x 14 mm)	16
R		Flat head screw / Tornillo cabeza plana (6 x 8 mm)	8
S		Pan head screw / Tornillo cabeza redondeada (3,5 x 14 mm)	6
XA		Metallic left slide 300mm / Corredera lateral izquierda 300mm	3
XB		Metallic right slide 300 mm / Corredera lateral derecha 300mm	3
XC		Left drawer slide 300mm / Corredera cajón izquierda 300mm	3
XD		Right drawer slide 300 mm/ Corredera cajón derecha 300 mm	3
Y7A		Angular foot 1 / Pie angular 1 (620 mm)	2
Y7B		Angular foot 2 / Pie angular 2 (620 mm)	2

PRE-ASSEMBLY / PRE- ARMADO

1. Fix *mirror support* (E4) to *panel* (11)
Fijar *soporte de espejo* (E4) a *panel* (11).

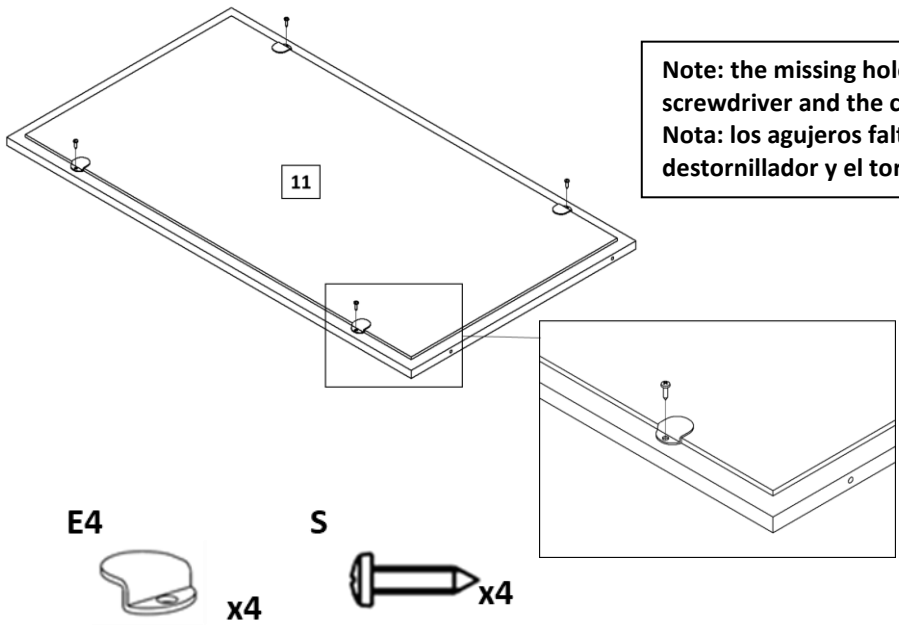

Note: the missing holes must be made with the screwdriver and the corresponding screw.
Nota: los agujeros faltantes deben hacerse con el destornillador y el tornillo correspondiente.

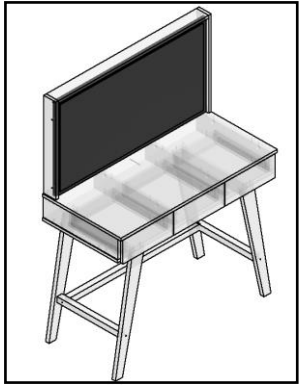

2. Fix *simple minifix screw* (J) and *metallic bracket* (B7) to *top* (16).
Fijar *tornillo minifix simple* (J) y *soporte metálico* (B7) a *tapa* (16).

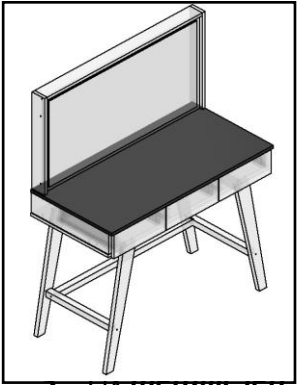
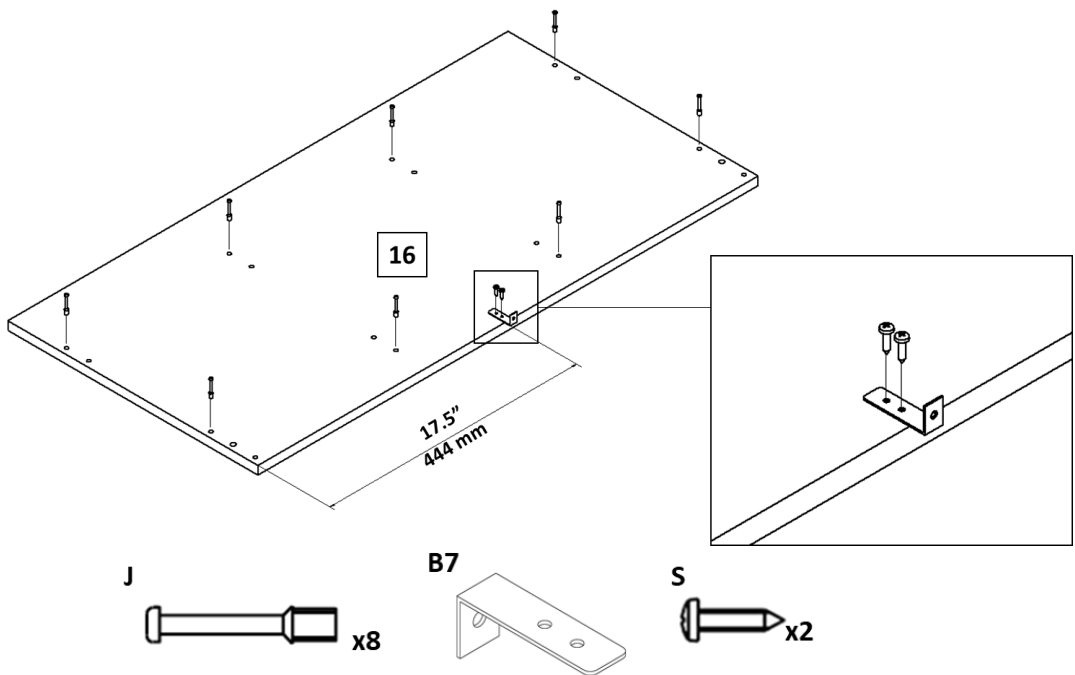

Note: the missing holes must be made with the screwdriver and the corresponding screw.
Nota: los agujeros faltantes deben hacerse con el destornillador y el tornillo correspondiente.

slide (XA) and *wooden dowel* (E) to *left side* (8).

Fijar *corredera metálica izquierda* (XA) y *pin* (E) a *lateral izquierdo* (8).

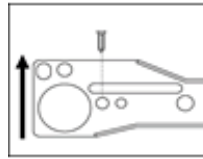
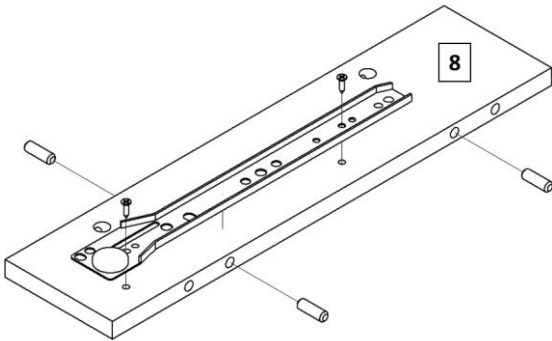

Note: the two upper holes have to be facing up.
Nota: los dos agujeros superiores deben estar hacia arriba.

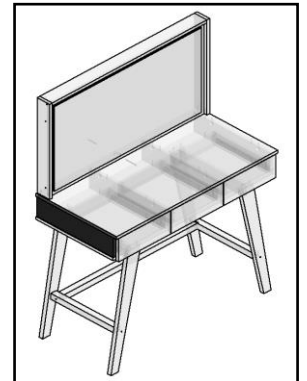

4. Fix *metallic right slide* (XB) and *wooden dowel* (E) to *right side* (10).

Fijar *corredera metálica derecha* (XB) y *pin* (E) a *lateral derecho* (10).

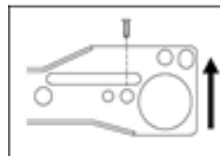
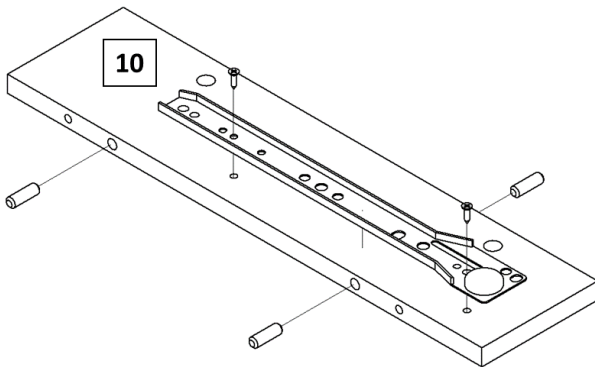

Note: the two upper holes have to be facing up.
Nota: los dos agujeros superiores deben estar hacia arriba.

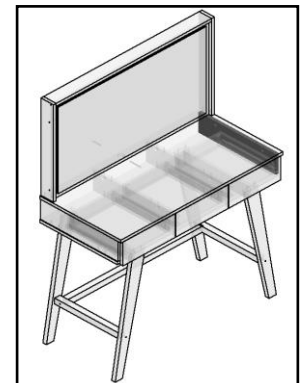
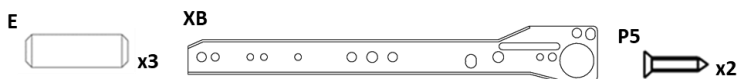

5. Fix **metallic left slide** (XA), **metallic right slide** (XB) and **wooden dowel** (E) to **division** (17) x2.
 Fijar **corredera metálica izquierda** (XA), **corredera metálica derecha** (XB) y **pin** (E) a **división** (17) x2.

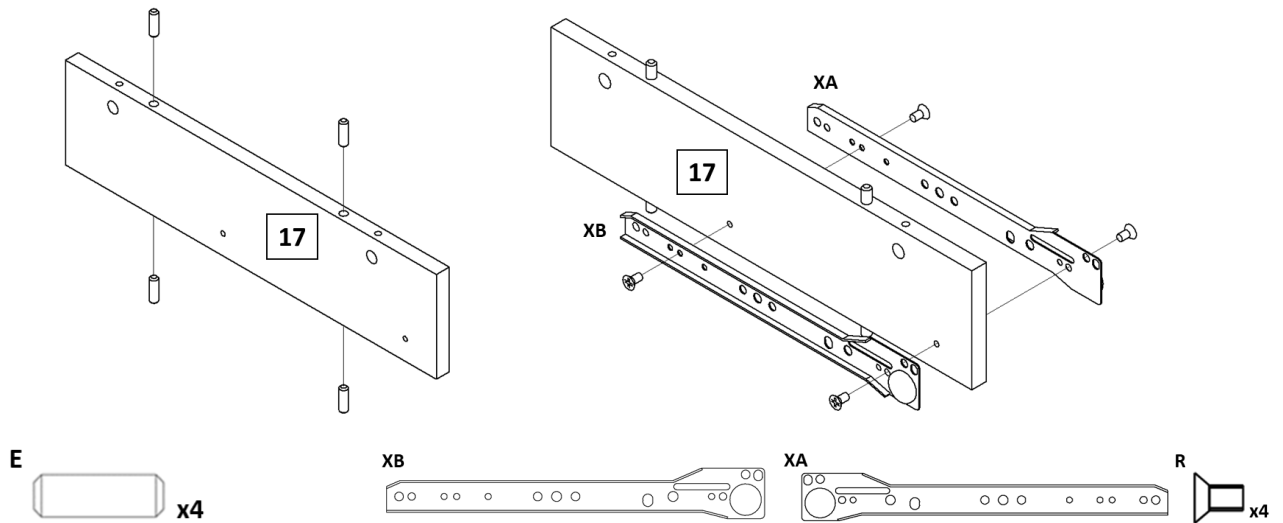

Note: the two upper holes have to be facing up.
Nota: los dos agujeros superiores deben estar hacia arriba.

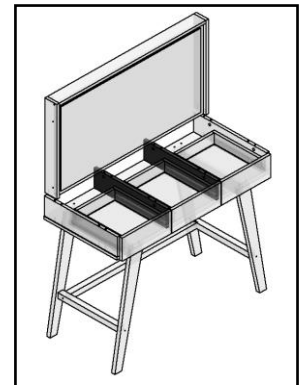
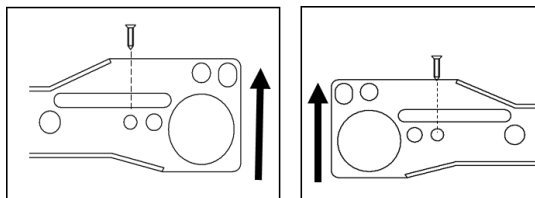

6. Fix **wooden dowel** (E) to **top tray** (3)
 Fijar **pin** (E) a **travesaño superior** (3).

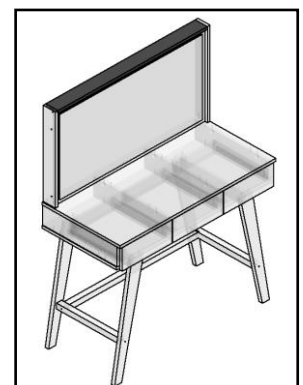
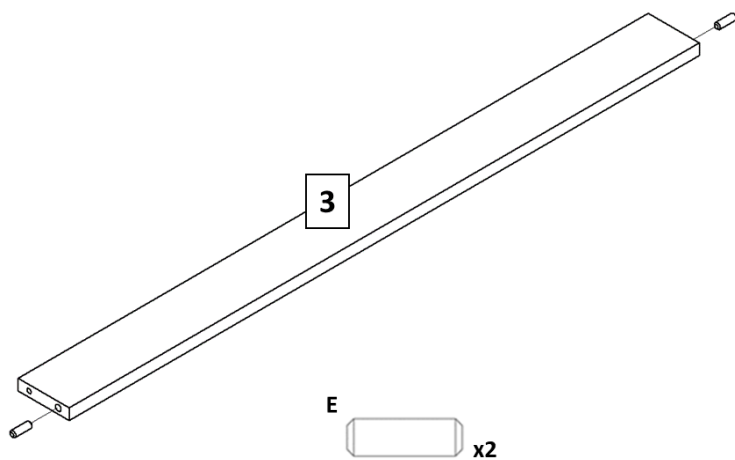

7. Fix **wooden dowel** (F) to **left tray** (6) and **right tray** (7).
 Fijar **pin** (F) a **travesaño izquierdo** (6) y **travesaño derecho** (7).

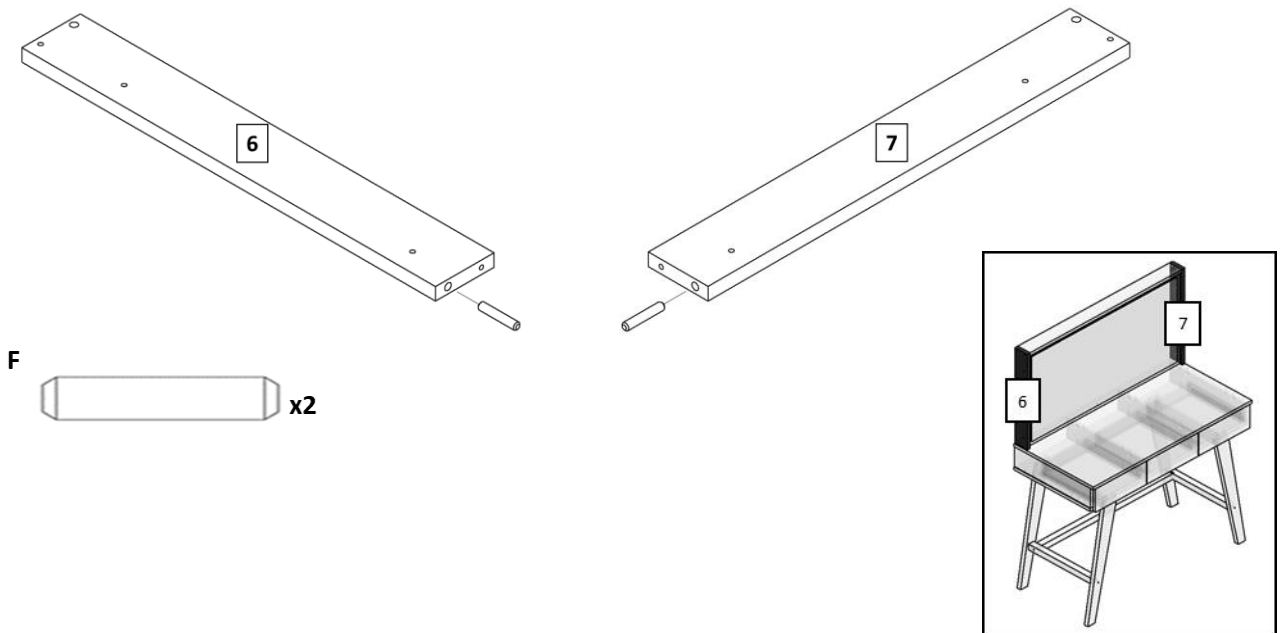

8. Fix **wooden dowel** (E) with **glue** (A1) to **left side of drawer** (70) x3 and **right side of drawer** (71) x3.
 Fijar **pin** (E) con **pegamento** (A1) a **lateral izquierdo de cajón** (70) x3 y **lateral derecho de cajón** (71) x3.

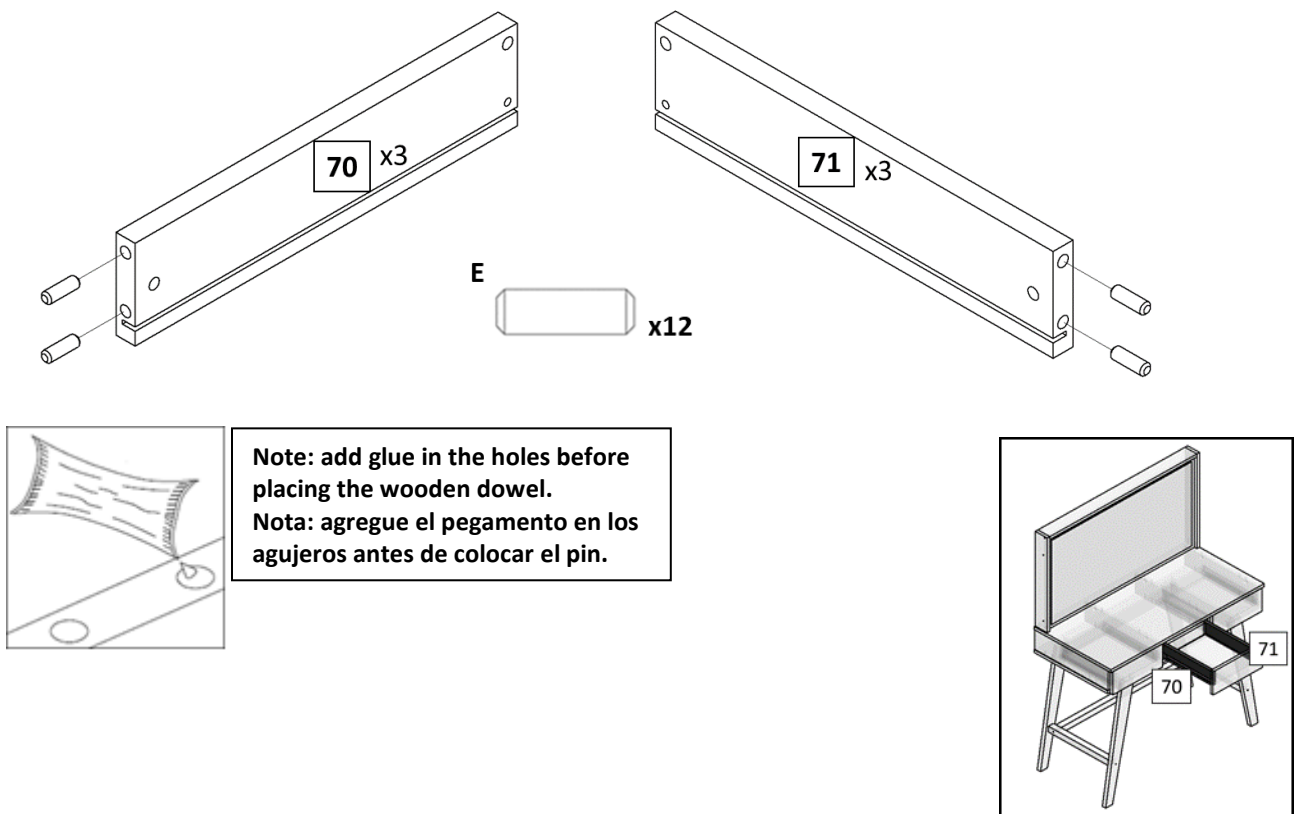

9. Fix **wooden dowel** (E) to **rear of drawer** (13) x3.
 Fijar **pin** (E) a **posterior de cajón** (13) x3.

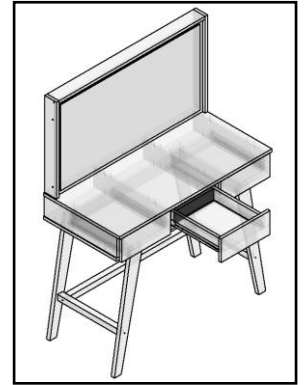
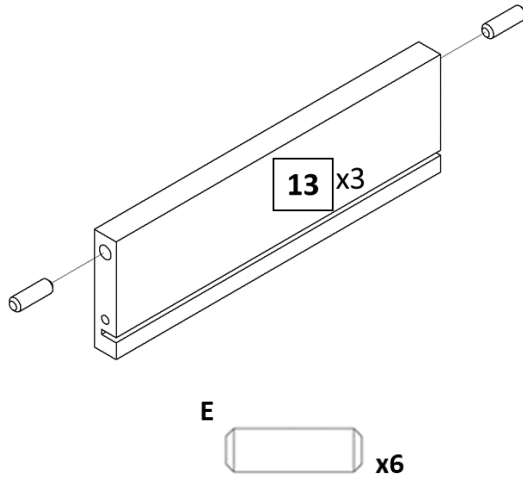

10. Fix **wooden dowel** (F1) with **glue** (A1) to **lateral foot tray** (1) x2.
 Fijar **pin** (F1) con **pegamento** (A1) a **travesaño lateral del pie** (1) x2.

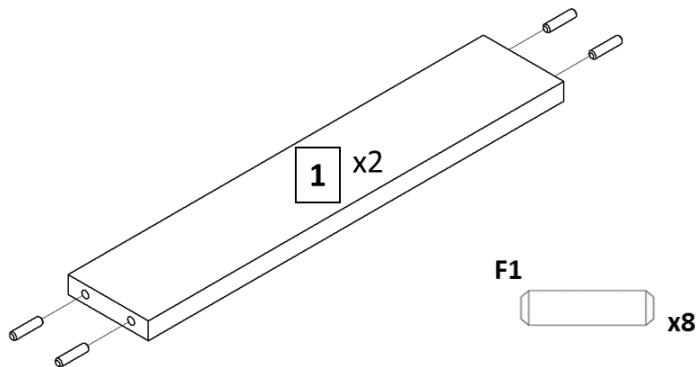

Note: add glue in the holes before placing the wooden dowel.
Nota: agregue el pegamento en los agujeros antes de colocar el pin.

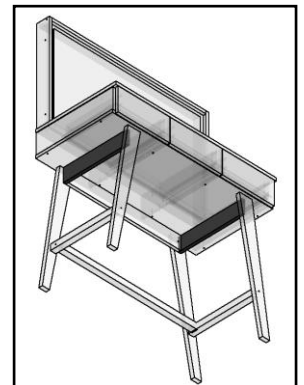
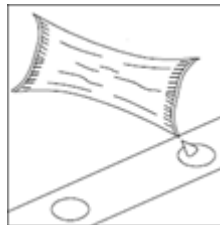

ASSEMBLY / ARMADO

11. Fix **left tray** (6), **right tray** (7) and **top tray** (3) to **panel** (11).
 Fijar **travesaño izquierdo** (6), **travesaño derecho** (7) y **travesaño superior** (3) a **panel** (11).

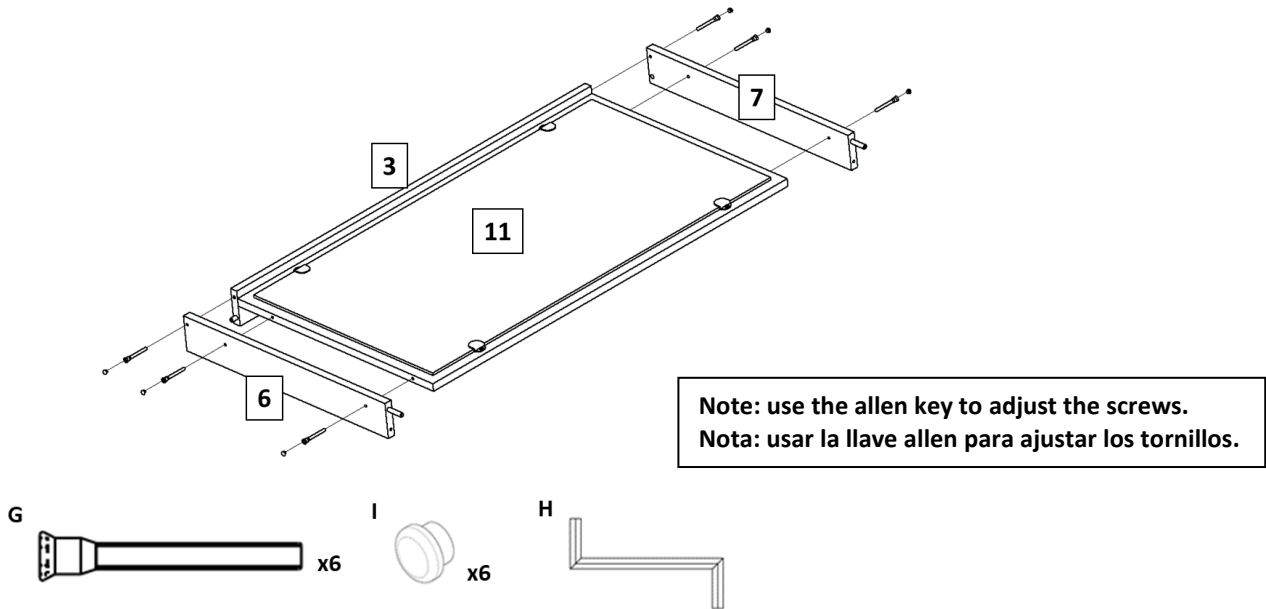

12. Fix **top** (16) to previous assembly.
 Fijar **tapa** (16) al ensamble previo.

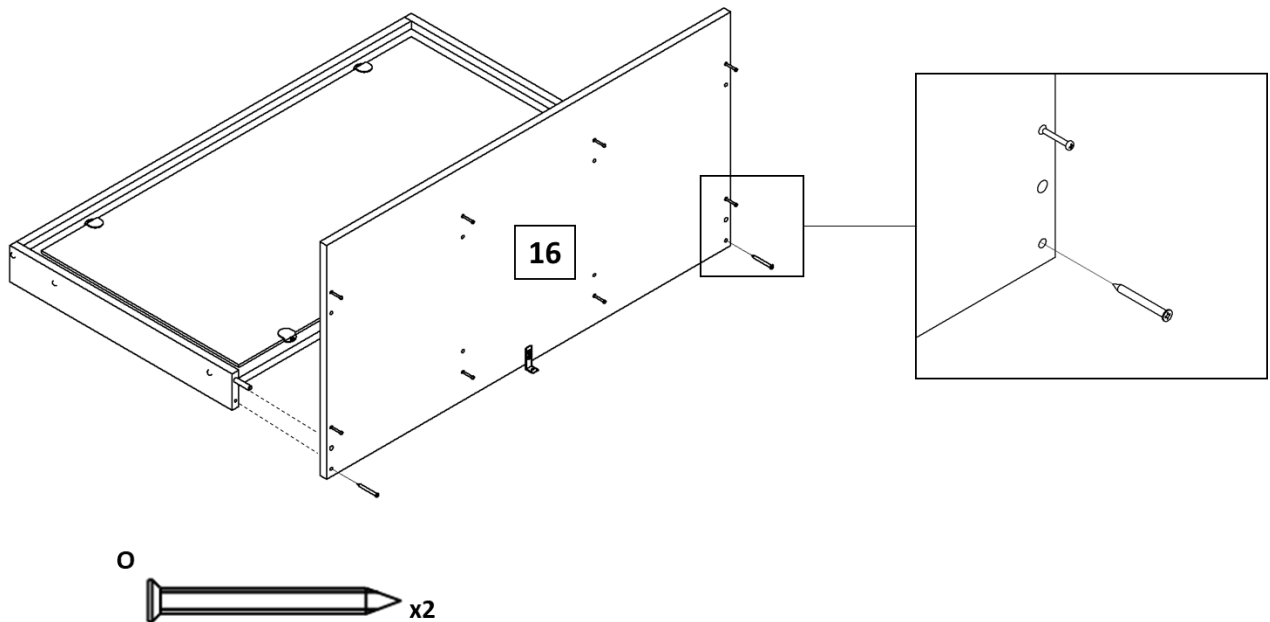

13. Fix **left side** (8), **division** (9) x2 and **right side** (10) to **top** (4).
 Fijar **lateral izquierdo** (8), **división** (9) x2 y **lateral derecho** (10) a **tapa** (4).

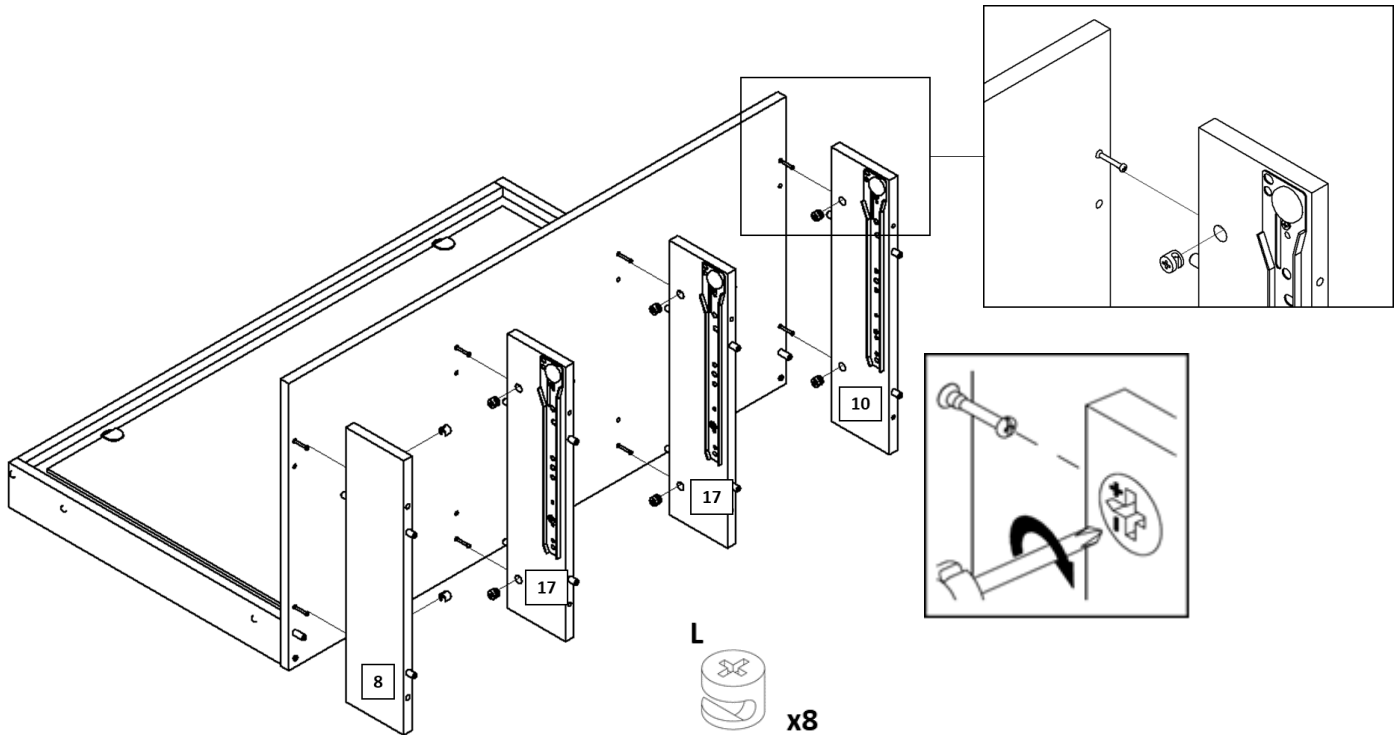

14. Fix **lateral tray** (1) to **angular foot 1** (Y7A) and **angular foot 2** (Y7B) x2.
 Fijar **travesaño lateral** (1) a **pie angular 1** (Y7A) y **pie angular** (Y7B) x2.

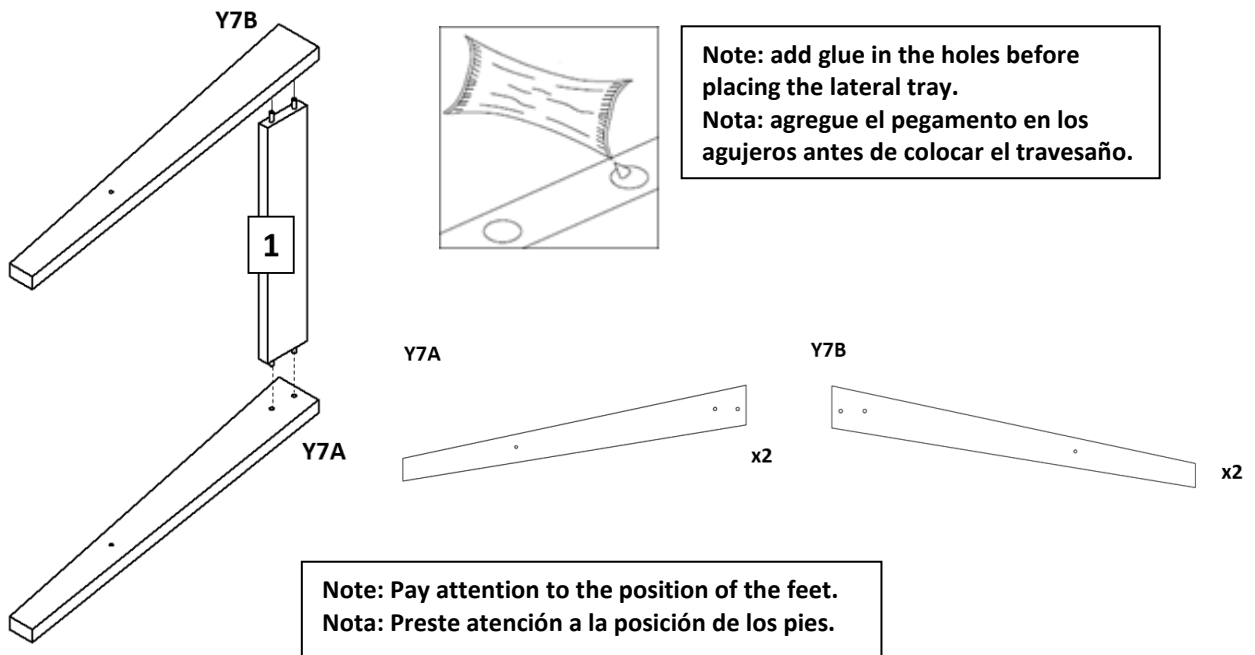

15. Fix **bottom base** (5) to previous assembly.
 Fijar **base inferior** (5) a ensamble previo.

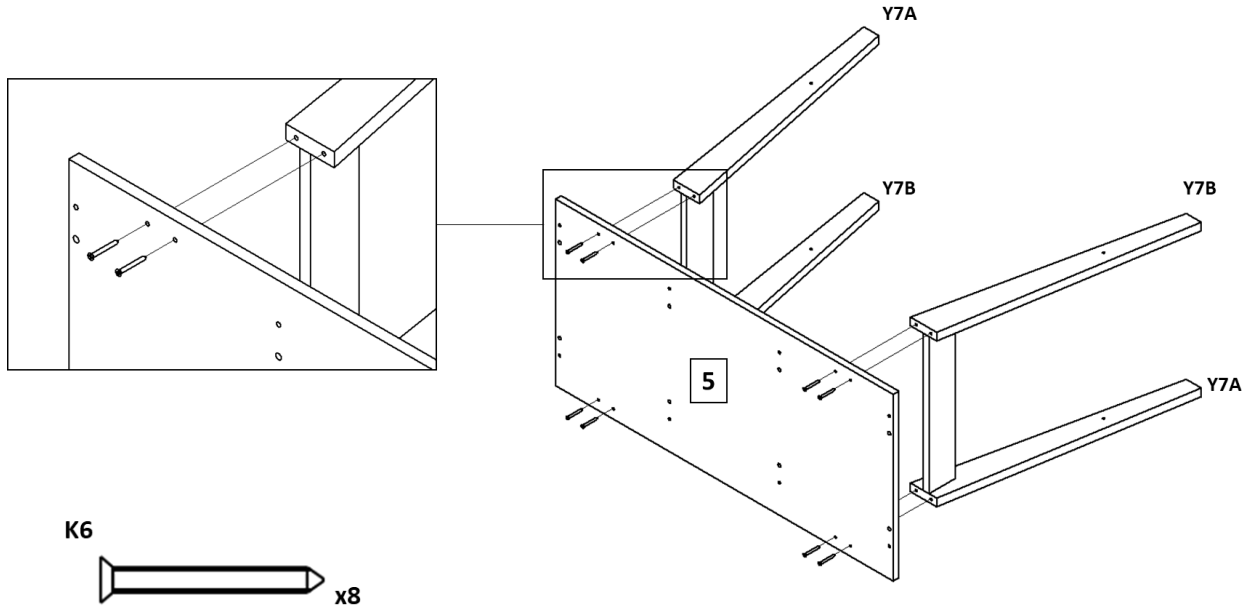

Note: Pay attention to the position of the feet.
Nota: Preste atención a la posición de los pies.

16. Fix both previous assemblies.
 Fijar ambos ensambles previos.

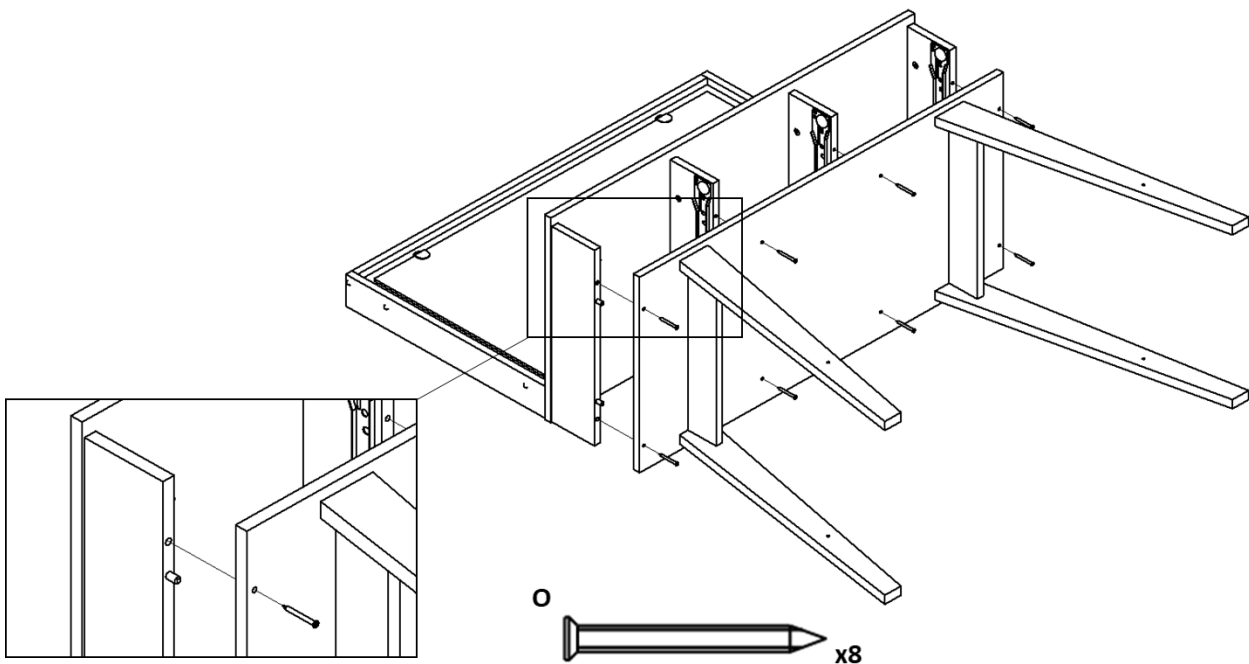

17. Fix *rear foot tray* (2).

Fijar *travesaño posterior del pie* (2).

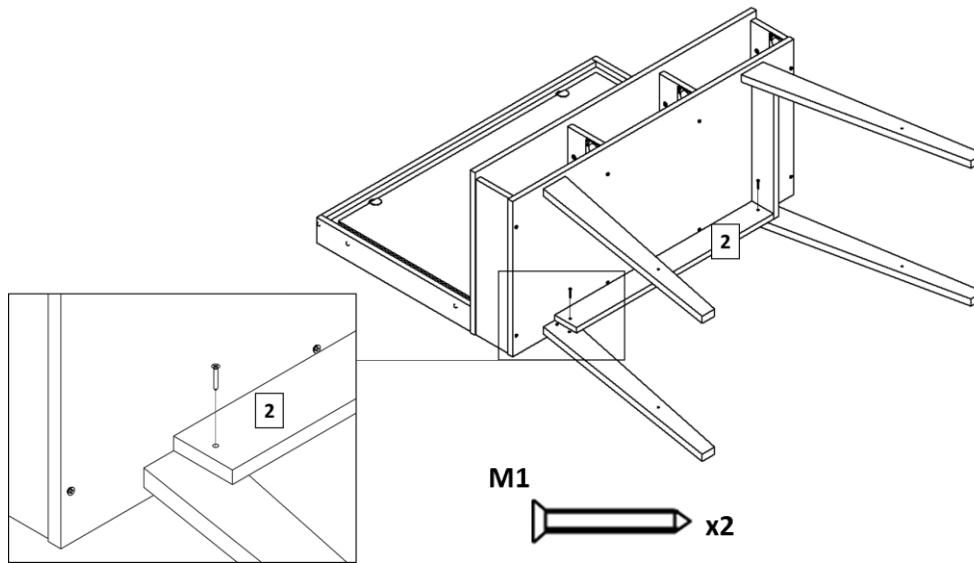

Note: the missing holes must be made with the screwdriver and the corresponding screw.
 Nota: los agujeros faltantes deben hacerse con el destornillador y el tornillo correspondiente.

18. Incorporate the furniture and fix *lateral inferior foot tray* (51) x2 and *rear inferior foot tray* (50).

Then *fix backboard* (15)

Incorporar el mueble y fijar *travesaño lateral posterior del pie* (51) x2 y *travesaño trasero inferior del pie* (50). Luego fije *fondo trasero* (15).

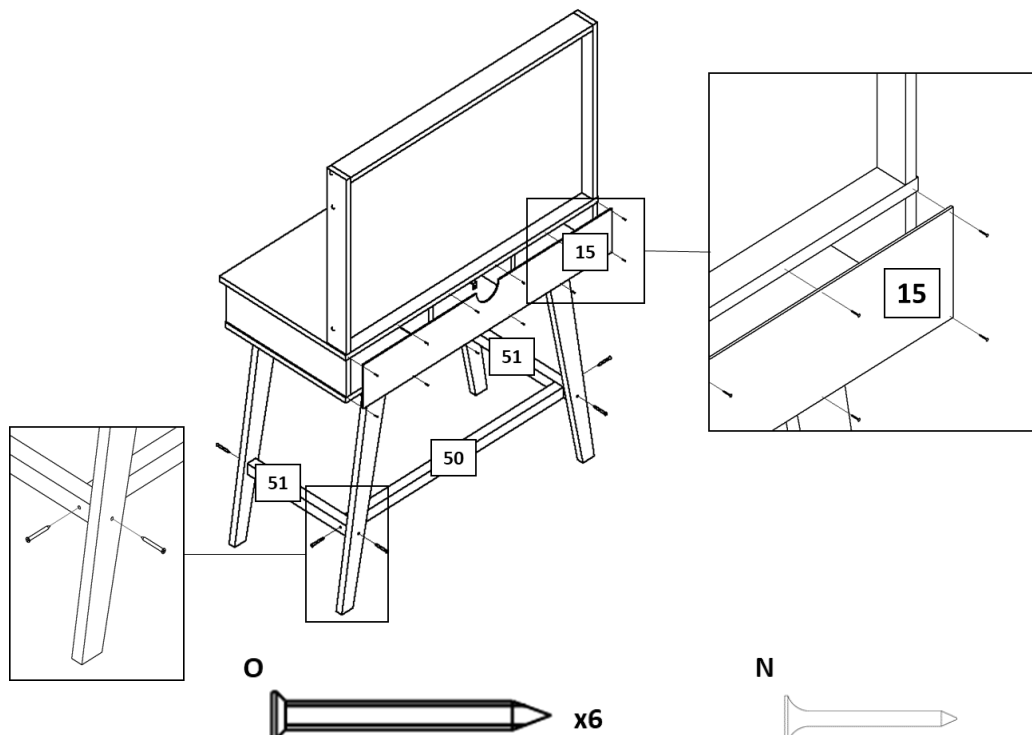

19. Assemble drawer x3.
Ensamblar cajones x3.

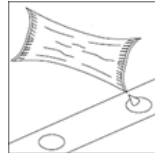
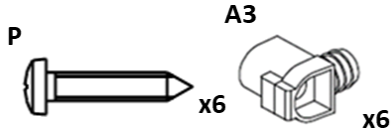
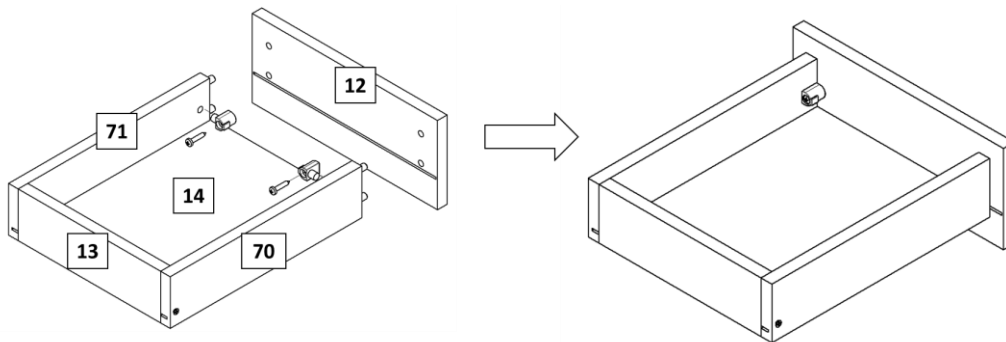
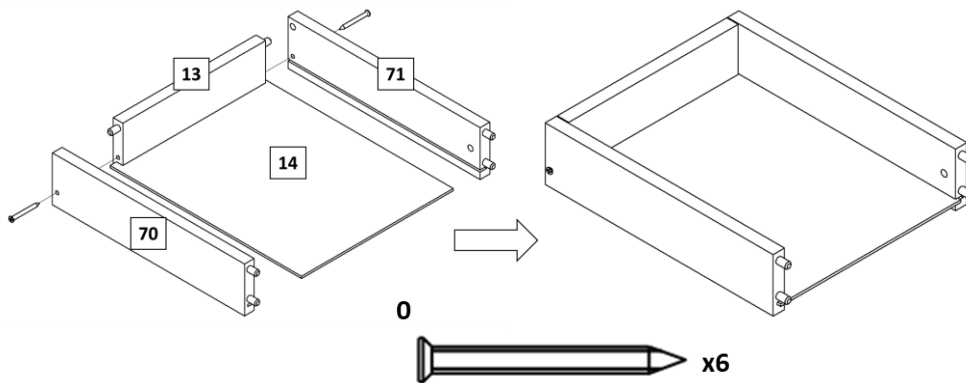

Note: add glue in the holes before placing the front of drawer
Nota: agregue el pegamento en los agujeros antes de colocar el frontal del cajón

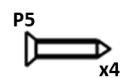
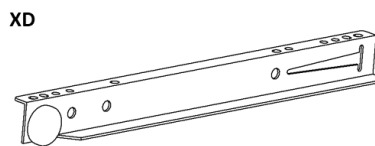
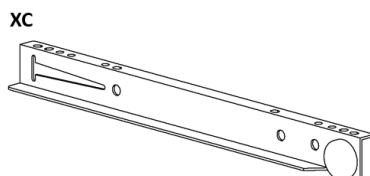
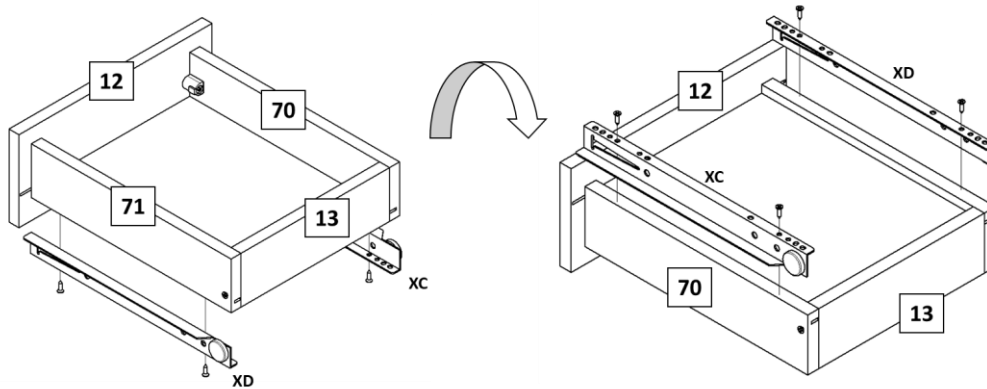

Note: the missing holes must be made with the screwdriver and the corresponding screw.
Nota: los agujeros faltantes deben hacerse con el destornillador y el tornillo correspondiente.

20. Fix furniture to the wall.
Fijar el mueble a la pared.

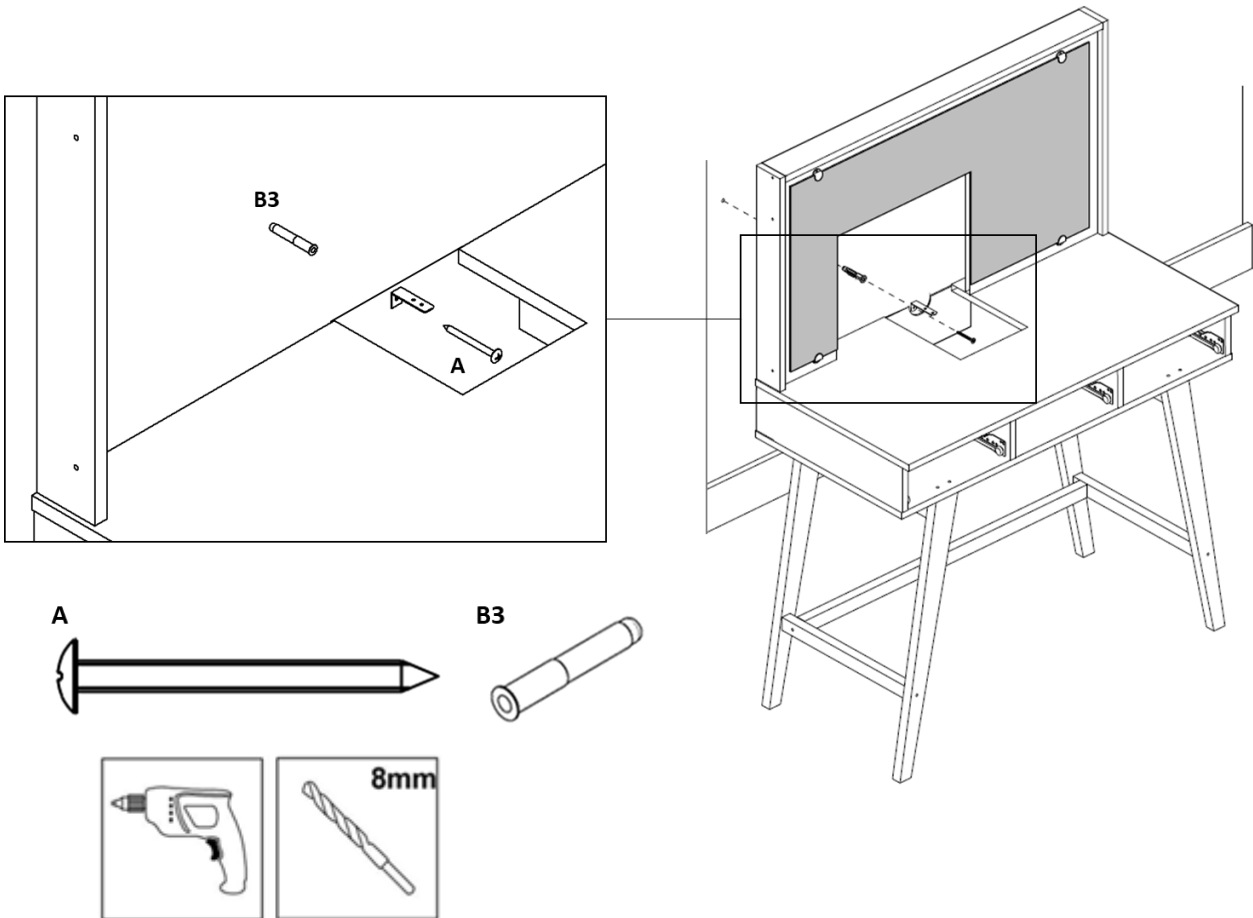

WARNING.

For security measures it is recommended to fix the furniture to the wall to avoid overturning of it, if this happens it can cause serious or fatal injuries.

ATENCIÓN.

Por medidas de seguridad se recomienda fijar el mueble a la pared para evitar volcamiento del mismo, si esto llegase a ocurrir puede causar lesiones graves o fatales.

- 21.** And finally place drawers.
Y finalmente coloque los cajones.

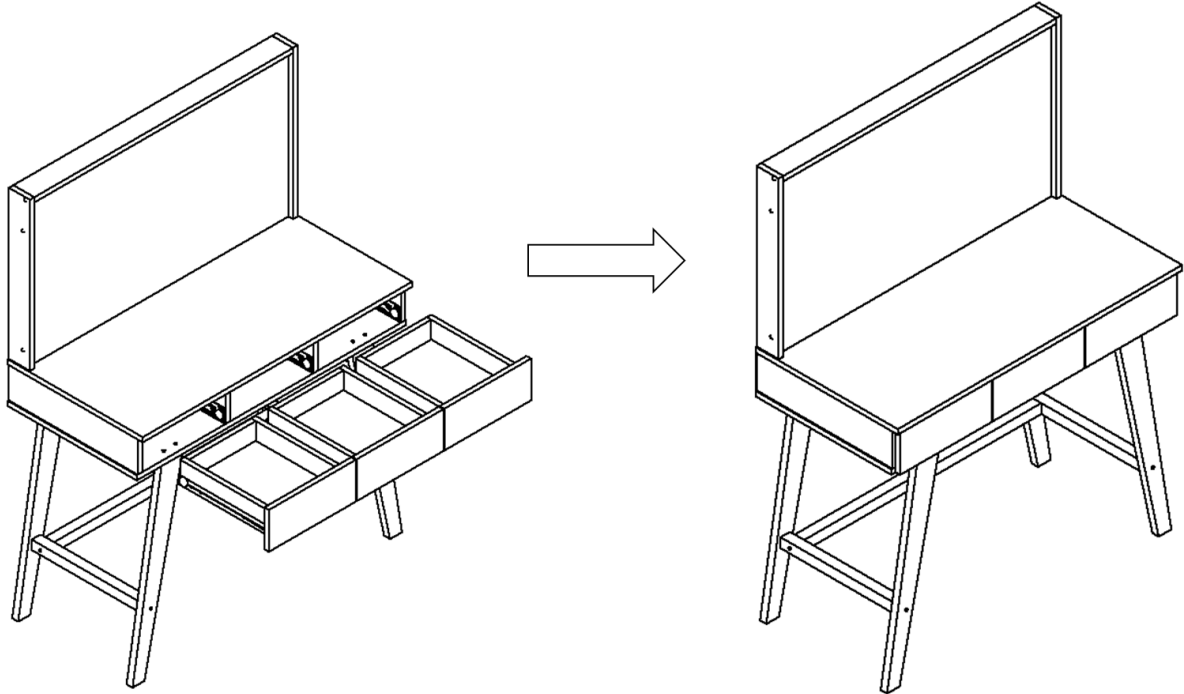

***Congratulations, you have assembled your Dressing Table with Mirror!!!
¡¡¡Felicitaciones, has armado tu Tocador con Espejo!!!***

1606 Boahaus Dressing Table with Mirror Warranty**6-Months Limited Warranty**

1. Boahaus, LLC provides limited warranty coverage to the original purchaser of this product for a period of six months from the date of purchase against defects in materials or workmanship of Boahaus furniture components. As used in this Warranty, "defect" means imperfections in components which substantially impair the utility of the product. This Warranty gives you specific legal rights, and you may also have other rights which vary from state to state.
2. There is no warranty coverage for defects or conditions that result from the failure to follow product assembly instructions, information or warnings, misuse or abuse, intentional damage, fire, flood, alteration or modification of the product, or use of the product in a manner inconsistent with its intended use, nor any condition resulting from incorrect or inadequate maintenance, cleaning, or care. There is also no warranty coverage for rented products or any products purchased "used" or "as is", at a distress or going-out-of business sale, or from a liquidator.
3. As the exclusive remedy under this Warranty, Boahaus will (at its sole option) repair, replace or refund the value of any defective furniture component. Boahaus may require independent confirmation of the claimed defect and proof of purchase. Replacement parts will be warranted for only the remaining period of the original Warranty. BOAHAUS SHALL HAVE NO LIABILITY for ANY INCIDENTAL OR CONSEQUENTIAL DAMAGES OF ANY KIND and all such damages are EXCLUDED FROM THIS WARRANTY, such as loss of use, disassembly, transportation, labor or damage to property on or near the product. Some states do not allow the exclusion or limitation of incidental or consequential damages, so the above limitation or exclusion may not apply to you.
4. This Warranty applies only to warranted defects that first arise and are reported to Boahaus within the warranty coverage period. The Warranty cannot be transferred to subsequent owners or users of the product, and it shall be immediately void in the event the product is resold, transferred, leased or rented to any third party or person other than the original purchaser.
5. THERE ARE NO OTHER WARRANTIES APPLICABLE TO THIS PRODUCT. Under the laws of certain states, there may be no implied warranties from Boahaus and all implied warranties, INCLUDING ANY IMPLIED WARRANTY OF MERCHANTABILITY OR FITNESS FOR A PARTICULAR PURPOSE are disclaimed where allowed by law. TO THE EXTENT ANY IMPLIED WARRANTIES ARE APPLICABLE, ANY IMPLIED WARRANTIES, INCLUDING ANY IMPLIED WARRANTY OF MERCHANTABILITY OR FITNESS FOR A PARTICULAR PURPOSE, ARE LIMITED IN DURATION TO THE DURATION OF THIS EXPRESS WARRANTY or the minimum period allowed by law, whichever is shorter. Some states do not allow limitations on how long an implied Warranty lasts, so the above limitation may not apply to you.
6. For Warranty inquiries, questions about disposition or claims, please visit our website www.boahaus.com. You can also contact Boahaus at +1 **(787) 688-1254** or email at administracion@boahaus.com. Boahaus may require Warranty claims to be submitted in writing to:

Boahaus LLC.
1250-1252
Ave. Franklin Delano Roosevelt,
San Juan, PR 00926.

Please include your sales receipt or other proof of purchase and a specific description of the product defect.

Garantía de Tocador con Espejo 1606 Boahaus**Garantía limitada de 6 meses**

1. Boahaus, LLC proporciona cobertura de garantía limitada al comprador original de este producto por un período de 6 meses a partir de la fecha de compra contra defectos en materiales o mano de obra de componentes de muebles de Boahaus. Como se especifica en esta Garantía, "defecto" significa imperfecciones en componentes que perjudican sustancialmente la utilidad del producto. Esta Garantía le otorga derechos legales específicos y también puede tener otros derechos que varían de un estado a otro.
2. No hay cobertura de garantía por defectos o condiciones que resulten del incumplimiento de las instrucciones del producto, o advertencias, uso indebido o abuso, daño intencional, incendio, inundación, alteración o modificación del producto o uso del producto de manera inconsistente con su uso previsto, o cualquier condición resultante de mantenimiento incorrecto o inadecuado, limpieza o cuidado. Tampoco hay cobertura de garantía para productos alquilados o cualquier producto comprado "usado" o "tal cual", en una venta de emergencia o de salida de la empresa, o de un liquidador.
3. Boahaus puede requerir una confirmación independiente del defecto reclamado y un comprobante de compra. Las piezas de repuesto estarán garantizadas durante el período restante de la garantía original. BOAHAUS NO TENDRÁ NINGUNA RESPONSABILIDAD POR CUALQUIER DAÑO INCIDENTAL y todos estos daños ESTÁN EXCLUIDOS DE ESTA GARANTÍA, tales como pérdida de uso, desmontaje, transporte, mano de obra o daños a la propiedad en o cerca del producto. Algunos estados no permiten la exclusión o limitación de daños incidentales o consecuentes, por lo que la limitación o exclusión anterior puede no aplicarse a usted.
4. Esta Garantía se aplica únicamente a los defectos garantizados que surgen y se informan a Boahaus dentro del período de cobertura de la garantía. La garantía no puede ser transferida a los propietarios o usuarios posteriores del producto, y será inmediatamente nula en caso de que el producto sea revendido, transferido, arrendado o alquilado a cualquier tercero o persona que no sea el comprador original.
5. NO HAY OTRAS GARANTÍAS APLICABLES A ESTE PRODUCTO. Bajo las leyes de ciertos estados, no puede haber garantías implícitas de Boahaus y todas las garantías implícitas, INCLUYENDO CUALQUIER GARANTÍA IMPLÍCITA DE COMERCIABILIDAD O ADECUACIÓN PARA UN PROPÓSITO EN PARTICULAR, están exoneradas cuando permitido por la ley. TODAS LAS GARANTÍAS IMPLÍCITAS SON APLICABLES, LAS GARANTÍAS IMPLÍCITAS, INCLUIDAS CUALQUIER GARANTÍA IMPLÍCITA DE COMERCIABILIDAD O ADECUACIÓN PARA UN PROPÓSITO PARTICULAR, ESTÁN LIMITADAS EN DURACIÓN A LA DURACIÓN DE ESTA GARANTÍA EXPRESA o el período mínimo permitido por la ley, cualquiera que sea más corto. Algunos estados no permiten limitaciones sobre la duración de una garantía implícita, por lo que es posible que la limitación anterior no se aplique a usted.
6. Para consultas sobre la garantía, preguntas sobre la disposición o reclamaciones, visite nuestro sitio web www.boahaus.com. También puede ponerse en contacto con Boahaus en +1 (787) 688-1254 o por correo electrónico en administracion@boahaus.com. Boahaus puede requerir que los reclamos de garantía sean presentados por escrito a:

Boahaus LLC.
1250-1252
Ave. Franklin Delano Roosevelt,
San Juan, PR 00926.

Incluya su recibo de compra u otra prueba de compra y una descripción específica del defecto del producto.