

# boahaus

## ASSEMBLY INSTRUCTIONS

### ATTENTION!!!

Any inquiry or replacement parts  
you need, contact us directly at:

[contact@boahaus.com](mailto:contact@boahaus.com)

Scan this QR Code to contact to Customer Support Team.



Or Call Us at +1 281-809-4043

# boahaus

## ASSEMBLY INSTRUCTIONS V4

### INSTRUCCIONES DE ARMADO

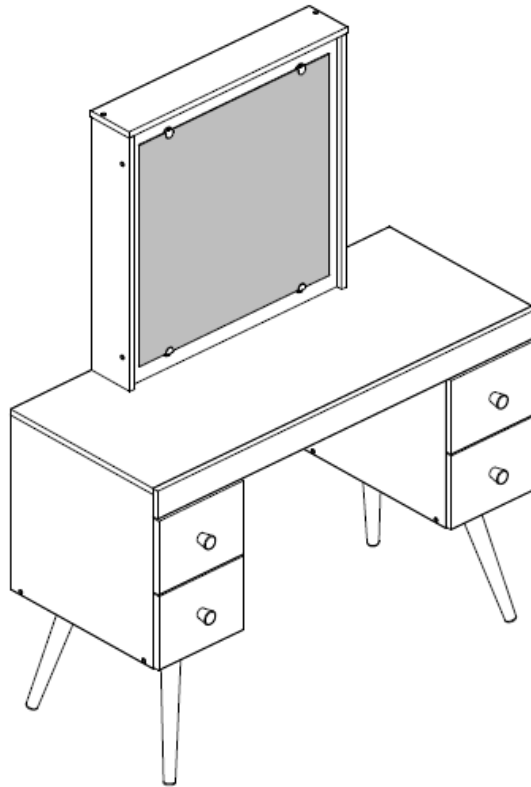

## MODEL #: 1605

### DRESSING TABLE WITH MIRROR

Tocador con espejo

Aprox. product weight 81.44 lbs. / 37 Kg.\*

\*Weight may vary +/- 5%.

Lot: See package

Production date: See package

Purchase date: \_\_\_\_\_

THIS INFORMATION BOOKLET CONTAINS IMPORTANT SAFETY INFORMATION. PLEASE READ AND KEEP FOR FUTURE REFERENCE.  
ESTE FOLLETO CONTIENE INFORMACIÓN DE SEGURIDAD IMPORTANTE. POR FAVOR, LEA Y GUÁRDELO PARA REFERENCIA FUTURA.

Need some Help? Call +1 281-809-4043 or email [contact@boahaus.com](mailto:contact@boahaus.com)  
¿Necesitas ayuda? Llama +1 281-809-4043 o envía un email [contact@boahaus.com](mailto:contact@boahaus.com)

## GENERAL SAFETY INFORMATION

1. Please read the Assembly Instructions prior to assembling this product.
2. Remove all the hardware from the box and sort by type.
3. Check to see that all the hardware and parts are present BEFORE assembling.
4. To avoid damage, assemble the product on a sturdy, level and protective surface.
5. Please wait until all steps are completed before fully tightening bolts.
6. Make sure all bolts are tightly fastened before the unit is used.
7. To move the product, you must lift it. DO NOT drag it, if you drag it can cause overturning.
8. **This product is sold with a hardware kit to be fixed on the wall. You must install this kit to prevent any accidents or damages. When properly installed, this restrain can provide protection against the unexpected tipping of the unit due to small tremors, bumps or climbing. The restrain is only a deterrent and is not a substitute for proper adult supervision. Use of tip-over restraints may only reduce, but not eliminate, the risk of tip-over**

## INFORMACIÓN GENERAL DE SEGURIDAD

1. Lea las instrucciones de armado antes de ensamblar este producto.
2. Extraiga todo el hardware de la caja y ordene por tipo.
3. Verifique que todo el hardware y las piezas están presentes ANTES de ensamblar.
4. Para evitar daños, ensamble el producto sobre una superficie resistente, nivelada y con protección.
5. Espere hasta que todos los pasos se hayan completado antes de apretar completamente los tornillos y accesorios.
6. Asegúrese de que todos los tornillos y accesorios estén bien apretados antes de usar la unidad.
7. Para mover el producto debe levantarlo. NO lo arrastre, si lo arrastra puede causar volcamiento.
8. **Este producto se vende con un kit de accesorios para ser fijado en la pared. Debe instalar este kit para evitar accidentes o daños. Cuando se instala correctamente, esta restricción puede proporcionar protección contra la inclinación inesperada de la unidad debido a temblores pequeños, golpes o al treparse. La restricción es solo un elemento disuasivo y no es un sustituto de la supervisión adecuada de un adulto. El uso de restricciones de vuelco solo puede reducir, pero no eliminar, el riesgo de volcarse.**

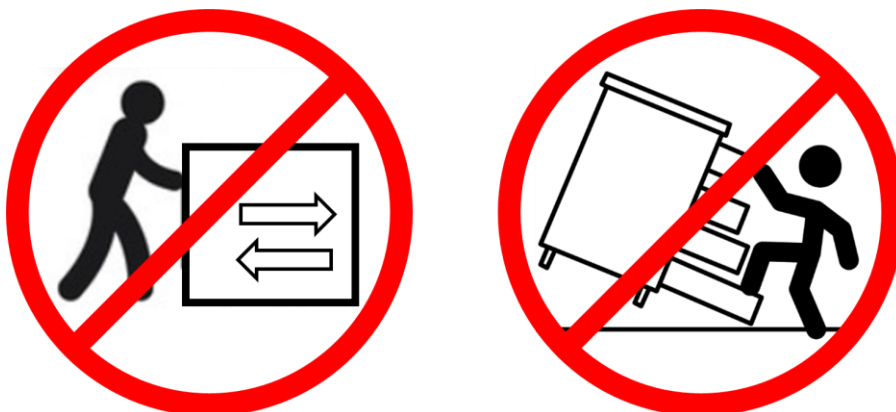

## General Dimensions / Dimensiones Generales

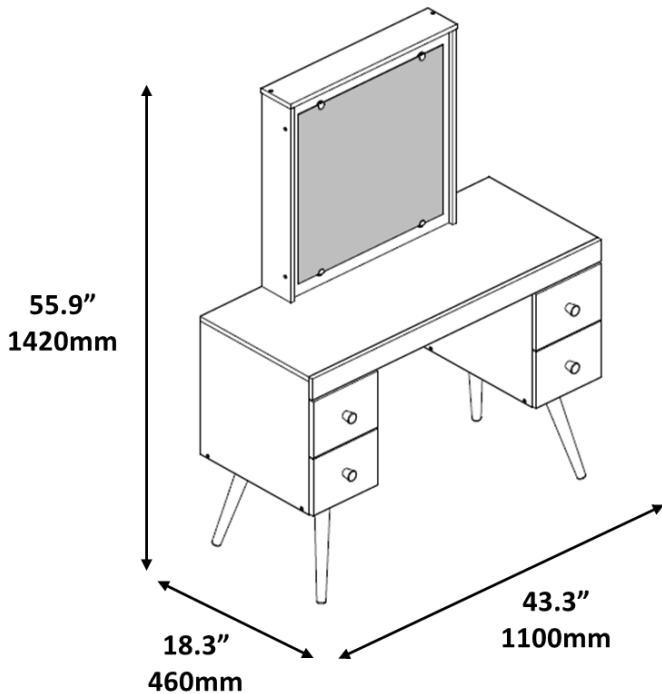

## Maximum weight supported Peso máximo soportado

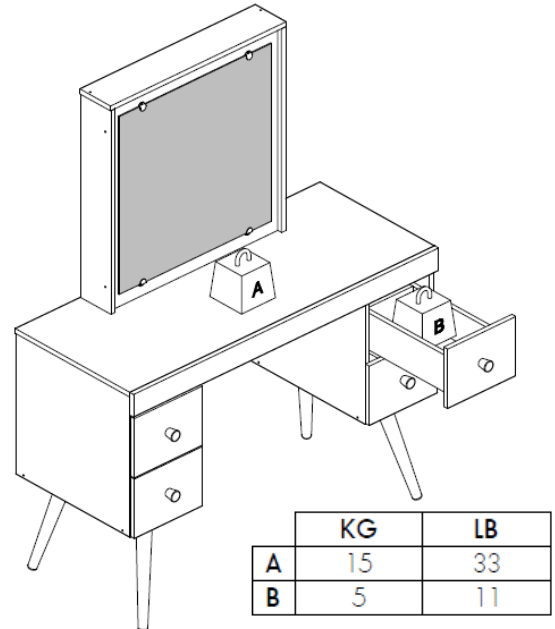

Note: weight must be evenly distributed.  
Nota: el peso debe estar distribuido uniformemente.

## You will need / usted necesitará:

Tools not included / herramientas no incluidas

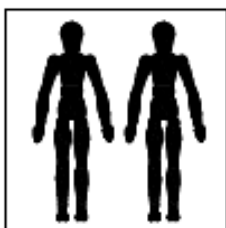

2 people  
2 personas

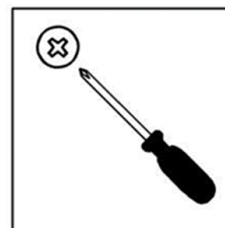

Screwdriver Phillips  
Destornillador estría

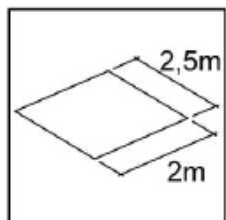

Recommended space for assemble  
Espacio recomendado para el armado



Hammer  
Martillo

**Note: Place a carpet or blanket in the assembly area to avoid damage to the parts during the process.**

**Nota: Colocar una alfombra o manta en el area de armado para evitar daños en las piezas durante el proceso.**





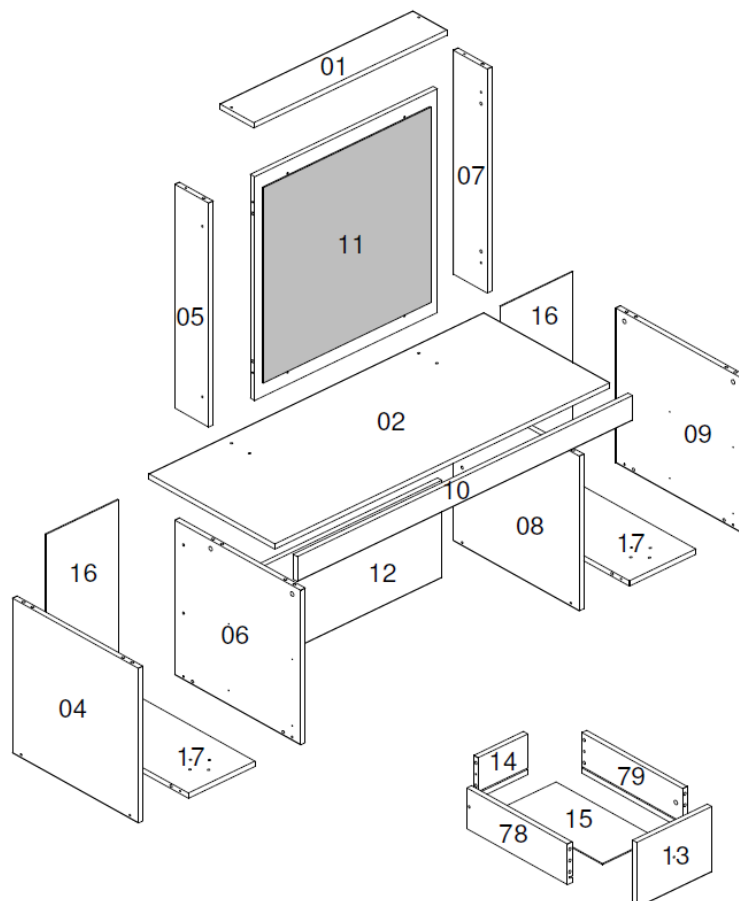







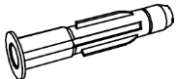
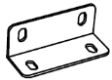
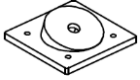

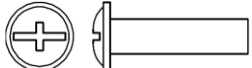
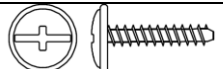
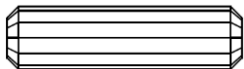
**PARTS IDENTIFICATION / IDENTIFICACION DE PARTES**

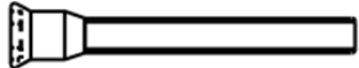



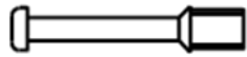

Number	Description	Qty.
01	Top tray / Travesaño superior	1
02	Top base / Base superior	1
04	Left side / Lateral izquierdo	1
05	Left side tray / Travesaño lateral izquierdo	1
06	Left partition / División izquierda	1
07	Right side tray / Travesaño lateral derecho	1
08	Right partition / División derecho	1
09	Right side / Lateral derecho	1
10	Front crossbeam / Travesaño delantero	1
11	Mirror backboard / Espejo	1
12	Back panel / Panel trasero	1
13	Front of drawer / frontal del cajón	4
14	Rear of drawer / Posterior del cajón	4
15	Bottom of drawer / Fondo del cajón	4
16	Backboard / Fondo trasero	2
17	Bottom base / Base inferior	2
78	Left side of drawer / Lateral izquierdo de cajón	4
79	Right side of drawer / Lateral izquierdo de cajón	4

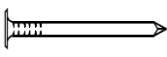

Need some Help? Call +1 281-809-4043 or email [contact@boahaus.com](mailto:contact@boahaus.com)  
 ¿Necesitas ayuda? Llama +1 281-809-4043 o envía un email [contact@boahaus.com](mailto:contact@boahaus.com)

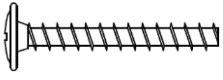
IDENTIFICATION OF ACCESSORIES / IDENTIFICACION DE ACCESORIOS

NUMBER		DESCRIPTION	QTY
A		Flanged head screw / Tornillo cabeza flangeada 5 x 60 mm	1
A1		Glue / Pegamento	1
B3		Bushing / Tapón	1
B5		Metallic angle plate / Soporte de metal	3
B12		Foot support / Soporte de pie	4
B13		Nut / Tuerca	4
D10A		Union Screw 1 / Tornillo de union 1	16
D10B		Union Screw 2 / Tornillo de union 2	16
E		Wooden dowel / Pin	58
E4		Mirror support / Soporte espejo	4
E9		Strap / Correa	1
G		Structural screw / Tornillo estructural	14
G6		Handle / Manilla	4
H		Allen key / Llave allen	1
I		Structural screw cover / Tapón de tornillo estructural	14
J		Simple minifix screw / Tornillo minifix simple	16
J9		Foot / Pie	4
L		Drum lock / Tambor minifix	16
M		Bore adhesive patch / Tapones adhesivos	8
N		Nail / Clavo	24

<b>O</b>		Flat head screw / Tornillo cabeza plana 4.5 x 45 mm	16
<b>P5</b>		Flat head screw / Tornillo cabeza plana 3.5 x 14 mm	32
<b>S</b>		Pan head screw / Tornillo cabeza pan 3.5 x 14mm	17
<b>T</b>		Flanged head screw / Tornillo cabeza flangeada 3.5 x 25 mm	4
<b>VA</b>		Metallic left slide 350mm / Corredera lateral izquierda 350mm	4
<b>VB</b>		Metallic right slide 350 mm / Corredera lateral derecha 350mm	4
<b>VC</b>		Left drawer slide 350mm / Corredera de cajón izquierda 350mm	4
<b>VD</b>		Right drawer slide 350 mm/ Corredera de cajón derecha 350 mm	4



# ATTENTION

To facilitate the assembly process, separate and organize all boards before you start.

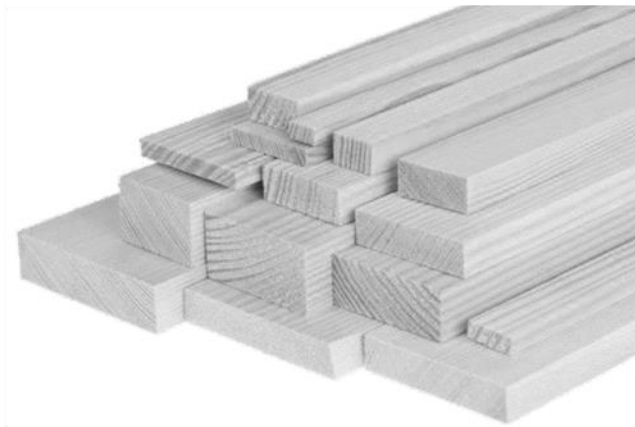

Para facilitar el armado, separa y organiza todas las tablas antes de empezar.





**PRE-ASSEMBLY / PRE- ARMADO**

1. Fix **wooden dowel (E)** and **metallic left slide (VA)** to **left side (O4)**.  
Fijar **pin (E)** y **corredera lateral izquierda (VA)** a **lateral izquierdo (O4)**.

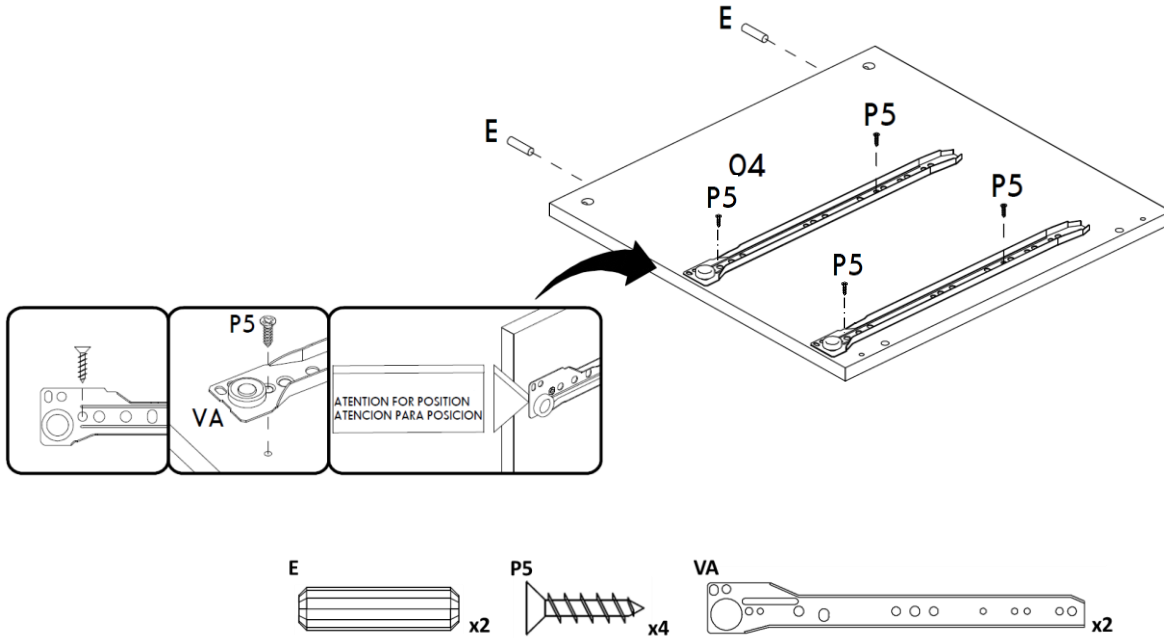

2. Fix **wooden dowel (E)** and **metallic left slide (VA)** to **right partition (O8)**.  
Fijar **pin (E)** y **corredera lateral izquierda (VA)** a **división derecha (O8)**.

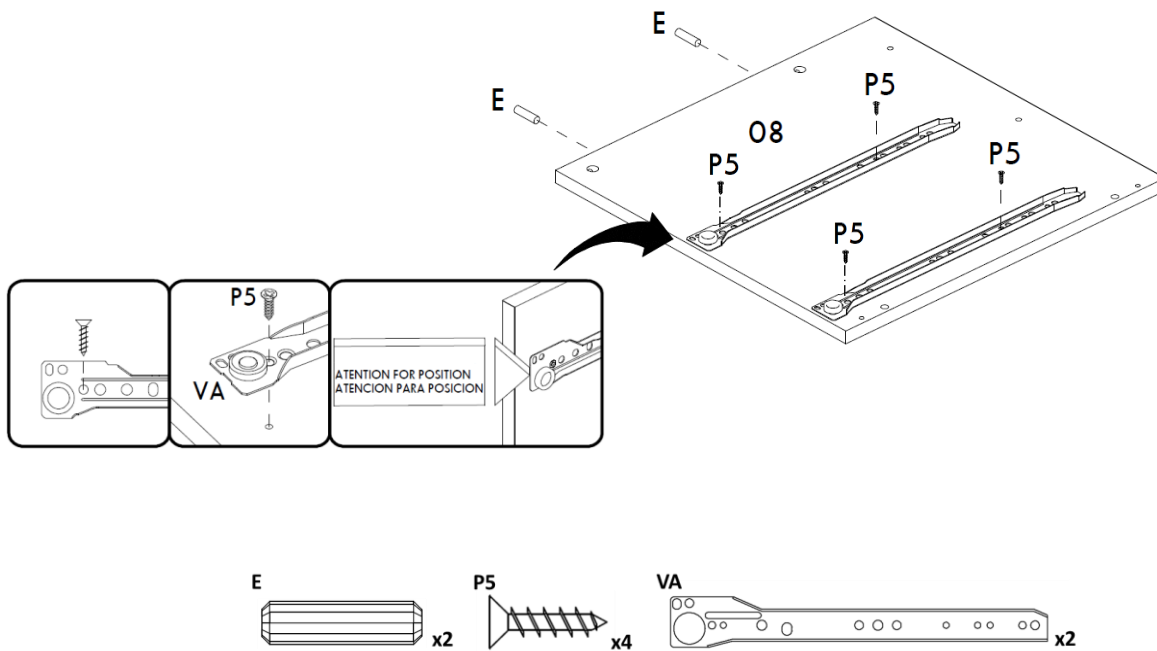

3. Fix **wooden dowel** (E) and **metallic right slide** (VB) to **right side** (09).  
 Fijar **pin** (E) y **corredera lateral derecha** (VB) a **lateral derecho** (09).

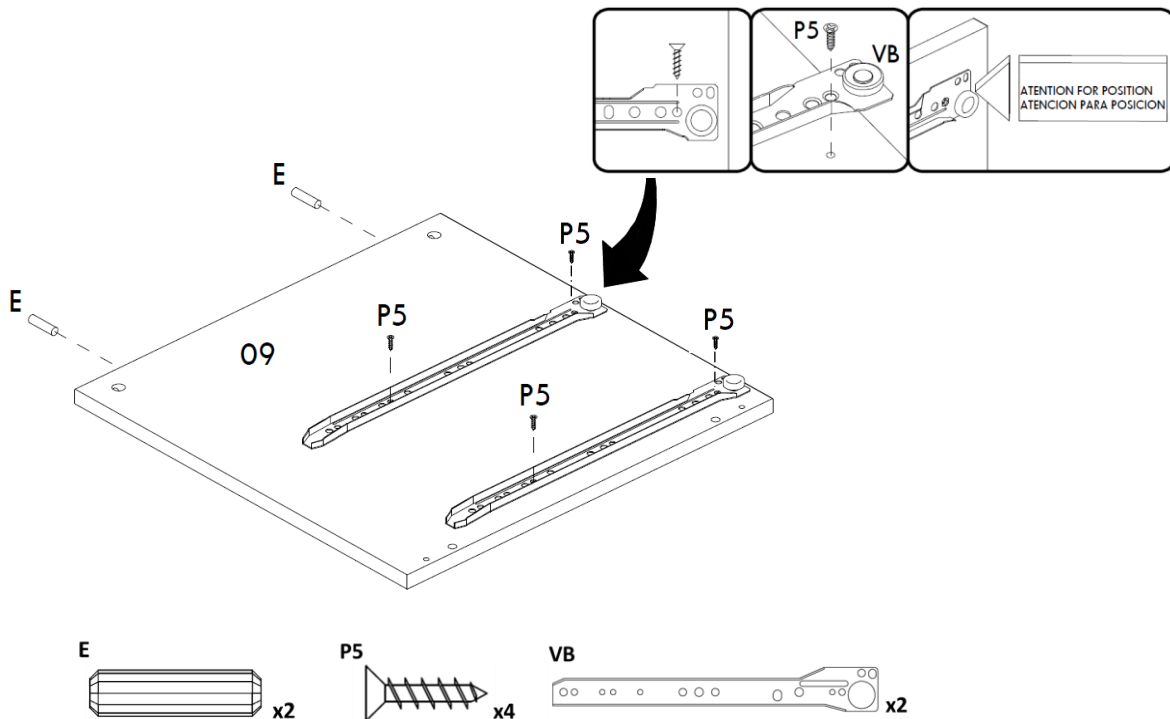

4. Fix **wooden dowel** (E) and **metallic right slide** (VB) to **left partition** (06).  
 Fijar **pin** (E) y **corredera lateral derecha** (VB) a **división izquierda** (06)

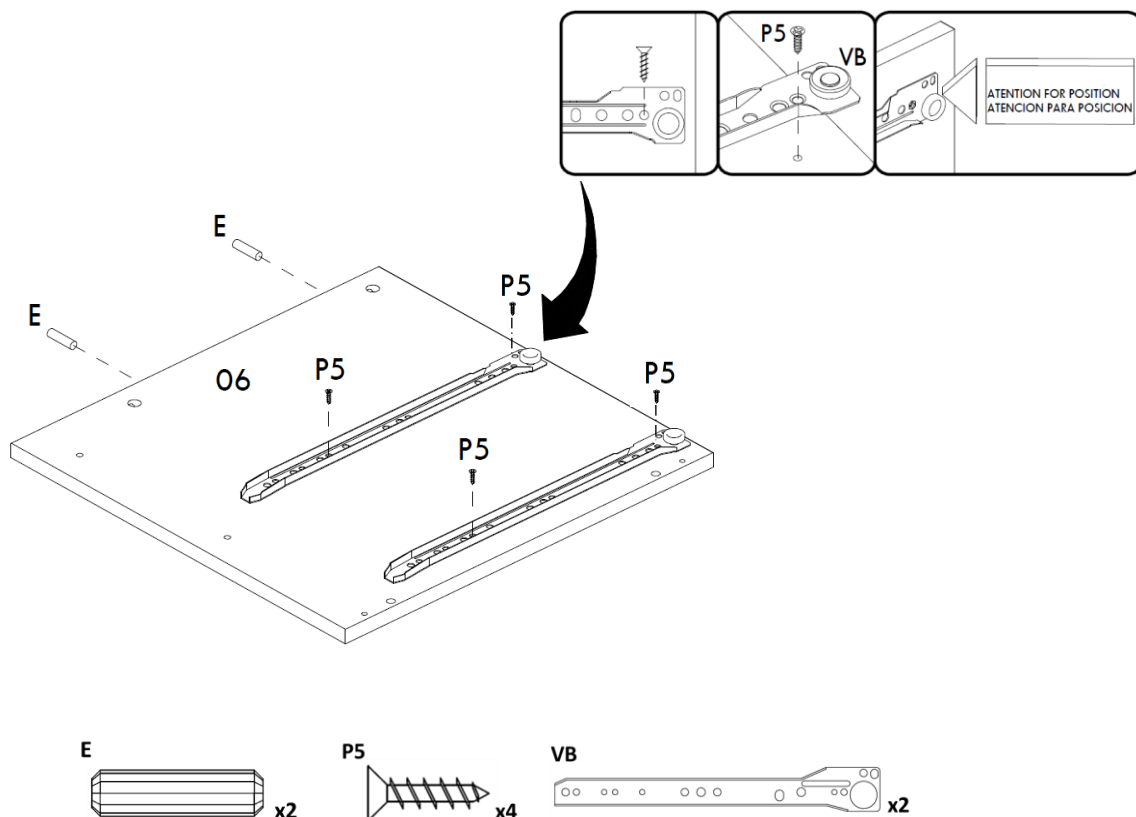

Need some Help? Call +1 281-809-4043 or email [contact@boahaus.com](mailto:contact@boahaus.com)  
 ¿Necesitas ayuda? Llama +1 281-809-4043 o envía un email [contact@boahaus.com](mailto:contact@boahaus.com)

- Fix **simple minifix screw (J)** to **top base (02)**.  
Fijar **tornillo minifix simple (J)** a **base superior (02)**.

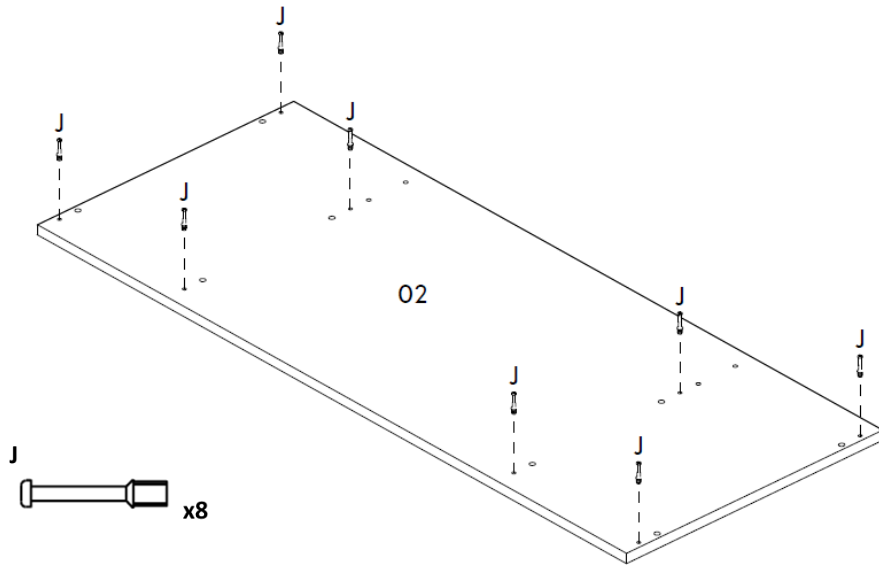

- Fix **wooden dowel (E)** to **back panel (12)**.  
Fijar **pin (E)** a **panel trasero (12)**.

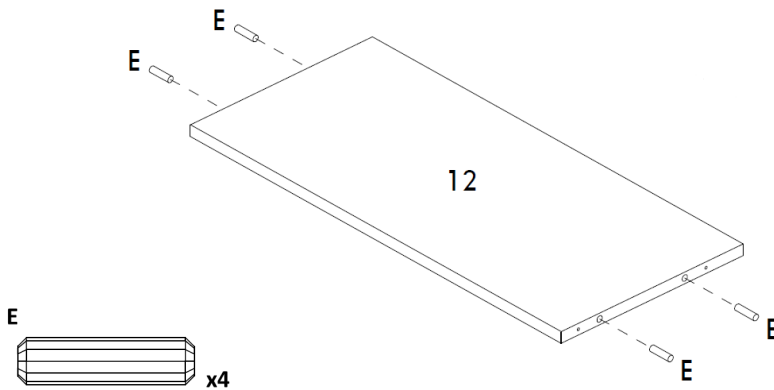

- Fix **wooden dowel (E)** to **bottom base (17) x2**.  
Fijar **pin (E)** a **base inferior (17) x2**.

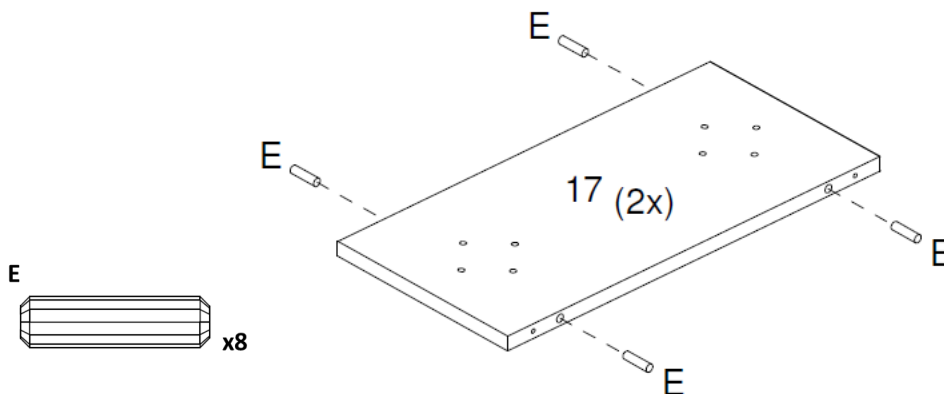

8. Fix **wooden dowel** (E) and **mirror support** (E4) to **mirror backboard** (07).  
 Fijar **pin** (E) y **soporte espejo** (E4) a **fondo espejo** (07).

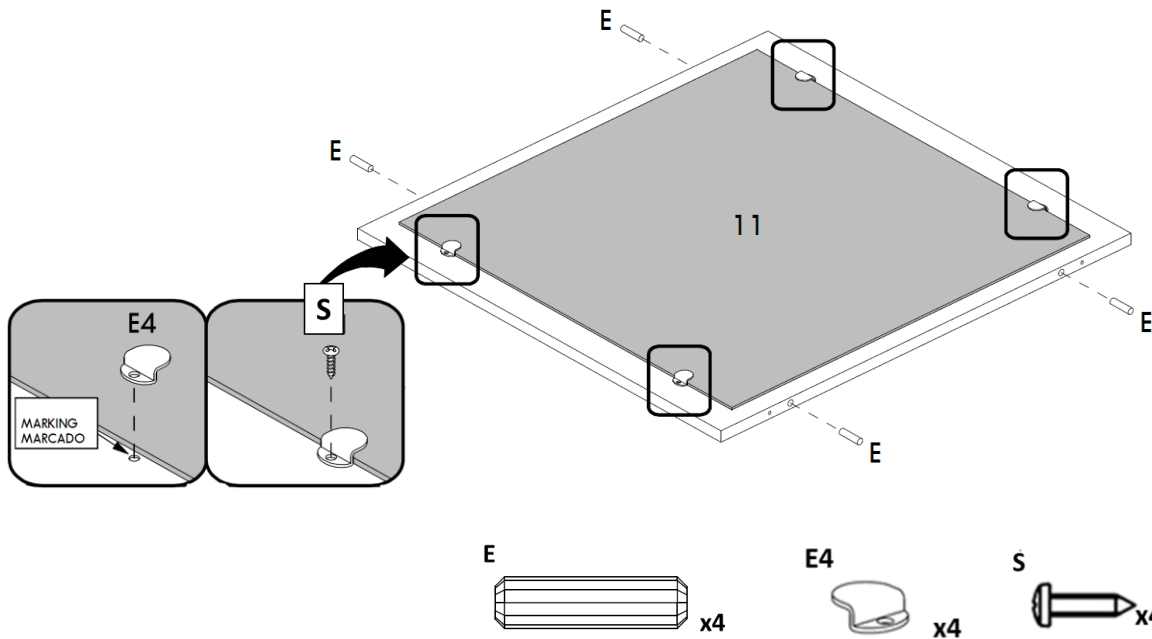

9. Fix **wooden dowel** (E) to **left side tray** (05) and **right side tray** (07).  
 Fijar **pin** (E) a **travesaño izquierdo** (05) y a **travesaño derecho** (07).

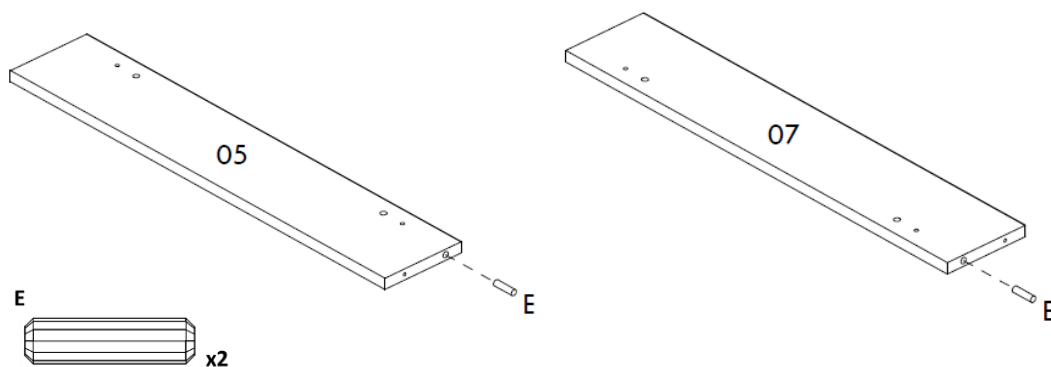

10. Fix **simple minifix screw** (J) to **front of drawer** (13) x4.  
 Fijar **tornillo minifix simple** (J) a **frontal del cajón** (13) x4.

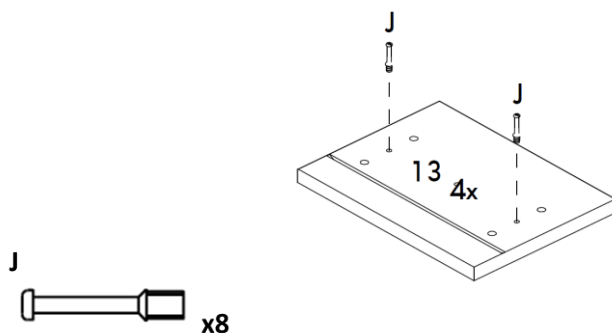

11. Fix **wooden dowel** (E) to **left side of drawer** (78) x4, **right side of drawer** (79) x4.  
 Fijar **pin** (E) a **lateral izquierdo de cajón** (78) x4, **lateral derecho de cajón** (79) x4

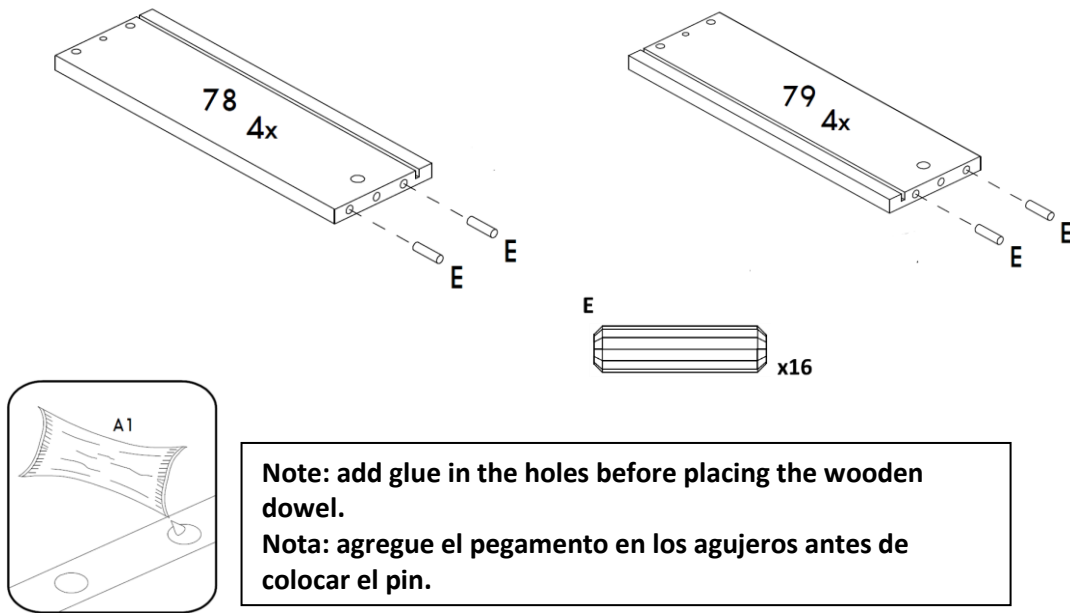

12. Fix **wooden dowel** (E) to **rear of drawer** (14) x4.  
 Fijar **pin** (E) a **posterior de cajón** (14) x4.

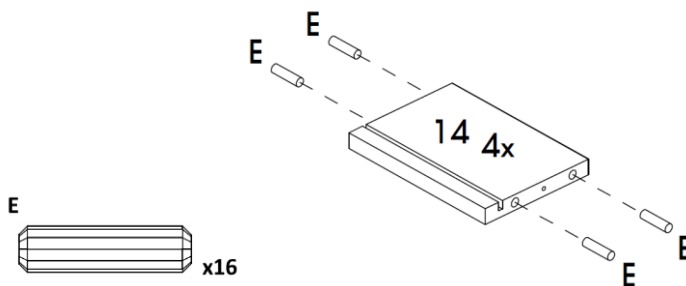

13. Fix **metallic angle plate** (B5) to **front crossbeam** (10).  
 Fijar **soporte de metal** (B5) a **travesaño frontal** (10).

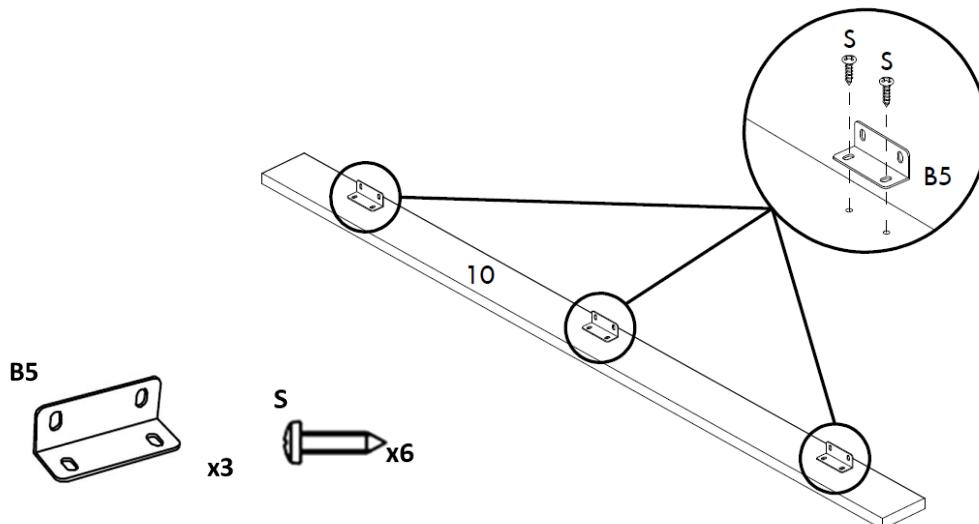

Need some Help? Call +1 281-809-4043 or email [contact@boahaus.com](mailto:contact@boahaus.com)  
 ¿Necesitas ayuda? Llama +1 281-809-4043 o envía un email [contact@boahaus.com](mailto:contact@boahaus.com)

14. Fix *nut* (B13) to *foot support* (B12) x4.  
Fijar *tuerca* (B13) a *soporte pie* (B12) x4.

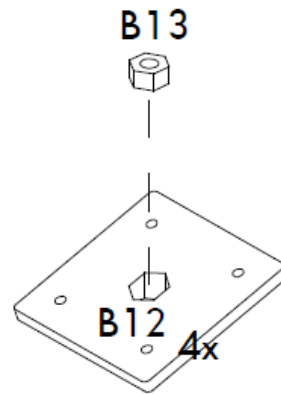

## ASSEMBLY / ARMADO

15. Fix **left side tray** (05) and **right side tray** (07) to **mirror backboard** (11)  
 Fijar **travesaño izquierdo** (05) y **travesaño derecho** (07) a **fondo espejo** (11).

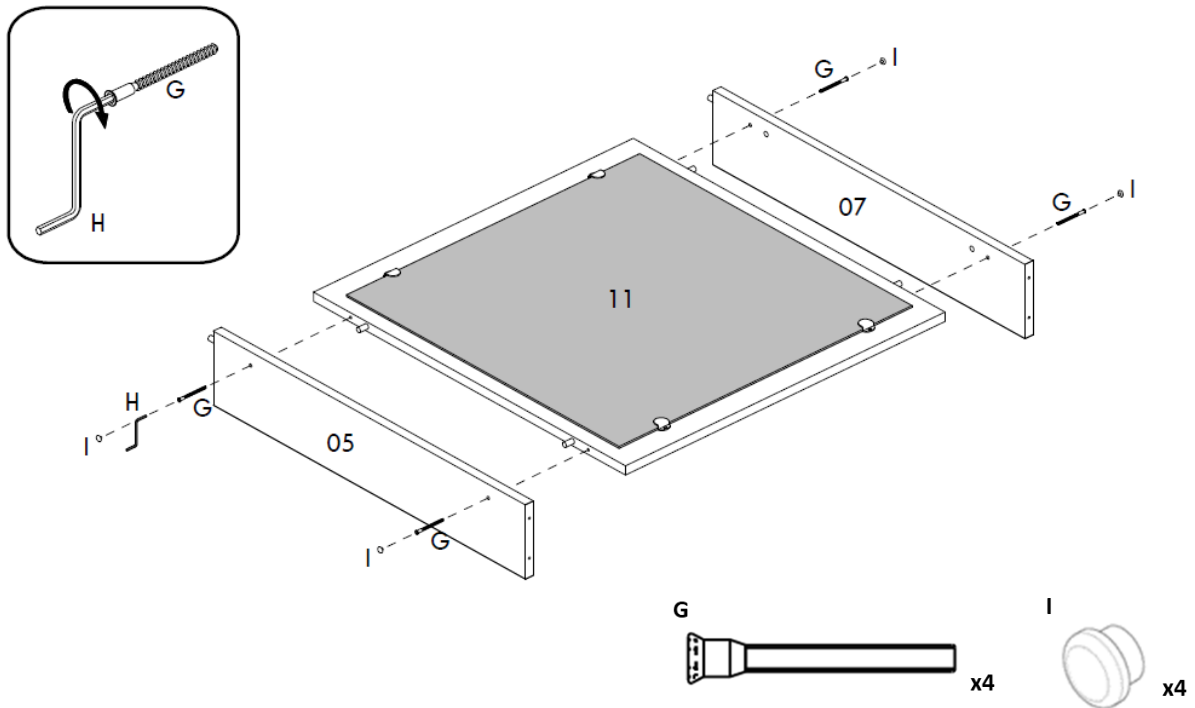

16. Fix **top tray** (01) to previous assembly.  
 Fijar **travesaño superior** (01) a ensamble previo.

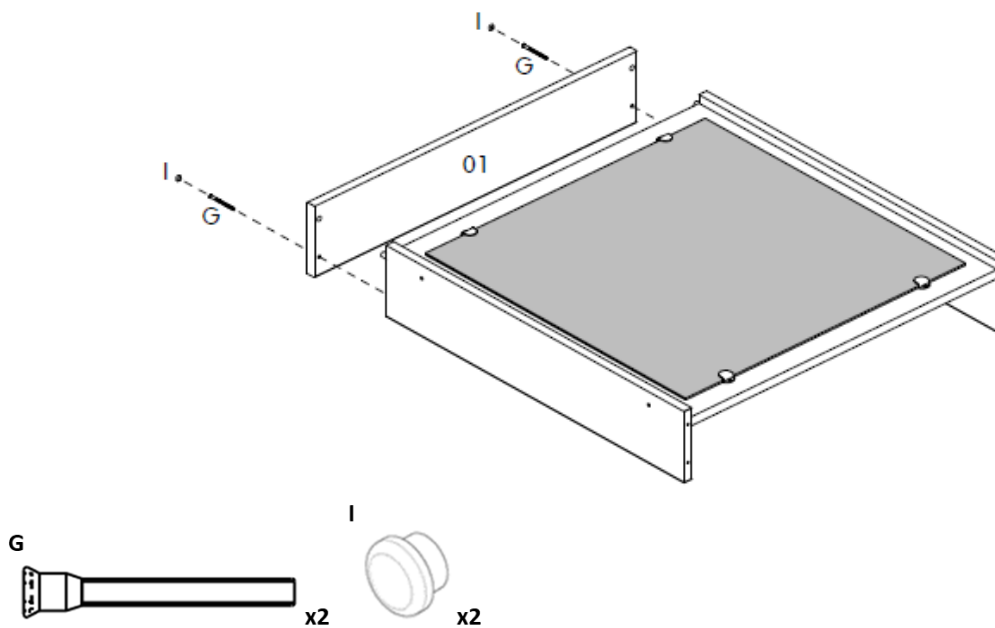

17. Fix **top base** (02) to previous assembly.  
 Fijar **base superior** (02) a ensamble previo.

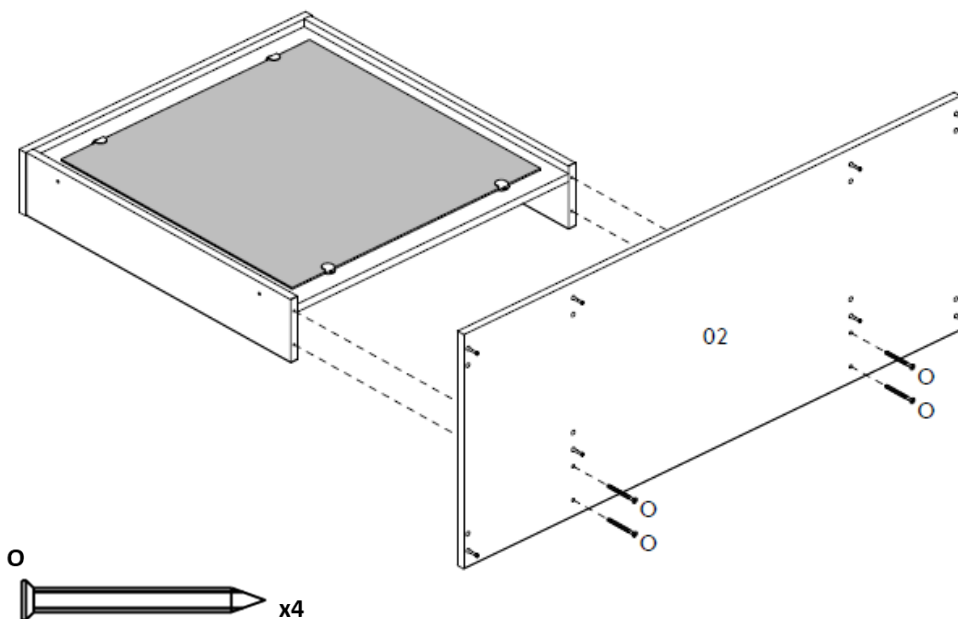

18. Fix **back panel** (12) to **left partition** (06).  
 Fijar **panel trasero** (12) a **división izquierda** (06).

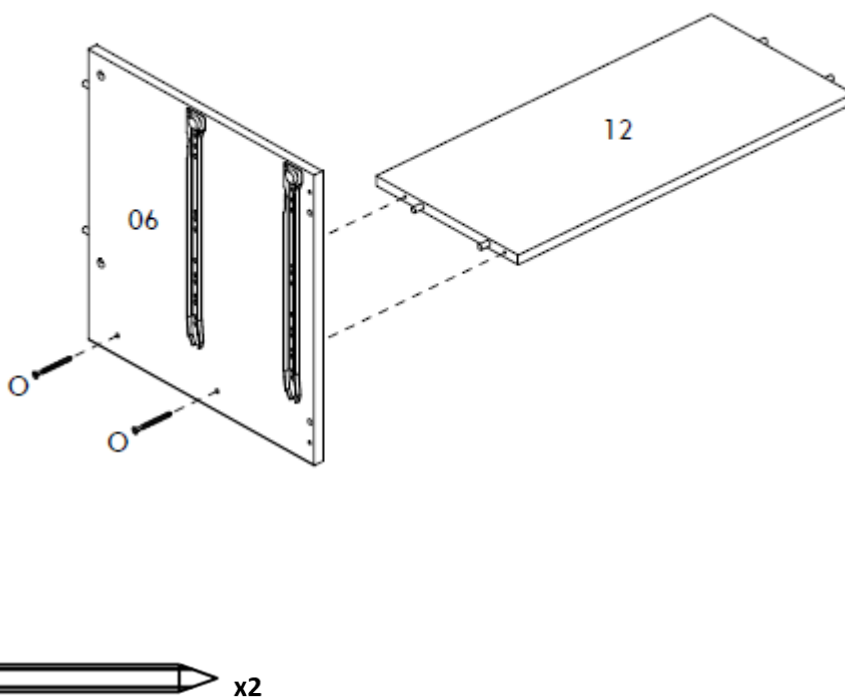



19. Fix **right partition** (08) to previous assembly.  
 Fijar **división derecha** (08) a ensamble previo.

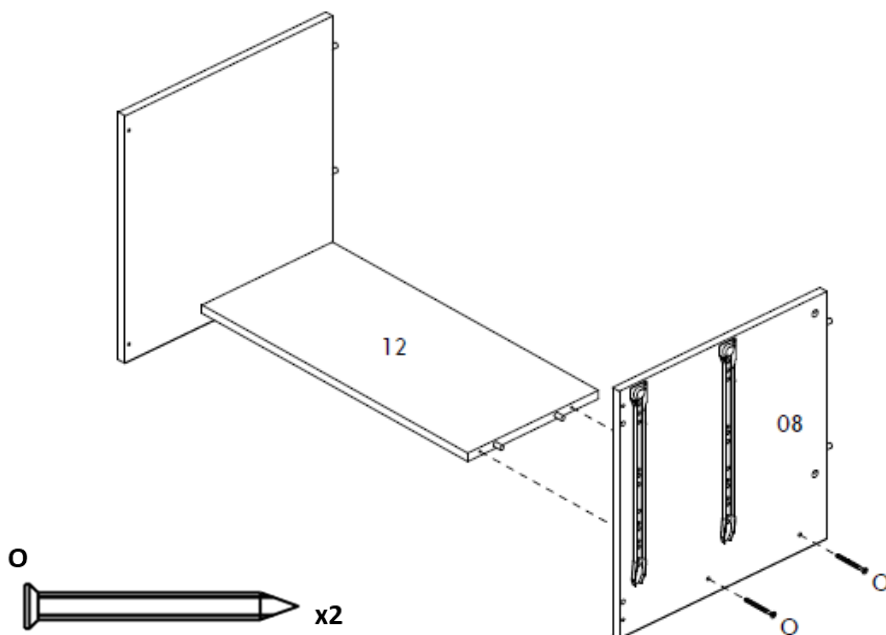

20. Fix **bottom base** (17) x2 to previous assembly.  
 Fijar **base inferior** (17) x2 a ensamble previo.

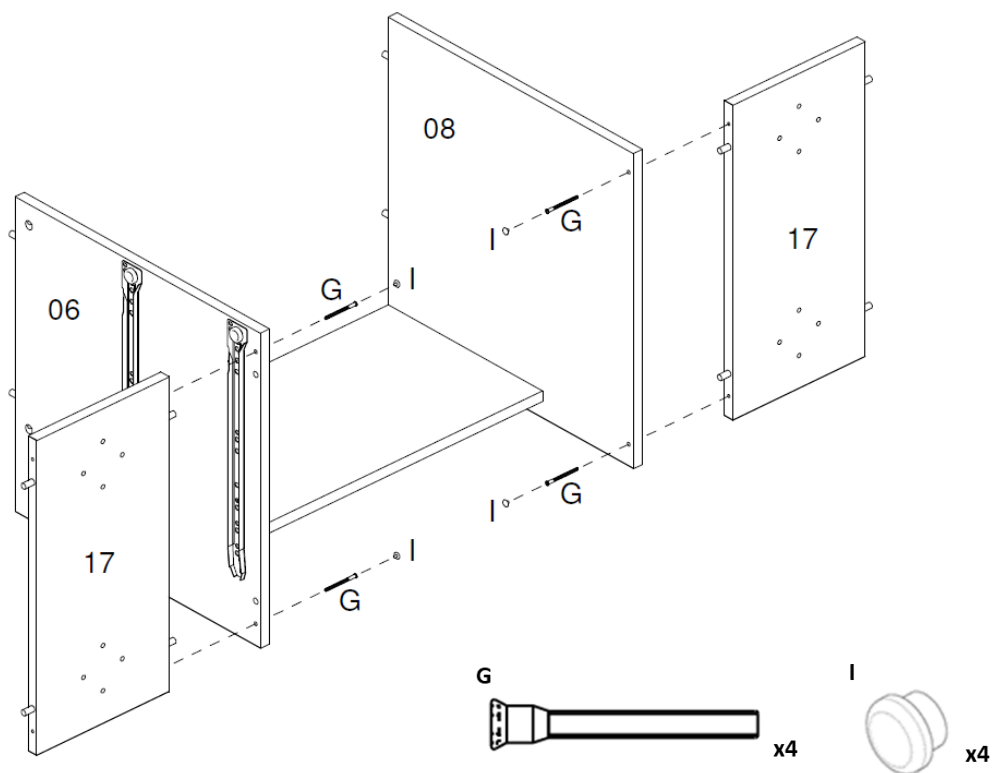

21. Fix **left side** (04) to previous assembly.

Fijar **lateral izquierdo** (04) a ensamble previo.

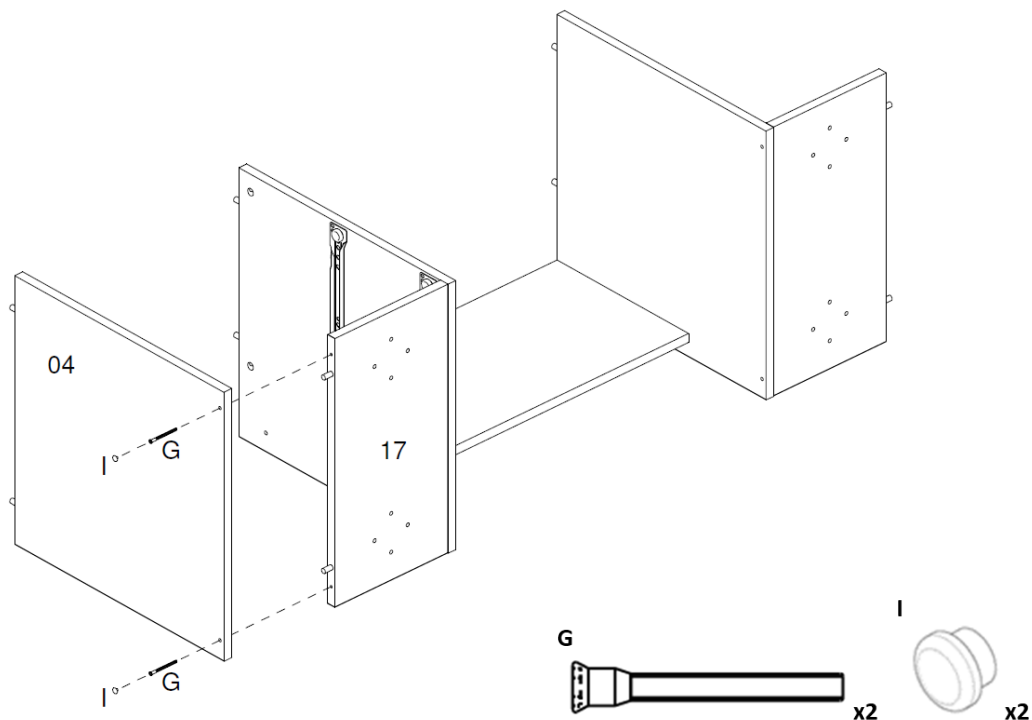

22. Fix **right side** (09) to previous assembly.

Fijar **lateral derecho** (09) a ensamble previo.

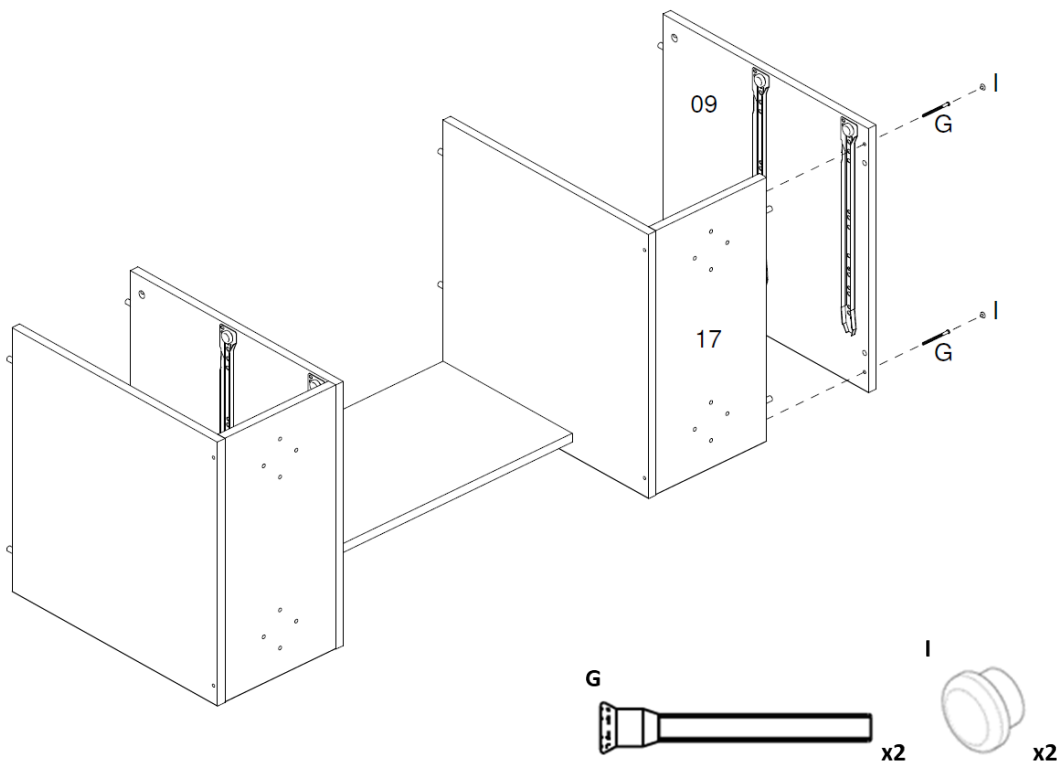

23. Join step 17 and step 22.  
Unir paso 17 y paso 22.

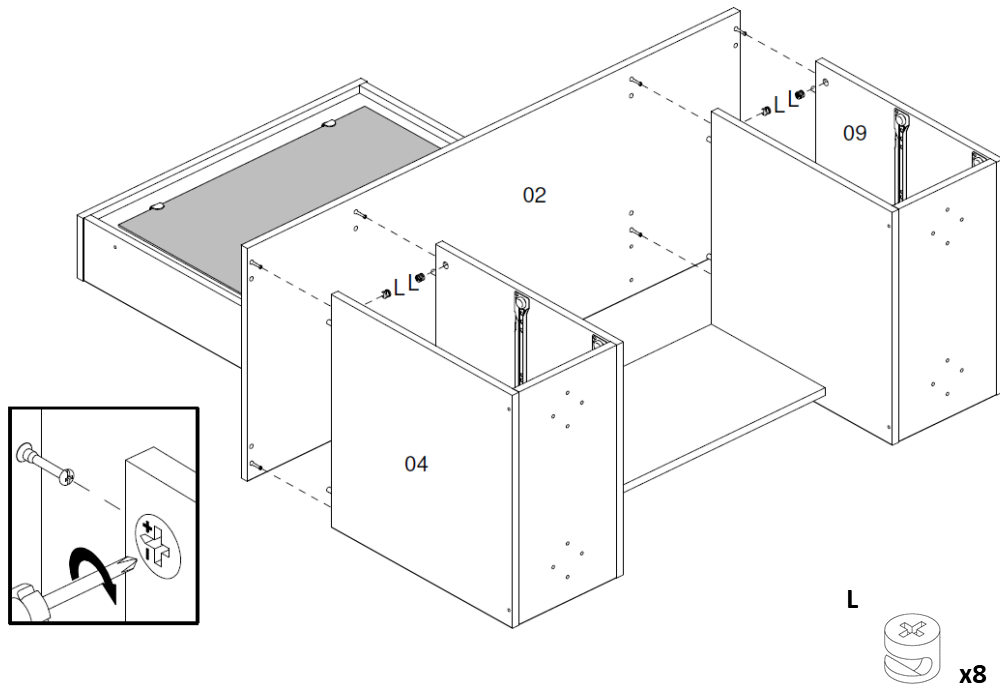

24. Fix **front crossbeam** (10) to previous assemble.  
Fijar **travesaño frontal** (10) a ensamble previo.

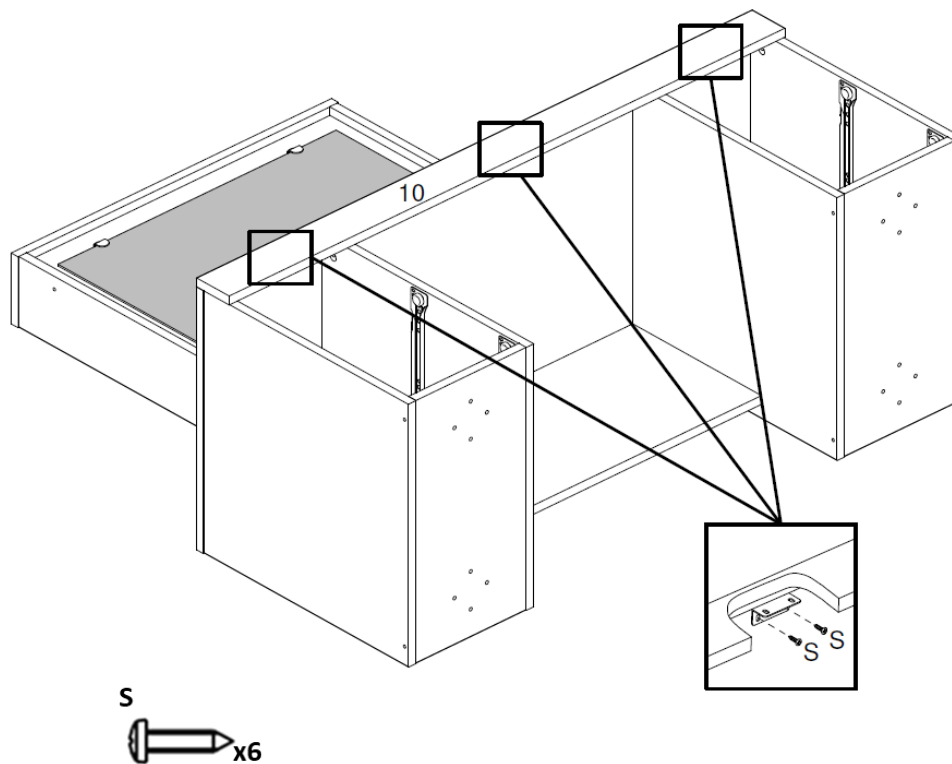

25. Fix **foot support** (B12) x4 to previous assembly.  
 Fijar **soporte de pie** (B12) x4 a ensamble previo.

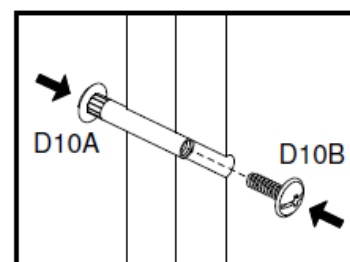
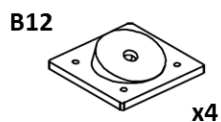
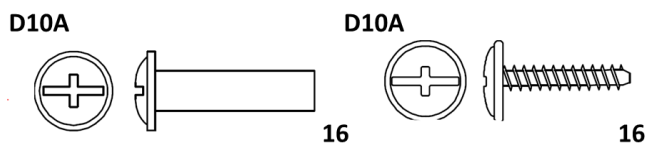
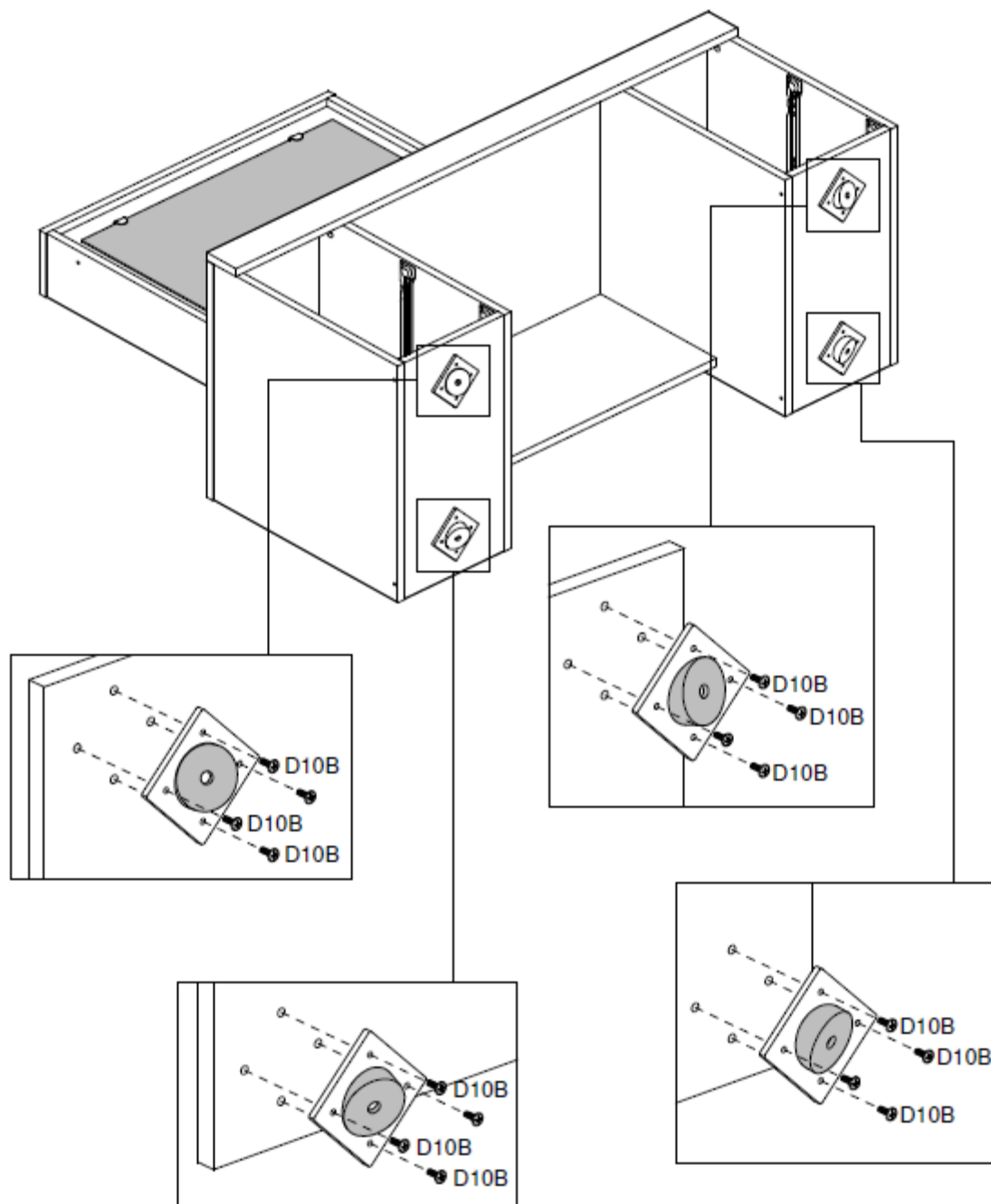

26. Fix **foot** (J9) x4 to previous assembly.  
 Fijar **pie** (J9) x4 a ensamble previo.

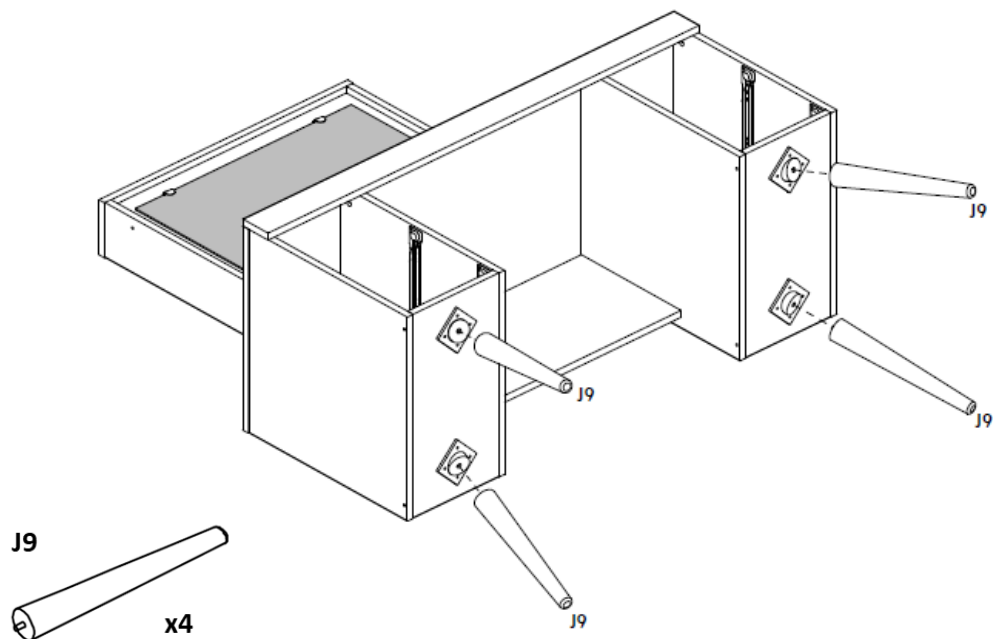

27. Fix **backboard** (16) x2 to previous assembly.  
 Fijar **fondo trasero** (16) x2 a ensamble previo.

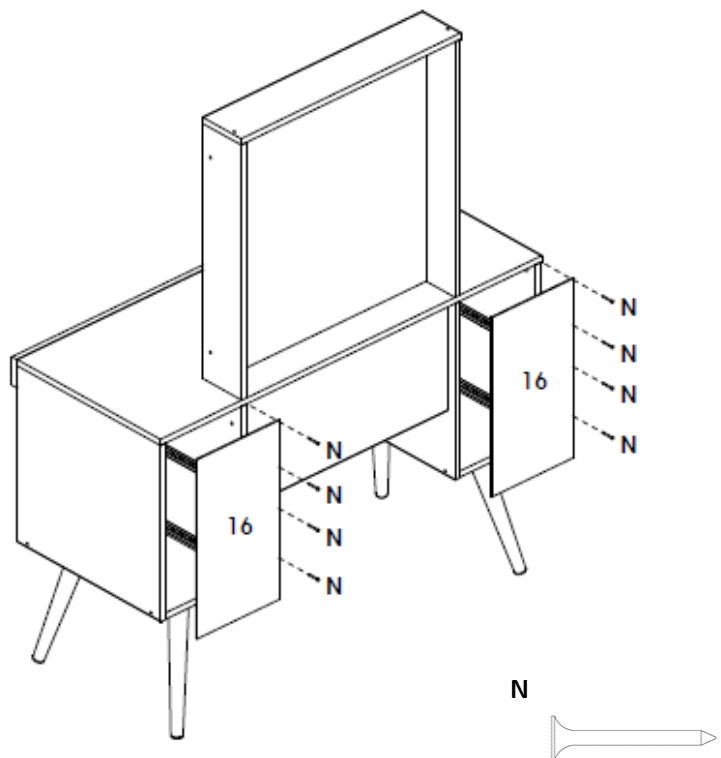

28. Assemble drawer x4.  
Ensamblar cajón x4.

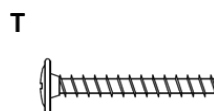
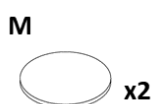
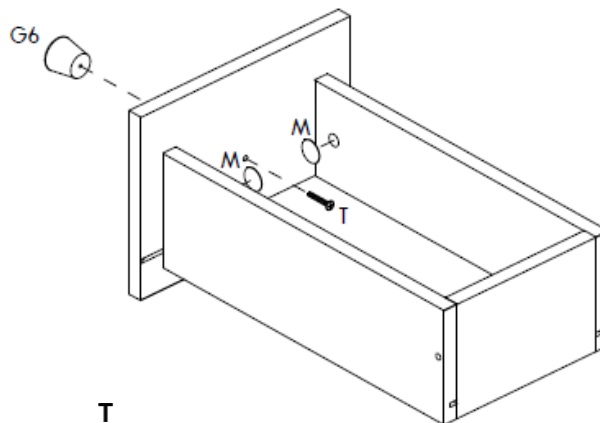
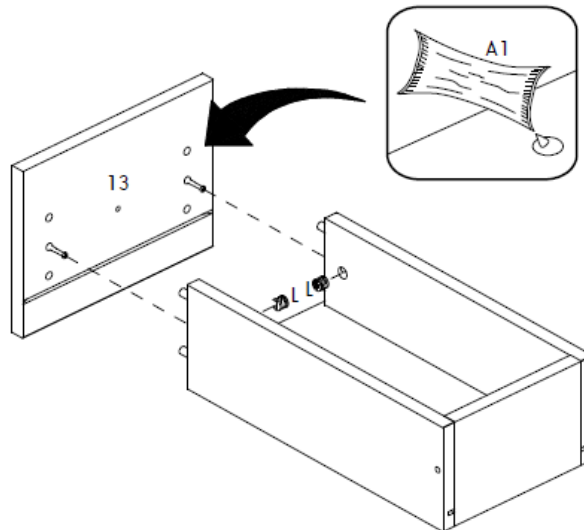
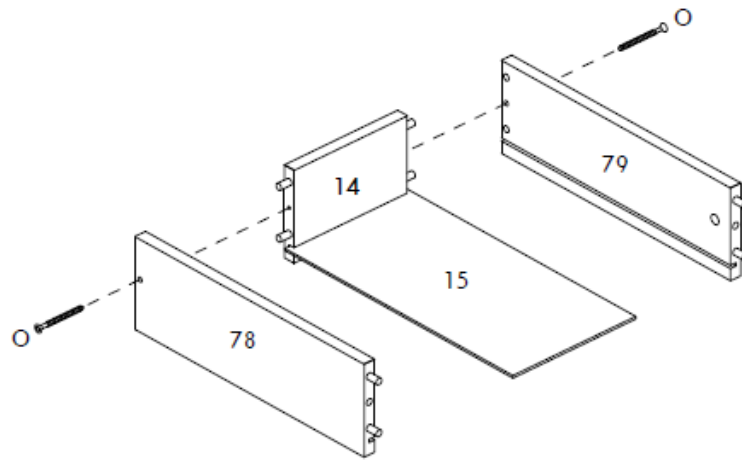

Need some Help? Call +1 281-809-4043 or email [contact@boahaus.com](mailto:contact@boahaus.com)  
 ¿Necesitas ayuda? Llama +1 281-809-4043 o envía un email [contact@boahaus.com](mailto:contact@boahaus.com)

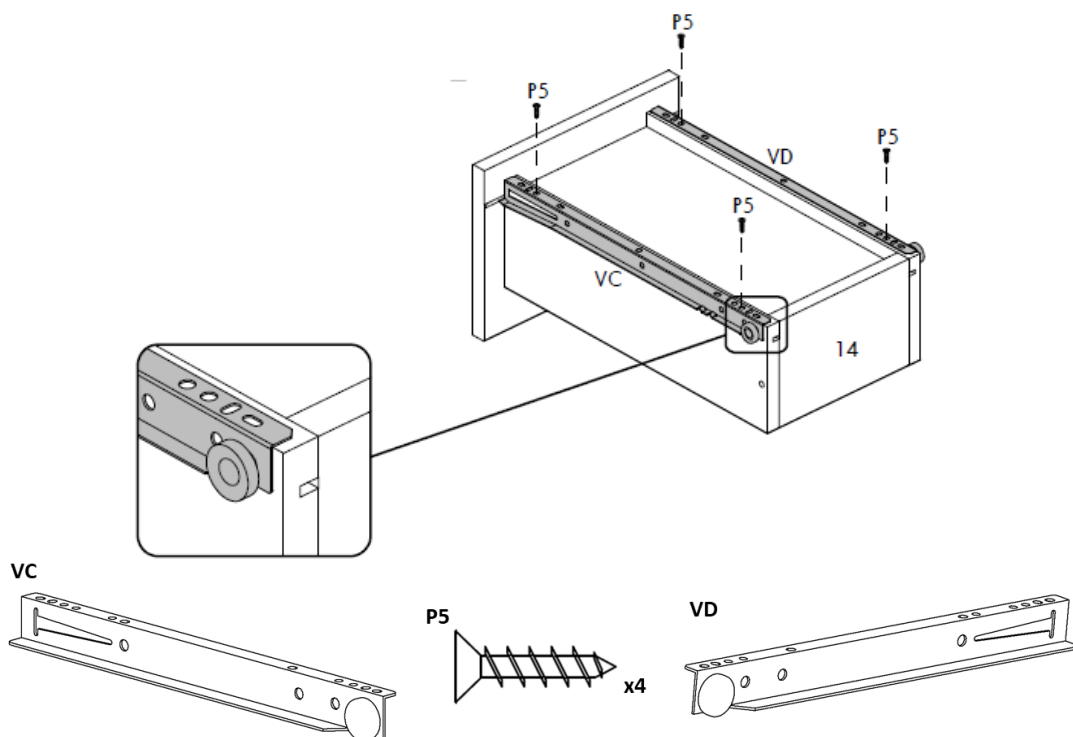

29. Fix furniture to the wall.  
Fijar mueble a la pared.

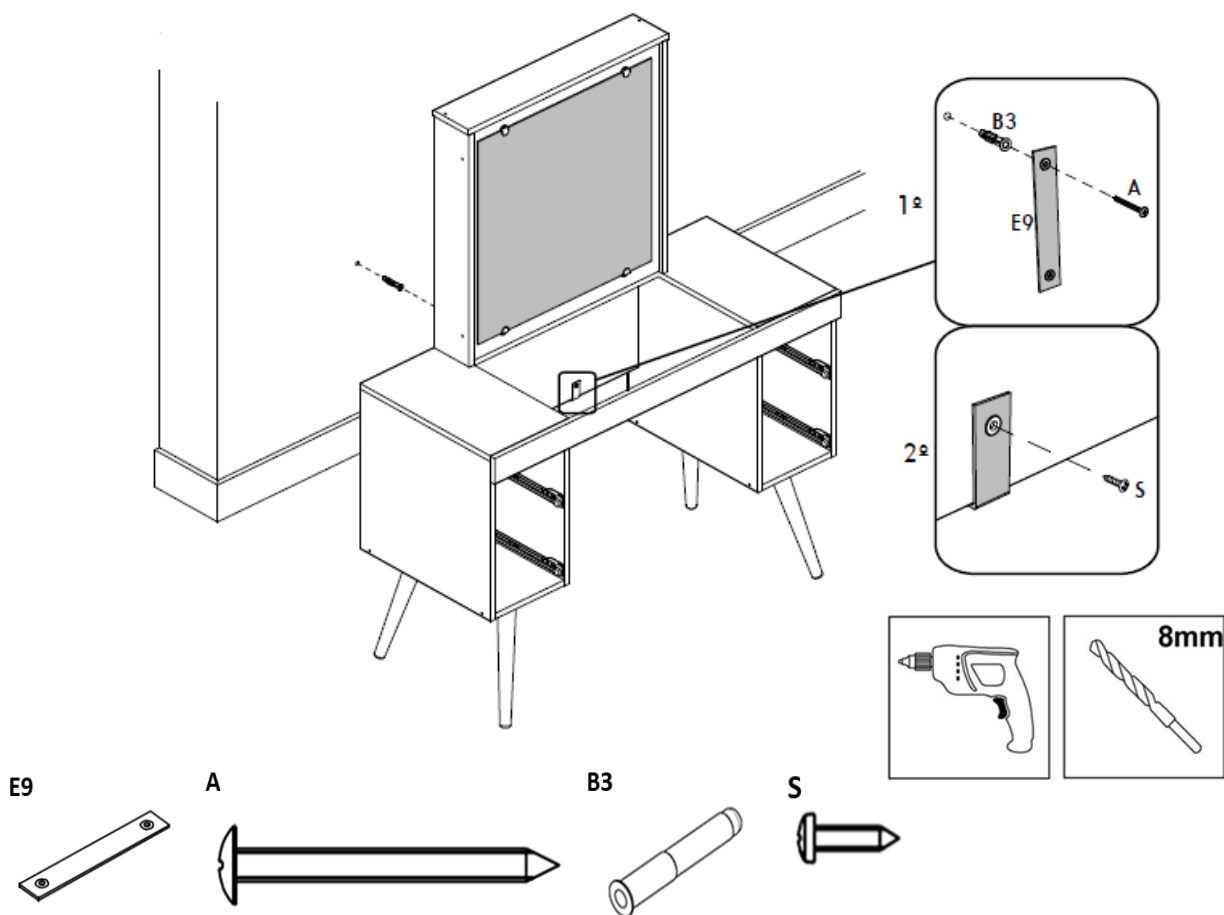

Need some Help? Call +1 281-809-4043 or email [contact@boahaus.com](mailto:contact@boahaus.com)  
¿Necesitas ayuda? Llama +1 281-809-4043 o envía un email [contact@boahaus.com](mailto:contact@boahaus.com)

30. And finally place drawers in the furniture.  
Y finalmente colocar las gavetas en el mueble.

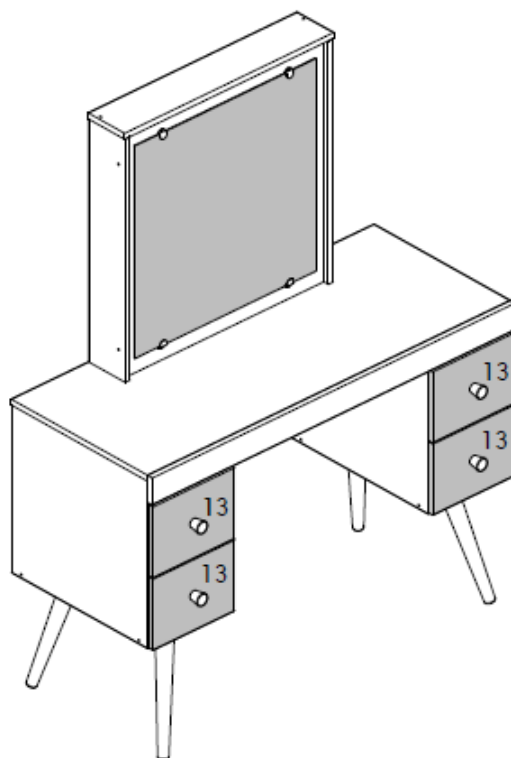

***Congratulations, you have assembled your Dressing Table with Mirror!!!  
¡¡¡Felicitaciones, has armado tu Tocador con Espejo!!!***



## 1605 Boahaus Dressing Table with Mirror Warranty

### 6-Months Limited Warranty

1. Boahaus, LLC provides limited warranty coverage to the original purchaser of this product for a period of six months from the date of purchase against defects in materials or workmanship of Boahaus furniture components. As used in this Warranty, “defect” means imperfections in components which substantially impair the utility of the product. This Warranty gives you specific legal rights, and you may also have other rights which vary from state to state.
2. There is no warranty coverage for defects or conditions that result from the failure to follow product assembly instructions, information or warnings, misuse or abuse, intentional damage, fire, flood, alteration or modification of the product, or use of the product in a manner inconsistent with its intended use, nor any condition resulting from incorrect or inadequate maintenance, cleaning, or care. There is also no warranty coverage for rented products or any products purchased “used” or “as is”, at a distress or going-out-of business sale, or from a liquidator.
3. As the exclusive remedy under this Warranty, Boahaus will (at its sole option) repair, replace or refund the value of any defective furniture component. Boahaus may require independent confirmation of the claimed defect and proof of purchase. Replacement parts will be warranted for only the remaining period of the original Warranty. BOAHAUS SHALL HAVE NO LIABILITY for ANY INCIDENTAL OR CONSEQUENTIAL DAMAGES OF ANY KIND and all such damages are EXCLUDED FROM THIS WARRANTY, such as loss of use, disassembly, transportation, labor or damage to property on or near the product. Some states do not allow the exclusion or limitation of incidental or consequential damages, so the above limitation or exclusion may not apply to you.
4. This Warranty applies only to warranted defects that first arise and are reported to Boahaus within the warranty coverage period. The Warranty cannot be transferred to subsequent owners or users of the product, and it shall be immediately void in the event the product is resold, transferred, leased or rented to any third party or person other than the original purchaser.
5. THERE ARE NO OTHER WARRANTIES APPLICABLE TO THIS PRODUCT. Under the laws of certain states, there may be no implied warranties from Boahaus and all implied warranties, INCLUDING ANY IMPLIED WARRANTY OF MERCHANTABILITY OR FITNESS FOR A PARTICULAR PURPOSE are disclaimed where allowed by law. TO THE EXTENT ANY IMPLIED WARRANTIES ARE APPLICABLE, ANY IMPLIED WARRANTIES, INCLUDING ANY IMPLIED WARRANTY OF MERCHANTABILITY OR FITNESS FOR A PARTICULAR PURPOSE, ARE LIMITED IN DURATION TO THE DURATION OF THIS EXPRESS WARRANTY or the minimum period allowed by law, whichever is shorter. Some states do not allow limitations on how long an implied Warranty lasts, so the above limitation may not apply to you.
6. For Warranty inquiries, questions about disposition or claims, please visit our website [www.boahaus.com](http://www.boahaus.com). You can also contact Boahaus at **+1 281-809-4043** or email at [contact@boahaus.com](mailto:contact@boahaus.com). Boahaus may require Warranty claims to be submitted in writing to:

Boahaus LLC.  
1250-1252  
Ave. Franklin Delano Roosevelt,  
San Juan, PR 00926.

Please include your sales receipt or other proof of purchase and a specific description of the product defect.

## Garantía de Tocador con Espejo 1605 Boahaus

### Garantía limitada de 6 meses

1. Boahaus, LLC proporciona cobertura de garantía limitada al comprador original de este producto por un período de 6 meses a partir de la fecha de compra contra defectos en materiales o mano de obra de componentes de muebles de Boahaus. Como se especifica en esta Garantía, "defecto" significa imperfecciones en componentes que perjudican sustancialmente la utilidad del producto. Esta Garantía le otorga derechos legales específicos y también puede tener otros derechos que varían de un estado a otro.
2. No hay cobertura de garantía por defectos o condiciones que resulten del incumplimiento de las instrucciones del producto, o advertencias, uso indebido o abuso, daño intencional, incendio, inundación, alteración o modificación del producto o uso del producto de manera inconsistente con su uso previsto, o cualquier condición resultante de mantenimiento incorrecto o inadecuado, limpieza o cuidado. Tampoco hay cobertura de garantía para productos alquilados o cualquier producto comprado "usado" o "tal cual", en una venta de emergencia o de salida de la empresa, o de un liquidador.
3. Boahaus puede requerir una confirmación independiente del defecto reclamado y un comprobante de compra. Las piezas de repuesto estarán garantizadas durante el período restante de la garantía original. BOAHAUS NO TENDRÁ NINGUNA RESPONSABILIDAD POR CUALQUIER DAÑO INCIDENTAL y todos estos daños ESTÁN EXCLUIDOS DE ESTA GARANTÍA, tales como pérdida de uso, desmontaje, transporte, mano de obra o daños a la propiedad en o cerca del producto. Algunos estados no permiten la exclusión o limitación de daños incidentales o consecuentes, por lo que la limitación o exclusión anterior puede no aplicarse a usted.
4. Esta Garantía se aplica únicamente a los defectos garantizados que surgen y se informan a Boahaus dentro del período de cobertura de la garantía. La garantía no puede ser transferida a los propietarios o usuarios posteriores del producto, y será inmediatamente nula en caso de que el producto sea revendido, transferido, arrendado o alquilado a cualquier tercero o persona que no sea el comprador original.
5. NO HAY OTRAS GARANTÍAS APLICABLES A ESTE PRODUCTO. Bajo las leyes de ciertos estados, no puede haber garantías implícitas de Boahaus y todas las garantías implícitas, INCLUYENDO CUALQUIER GARANTÍA IMPLÍCITA DE COMERCIABILIDAD O ADECUACIÓN PARA UN PROPÓSITO EN PARTICULAR, están exoneradas cuando permitido por la ley. TODAS LAS GARANTÍAS IMPLÍCITAS SON APLICABLES, LAS GARANTÍAS IMPLÍCITAS, INCLUIDAS CUALQUIER GARANTÍA IMPLÍCITA DE COMERCIABILIDAD O ADECUACIÓN PARA UN PROPÓSITO PARTICULAR, ESTÁN LIMITADAS EN DURACIÓN A LA DURACIÓN DE ESTA GARANTÍA EXPRESA o el período mínimo permitido por la ley, cualquiera que sea más corto. Algunos estados no permiten limitaciones sobre la duración de una garantía implícita, por lo que es posible que la limitación anterior no se aplique a usted.
6. Para consultas sobre la garantía, preguntas sobre la disposición o reclamaciones, visite nuestro sitio web [www.boahaus.com](http://www.boahaus.com). También puede ponerse en contacto con Boahaus en **+1 281-809-4043** o por correo electrónico en [contact@boahaus.com](mailto:contact@boahaus.com). Boahaus puede requerir que los reclamos de garantía sean presentados por escrito a:

Boahaus LLC.  
1250-1252  
Ave. Franklin Delano Roosevelt,  
San Juan, PR 00926.

Incluya su recibo de compra u otra prueba de compra y una descripción específica del defecto del producto.