

ASSEMBLY INSTRUCTIONS MANUAL DE MONTAGEM / INSTRUCCIONES DE ARMADO

ZAIRA WARDROBE - 3 DOORS

ROUPEIRO ZAIRA 3 PORTAS

ROPERO ZAIRA - 3 PUERTAS

Reference
Referência
Referencia

210434

Revised
Revisão
Revisión

00



ENGLISH
PORTUGUÊS
ESPAÑOL

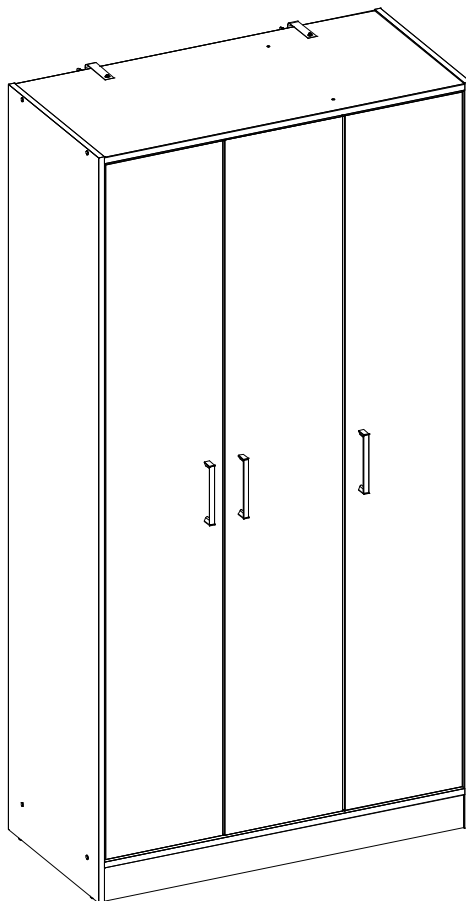

MAXIMUM RECOMMENDED WEIGHT
BEING THIS EVENLY DISTRIBUTED.

PESO MÁXIMO RECOMENDADO SENDO
ESTE DISTRIBUÍDO UNIFORMEMENTE.

PESO MÁXIMO RECOMENDADO SIENDO
ESTE UNIFORMEMENTE DISTRIBUIDO.

	LB	KG
–		
D	11	5
E	17	8
G	33	15

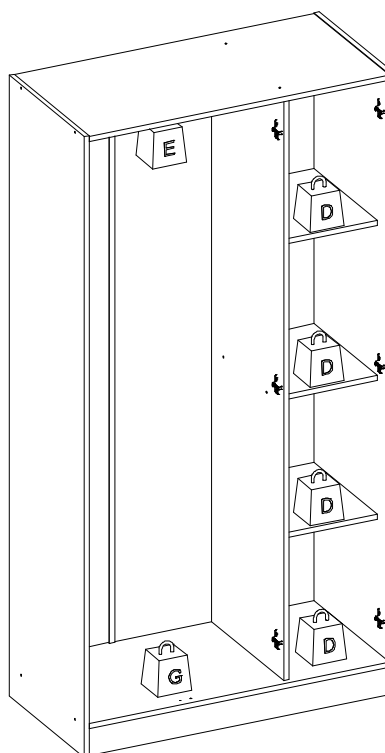

Nº	Measures_Inches	Medidas_cm	Qty./Qtd.
01	35 x 17 1/2 x 5/8	88.8 x 44.5 x 1.5	1
02	11 3/8 x 14 3/4 x 5/8	28.9 x 37.5 x 1.5	2
03	11 3/8 x 14 3/4 x 5/8	28.9 x 37.5 x 1.5	1
04	35 x 17 1/2 x 5/8	88.8 x 44.5 x 1.5	1
05	70 7/8 x 17 1/2 x 5/8	180.0 x 44.5 x 1.5	1
06	66 3/8 x 16 3/4 x 5/8	168.7 x 42.7 x 1.5	1
07	70 7/8 x 17 1/2 x 5/8	180.0 x 44.5 x 1.5	1
08	35 x 3 1/4 x 5/8	88.8 x 8.1 x 1.5	2
09	66 1/8 x 11 1/2 x 5/8	167.9 x 29.1 x 1.5	3
10	67 1/4 x 11 3/4 x 1/8	170.7 x 29.7 x 0.3	2
11	67 1/4 x 12 x 1/8	170.7 x 30.6 x 0.3	1

PARTS IDENTIFICATION
IDENTIFICAÇÃO DAS PEÇAS / IDENTIFICACIÓN DE LAS PIEZAS

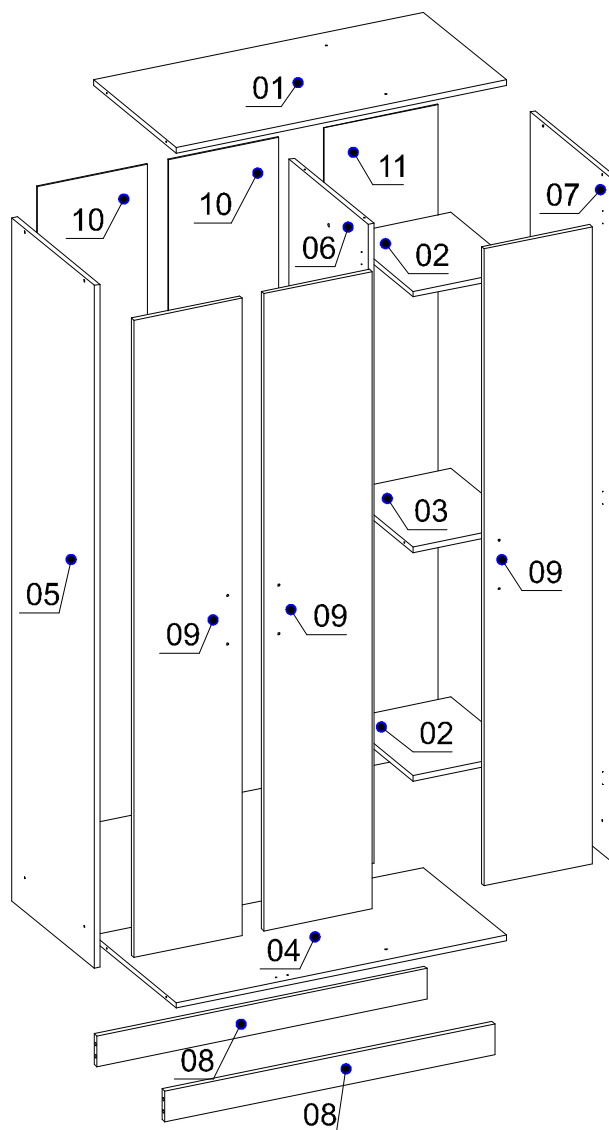

YOU WILL NEED / VOCÊ VAI PRECISAR DE / USTED NECESITARÁ

Tools not supplied / Ferramentas não fornecidas / Herramientas no incluidas

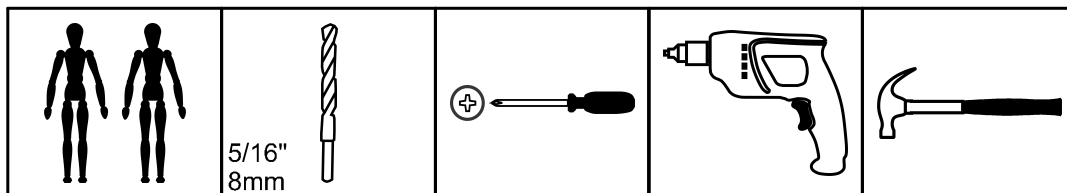

2 People
2 Pessoas
2 Personas

5/16"
8mm
Drill bit
Broca
Taladro

Screwdriver Phillips
Chave Phillips
Destornillador cruz

Drill machine
Furadeira
Taladro

Hammer
Martelo
Martillo











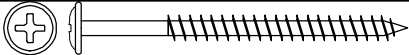











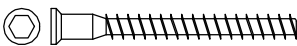

The separation of the accessories before you start the assembly will facilitate the same. In case of doubt on the size of the screws and bolts, use the ruler to bottom of page 3.

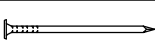
A separação dos acessórios antes de iniciar a montagem facilitará a mesma. Em caso de dúvida no tamanho dos parafusos e cavilhas, utilize a régua ao final da página 3.

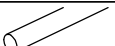
La separación de los accesorios antes de comenzar el armado facilitará el mismo. En caso de duda sobre el tamaño de los tornillos y taquetes, utilice la regla al pie de página 3.

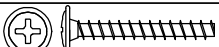
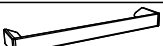
IDENTIFICATION OF ACCESSORIES IDENTIFICAÇÃO DOS ACESSÓRIOS/ IDENTIFICACIÓN DE ACCESORIOS

A		Flanged head screw / Parafuso flangeado / Tornillo de cabeza flangeada	5,0x60 mm	2
A2		Small plastic foot / Sapata redonda / Pie plástico	14 mm	4
A4		Metalic bracket / Cantoneira de metal / Suporte de metal	22x22 mm	1
A6		"H" profile / Perfil "H" / Perfil "H"	-	1
B3		Bushing / Bucha expansiva / Tapón	8x50 mm	2
B8		Shelf bracket / Suporte de prateleira / Suporte de repisa	10x15 mm	4
C1		Metal claw / Garra de metal / Garra metal	-	8
D5		Hinge shim / Calço dobradiça / Bisagra de calce	-	9
D6		Metal hinge super high / Dobradiça super alta / Bisagra alta	26 mm	6
E		Wooden dowel / Cavilha / Taquete	8x30 mm	8
E9		Strap / Cinta / Correa	-	2
F6		Metal hinge curve / Dobradiça curva / Esquina de bisagra metálica	26 mm	3
G		Structural screw / Parafuso estrutural / Tornillo estructural	5,0x50 mm	16
H		Allen key / Chave allen / Liave allen	3 mm	1
H8		Shelf bracket / Suporte de prateleira / Suporte de repisa	6x8 mm	8
I		Structural screw cover/Tampa parafuso estrutural/Tapa tornillo estructural	-	12
N		Nail / Prego / Clavo	10x10	68
P5		Flat head screw / Parafuso chato especial / Tornillo de cabeza plana	3,5x14 mm	2
R4		Laminated plump / Roliço plastificado / Regordete laminado	22 mm	1
S		Pan head screw / Parafuso panela / Tornillo de pan	3,5x14 mm	44
T		Flanged head screw / Parafuso flangeado / Tornillo de cabeza flangeada	3,5x25 mm	6
T12		Handle / Puxador Aleno Fit / Tirador	128 mm	3
Z4		Clothes rack support / Suporte cabideiro / Soporte perchero	-	2



PRE-ASSEMBLE
PRÉ-MONTAGEM / PRE ARMADO

01

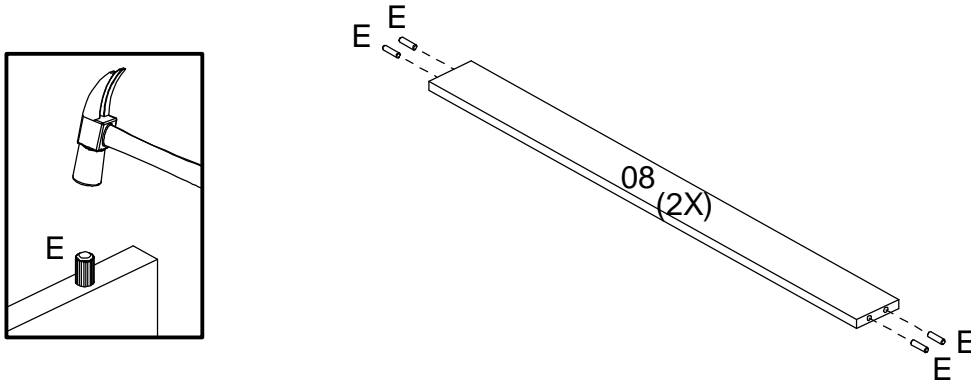

02

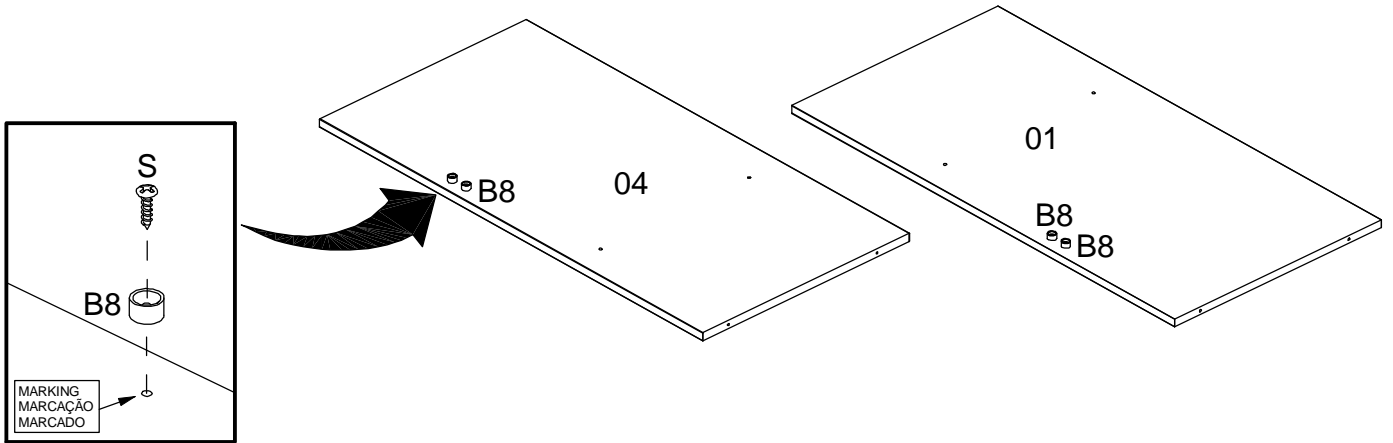

03

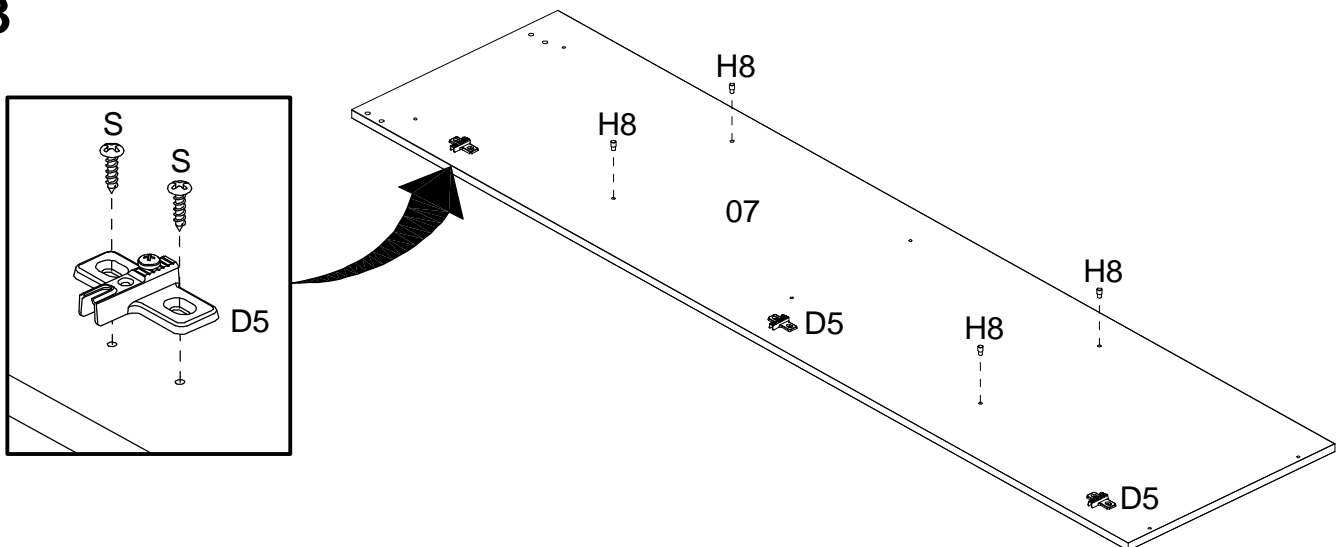

04

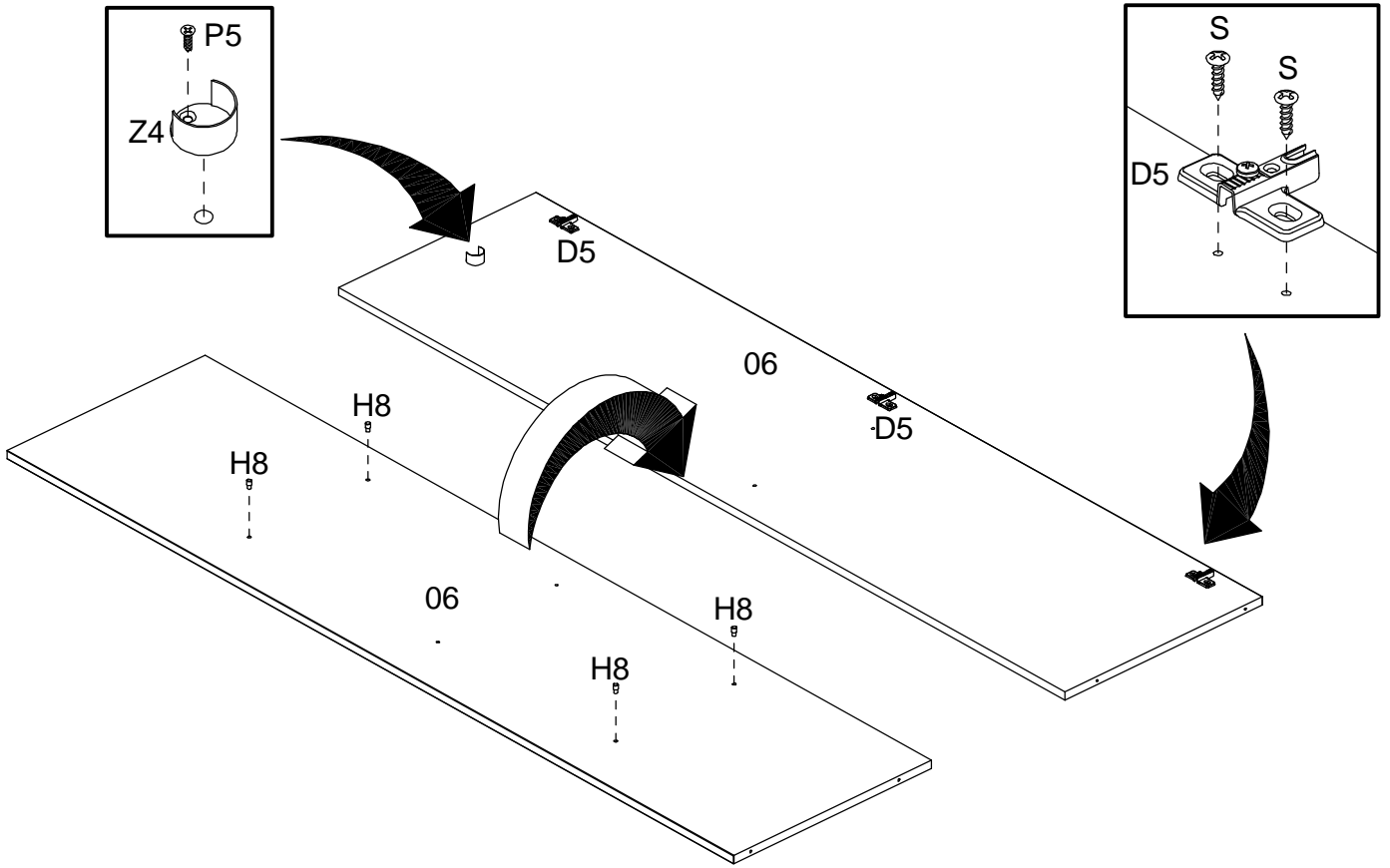

05

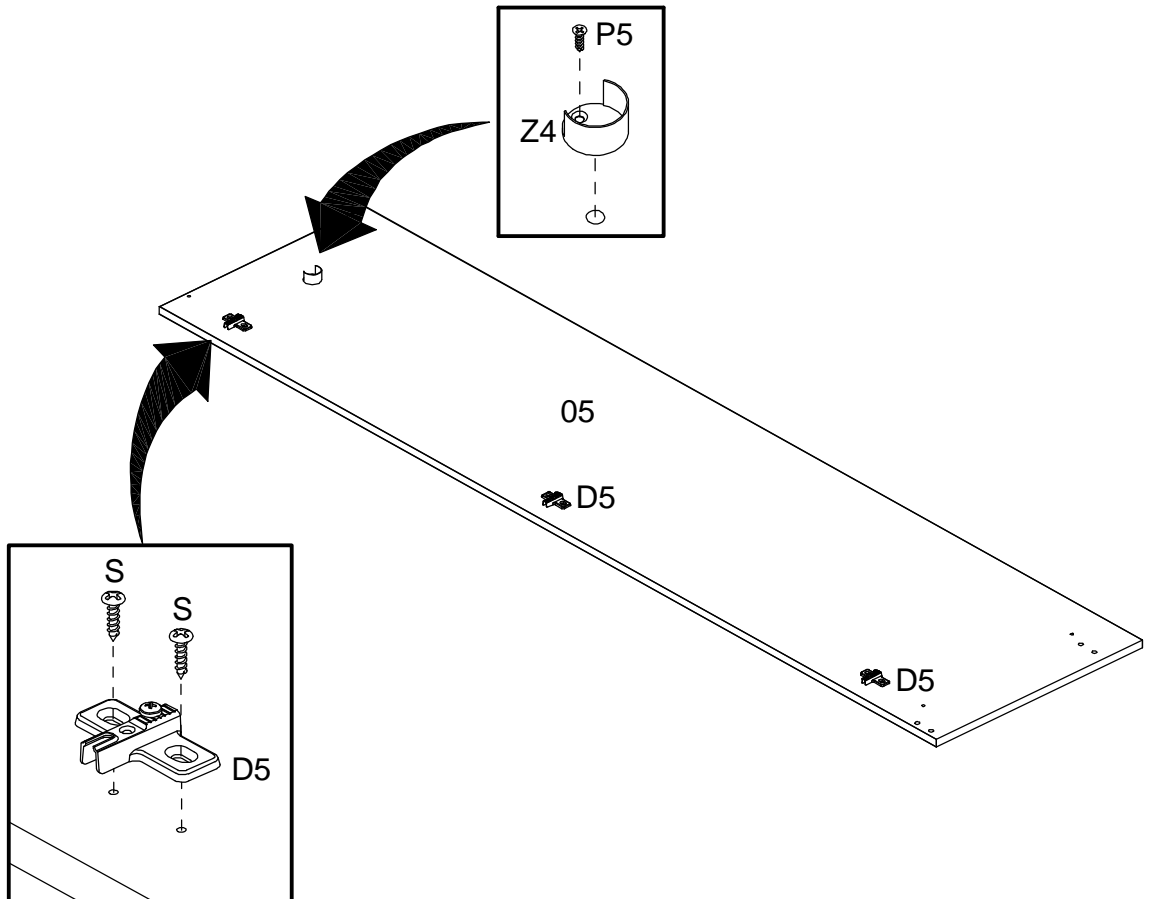

06

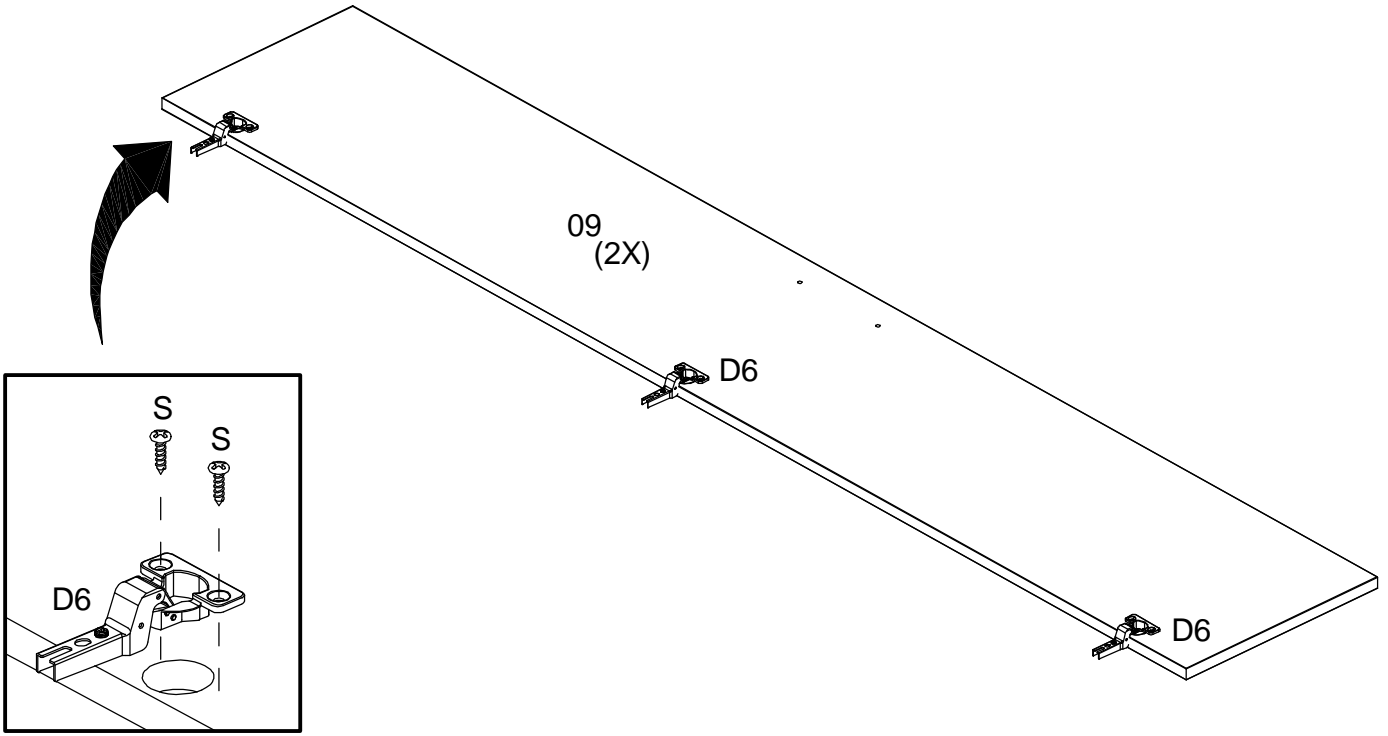

07

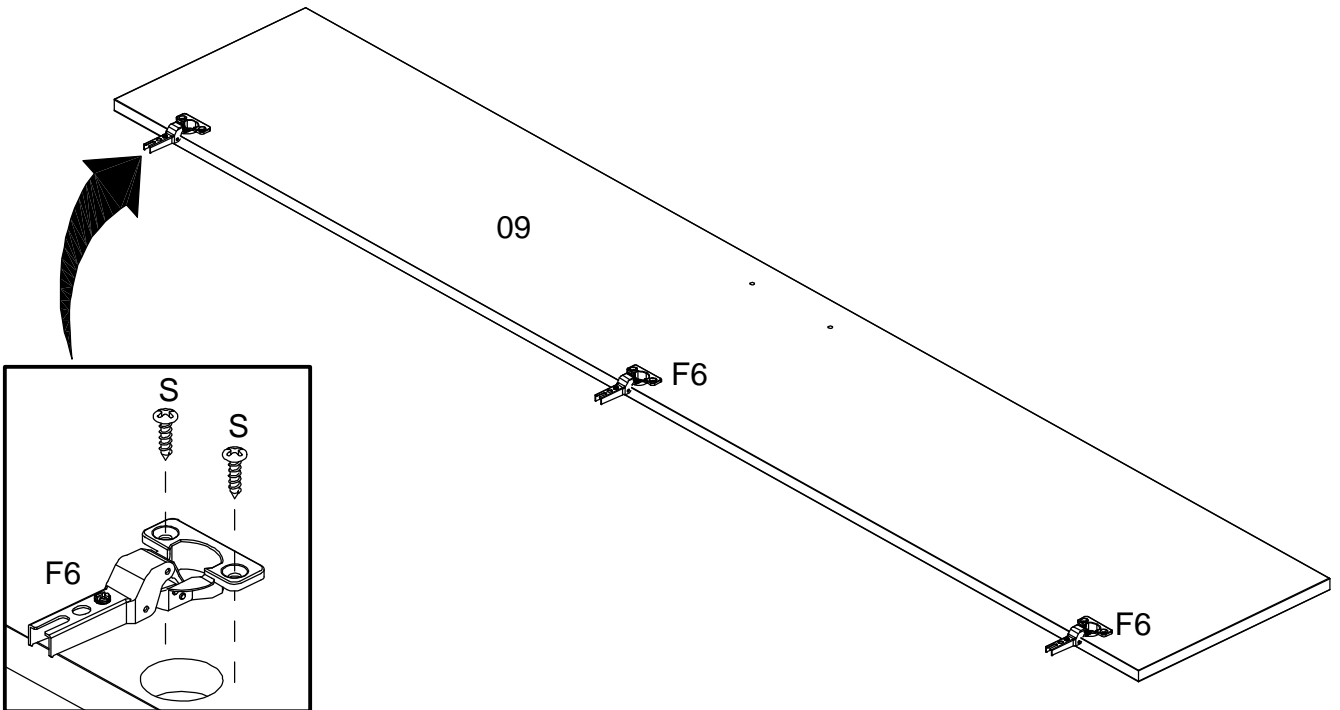

ASSEMBLY
MONTAGEM / ARMADO

08

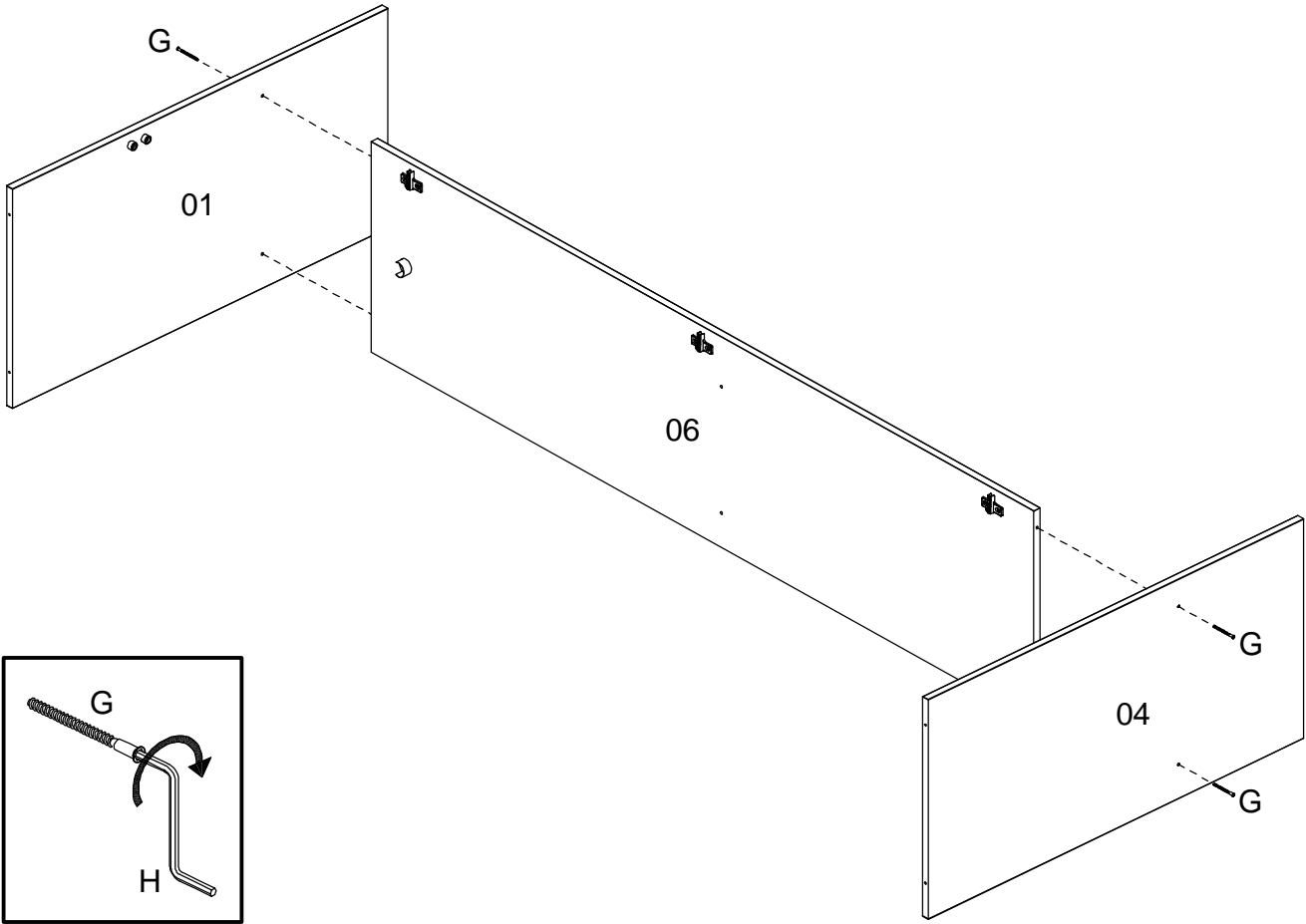

09

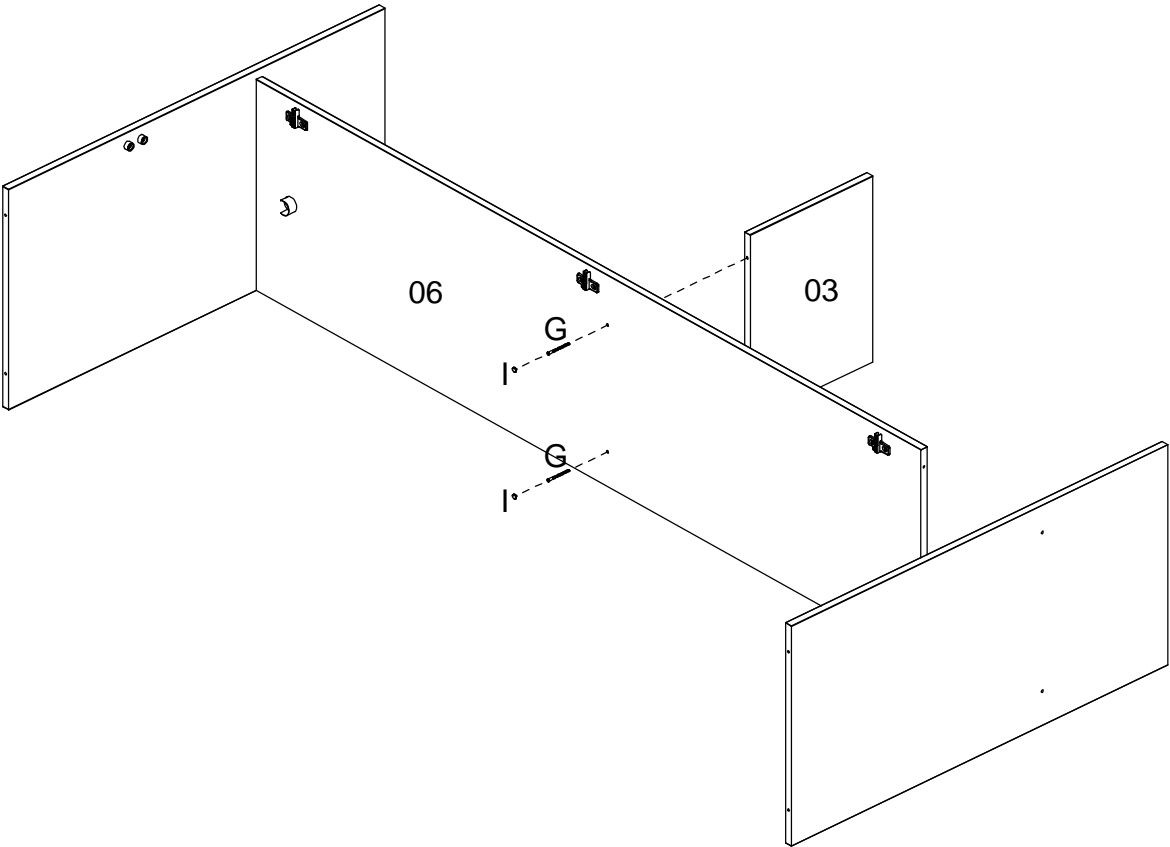

10

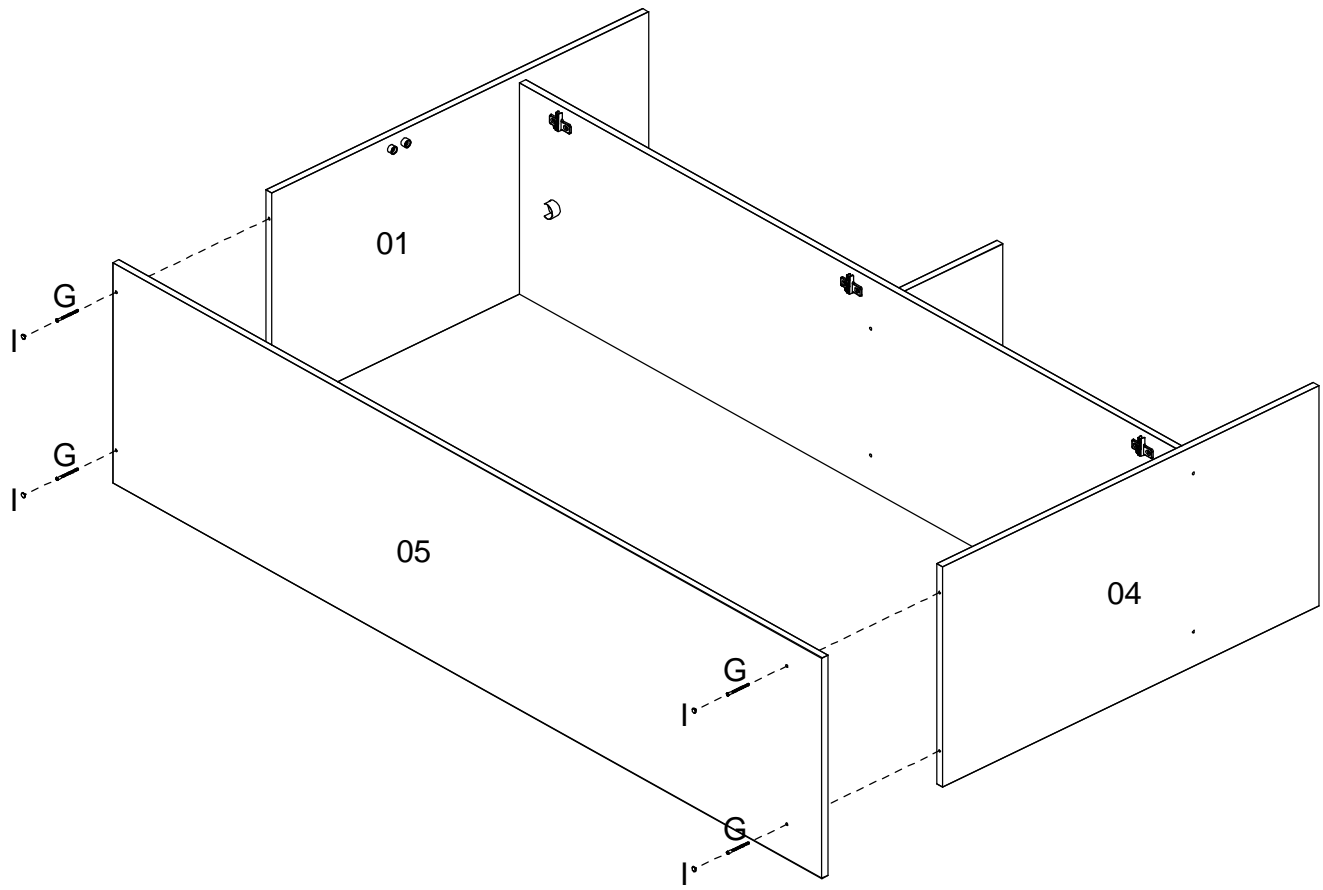

11

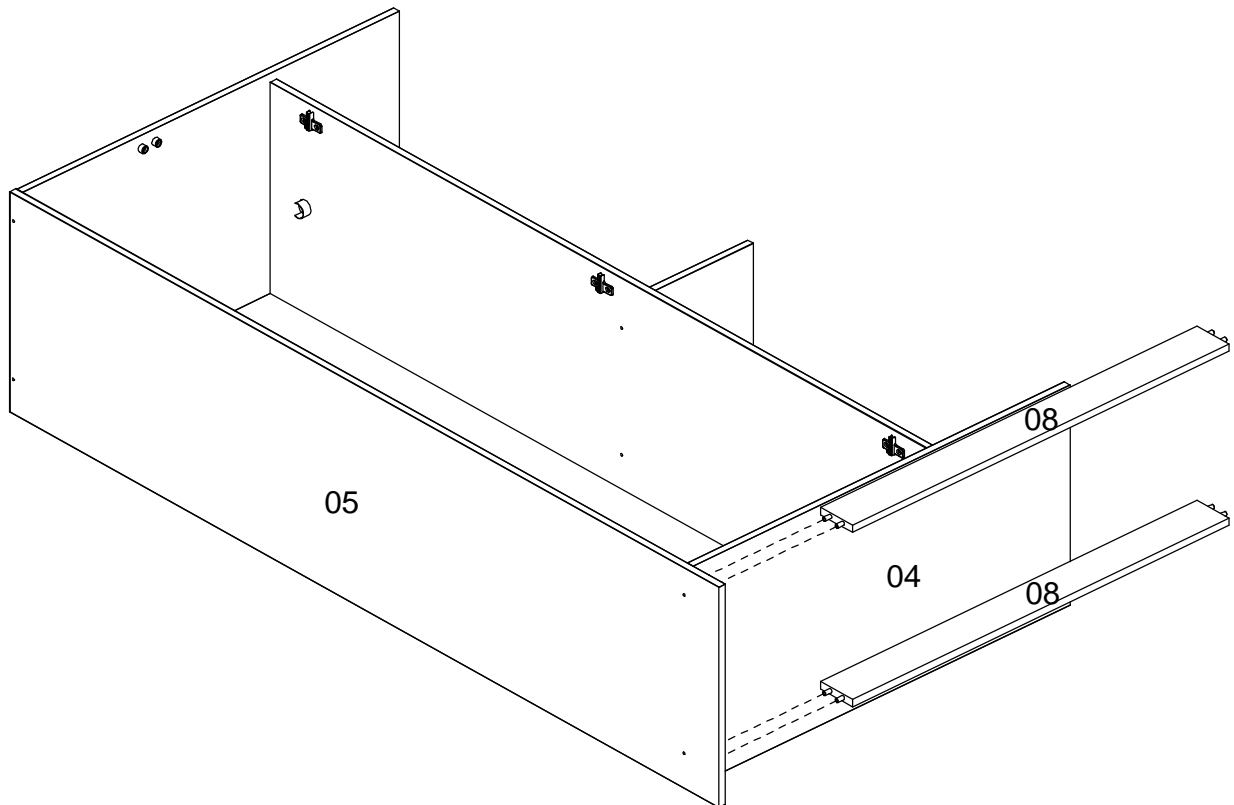

12

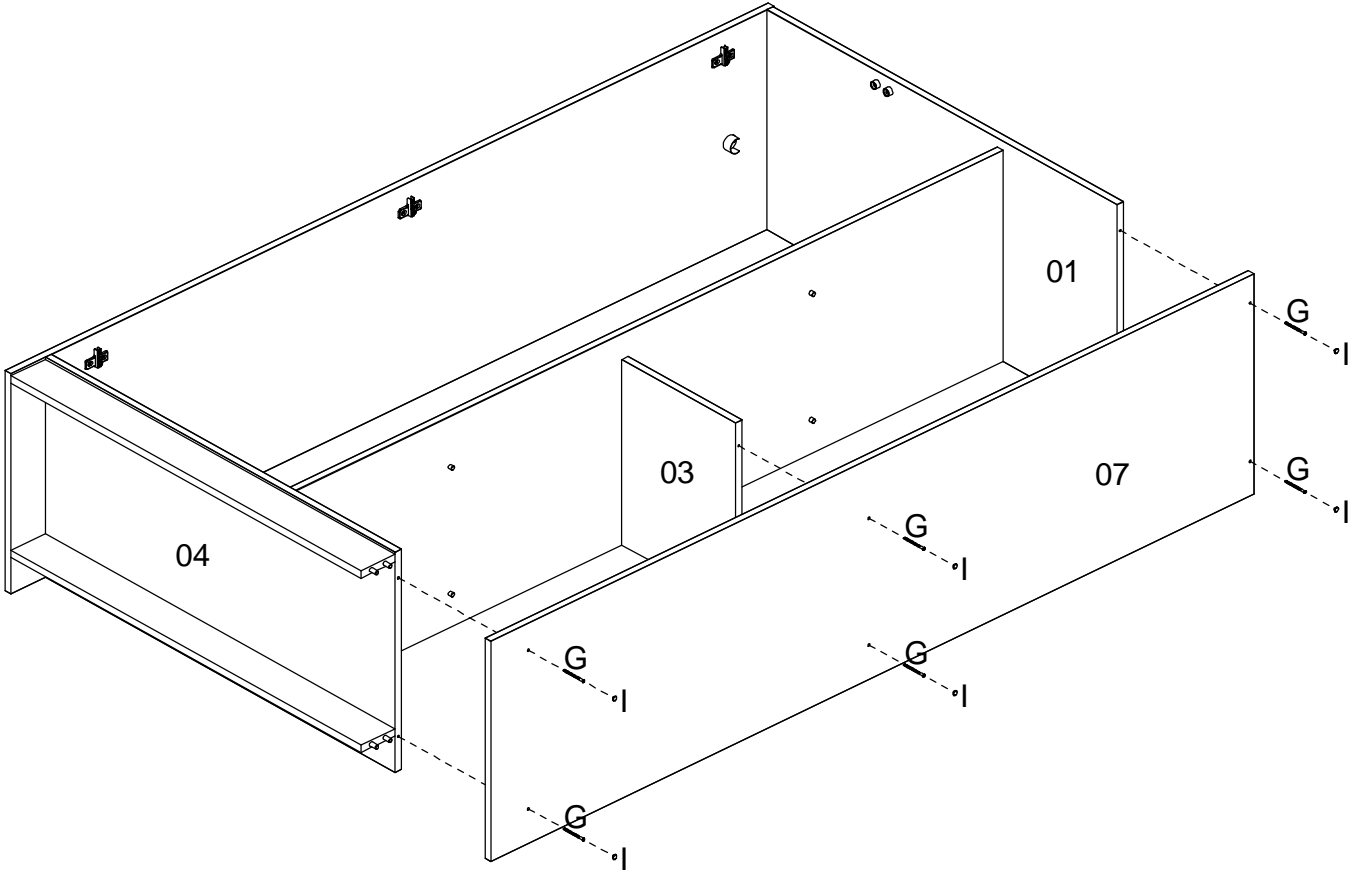

13

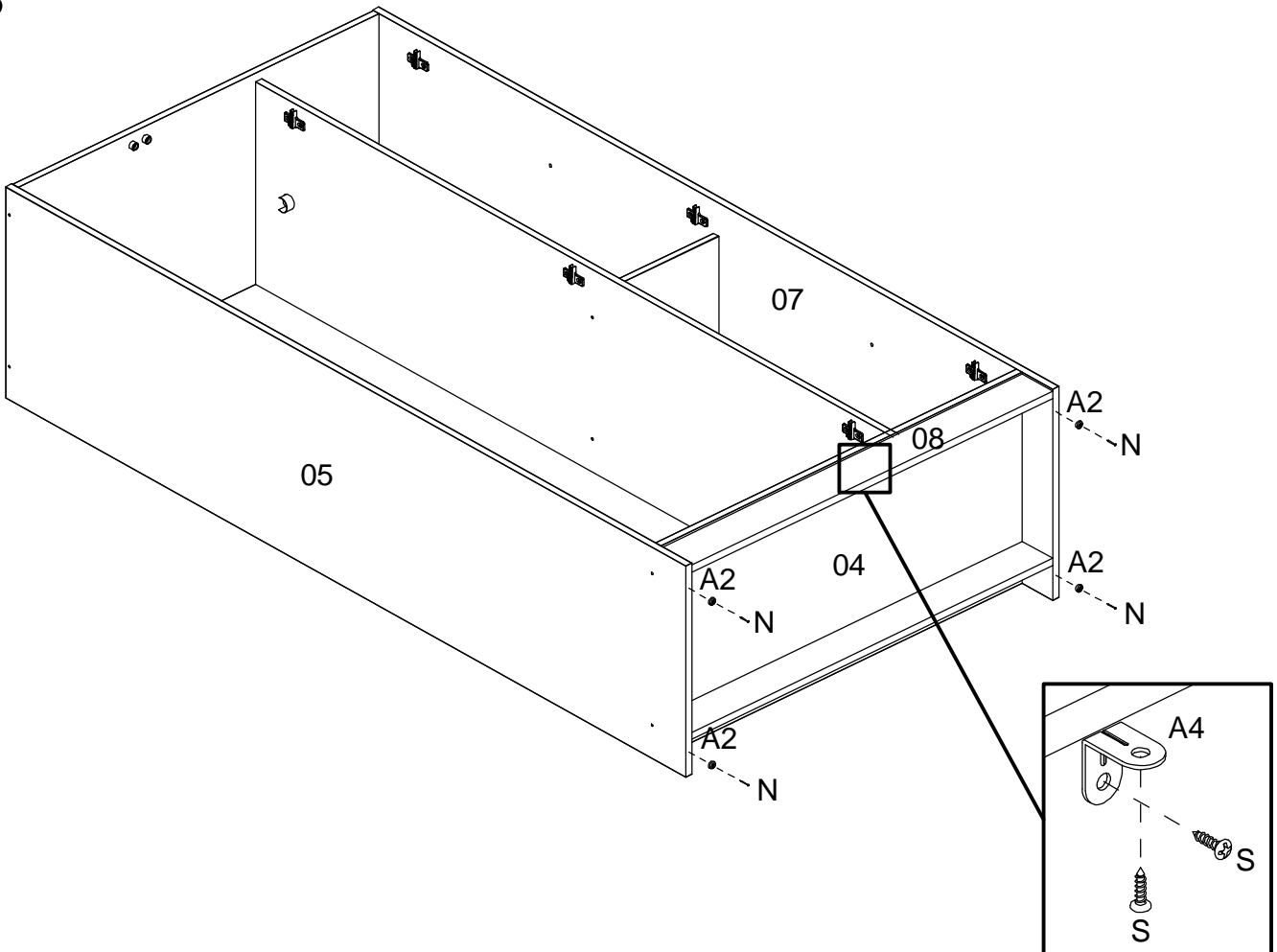

14

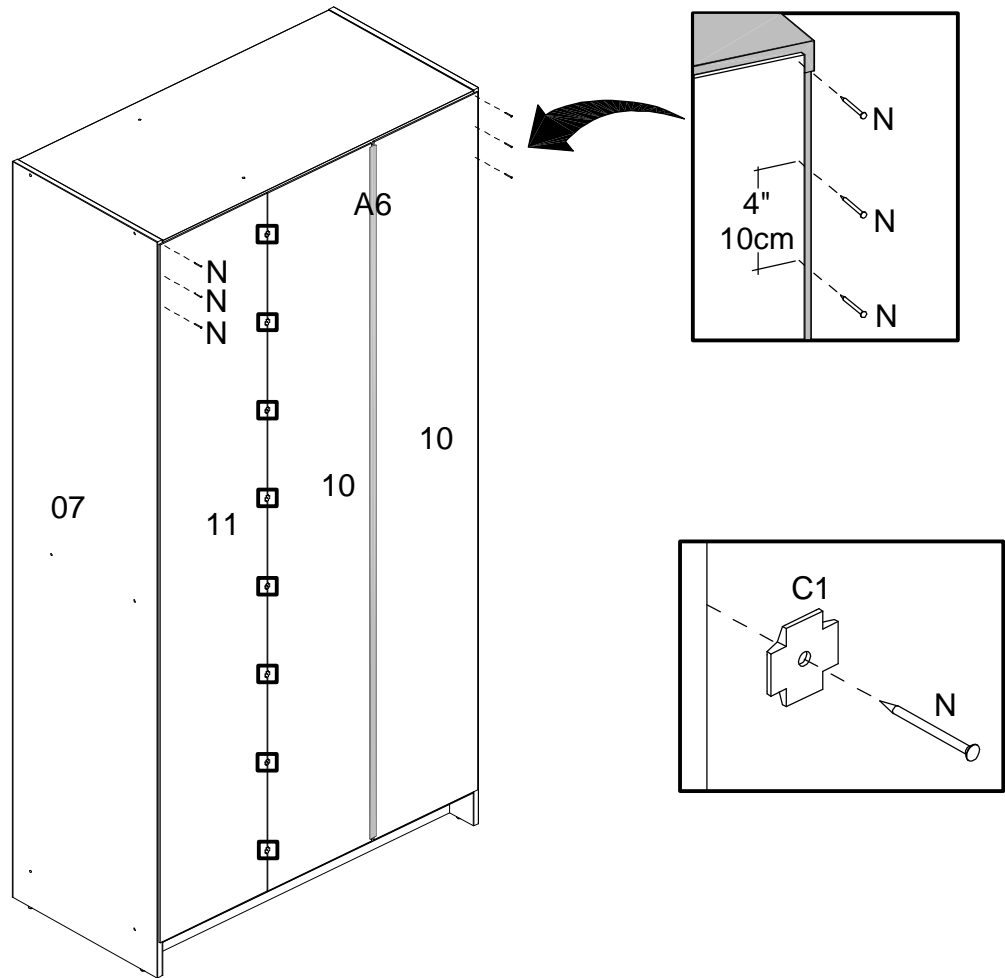

15

TO AVOID ANY INJURY THE FURNITURE MUST BE FIXED ON THE WALL. THANKS.
 PARA EVITAR QUALQUER ACIDENTE, É OBRIGATÓRIO FIXAR O MÓVEL NA PAREDE. OBRIGADO!
 PARA EVITAR CUALQUIER ACCIDENTE ES OBLIGATORIO ANCLAR EL MUEBLE EN LA PARED. GRACIAS.

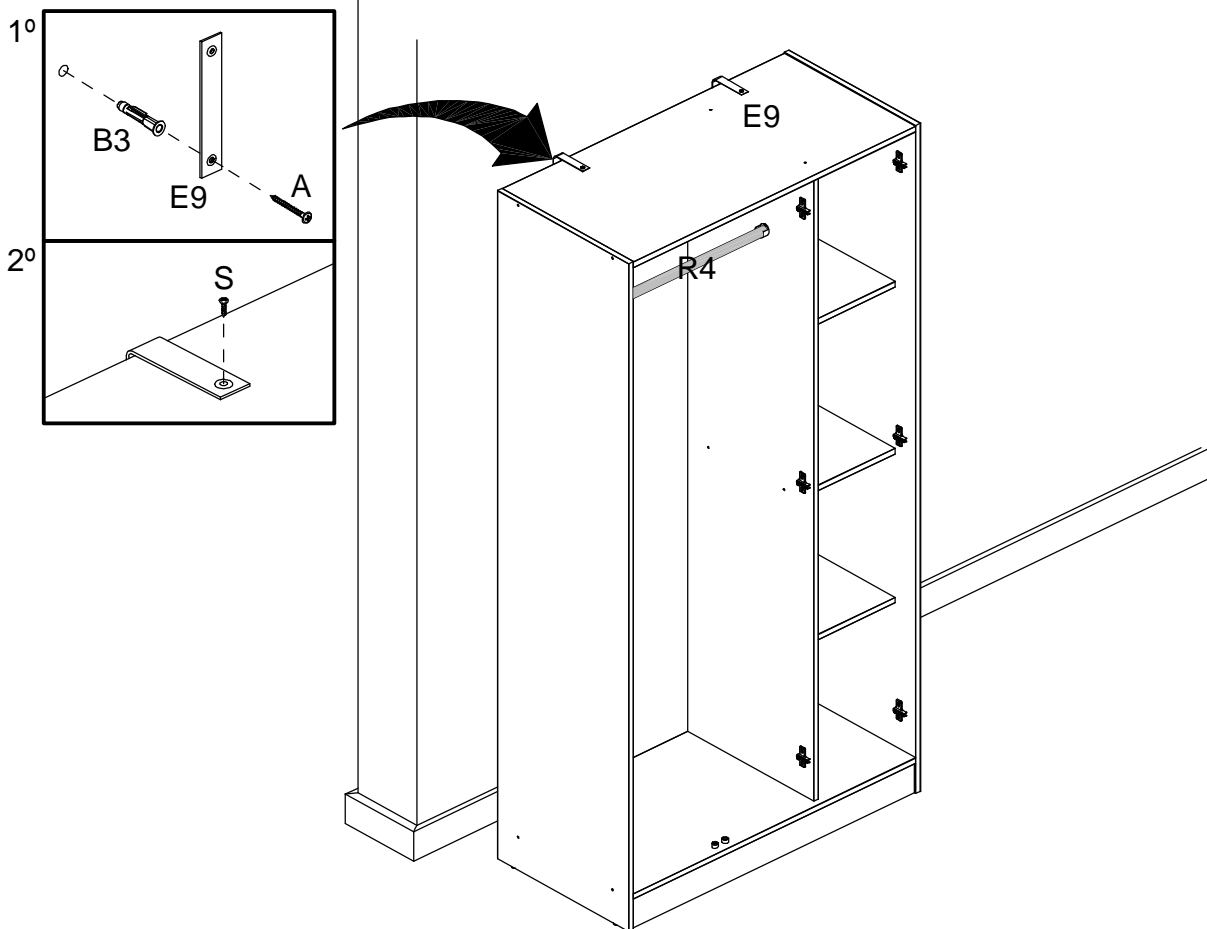

16

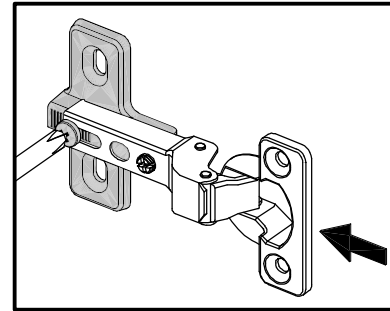
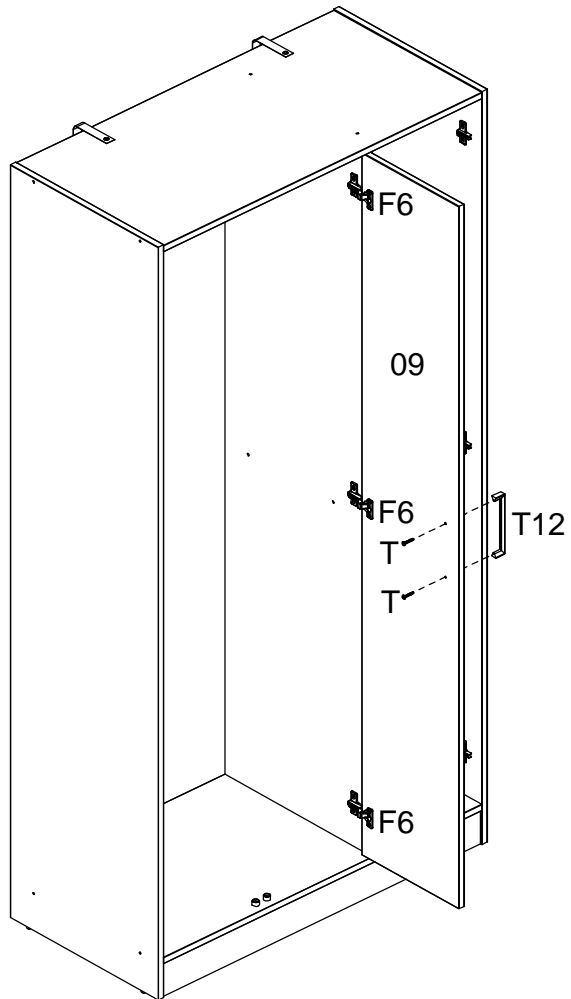

17

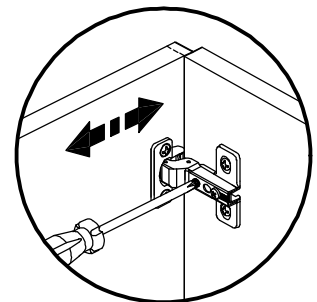
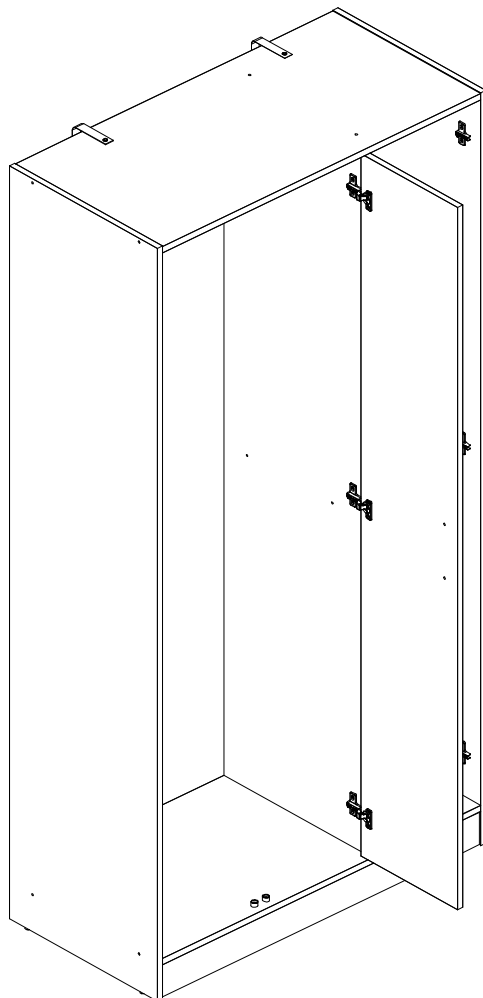

Horizontal Adjustment
Regulagem Horizontal
Ajuste Horizontal

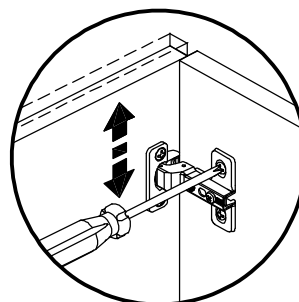

Vertical Adjustment
Regulagem Vertical
Ajuste Vertical

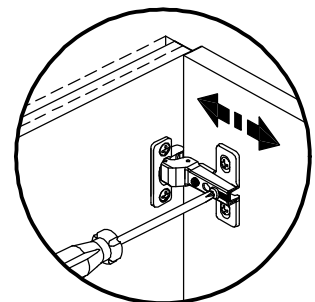

Depth Adjustment
Regulagem Profundidade
Ajuste Profundidad

18

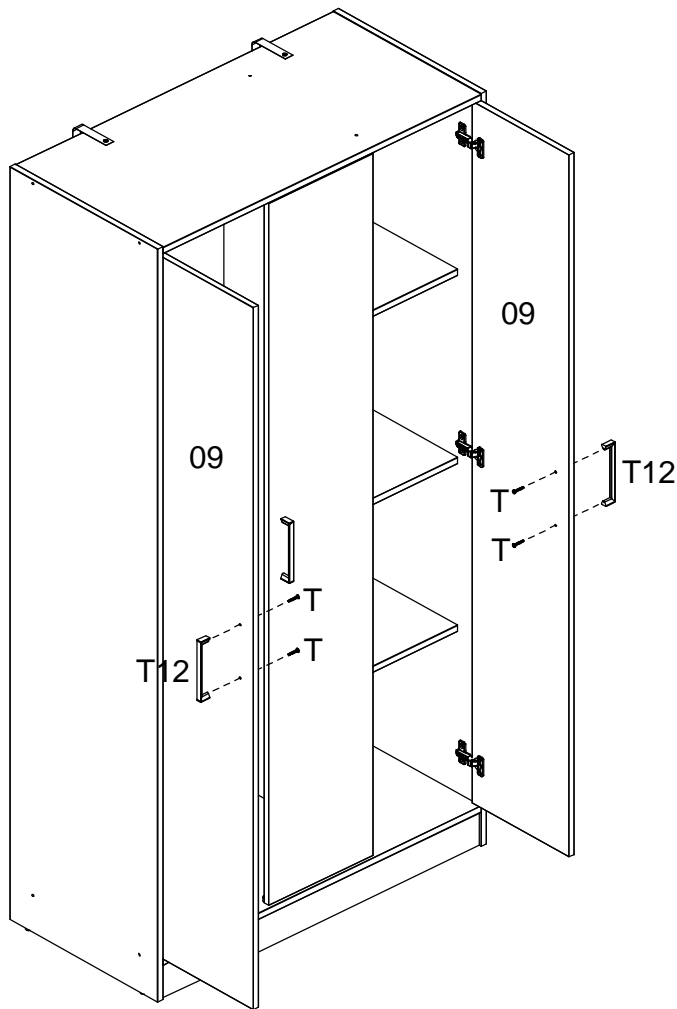

19

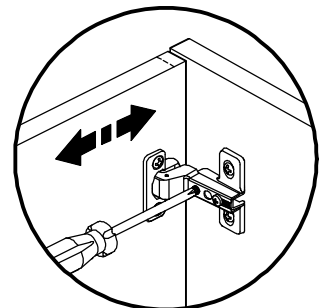
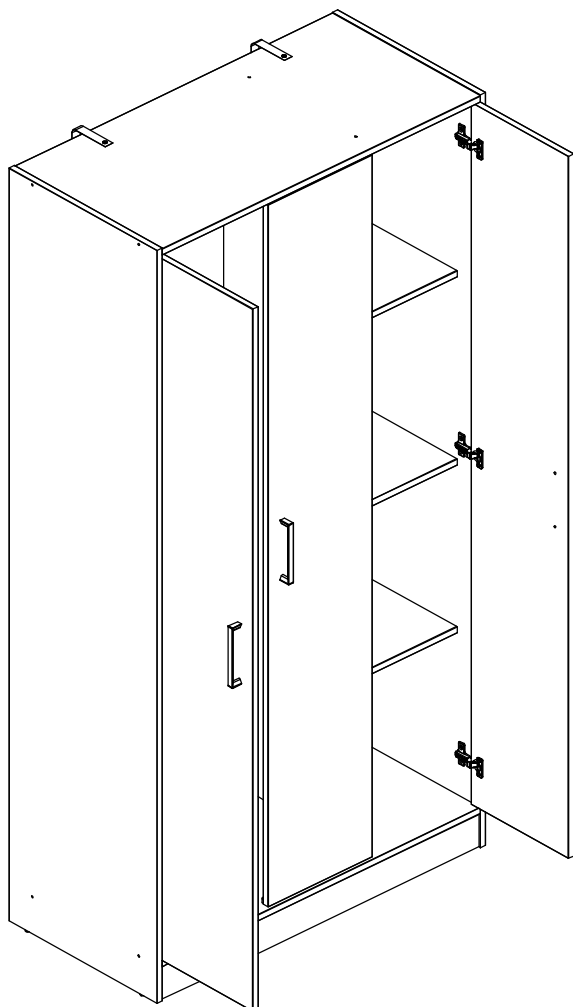

Horizontal Adjustment
Regulagem Horizontal
Ajuste Horizontal

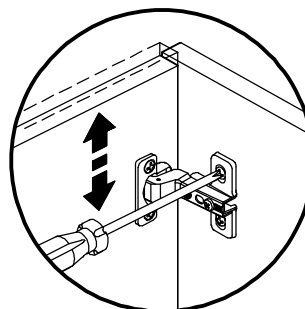

Vertical Adjustment
Regulagem Vertical
Ajuste Vertical

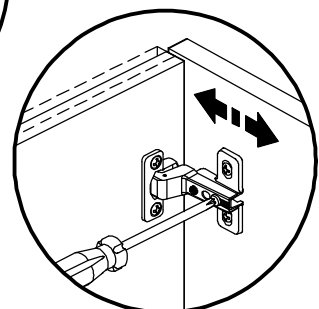

Depth Adjustment
Regulagem Profundidade
Ajuste Profundidad