

boahaus

ASSEMBLY INSTRUCTIONS

ATTENTION!!!

Any inquiry or replacement parts
you need, contact us directly at:

contact@boahaus.com

Scan this QR Code to contact to Customer Support Team.



Or Call Us at +1 (713) 701-5994

boahaus

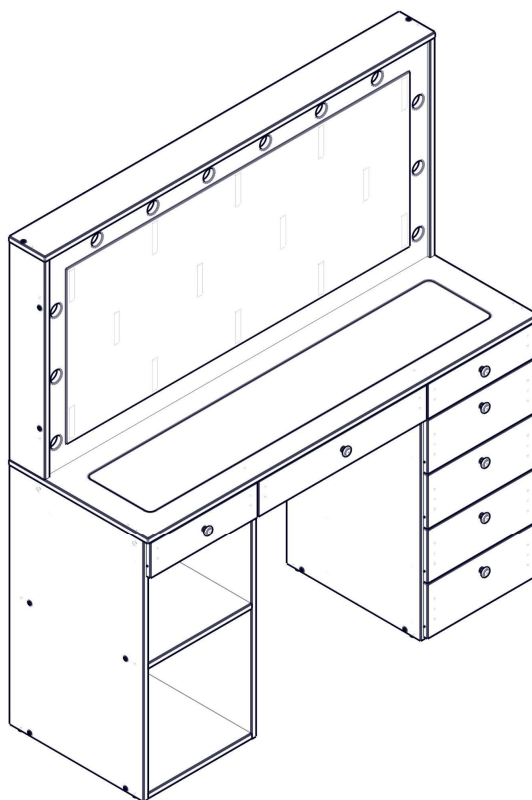
ASSEMBLY INSTRUCTIONS**INSTRUCCIONES DE ARMADO****MODEL #: 1647****DRESSING TABLE WITH MIRROR****Tocador con Espejo****Aprox. product weight 159,50 lbs. / 72,35Kg. *****You can see the ASSEMBLY VIDEO scanning this QR code.****Or enter the following link:**<https://youtu.be/pOrLatP8j3U>

THIS INFORMATION BOOKLET CONTAINS IMPORTANT SAFETY INFORMATION. PLEASE READ AND KEEP FOR FUTURE REFERENCE.
ESTE FOLLETO CONTIENE INFORMACIÓN DE SEGURIDAD IMPORTANTE. POR FAVOR, LEA Y GUÁRDELO PARA REFERENCIA FUTURA.

Need some Help? Call +1 (713) 701-5994 or email contact@boahaus.com
¿Necesitas ayuda? Llama +1 (713) 701-5994 o envía un email contact@boahaus.com

GENERAL SAFETY INFORMATION

1. Please read the Assembly Instructions prior to assembling this product.
2. Remove all the hardware from the box and sort by type.
3. Check to see that all the hardware and parts are present BEFORE assembling.
4. To avoid damage, assemble the product on a sturdy, level, and protective surface.
5. Please wait until all steps are completed before fully tightening bolts.
6. Make sure all bolts are tightly fastened before the unit is used.
7. To move the product, you must lift it. DO NOT drag it, if you drag it can cause overturning.
8. **This product is sold with a hardware kit to be fixed on the wall. You must install this kit to prevent any accidents or damages. When properly installed, this restrain can provide protection against the unexpected tipping of the unit due to small tremors, bumps or climbing. The restrain is only a deterrent and is not a substitute for proper adult supervision. Use of tip-over restraints may only reduce, but not eliminate, the risk of tip-over**

INFORMACIÓN GENERAL DE SEGURIDAD

1. Lea las instrucciones de armado antes de ensamblar este producto.
2. Extraiga todo el hardware de la caja y ordene por tipo.
3. Verifique que todo el hardware y las piezas están presentes ANTES de ensamblar.
4. Para evitar daños, ensamble el producto sobre una superficie resistente, nivelada y con protección.
5. Espere hasta que todos los pasos se hayan completado antes de apretar completamente los tornillos y accesorios.
6. Asegúrese de que todos los tornillos y accesorios estén bien apretados antes de usar la unidad.
7. Para mover el producto debe levantarlo. NO lo arrastre, si lo arrastra puede causar volcamiento.
8. **Este producto se vende con un kit de accesorios para ser fijado en la pared. Debe instalar este kit para evitar accidentes o daños. Cuando se instala correctamente, esta restricción puede proporcionar protección contra la inclinación inesperada de la unidad debido a temblores pequeños, golpes o al treparse. La restricción es solo un elemento disuasivo y no es un sustituto de la supervisión adecuada de un adulto. El uso de restricciones de vuelco solo puede reducir, pero no eliminar, el riesgo de volcarse.**



Maximum weight supported
Peso máximo soportado

General Dimensions / Dimensiones Ge

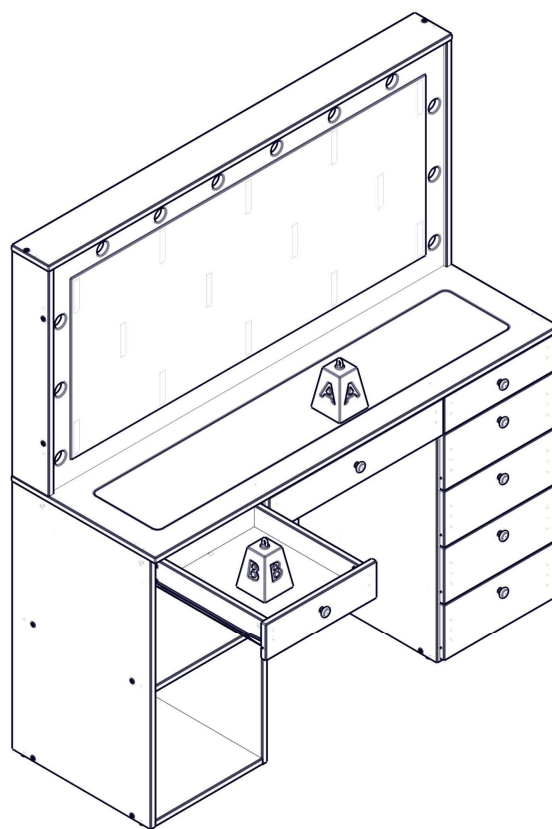
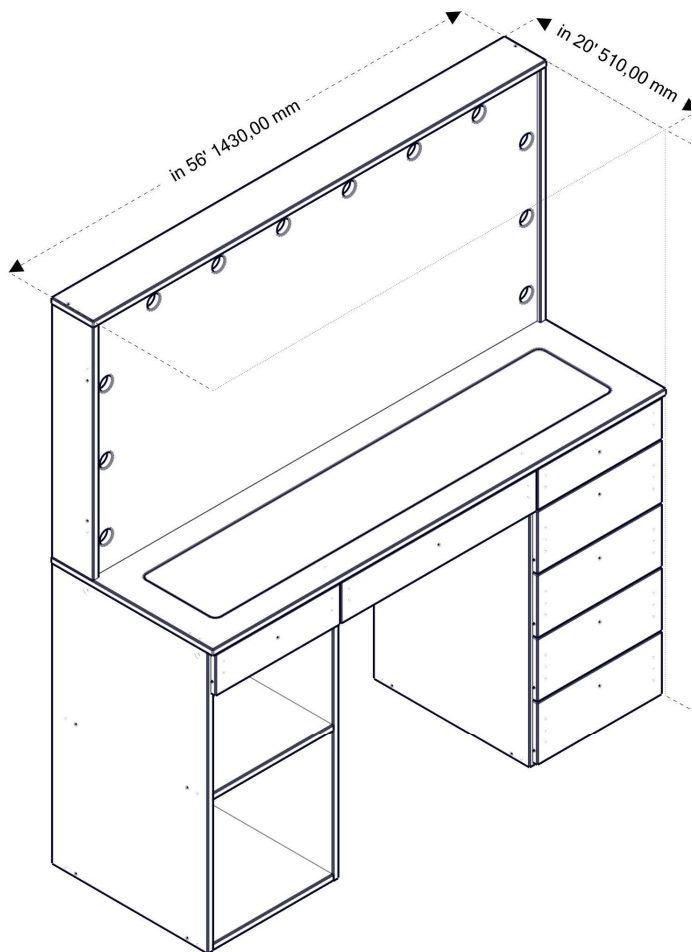

Weight in pounds. / Peso en libras.

Note: weight must be evenly distributed.

Nota: el peso debe do uniformemente.

	KG	LB
A	20	44
B	3	6.6

You will need / usted necesitará:

Tools not included / herramientas no incluidas



2 people

2 personas

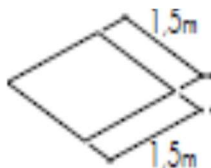

Recommended space for assemble
Espacio recomendado para el armado

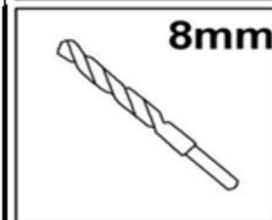
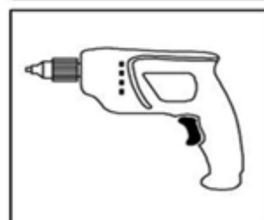
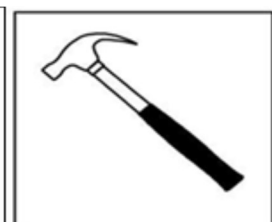
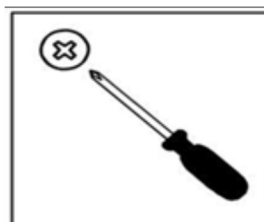







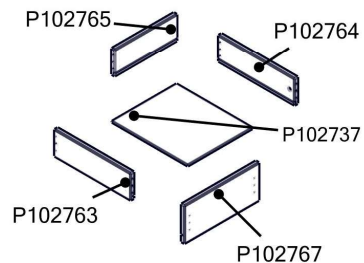
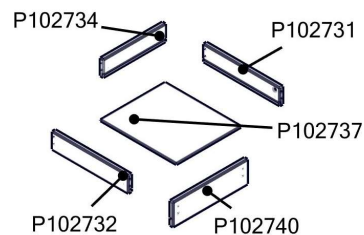
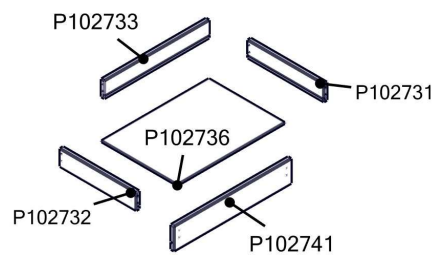
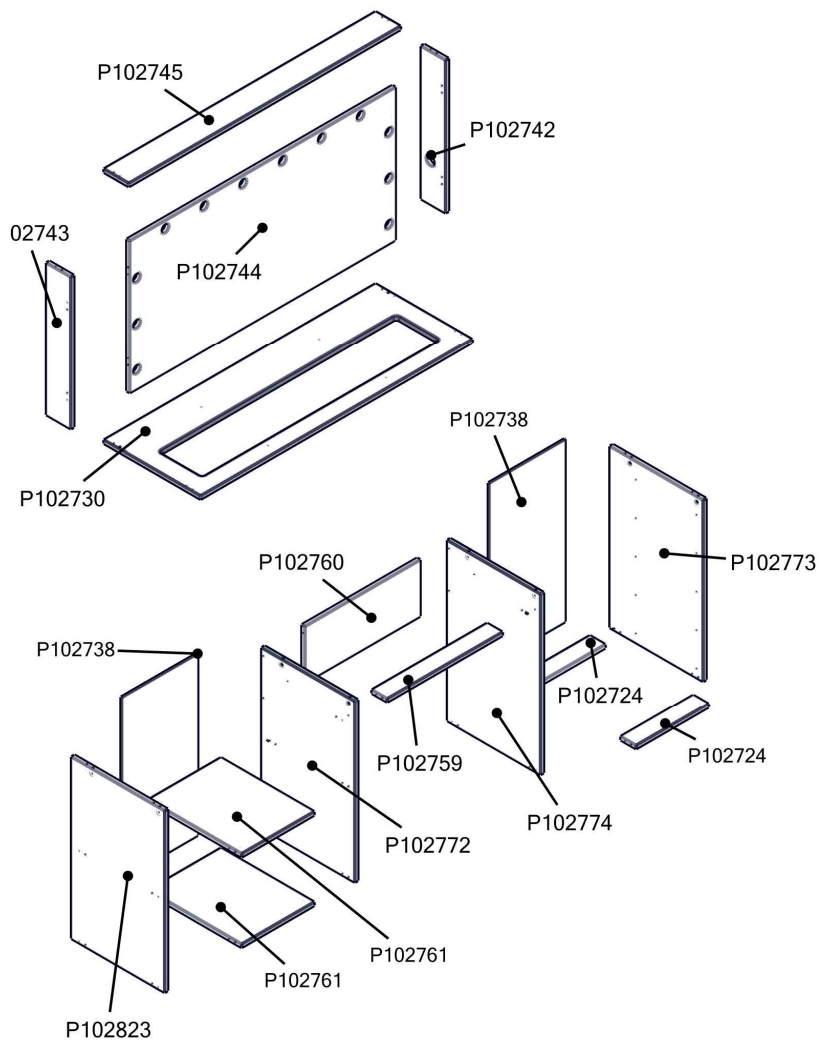

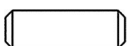
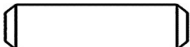

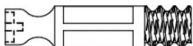







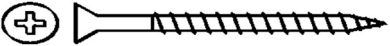
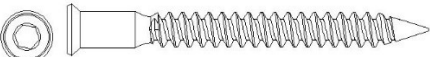
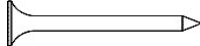

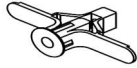
Note: Place a carpet or blanket in the assembly area to avoid damage to the parts during the process.
Nota: Colocar una alfombra o manta en el area de armado para evitar daños en las piezas durante el proceso.

Need some Help? Call +1 (713) 701-5994 or email contact@boahaus.com
¿Necesitas ayuda? Llama +1 (713) 701-5994 o envía un email contact@boahaus.com

CODE	DESCRIPTION	DESCRICOES (config)	LENGHT(mm)	WIDTH(mm)	THICKNESS(mm)	Amout
P102724	BASEBOARD	ZOCALO	381	80	15	2
P102730	TOP	TAPA	1430	508	15	1
P102731	RIGHT DRAWER SIDE	LADO DERECHO DEL CAJÓN	400	80	15	3
P102732	LEFT DRAWER SIDE	LADO ESQUIERDO DEL CAJÓN	400	80	15	3
P102733	DRAWER HEAD	CABEZAL DEL CAJÓN	551	80	15	1
P102734	DRAWER HEAD	CABEZAL DEL CAJÓN	326	80	15	2
P102736	DRAWER BOTTOM	FONDO DEL CAJÓN	564	398	3	1
P102737	DRAWER BOTTOM	FONDO DEL CAJÓN	339	398	3	6
P102738	COAST	COSTA	830	400	3	2
P102740	DRAWER FRONT	FRENTE DEL CAJÓN	391	111	15	2
P102741	DRAWER FRONT	FRENTE DEL CAJÓN	616	111	15	1
P102742	RIGHT SIDE	LADO DERECHA	695	128	15	1
P102743	LEFT SIDE	LADO ESQUIERDA	695	128	15	1
P102744	COAST	COSTA	1398	695	15	1
P102745	HAT	SOMBRERO	1430	130	15	1
P102759	PLATTER	TRAVESANO	606	80	15	1
P102760	REINFORCEMENT	REFORZAMIENTO	606	256	15	1
P102761	BASE	BASE	381	490	15	2
P102763	LEFT DRAWER SIDE	LADO ESQUIERDO DEL CAJÓN	400	120	15	4
P102764	RIGHT DRAWER SIDE	LADO DERECHO DEL CAJÓN	400	120	15	4
P102765	DRAWER HEAD	CABEZAL DEL CAJÓN	326	120	15	4
P102767	DRAWER FRONT	FRENTE DEL CAJÓN	391	170	15	4
P102772	DIVISION	DIVISION	825	490	15	1
P102773	RIGHT SIDE	LADO DERECHA	825	490	15	1
P102774	DIVISION	DIVISION	825	490	15	1
P102823	LEFT SIDE	LADO IZQUIERDO	825	490	15	1

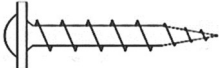
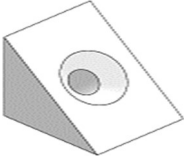
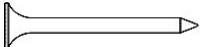

NUMBER		DESCRIPTION	QTY
001802		Wooden dowel / Pin (6 x 30 mm)	66
001925		Wooden dowel / Pin (6 x 50 mm)	2
058788		Allen key / Llave allen	1
030945		Simple minifix screw / Tornillo minifix simple	23
030950		Drum lock / Tambor minifix	23
005288		Metallic left slide 400mm / corredera lateral izquierda 400mm	7
005288		Metallic right slide 400 mm / Corredera lateral derecha 400mm	7
005288		Left drawer slide 400mm / Corredera cajón izquierda 400mm	7
005288		Right drawer slide 400 mm / Corredera cajón derecha 400 mm	7
004214		Flat head screw / Tornillo cabeza plana (3,5 x 14 mm)	72
005256		Flat head screw / Tornillo cabeza plana (4,0 x 20 mm)	15
051980		Screw / Tornillo cabeza plana (4,5 x 50 mm)	2
075515		Structural screw / Tornillo estructural (5 x 40 mm)	41
000107		Nail / Clavo	48
13mm		Adhesive bore patch / Tapón adhesivo	38
032069		Drywall Anchor / Anclaje de pared	2
062448		Handle / Tirador	7
000899		Angle plates / Soporte	4

055606		Mounting bracket / Soporte de montaje	2
001901		Small plastic foot / Pie plástico	9
19mm		Adhesive bore patch / Tapón adhesivo	22
055607		Clamp / Abrazadera	1
001178		Flanged head screw / Tornillo cabeza flangeada (3,5 x 16 mm)	2
018458		Drawer angle plates / Soporte cajón	15
000108		Nail / Clavo (12x12mm)	9
068915		Drawer Organizer / Organizador de cajones	1



ATTENTION

To facilitate the assembly process, separate and organize all boards before you start.

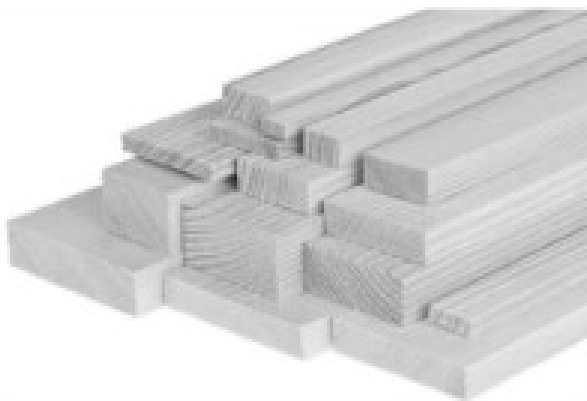

Para facilitar el armado, separa y organiza todas las tablas antes de empezar.

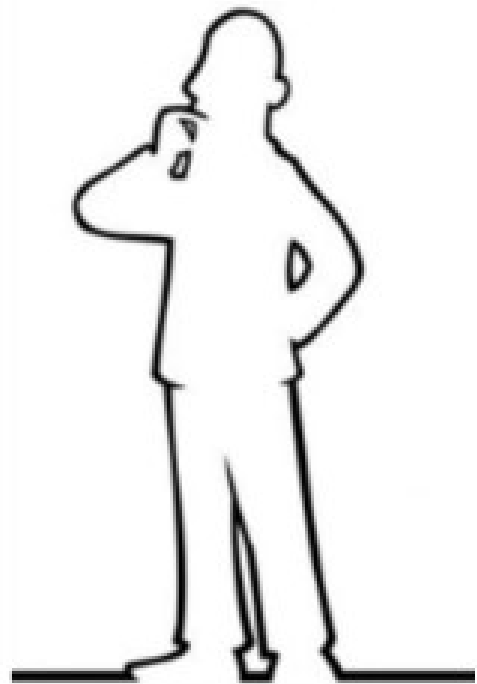

PRE-ASSEMBLY / PRE- ARMADO

1. Fix **wooden dowel** (001802) and **larger wooden dowel** (001925) to **Upper right side** (P102742).
Fijar **pin** (001802) y **pin mayor** (001925) **Parte superior derecha** (P102742).

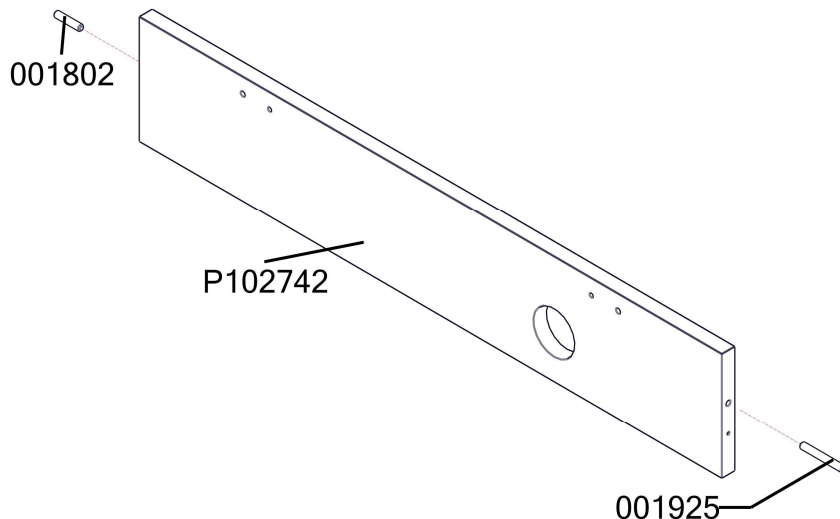

2. Fix **wooden dowel** (001802) and **larger wooden dowel** (001925) to **Upper leftt side** (P102743).
Fijar **pin** (001802) y **pin mayor** (001925) **Parte superior izquierda** (P102743).

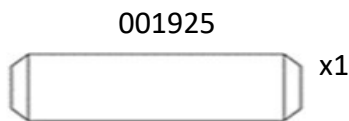
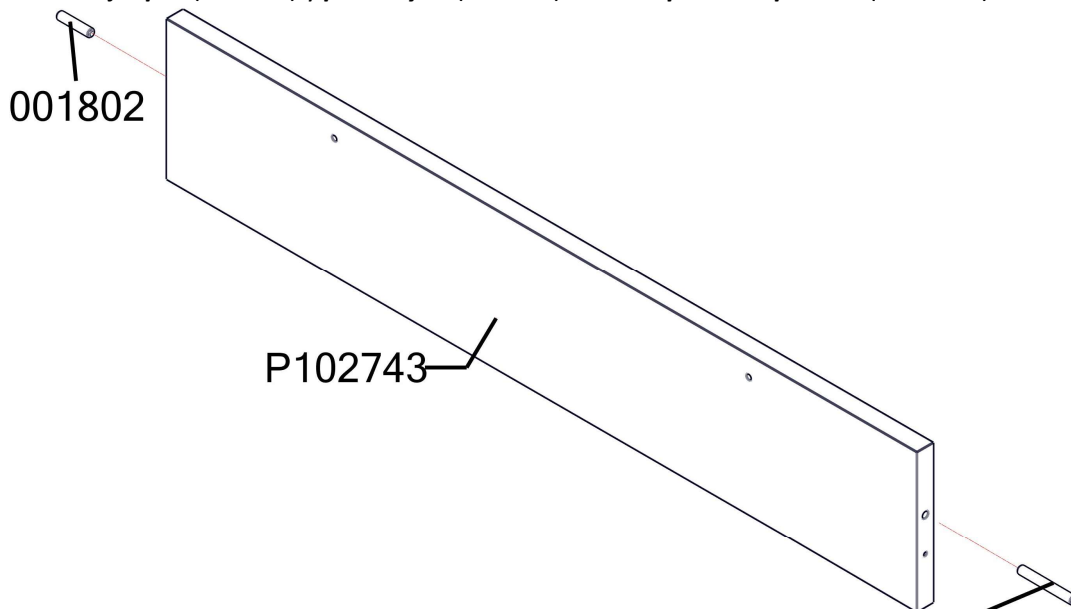

3. Fix **wooden dowel** (001802) to **crossbeam** (P102759).
Fijar **pin** (001802) a **travesaño** (P102759).

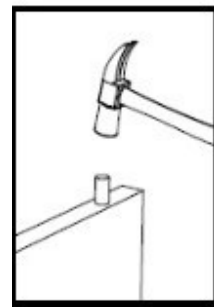
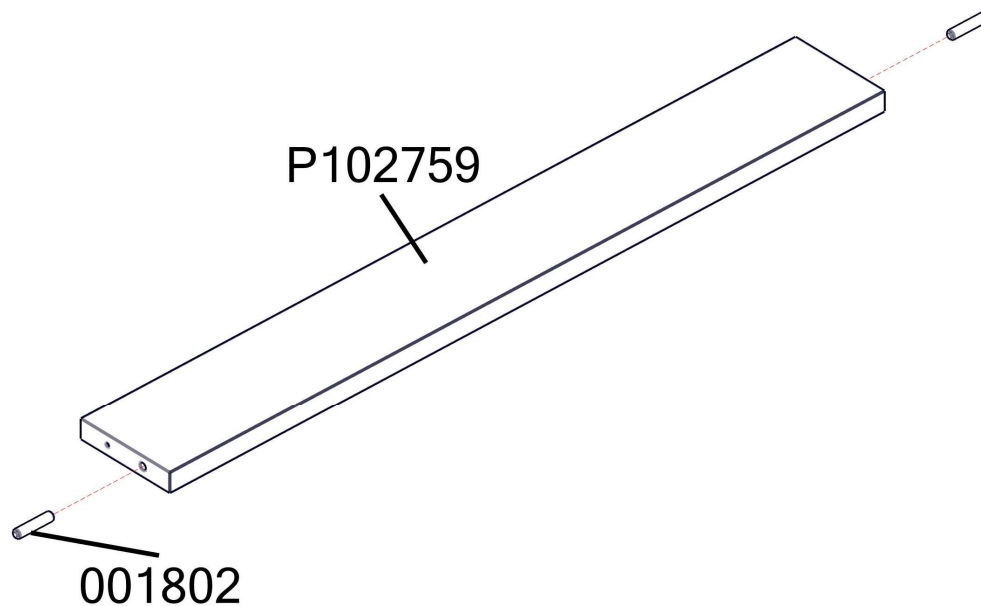

4. Fix **wooden dowel** (001802) and **large footer** (P102724) x2.
Fijar **pin** (001802) y **zócalo grande** (P102724) x2.

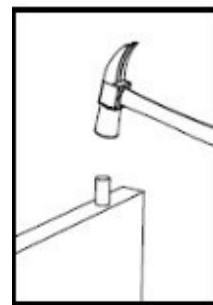
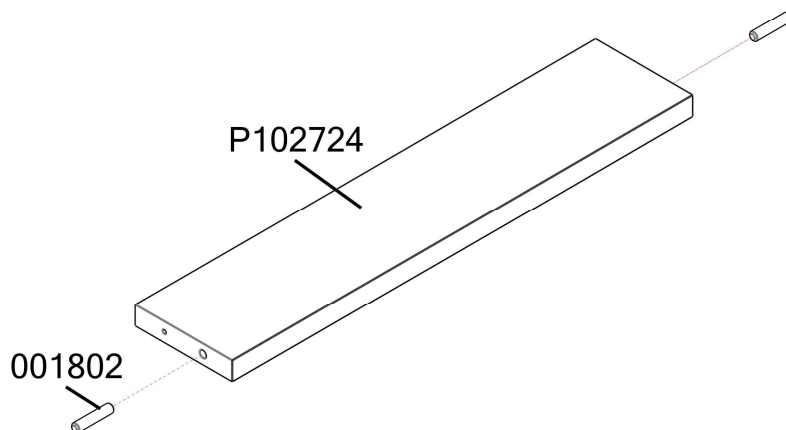

5. Fix **wooden dowel** (001802) to **base** (P102761).
Fijar pin (001802) y base (P102761).

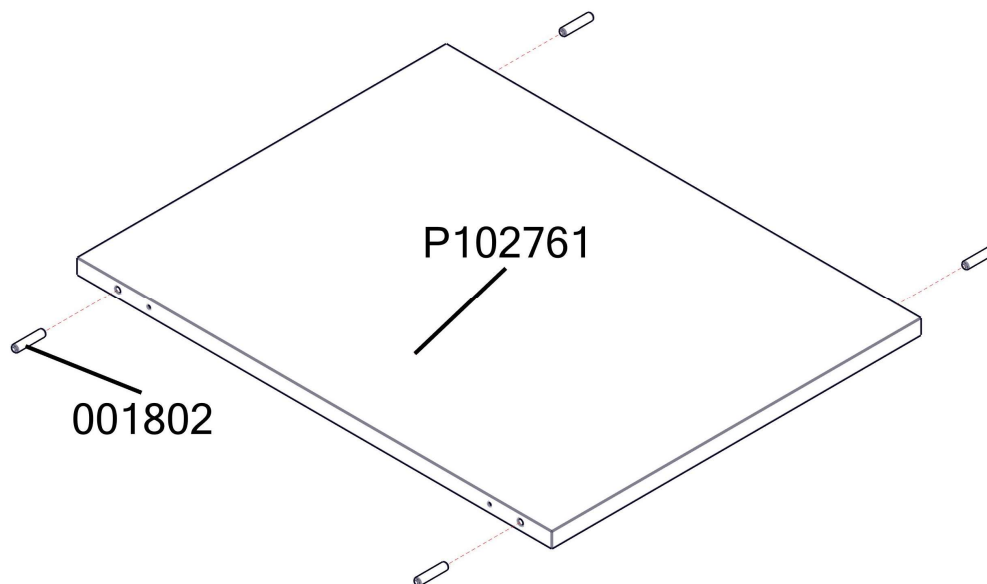

6. Fix **simple minifix screw** (030945) to **top base** (P102730).
Fijar **tornillo minifix simple** (030945) a **base superior** (P102730).

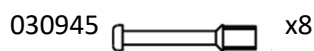
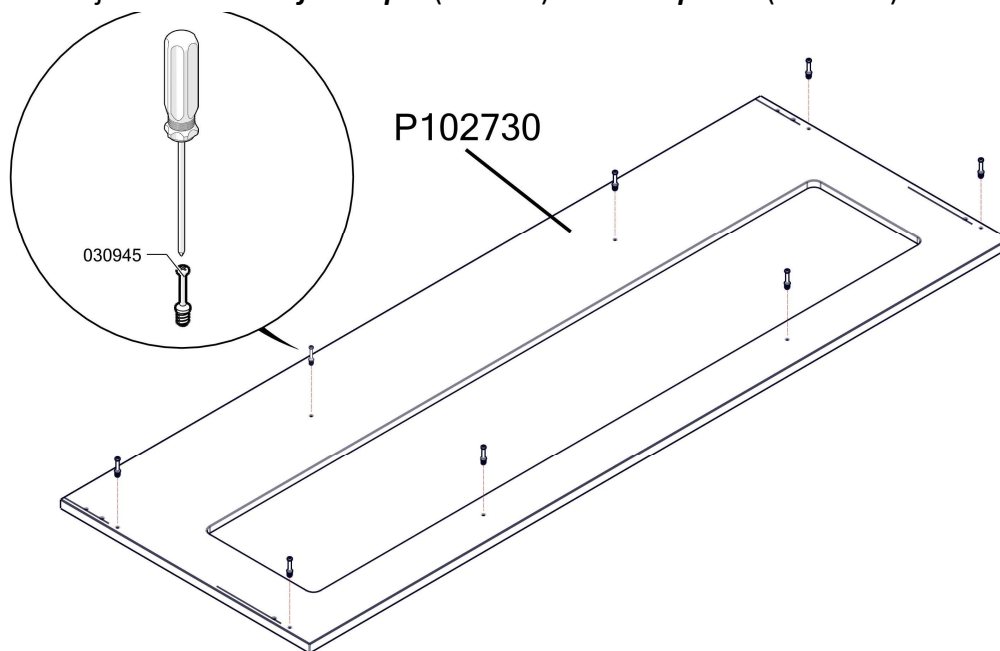

7. Fix **wooden dowel** (001802), **metallic right slide** (005288) and **plastic foot** (001901) to **right side** (P102773).
 Fijar **pin** (001802), **corredera lateral derecha** (005288) y **pie plástico** (001901) a **lateral derecha** (P102773).

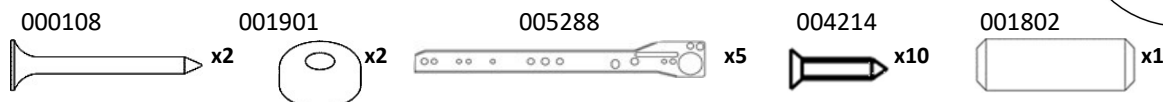
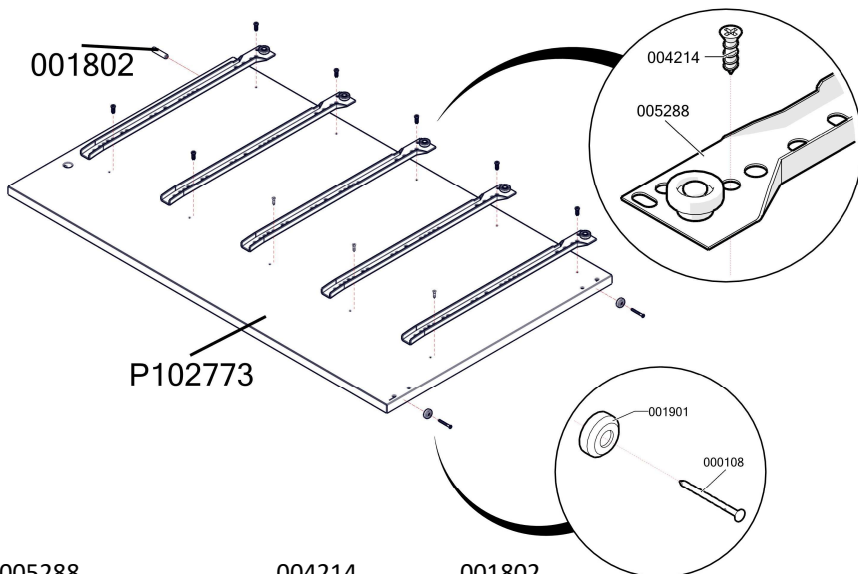

8. Fix **wooden dowel** (001802), **metallic left slide** (005288) and **plastic foot** (001901) to **left side** (P102823).
 Fijar **pin** (001802), **corredera lateral izquierda** (005288) y **pie plástico** (001901) a **lateral izquierda** (P102823).

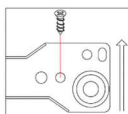
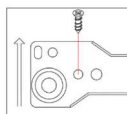
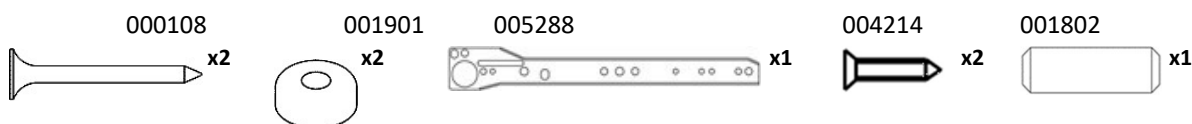
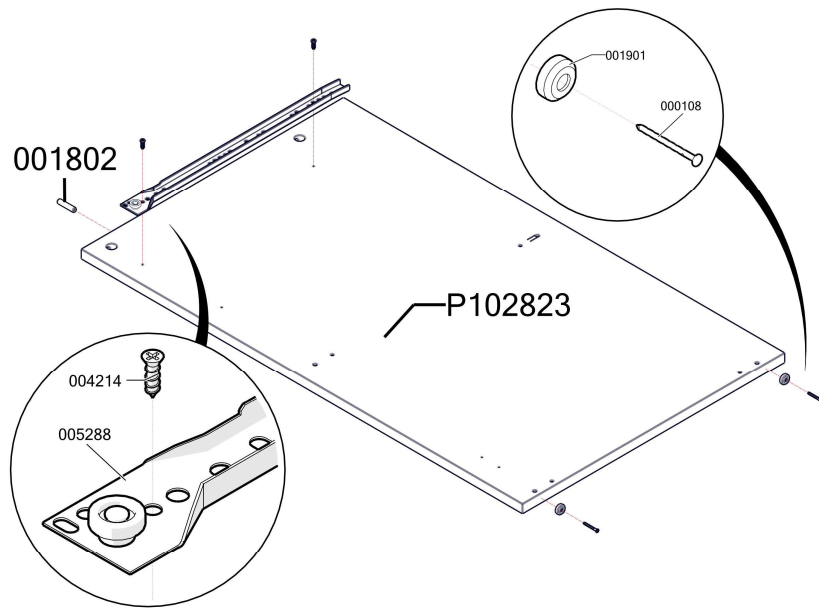

Note: the two upper holes have to be facing up.
Nota: los dos agujeros superiores deben estar hacia arriba.

9. Fix **metallic right slide** (005288) to **right division** (P102774) and **plastic foot** (001901).
 Fijar **pin** (001802), a **división derecha** (P102774) y fijar **pie de plástico** (001901).

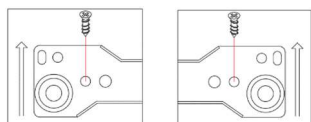
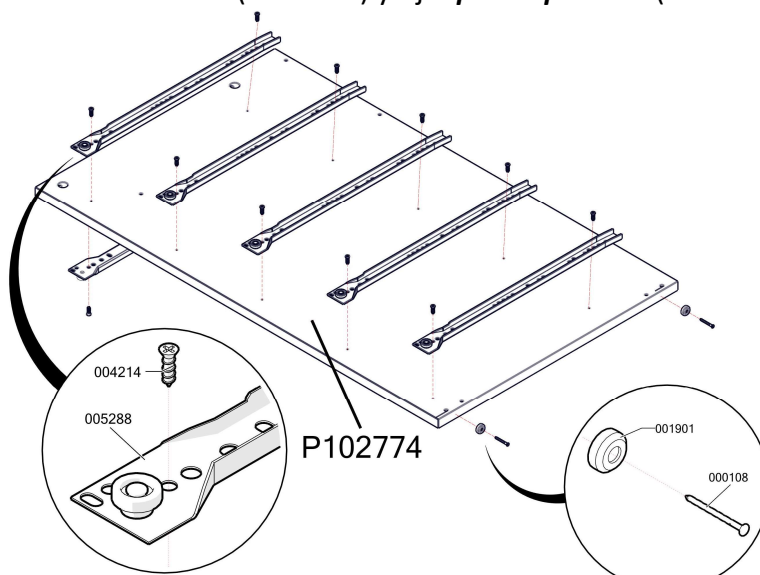

Note: the two upper holes have to be facing up.
Nota: los dos agujeros superiores deben estar hacia

10. Fix **metallic left slide** (005288) to **left division** (P102772) and **plastic foot** (001901).
 Fijar **pin** (001802), a **división izquierda** (P102772) y fijar **pie de plástico** (001901).

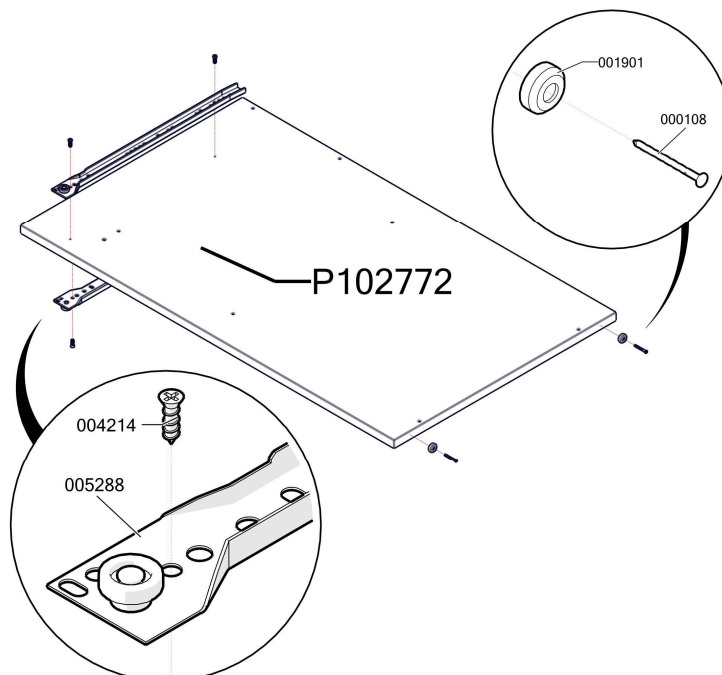

11. Fix the **wood pin** (001802) in the **larger part** (P102744) and install the **angle brackets** (000899).
 Fije el pasador de madera (001802) en la parte más grande (P102744) e instale los soportes angulares (000899).

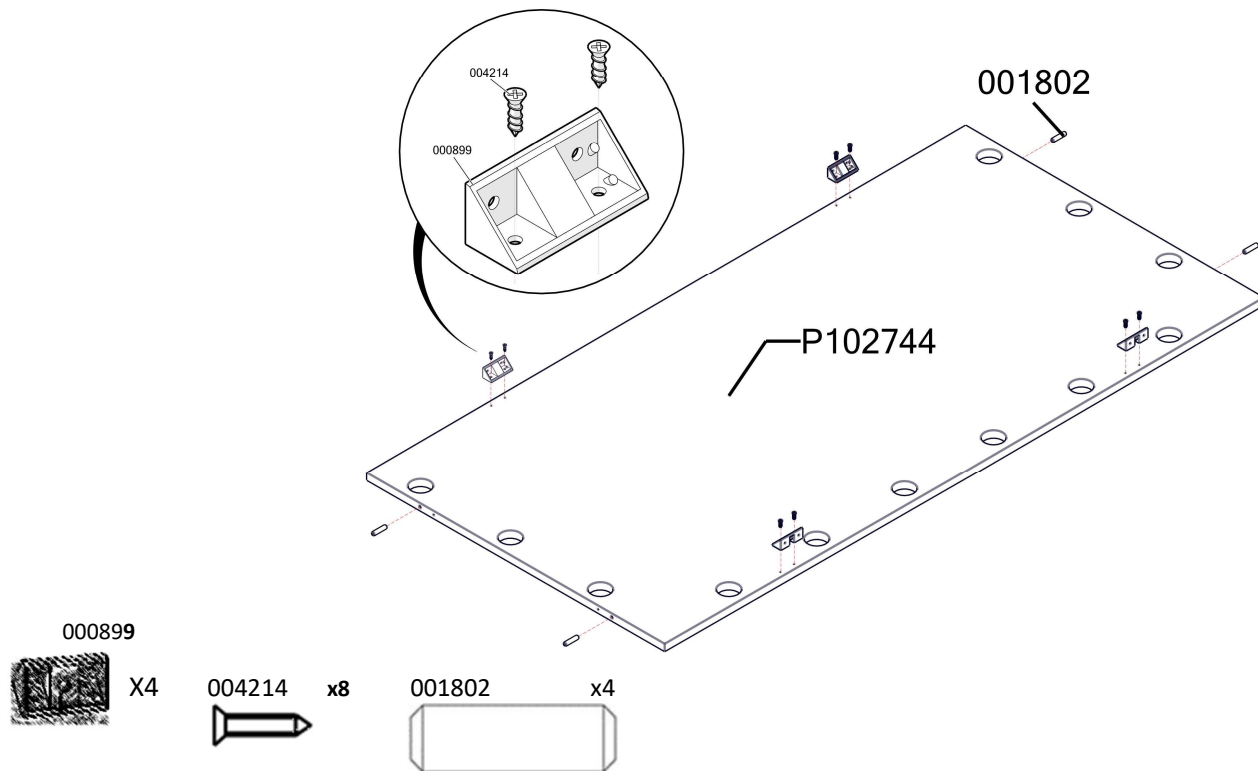



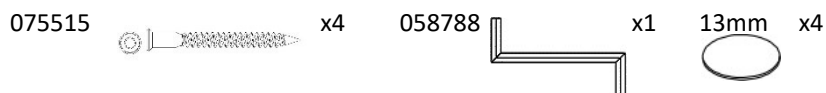
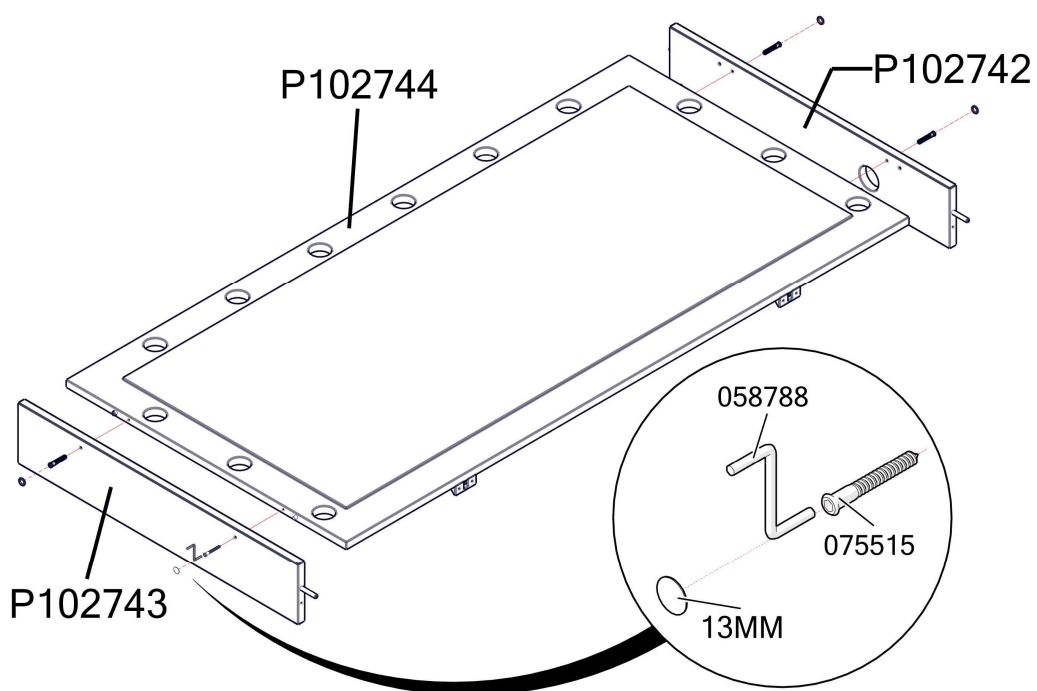

12. Fix **side tray** (P102742/P102743) to **mirror** (P102744).
 Fijar **travesaño lateral** (P102742/P102743) a **espejo** (P102744).

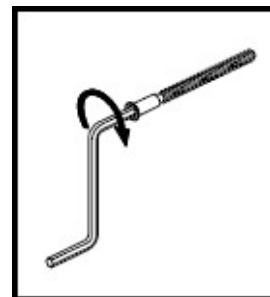
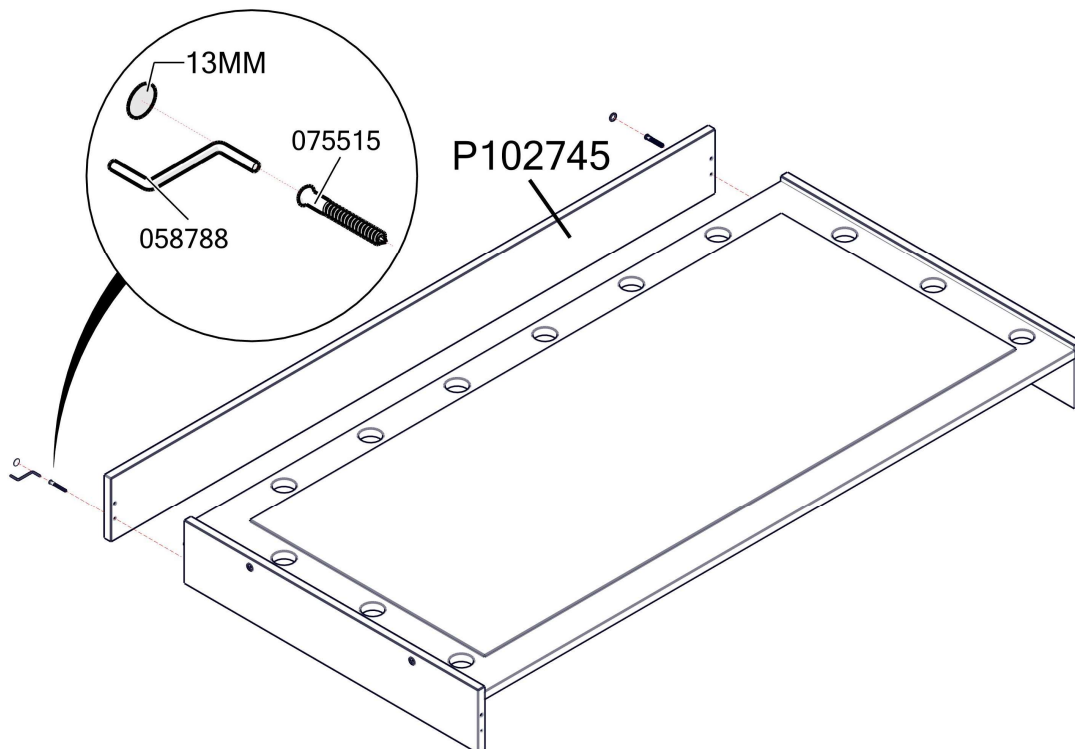

Need some Help? Call +1 (713) 701-5994 or email contact@boahaus.com
 ¿Necesitas ayuda? Llama +1 (713) 701-5994 o envía un email contact@boahaus.com



13. Fix **top tray** (P102745) to previous assembly.
Fijar **travesaño superior** (P102745) a ensamble previo.

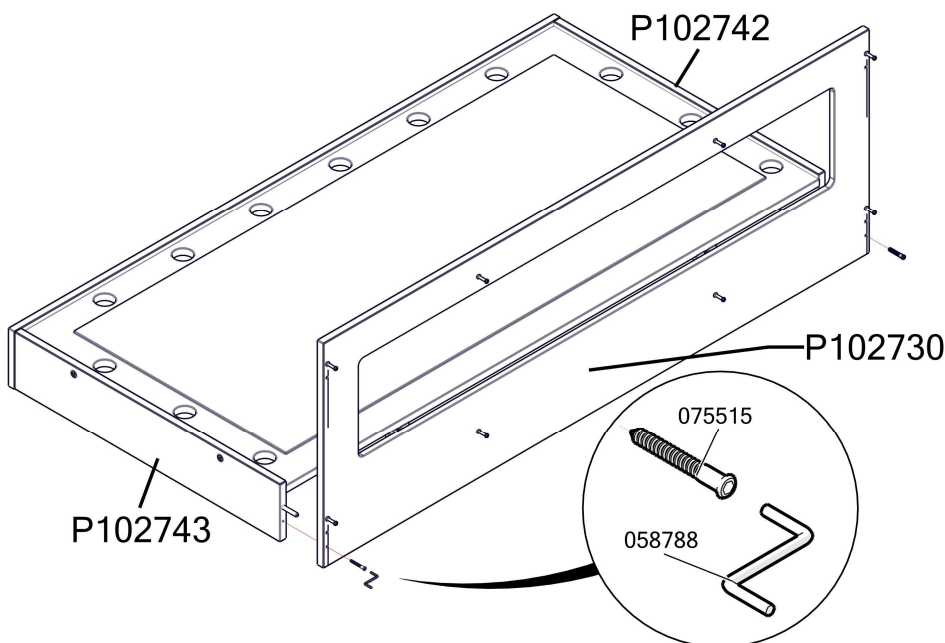

075515  x2 058788  x1 13mm  x2

14. Fix **top base** (P102770) to previous assembly.
Fijar **base superior** (P102770) a ensamble previo.



075515  x2 058788  x1 13mm  x2

15. Fix **crossbeam** (P102759) and **bases** (P102761) to **sides** (P102773/P102823) and **partitions** (P102772/P102774) and bottom (P102760).

Fijar **travesaño** (P102759) y **bases** (P102761) a **laterales** (P10262/P102756) y **división** (P102757/P102769) y fondo (P102760).

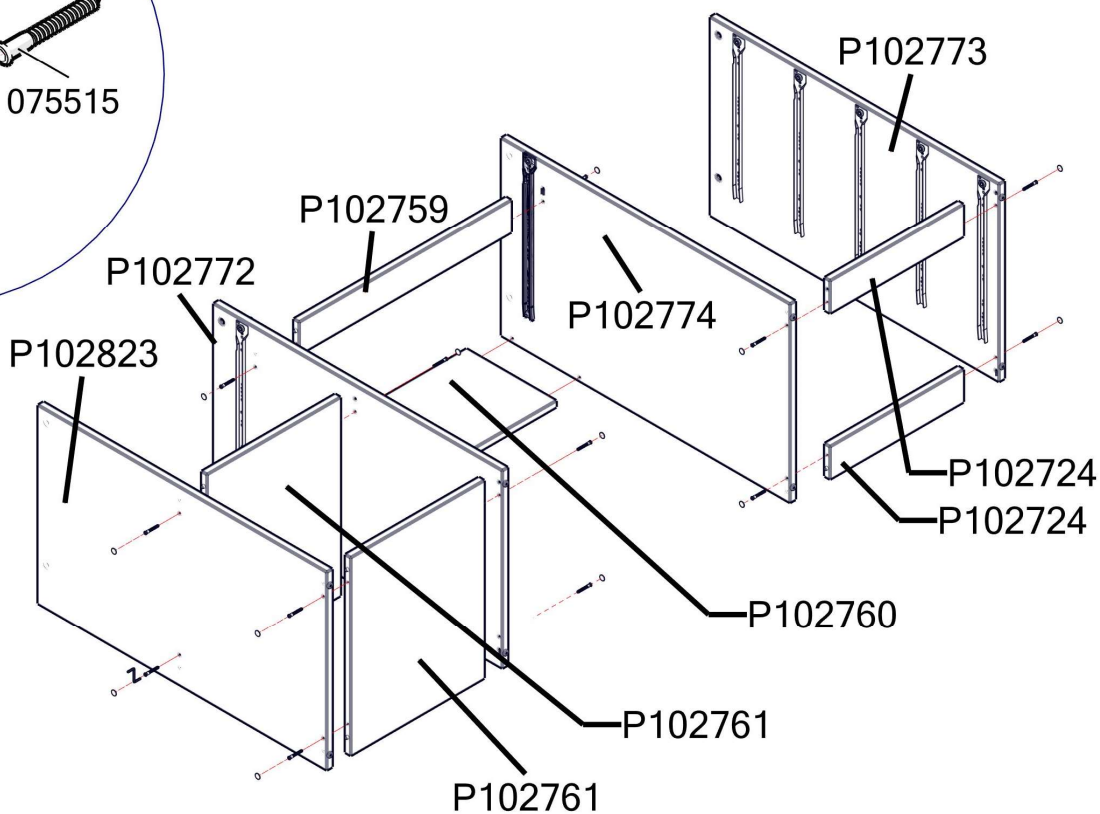
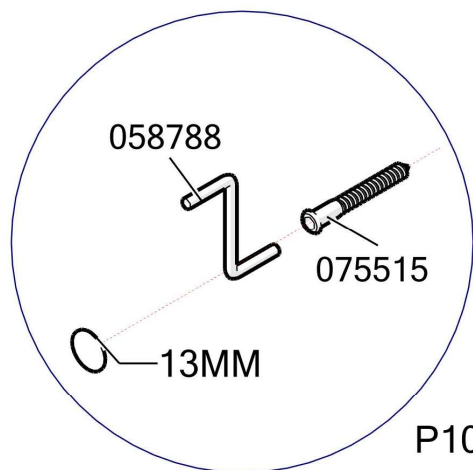

075515 x18

058788 x1

13mm x18



16. Fix both pre-assemblies
Fijar ambos ensambles previos (16 y 17).

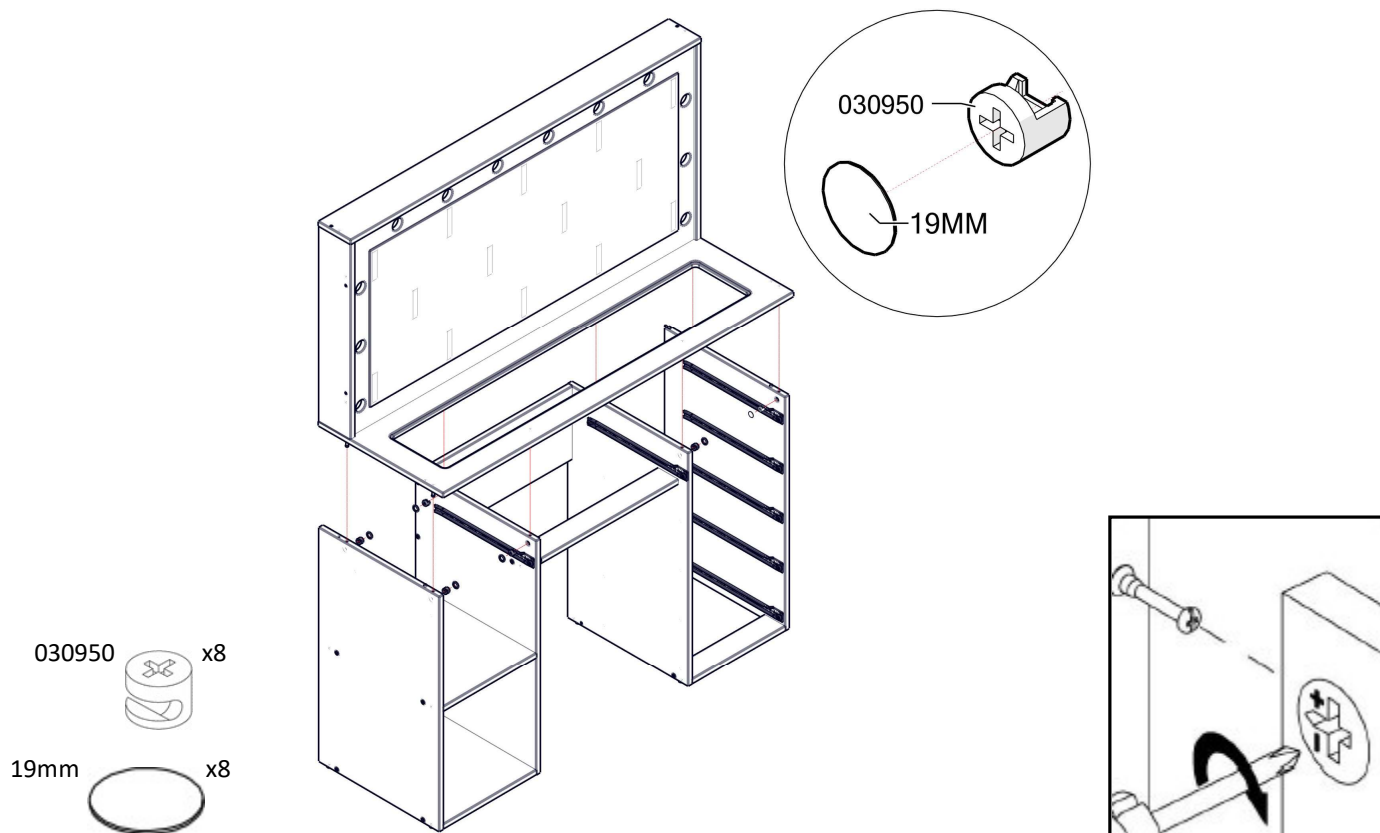

17. Fix **backboard** (P102738) to previous assembly.
Fijar **fondo** (P102738) a ensamble previo.

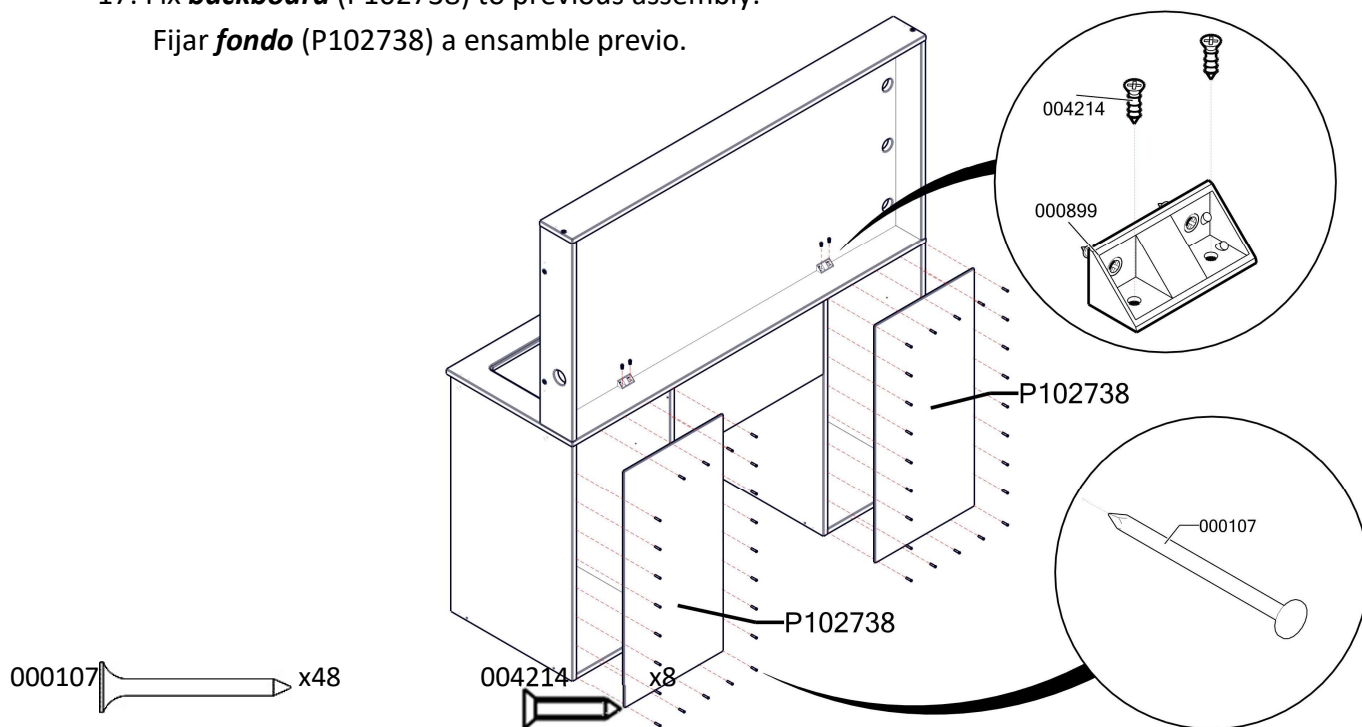

18. Fix **metallic angle plates** (055606) to previous assembly.
 Fijar **soporte de metal** (055606) a ensamble previo.

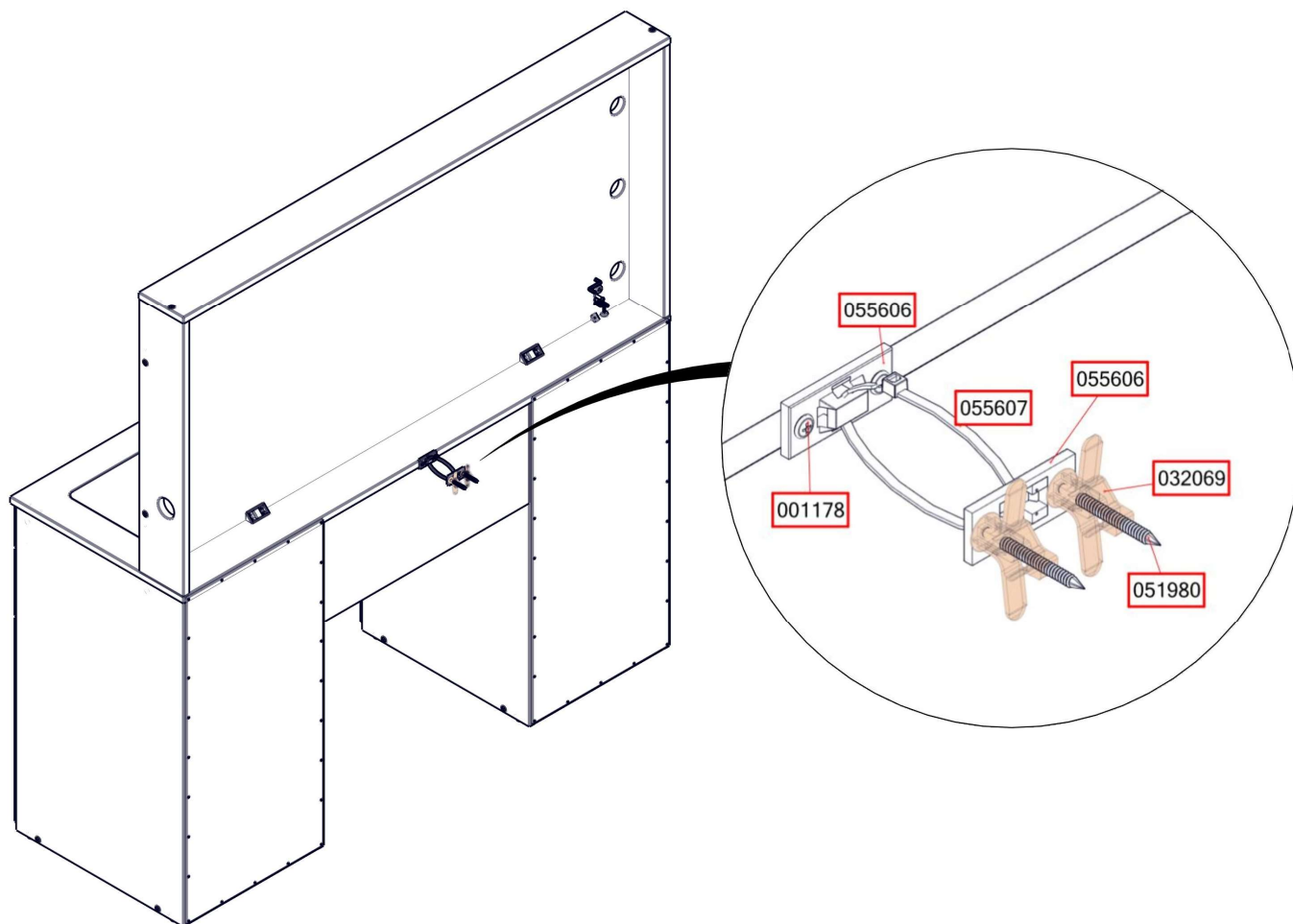

055606 x2



032069 x2

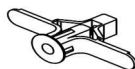

001178 x2

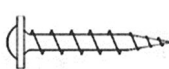

055607 x1



051980 x2



WARNING.

For security measures it is recommended to fix the furniture to the wall to avoid overturning of it, if this happens it can cause serious or fatal injuries.

ATENCIÓN.

Por medidas de seguridad se recomienda fijar el mueble a la pared para evitar volcamiento del mismo, si esto llegase a ocurrir puede causar lesiones graves o fatales.

19. Fix **wooden dowel** (001802) to **sides of drawer** (P102763/P102764) x4.
 Fije **pin** (P001802) al **lateral del cajón grande** (P102763/P102764) x4.

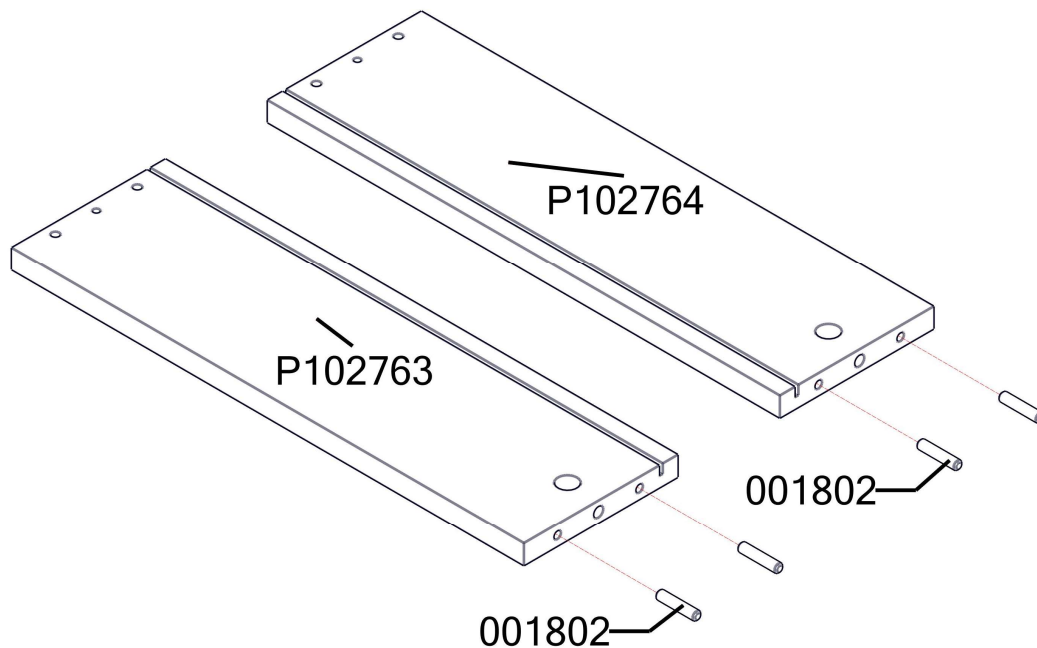

20. Fix **wooden dowel** (001802) to **sides of drawer** (P102731/P102732) x3.
 Fije **pin** (P001802) al **lateral del cajón** (P102763/P102764) x3.

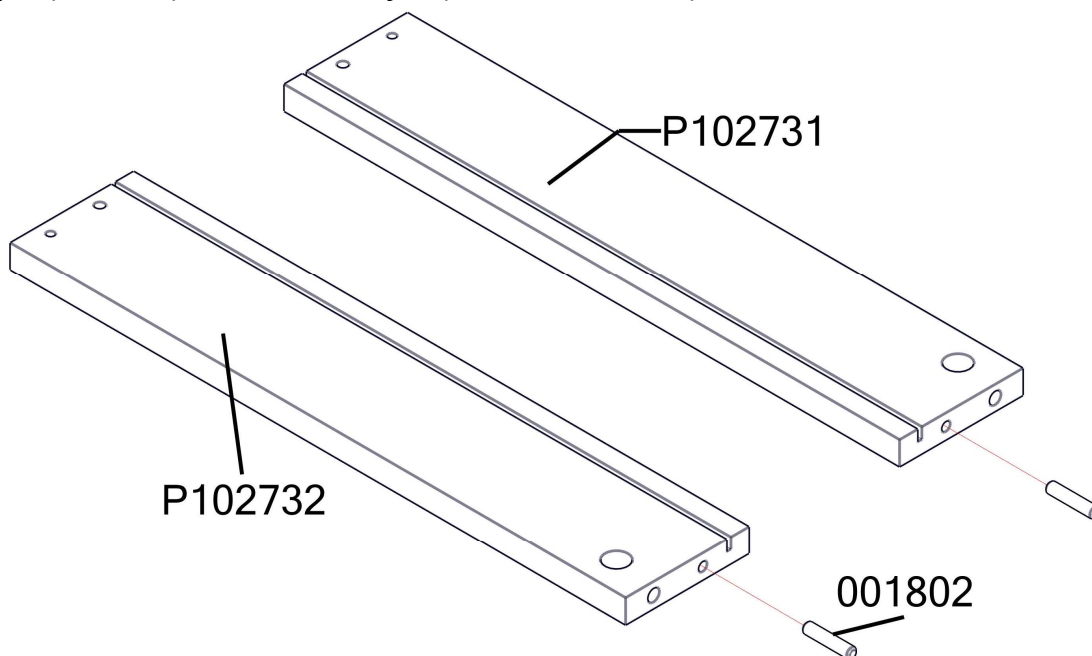

21. Fix **simple minifix screw** (030945) to **front of Drawer** (P102767) x4 to **front of Drawer** (P102740 x2 (P102741)).
 Fijar **tornillo minifix simple** (030945) a **frente de cajón** (P102767) x4 a **frente de cajón** (P102740) x2 (P102741).

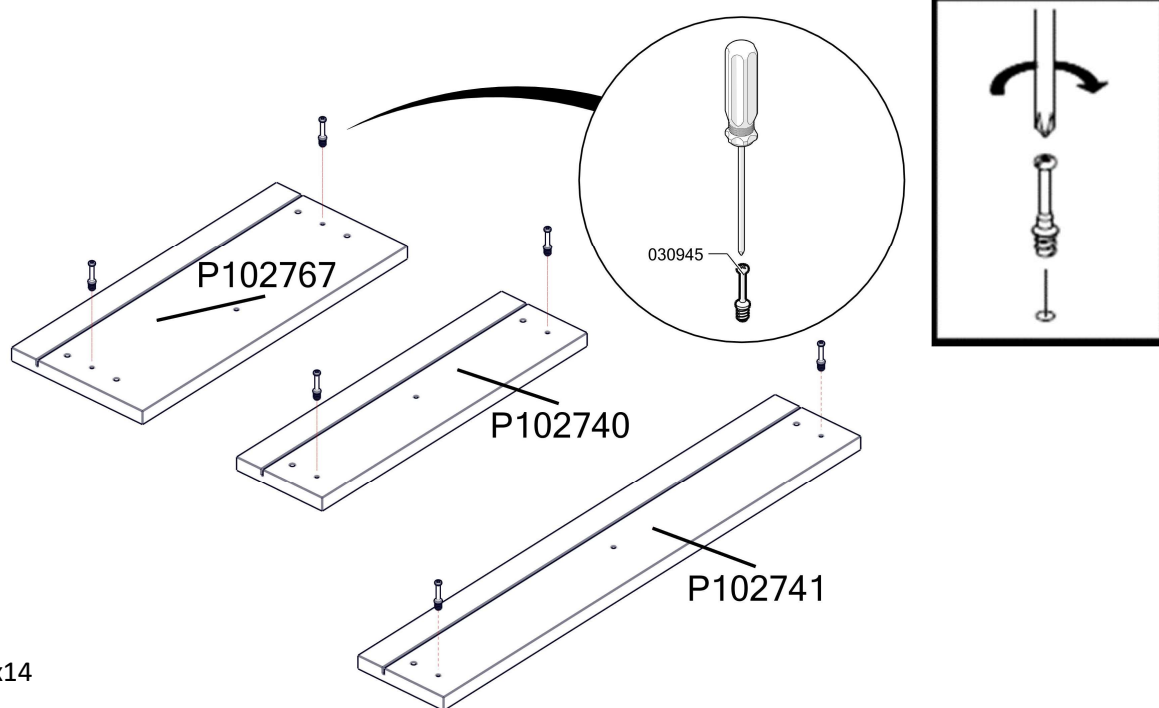

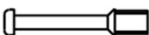
030945  x14

22. Fix **wooden dowel** (001802) to **rear of large drawer** (P102765) x4 and **rear of small drawer** (P102733) and (P102734) x2.
 Fije el **pin** (001802) al **posterior de cajón grande** (P102765) x4 y al **posterior de cajón pequeño** (P102733) y (P102734) x2.

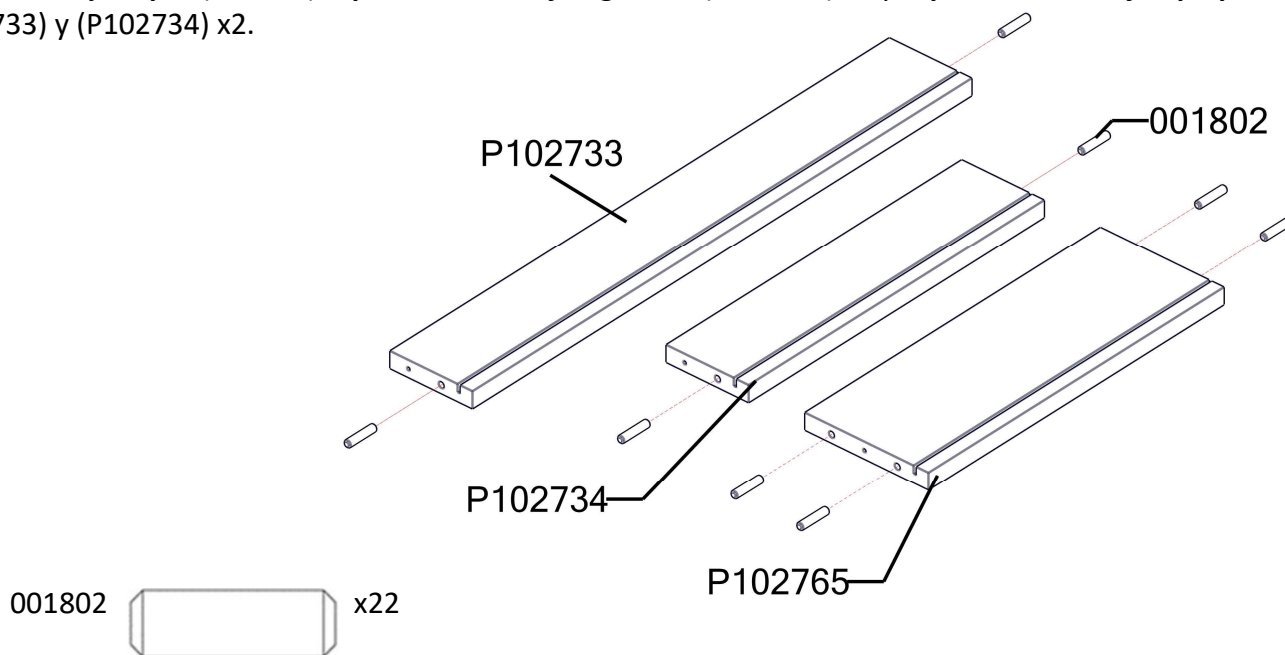

001802  x22

23. Attach the side of the **mean drawer** (P102763/P102764) x4 to the **back of the middle drawer** (P102765) x4 to **bottom of drawer** (P102737) x4.

Coloque el lateral del **cajón pequeño** (P102763/P102764) x4 en la **parte trasera del cajón central** (P102765) x4 a **fondo de cajón** (P102737) x4.

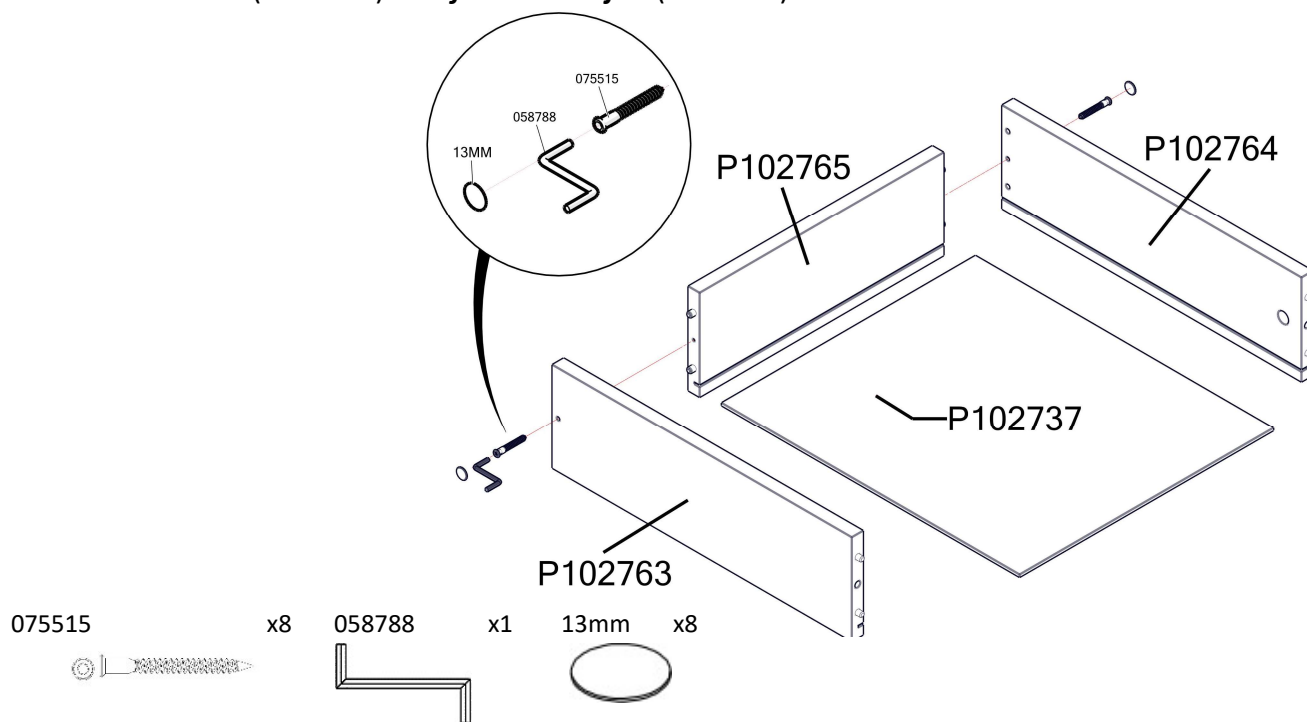

24. Fix **middle drawer front** (P102767) x4 and **handle** (062448) to previous assembly.

Fijar **frente de cajón medio** (P102767) x4 y **tirador** (062448) a ensamble previo.

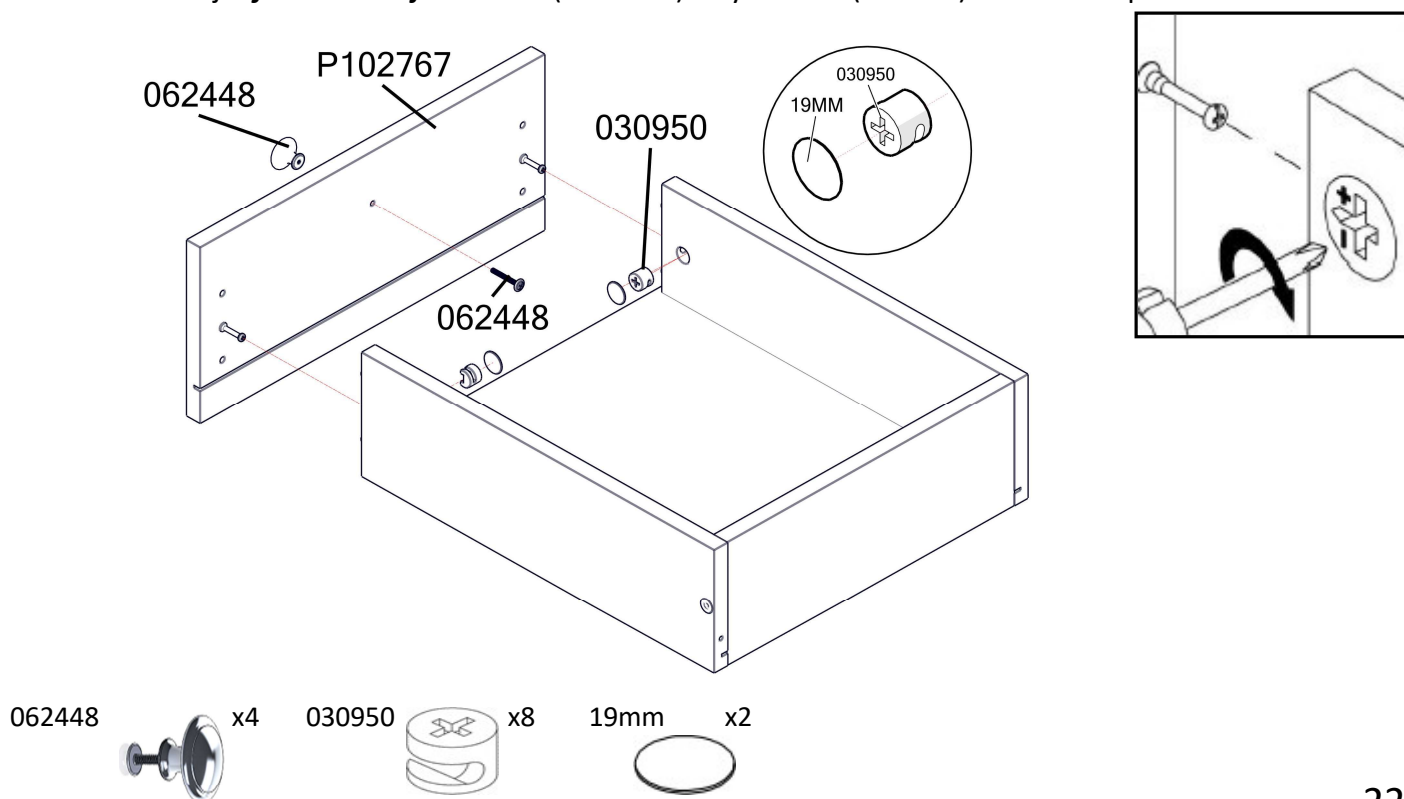

25. Attach the side of the **small drawer** (P102731/P102732) x2 to the **rear of the small drawer** (P102734) x2 and to **bottom of drawer** (P102737) x2.

Coloque el lateral del **cajón pequeño** (P102731/P102732) x2 en la parte posterior del **cajón pequeño** (P102734) x2 a **fondo de cajón** (P102737) x2.

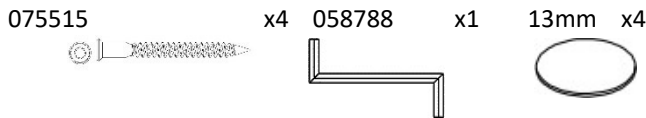
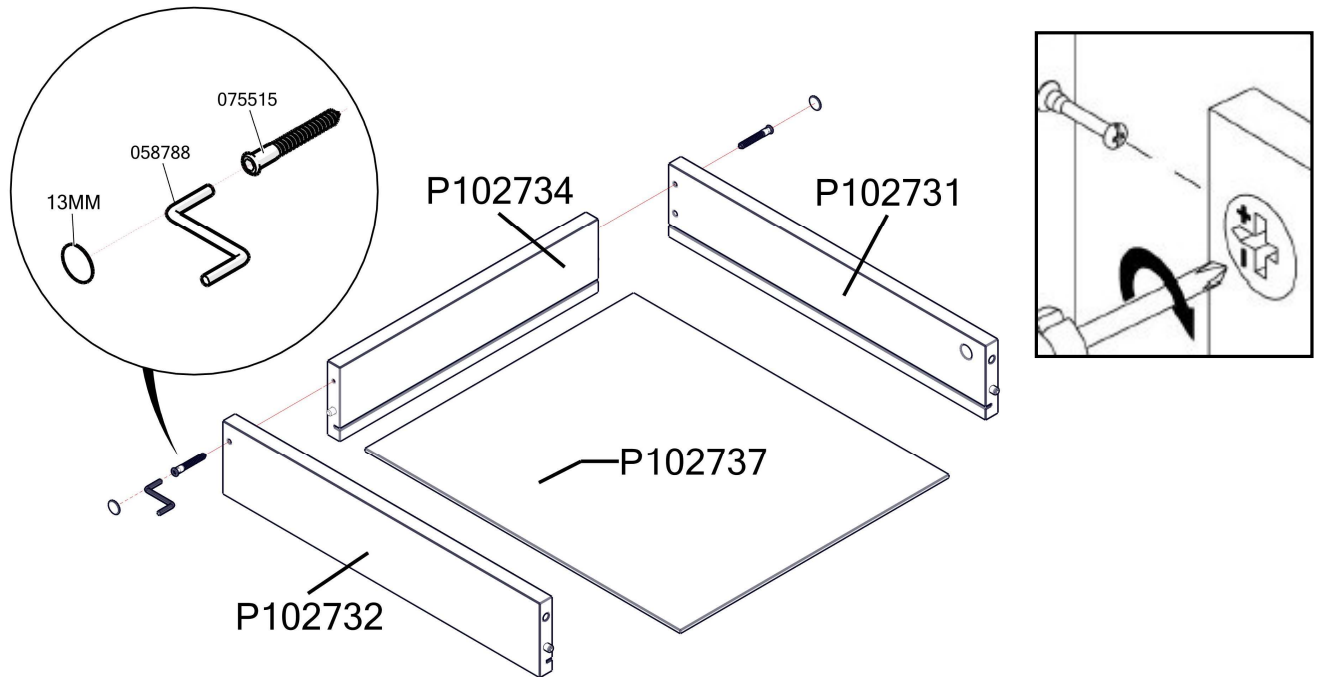

26. Fix **front large drawer** (P102740) x2 and **handle** (062448) to previous assembly.

Fijar **frente del cajón grande** (P102740) x2 y **tirador** (062448) a ensamble previo

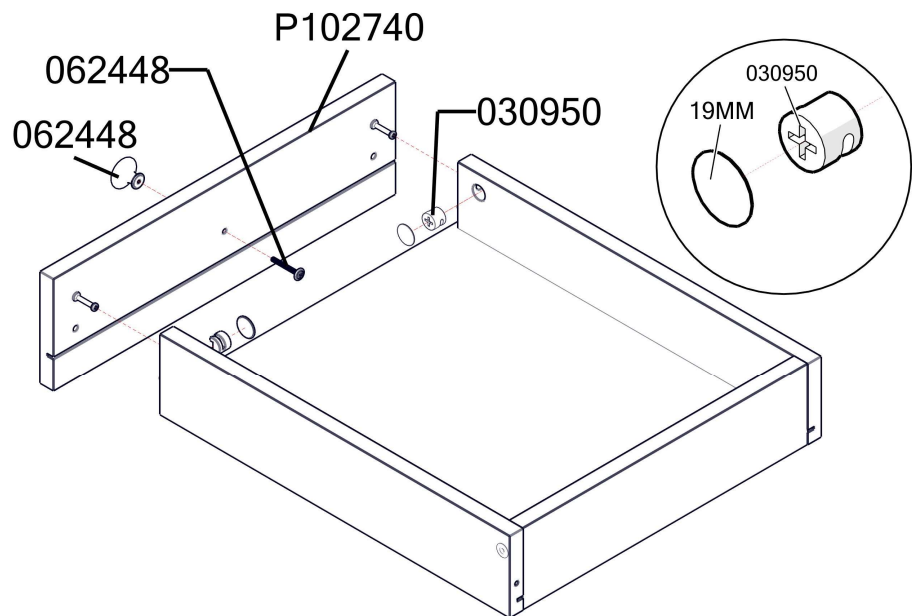

Need some Help? Call +1 (713) 701-5994 or email contact@boahaus.com
 ¿Necesitas ayuda? Llama +1 (713) 701-5994 o envía un email contact@boahaus.com

27. Fix **drawer support** (018458) x12 and **screw** (005256) to small drawer x6.
 Fijar **soporte para cajones** (018458) x12 y a **tornillo** (005256) cajón pequeño x6.

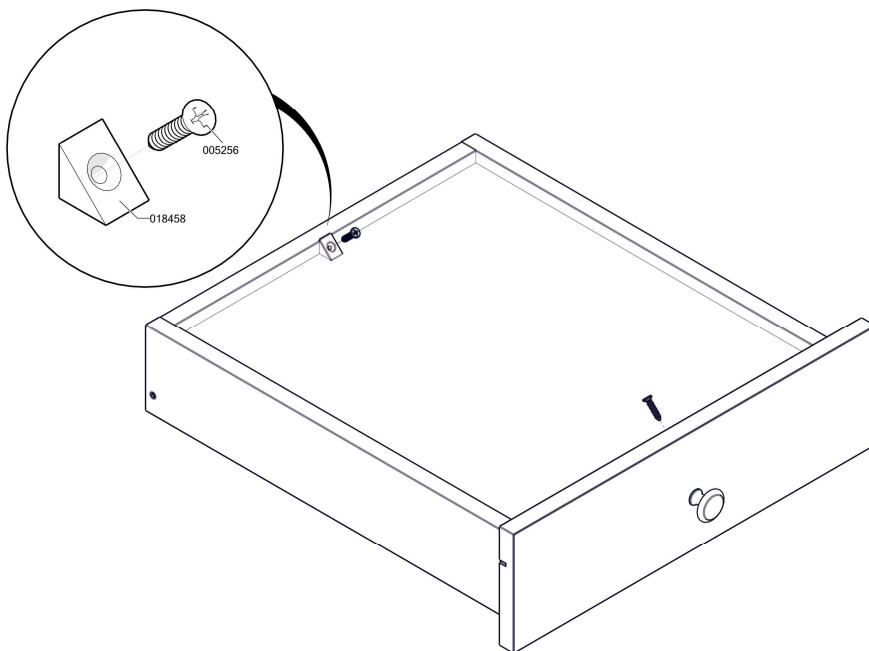

018458 x12



005256 x12



28. Fix **left drawer slide** (005288) x6 and **drawer slide** (005288) x6 to for the **small and medium drawer** x6.

Fijar **corredera de cajón izquierdo** (005288) x6 y **corredera de cajón derecho** (005288) x6 para **cajones pequeños y medianos** x6.

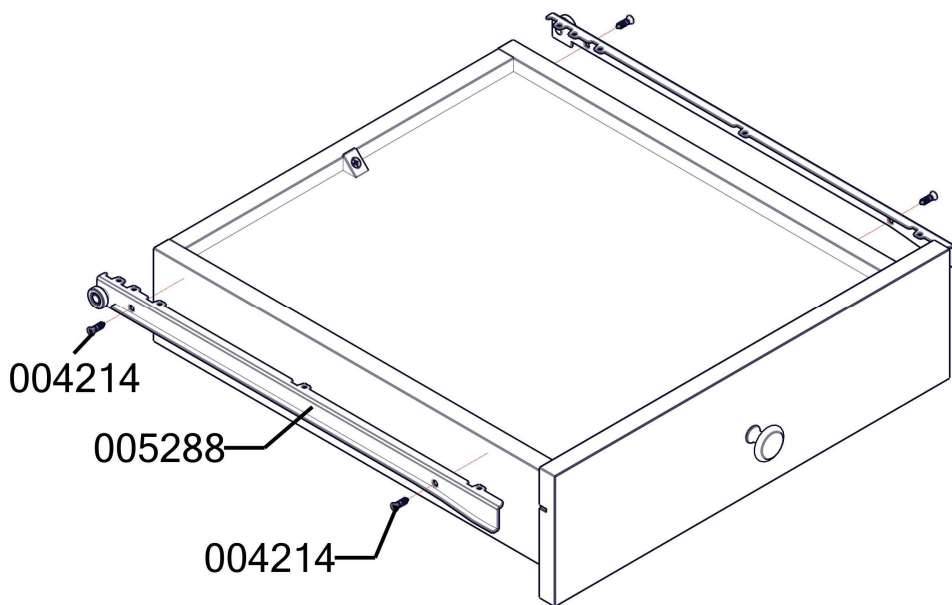
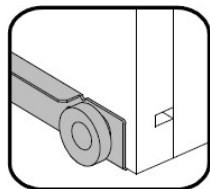

005288



x6

005288

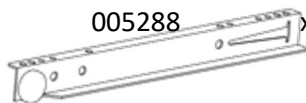

x6



004214 x24

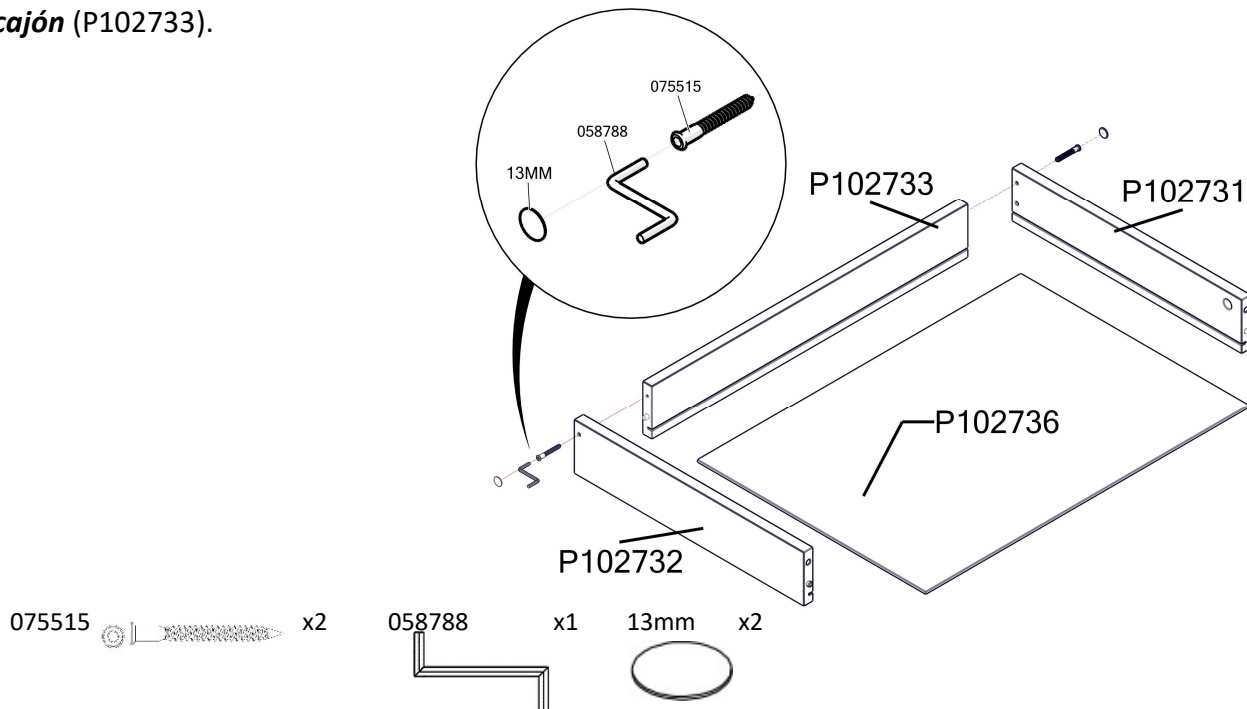

29. Fix *side of drawer* (P102731/P102732) and *bottom of drawer* (P102736) to *rear of drawer* (P102733).

Fijar *lateral de cajón central* (P102731/P102732) y *fondo de cajón* (P102736) a *trasero de cajón* (P102733).

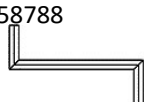



- 075515  x2
- 058788  x1
- 13mm  x2

30. Fix *front large drawer* (P102741) and *handle* (062448) to previous assembly.

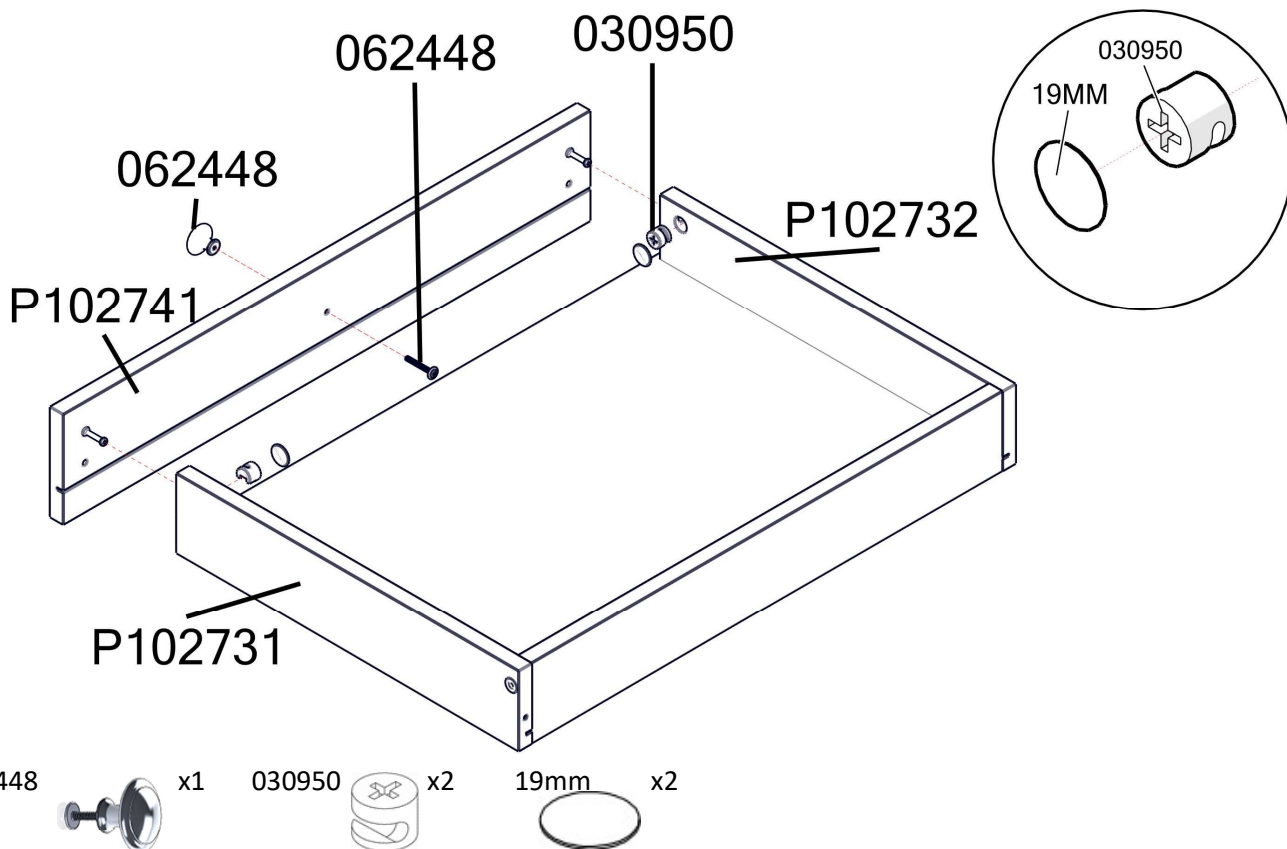
Fijar *frente del cajón grande* (P102741) y *tirador* (062448) a ensamble previo.



- 062448  x1
- 030950  x2
- 19mm  x2

31. Fix **drawer support** (018458) and **screw** (005256) to larger drawer.
 Fijar **soporte para cajones** (018458) y a **tornillo** (005256) cajón más grande.

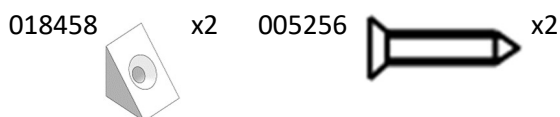
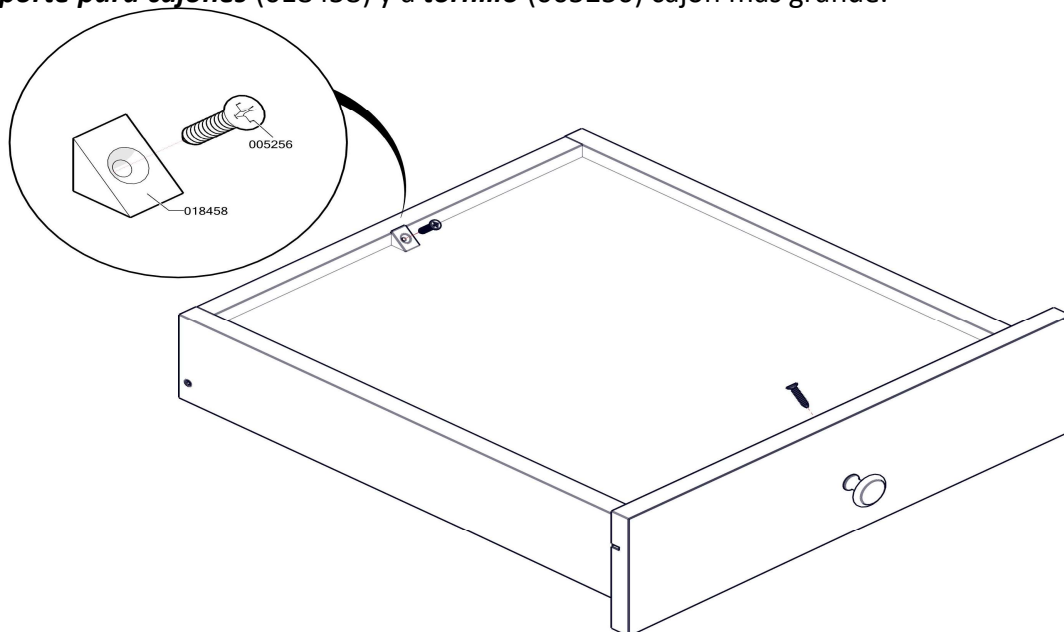

32. Fix **left drawer slide** (005288) and **right drawer slide** (005288) to larger drawer.
 Fijar **corredera de cajón izquierdo** (005288) y **corredera de cajón derecho** (005288) a cajón más grande.

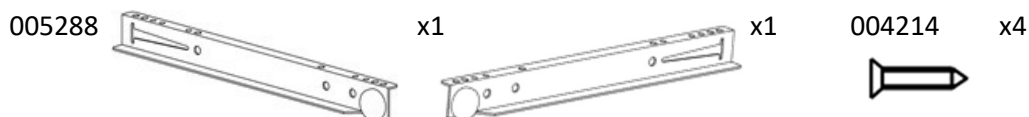
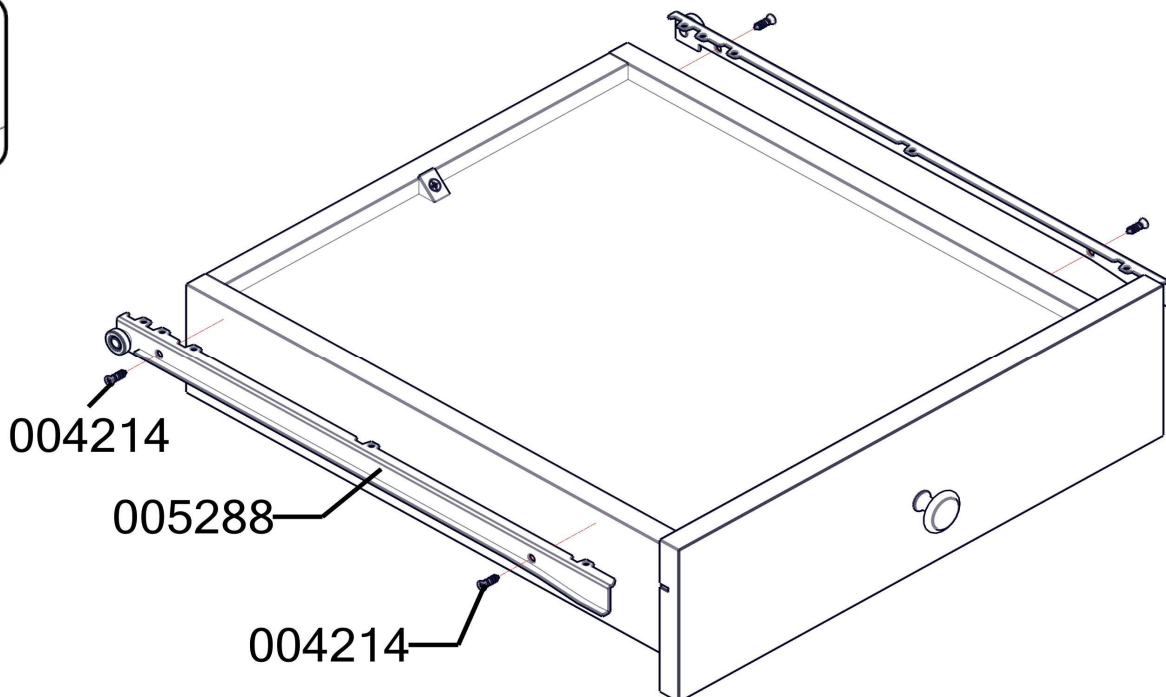
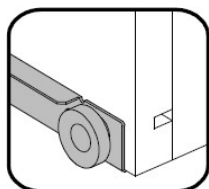

33. Place drawers.
Colocar cajones.

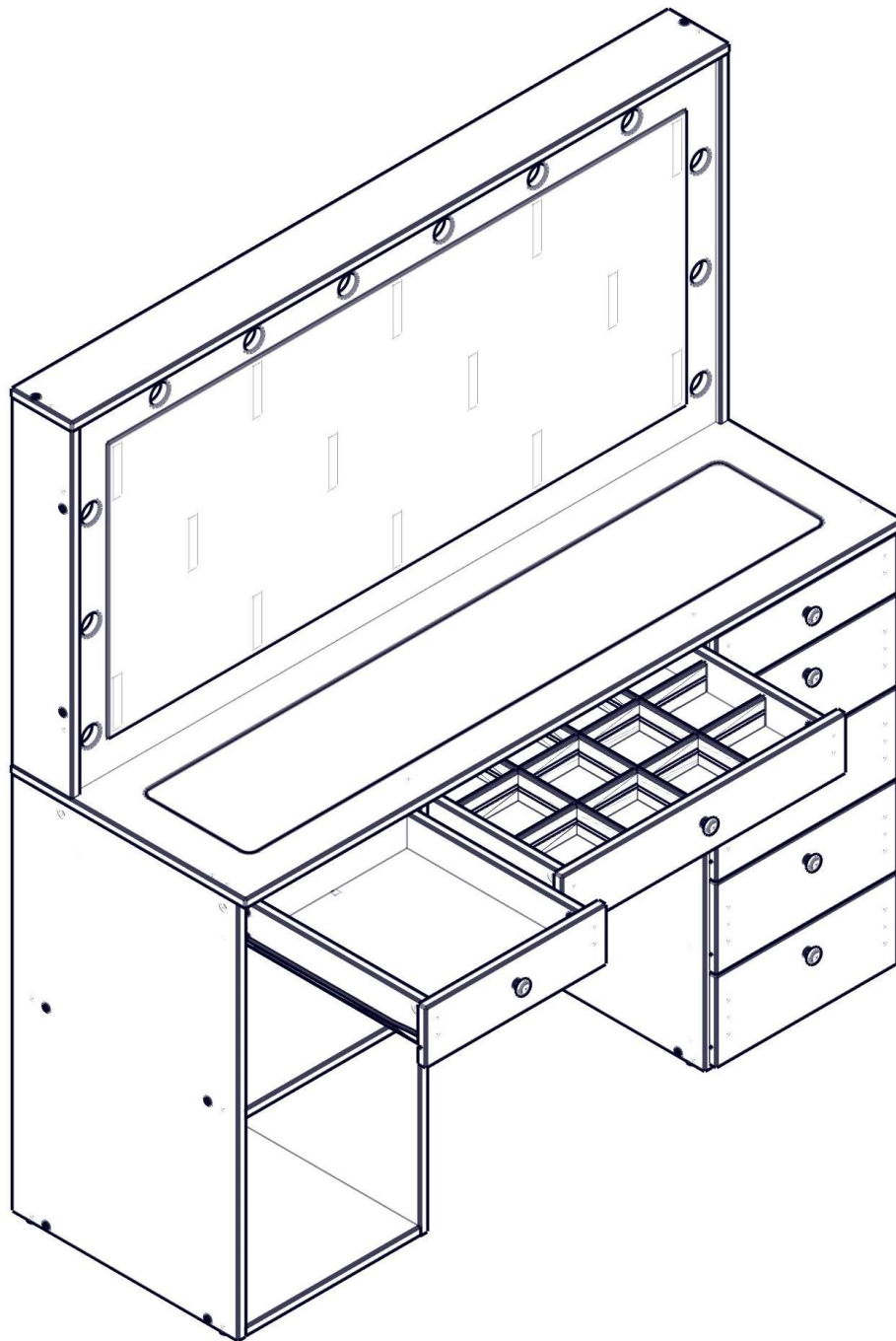

068915 x1

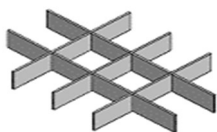

IMPORTANT INFORMATION, PLEASE READ THE INSTRUCTIONS CAREFULLY.

1. Fix the mounting bracket (055606) on the back of the furniture as shown in the figure, using the screws (001178)
2. Locate a post on the wall to attach the mounting bracket (055606), place it approximately 1" below the one that is attached to the furniture. Use wall anchors (032069) and screws (051980).
3. Move the furniture to its final position, taking care to align the wall mounting bracket with the cabinet mounting bracket. Pass the clamp (055607) through each bracket as shown in the picture and tighten enough until it is snug.
4. Make sure all parts are tight.

INFORMACION IMPORTANTE, LEA POR FAVOR CUIDADOSAMENTE LAS INSTRUCCIONES.

1. Monte el soporte de montaje (055606) en la parte posterior del mueble como se muestra en la figura anterior, utilizando los tornillos (001178)
2. Localice un poste en la pared en donde fijará el soporte de montaje (055606), colóquelo aproximadamente 1" por debajo del que fijó en el mueble. Utilice los anclajes de pared (032069) y los tornillos (051980).
3. Mueva el mueble a su posición final, cuidando de alinear el soporte de montaje de la pared con el soporte de montaje del mueble. Pase la abrazadera (055607) a través de cada soporte como se muestra en la imagen y apriete lo suficiente hasta que quede ajustado.

Asegúrese que todas las piezas estén firmemente ajustadas.

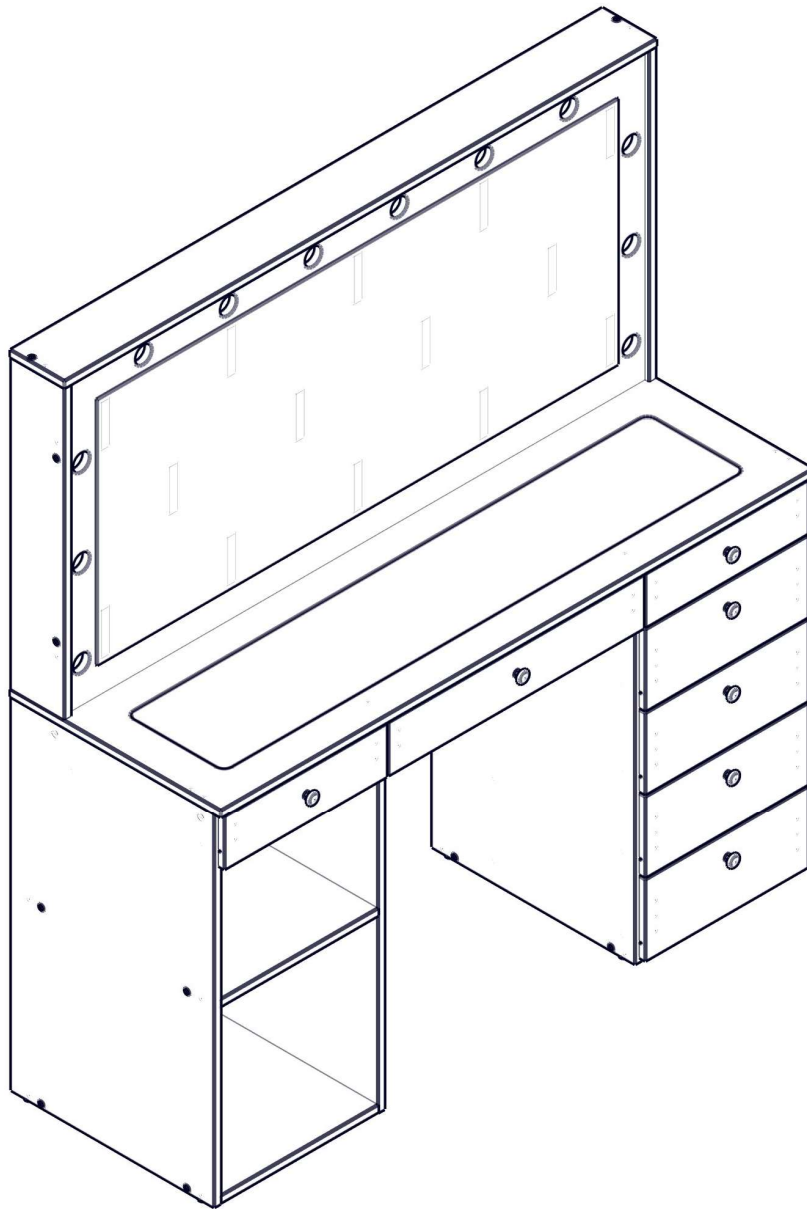

Congratulations, you have assembled your DRESSING TABLE WITH MIRROR!!!

¡¡¡Felicitaciones, has armado tu Tocador con Espejo!!!

Need some Help? Call +1 (713) 701-5994 or email contact@boahaus.com
¿Necesitas ayuda? Llama +1 (713) 701-5994 o envía un email contact@boahaus.com

1647 Boahaus DRESSING TABLE WITH MIRROR Warranty 6-Months

Limited Warranty

- a. Boahaus, LLC provides limited warranty coverage to the original purchaser of this product for a period of six months from the date of purchase against defects in materials or workmanship of Boahaus furniture components. As used in this Warranty, “defect” means imperfections in components which substantially impair the utility of the product. This Warranty gives you specific legal rights, and you may also have other rights which vary from state to state.
- b. There is no warranty coverage for defects or conditions that result from the failure to follow product assembly instructions, information or warnings, misuse or abuse, intentional damage, fire, flood, alteration or modification of the product, or use of the product in a manner inconsistent with its intended use, nor any condition resulting from incorrect or inadequate maintenance, cleaning, or care. There is also no warranty coverage for rented products or any products purchased “used” or “as is”, at a distress or going-out-of business sale, or from a liquidator.
- c. As the exclusive remedy under this Warranty, Boahaus will (at its sole option) repair, replace or refund the value of any defective furniture component. Boahaus may require independent confirmation of the claimed defect and proof of purchase. Replacement parts will be warranted for only the remaining period of the original Warranty. BOAHAUS SHALL HAVE NO LIABILITY for ANY INCIDENTAL OR CONSEQUENTIAL DAMAGES OF ANY KIND and all such damages are EXCLUDED FROM THIS WARRANTY, such as loss of use, disassembly, transportation, labor or damage to property on or near the product. Some states do not allow the exclusion or limitation of incidental or consequential damages, so the above limitation or exclusion may not apply to you.
- d. This Warranty applies only to warranted defects that first arise and are transferred to subsequent owners or users of the product, and it shall be immediately void in the event the product is resold, transferred, leased or rented to any third party or person other than the original purchaser.
- e. THERE ARE NO OTHER WARRANTIES APPLICABLE TO THIS PRODUCT. Under the laws of certain states, there may be no implied warranties from Boahaus and all implied warranties, INCLUDING ANY IMPLIED WARRANTY OF MERCHANTABILITY OR FITNESS FOR A PARTICULAR PURPOSE are disclaimed where allowed by law. TO THE EXTENT ANY IMPLIED WARRANTIES ARE APPLICABLE, ANY IMPLIED WARRANTIES, INCLUDING ANY IMPLIED WARRANTY OF MERCHANTABILITY OR FITNESS FOR A PARTICULAR PURPOSE, ARE LIMITED IN DURATION TO THE DURATION OF THIS EXPRESS WARRANTY or the minimum period allowed by law, whichever is shorter. Some states do not allow limitations on how long an implied Warranty lasts, so the above limitation may not apply to you.
- f. For Warranty inquiries, questions about disposition or claims, please visit our website www.boahaus.com. You can also contact Boahaus at +1 (713) 701-5994 or email at administracion@boahaus.com. Boahaus may require Warranty claims to be submitted in writing to:

Boahaus LLC.
1250-1252
Ave. Franklin Delano Roosevelt,
San Juan, PR 00926.

Please include your sales receipt or other proof of purchase and a specific description of the product defect.

Garantía de Tocador con Espejo 1647 Boahaus

Garantía limitada de 6 meses

1. Boahaus, LLC proporciona cobertura de garantía limitada al comprador original de este producto por un período de 6 meses a partir de la fecha de compra contra defectos en materiales o mano de obra de componentes de muebles de Boahaus. Como se especifica en esta Garantía, "defecto" significa imperfecciones en componentes que perjudican sustancialmente la utilidad del producto. Esta Garantía le otorga derechos legales específicos y también puede tener otros derechos que varían de un estado a otro.
2. No hay cobertura de garantía por defectos o condiciones que resulten del incumplimiento de las instrucciones del producto, o advertencias, uso indebido o abuso, daño intencional, incendio, inundación, alteración o modificación del producto o uso del producto de manera inconsistente con su uso previsto, o cualquier condición resultante de mantenimiento incorrecto o inadecuado, limpieza o cuidado. Tampoco hay cobertura de garantía para productos alquilados o cualquier producto comprado "usado" o "tal cual", en una venta de emergencia o de salida de la empresa, o de un liquidador.
3. Boahaus puede requerir una confirmación independiente del defecto reclamado y un comprobante de compra. Las piezas de repuesto estarán garantizadas durante el período restante de la garantía original. BOAHAUS NO TENDRÁ NINGUNA RESPONSABILIDAD POR CUALQUIER DAÑO INCIDENTAL y todos estos daños ESTÁN EXCLUIDOS DE ESTA GARANTÍA, tales como pérdida de uso, desmontaje, transporte, mano de obra o daños a la propiedad en o cerca del producto. Algunos estados no permiten la exclusión o limitación de daños incidentales o consecuentes, por lo que la limitación o exclusión anterior puede no aplicarse a usted.
4. Esta Garantía se aplica únicamente a los defectos garantizados que surgen y se informan a Boahaus dentro del período de cobertura de la garantía. La garantía no puede ser transferida a los propietarios o usuarios posteriores del producto, y será inmediatamente nula en caso de que el producto sea revendido, transferido, arrendado o alquilado a cualquier tercero o persona que no sea el comprador original.
5. NO HAY OTRAS GARANTÍAS APLICABLES A ESTE PRODUCTO. Bajo las leyes de ciertos estados, no puede haber garantías implícitas de Boahaus y todas las garantías implícitas, INCLUYENDO CUALQUIER GARANTÍA IMPLÍCITA DE COMERCIABILIDAD O ADECUACIÓN PARA UN PROPÓSITO EN PARTICULAR, están exoneradas cuando permitido por la ley. TODAS LAS GARANTÍAS IMPLÍCITAS SON APLICABLES, LAS GARANTÍAS IMPLÍCITAS, INCLUIDAS CUALQUIER GARANTÍA IMPLÍCITA DE COMERCIABILIDAD O ADECUACIÓN PARA UN PROPÓSITO PARTICULAR, ESTÁN LIMITADAS EN DURACIÓN A LA DURACIÓN DE ESTA GARANTÍA EXPRESA o el período mínimo permitido por la ley, cualquiera que sea más corto. Algunos estados no permiten limitaciones sobre la duración de una garantía implícita, por lo que es posible que la limitación anterior no se aplique a usted.
6. Para consultas sobre la garantía, preguntas sobre la disposición o reclamaciones, visite nuestro sitio web www.boahaus.com. También puede ponerse en contacto con Boahaus en +1 (713) 701-5994 o por correo electrónico en administracion@boahaus.com. Boahaus puede requerir que los reclamos de garantía sean presentados por escrito a:

Boahaus LLC.
1250-1252
Ave. Franklin Delano Roosevelt,
San Juan, PR 00926.

Incluya su recibo de compra u otra prueba de compra y una descripción específica del defecto del producto.