

# ASSEMBLY INSTRUCTIONS MANUAL DE MONTAGEM / INSTRUCCIONES DE ARMADO

ZAIRA WARDROBE - 2 DOORS E DRAWERS

ROUPEIRO ZAIRA - 2 PORTAS 2 GAVETAS

ROPERO ZAIRA - 2 PUERTAS 2 CAJONES

Reference  
Referência  
Referencia

**210433**

Revised  
Revisão  
Revisión

**00**



ENGLISH  
PORTUGUÊS  
ESPAÑOL

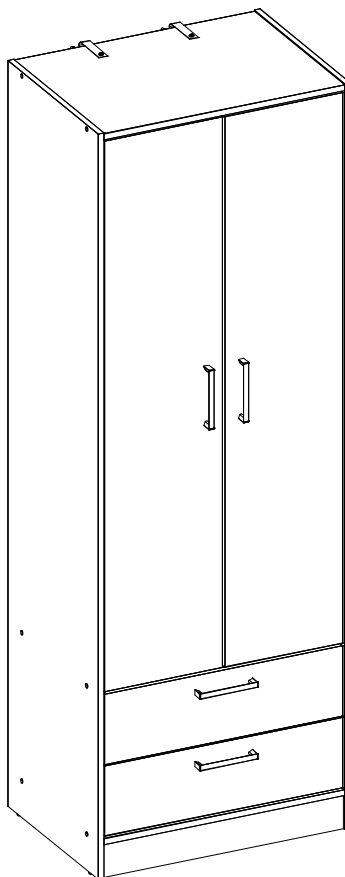

MAXIMUM RECOMMENDED WEIGHT  
BEING THIS EVENLY DISTRIBUTED.

PESO MÁXIMO RECOMENDADO SENDO  
ESTE DISTRIBUÍDO UNIFORMEMENTE.

PESO MÁXIMO RECOMENDADO SIENDO  
ESTE UNIFORMEMENTE DISTRIBUIDO.

	LB	KG
D	11	5
E	17	8
F	22	10

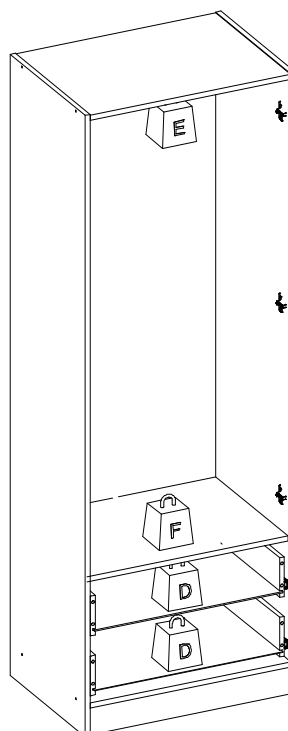

N°	Measures_Inches	Medidas_cm	Qty./Qtd.
01	23 3/8 x 17 1/2 x 5/8	59.3 x 44.5 x 1.5	1
02	23 3/8 x 16 3/4 x 5/8	59.3 x 42.7 x 1.5	1
03	23 3/8 x 17 1/2 x 5/8	59.3 x 44.5 x 1.5	1
04	70 7/8 x 17 1/2 x 5/8	180.0 x 44.5 x 1.5	1
05	70 7/8 x 17 1/2 x 5/8	180.0 x 44.5 x 1.5	1
06	23 3/8 x 3 1/4 x 5/8	59.3 x 8.1 x 1.5	2
07	52 3/8 x 11 1/2 x 5/8	133.0 x 29.1 x 1.5	2
08	23 1/8 x 6 3/4 x 5/8	58.7 x 17.0 x 1.5	2
09	21 3/8 x 4 1/2 x 5/8	54.4 x 11.5 x 1.5	2
10	22 x 13 7/8 x 1/8	55.8 x 35.4 x 0.3	2
11	67 1/4 x 12 x 1/8	170.7 x 30.4 x 0.3	2
102	14 x 4 1/2 x 5/8	35.5 x 11.5 x 1.5	2
103	14 x 4 1/2 x 5/8	35.5 x 11.5 x 1.5	2

## PARTS IDENTIFICATION IDENTIFICAÇÃO DAS PEÇAS / IDENTIFICACIÓN DE LAS PIEZAS

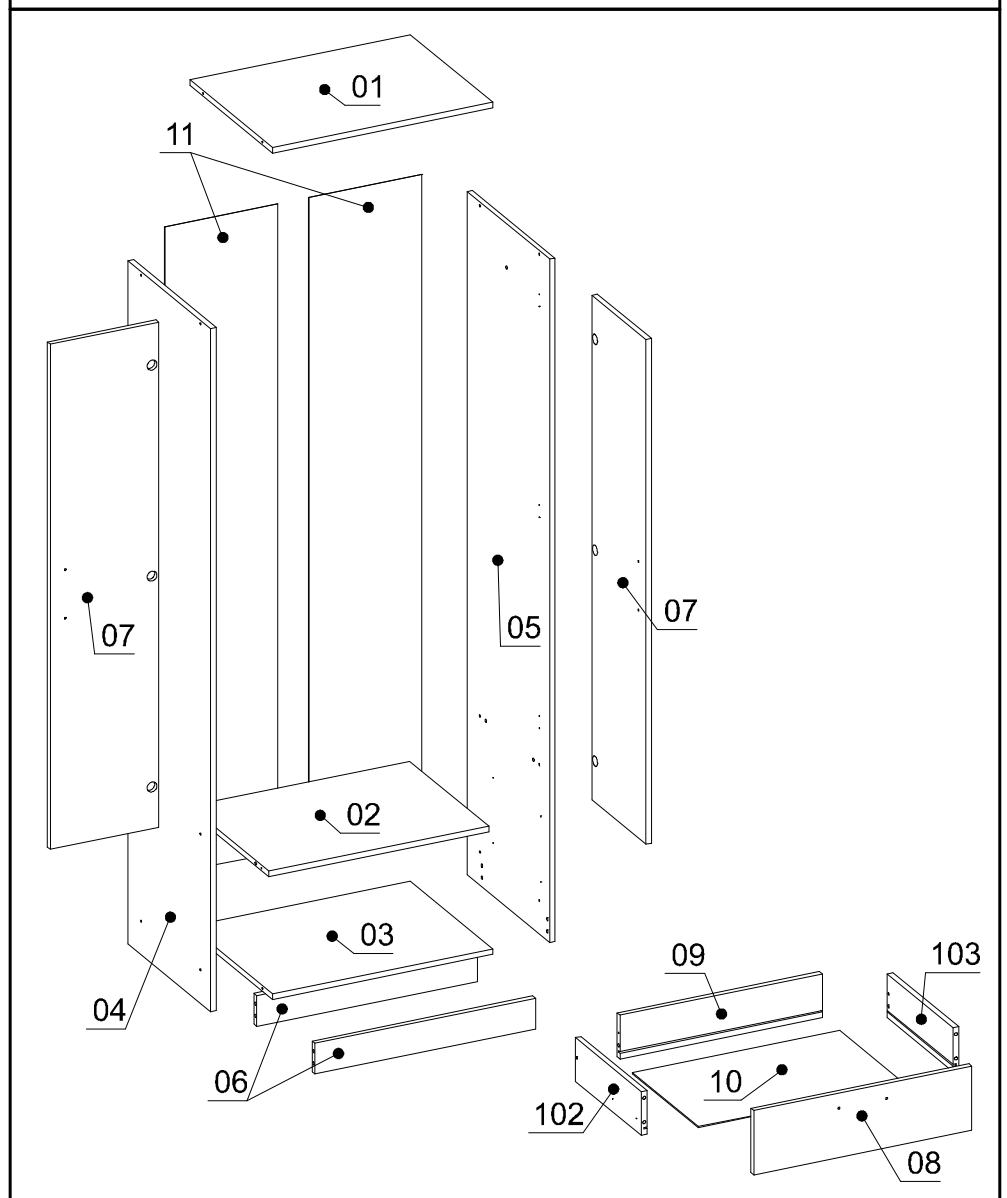

### YOU WILL NEED / VOCÊ VAI PRECISAR DE / USTED NECESITARÁ

Tools not supplied / Ferramentas não fornecidas / Herramientas no incluidas

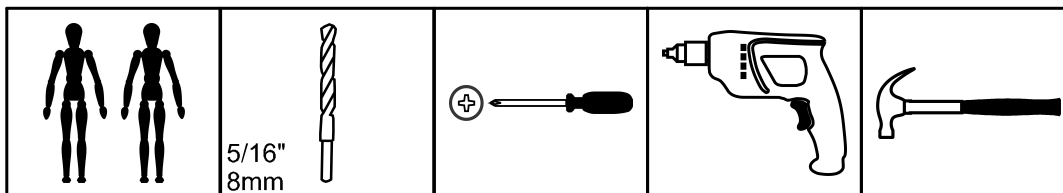

2 People  
2 Pessoas  
2 Personas

5/16"  
8mm  
Drill bit  
Broca  
Taladro

Screwdriver Phillips  
Chave Phillips  
Destornillador cruz

Drill machine  
Furadeira  
Taladro

Hammer  
Martelo  
Martillo











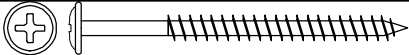



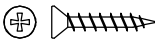





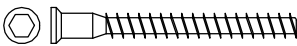

The separation of the accessories before you start the assembly will facilitate the same. In case of doubt on the size of the screws and bolts, use the ruler to bottom of page 3.

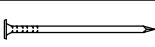
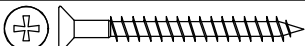
A separação dos acessórios antes de iniciar a montagem facilitará a mesma. Em caso de dúvida no tamanho dos parafusos e cavilhas, utilize a régua ao final da página 3.

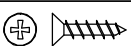
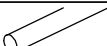
La separación de los accesorios antes de comenzar el armado facilitará el mismo. En caso de duda sobre el tamaño de los tornillos y taquetes, utilice la regla al pie de página 3.

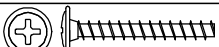
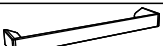
## IDENTIFICATION OF ACCESSORIES IDENTIFICAÇÃO DOS ACESSÓRIOS/ IDENTIFICACIÓN DE ACCESORIOS

A		Flanged head screw / Parafuso flangeado / Tornillo de cabeza flangeada	5,0x60 mm	2
A1		Glue / Cola / Pegamento	13 g	1
A2		Small plastic foot / Sapata redonda / Pie plástico	14 mm	4
A4		Metalic bracket / Cantoneira de metal / Suporte de metal	22x22 mm	8
A6		"H" profile / Perfil "H" / Perfil "H"	-	1
A8		Flat head screw / Parafuso chato / Tornillo de cabeza plana	3,5x20 mm	4
B3		Bushing / Bucha expansiva / Tapón	8x50 mm	2
B8		Shelf bracket / Suporte de prateleira / Suporte de repisa	10x15 mm	2
D5		Hinge shim / Calço dobradiça / Bisagra de calce	-	6
D6		Metal hinge super high / Dobradiça super alta / Bisagra alta	26 mm	6
E		Wooden dowel / Cavilha / Taquete	8x30 mm	24
E9		Strap / Cinta / Correa	-	2
G		Structural screw / Parafuso estrutural / Tornillo estrutural	5,0x50 mm	12
H		Allen key / Chave allen / Liave allen	3 mm	1
I		Structural screw cover/Tampa parafuso estrutural/Tapa tornillo estrutural	-	12
L17		Telescopic slide / Corrediça telescópica / Corredera telescópica	350 mm	4
N		Nail / Prego / Clavo	10x10	52
O		Flat head screw / Parafuso chato / Tornillo de cabeza plana	4,5x45 mm	4
o1		Triangular support / Suporte triangular / Soporte triangular	-	4
P5		Flat head screw / Parafuso chato especial / Tornillo de cabeza plana	3,5x14 mm	2
R4		Laminated plump / Roliço plastificado / Regordete laminado	22 mm	1
S		Pan head screw / Parafuso panela / Tornillo de pan	3,5x14 mm	60
T		Flanged head screw / Parafuso flangeado / Tornillo de cabeza flangeada	3,5x25 mm	8
T12		Handle / Puxador Aleno Fit / Tirador	128 mm	4
Z4		Clothes rack support / Suporte cabideiro / Soporte perchero	-	2

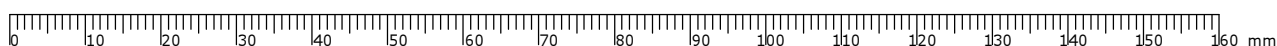

PRE-ASSEMBLE  
PRÉ-MONTAGEM / PRE ARMADO

01

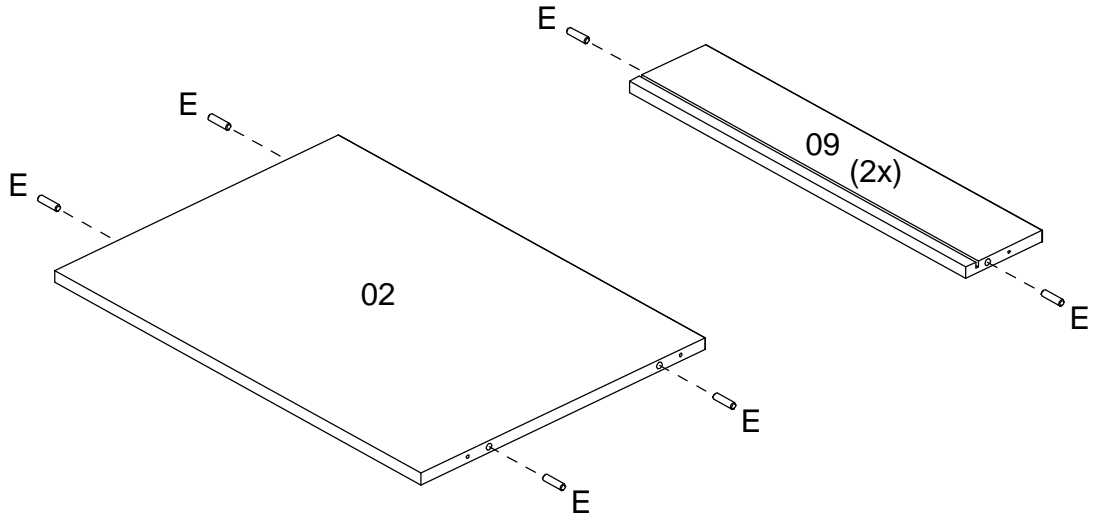
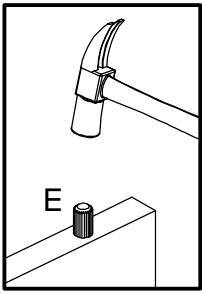

02

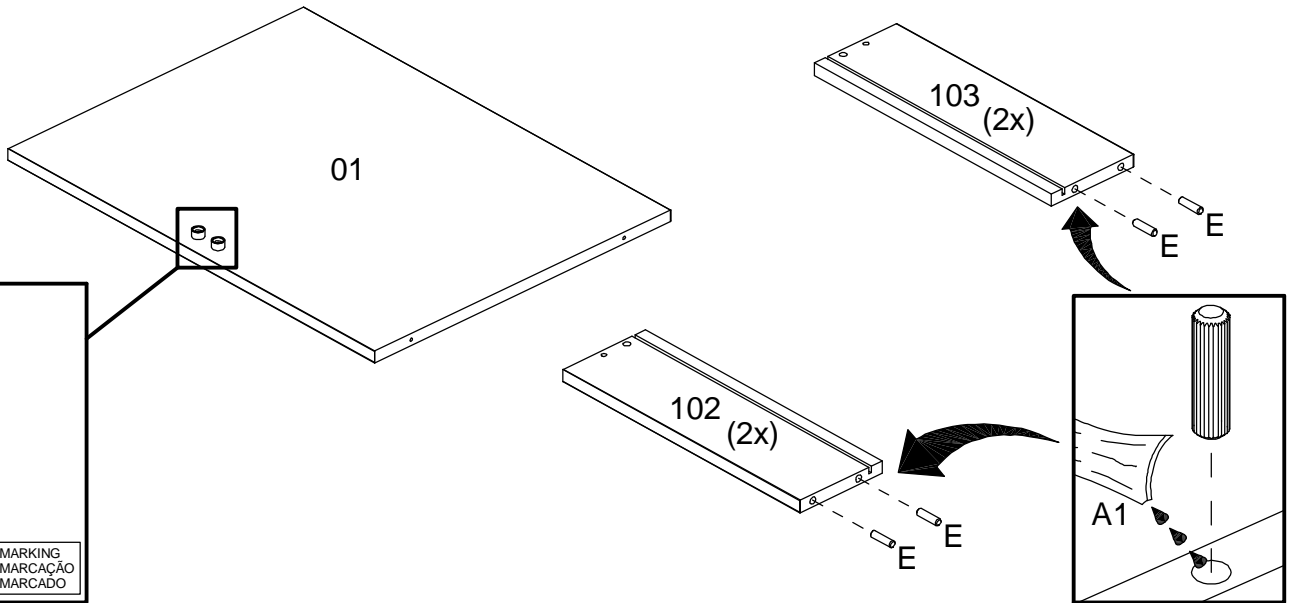
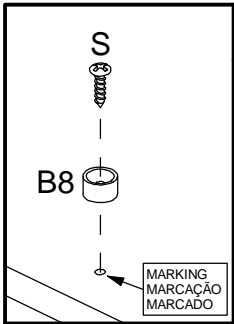

03

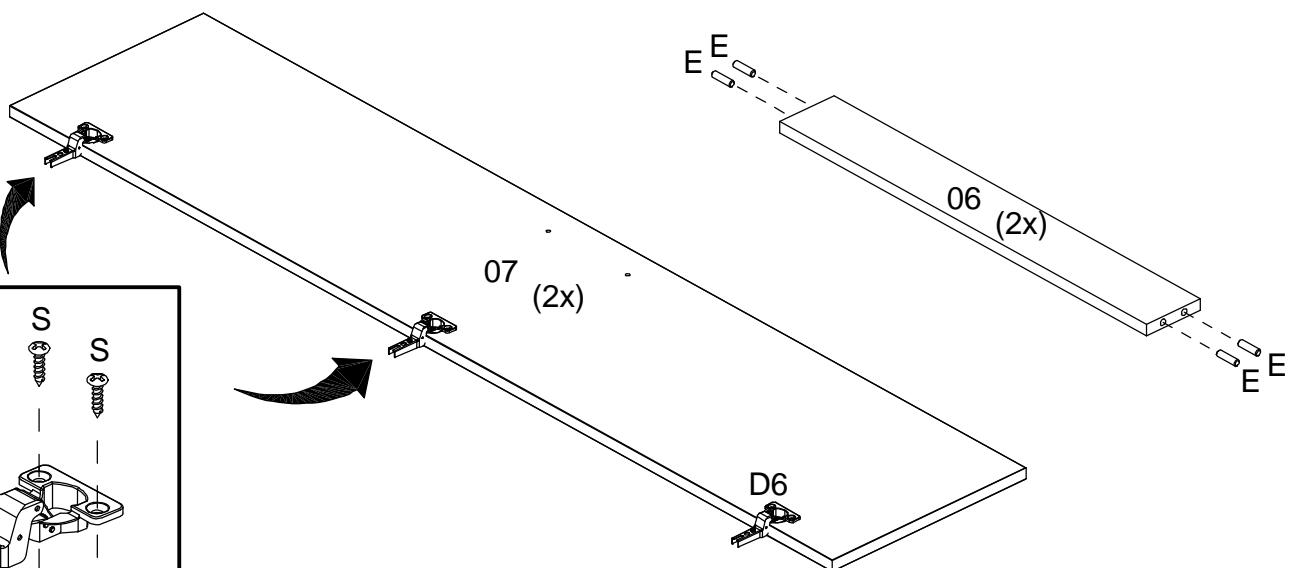
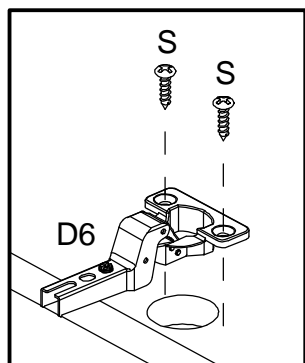

04

SEPARATE THE TWO PARTS OF THE METAL SLIDE TO THE ASSEMBLY FOLLOWING THE INSTRUCTIONS BELOW.  
SEPARARE AS DUAS PARTES DA CORREDIÇA METÁLICA PARA A MONTAGEM SEGUINDO AS INSTRUÇÕES ABAIXO.  
SEPARAR LAS DOS PARTES DE LA CORREDERA DE METAL PARA EL ARMADO Y SEGUIR LAS INSTRUCCIONES ABAJO.

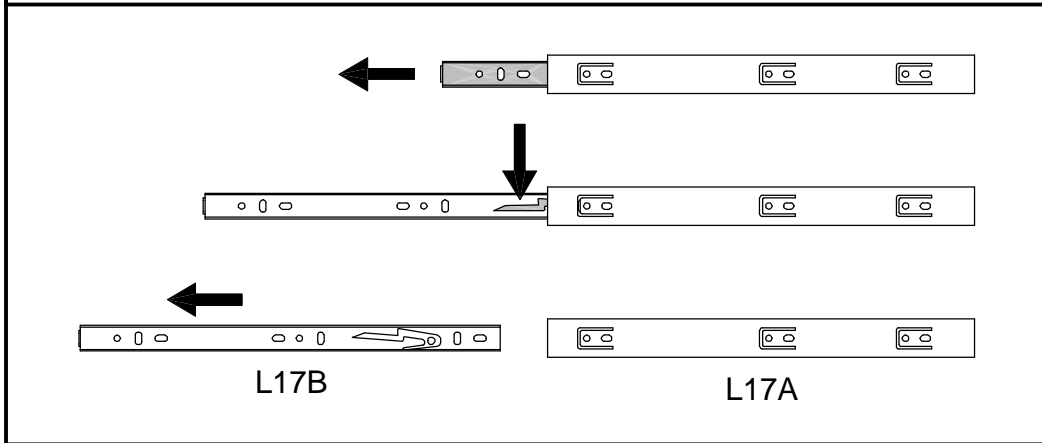

05

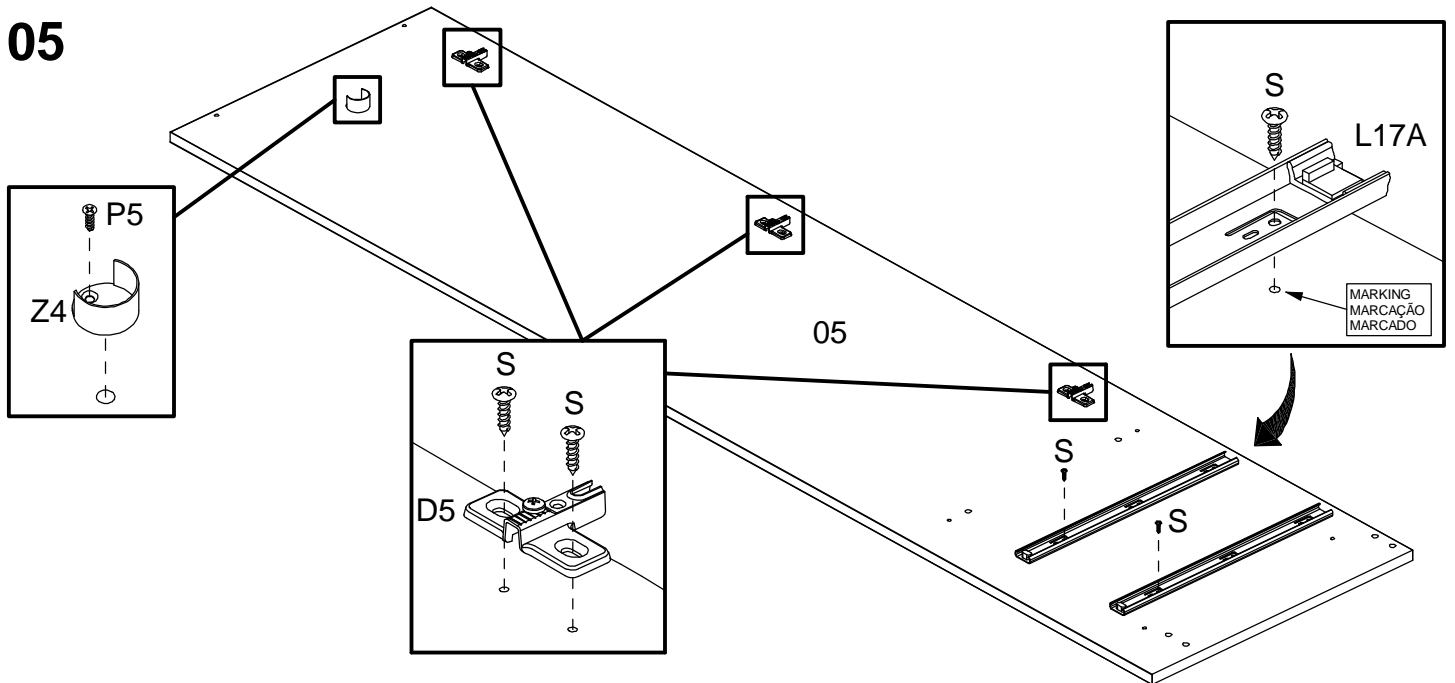

06

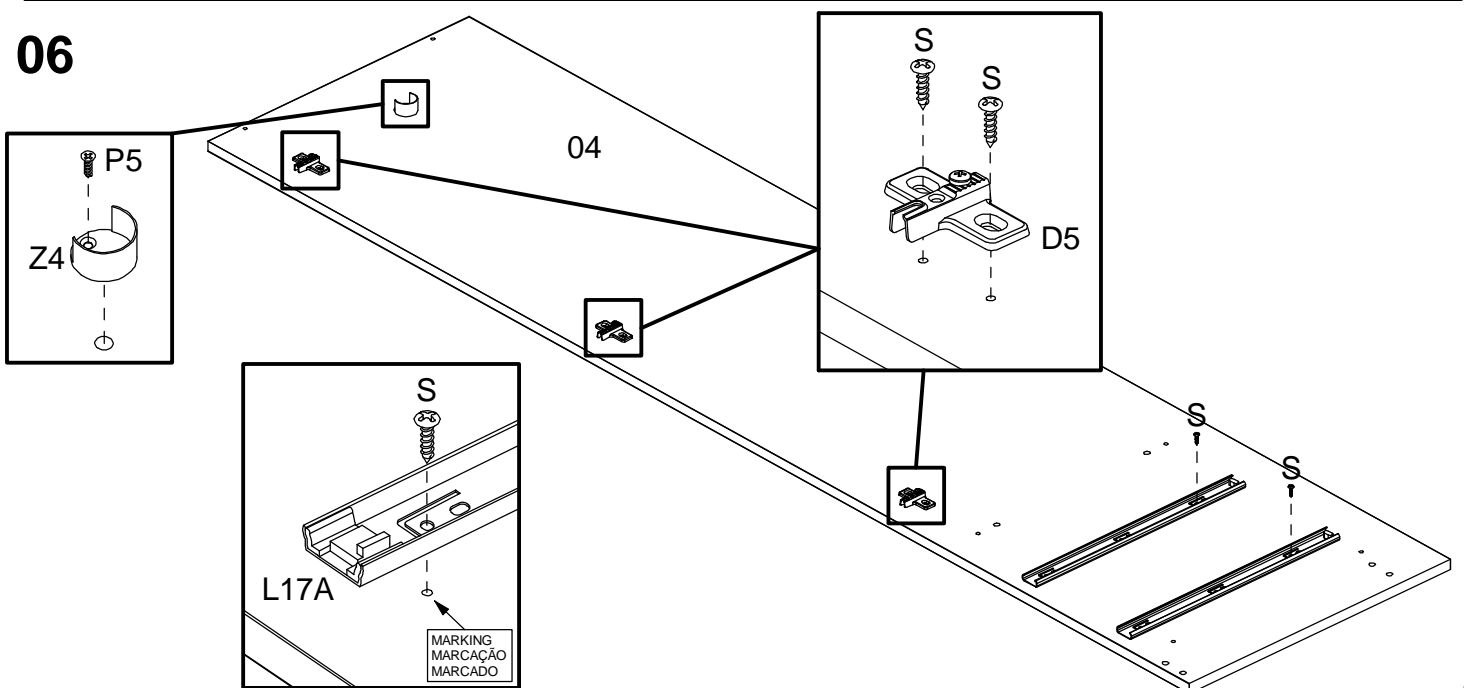

ASSEMBLY  
MONTAGEM / ARMADO

07

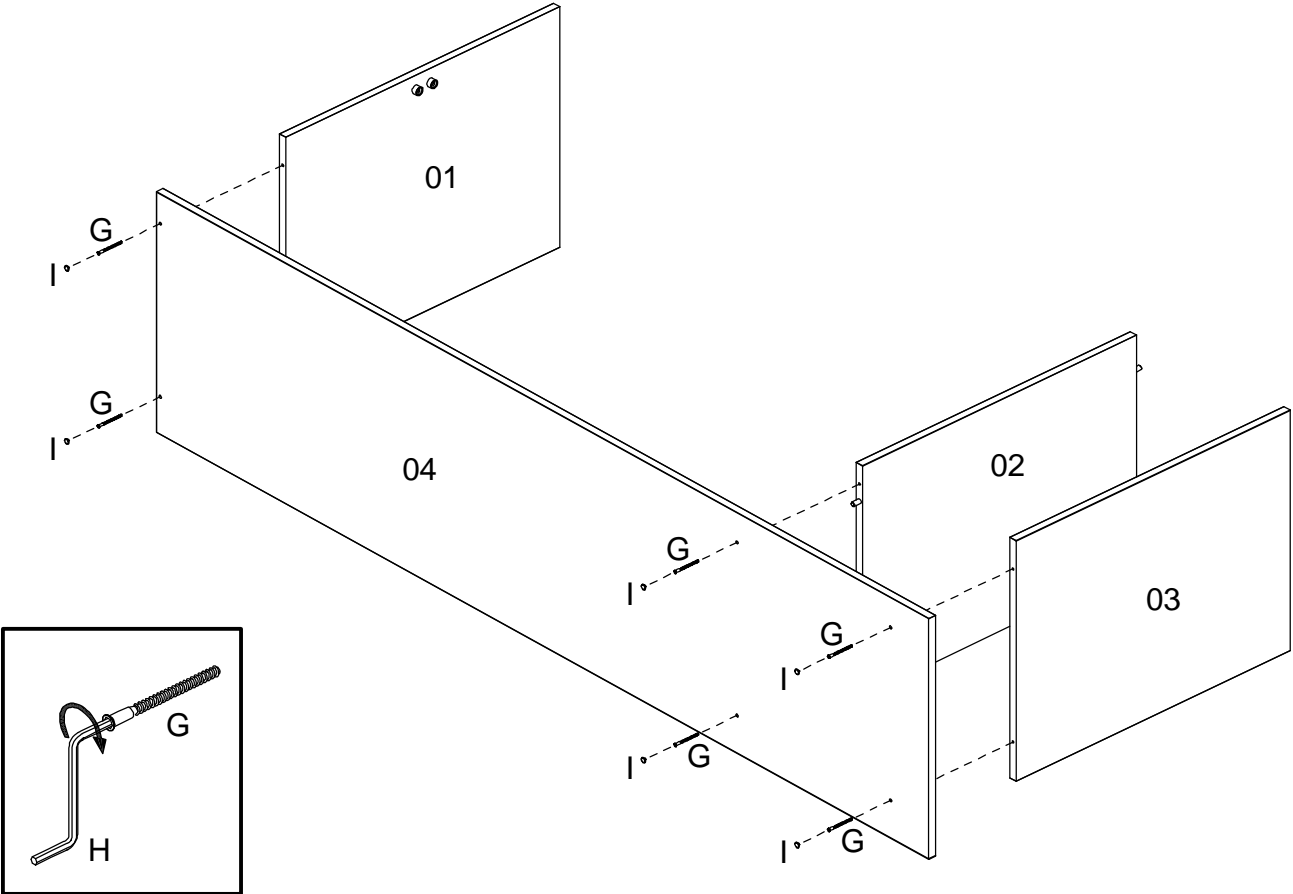

08

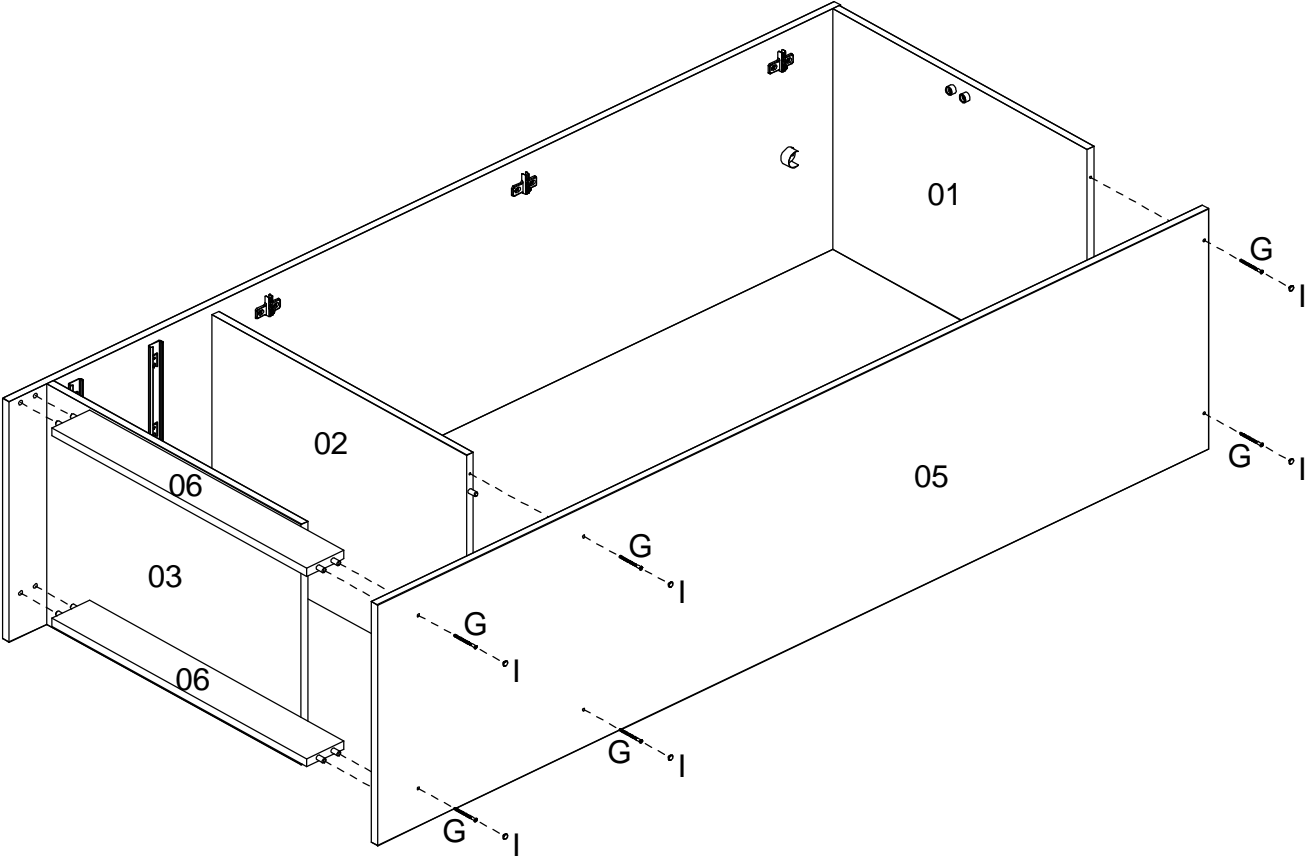

09

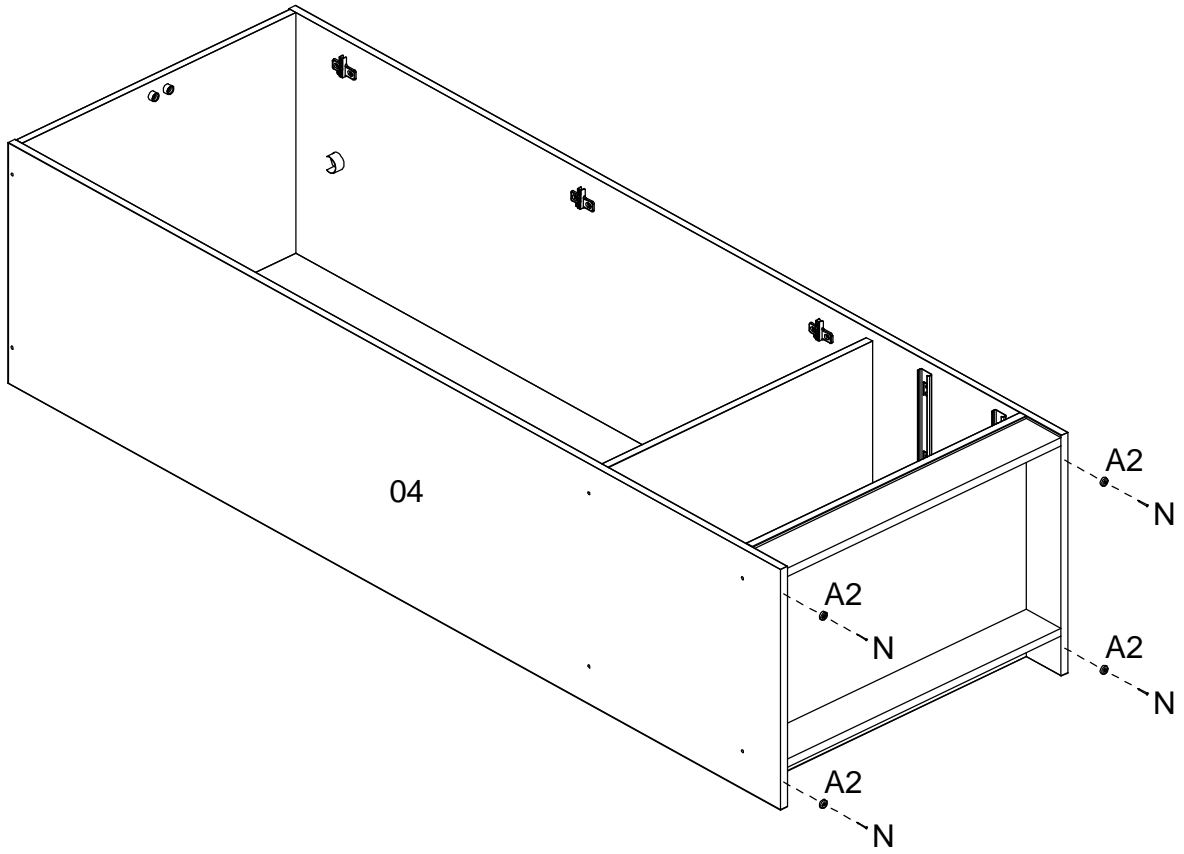

10

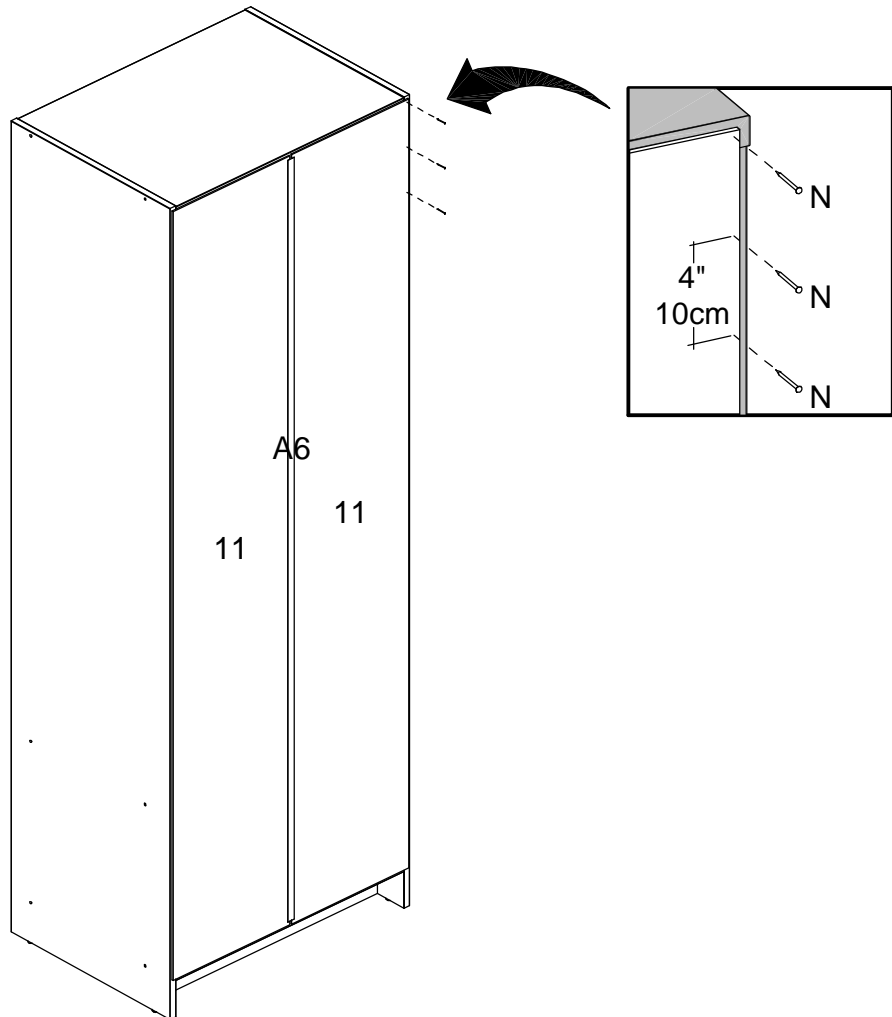

11

TO AVOID ANY INJURY THE FURNITURE MUST BE FIXED ON THE WALL. THANKS.  
PARA EVITAR QUALQUER ACIDENTE, É OBRIGATÓRIO FIXAR O MÓVEL NA PAREDE. OBRIGADO!  
PARA EVITAR CUALQUIER ACCIDENTE ES OBLIGATORIO ANCLAR EL MUEBLE EN LA PARED. GRACIAS

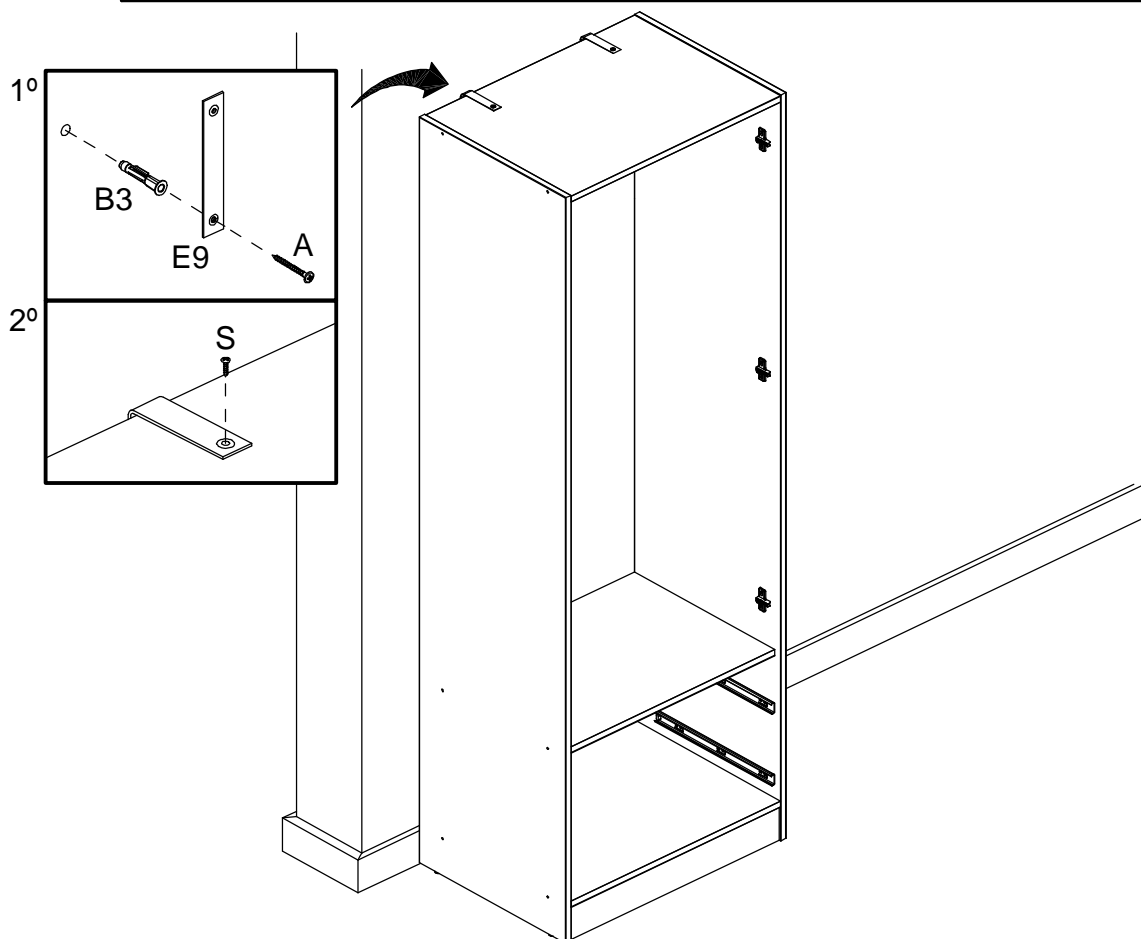

12

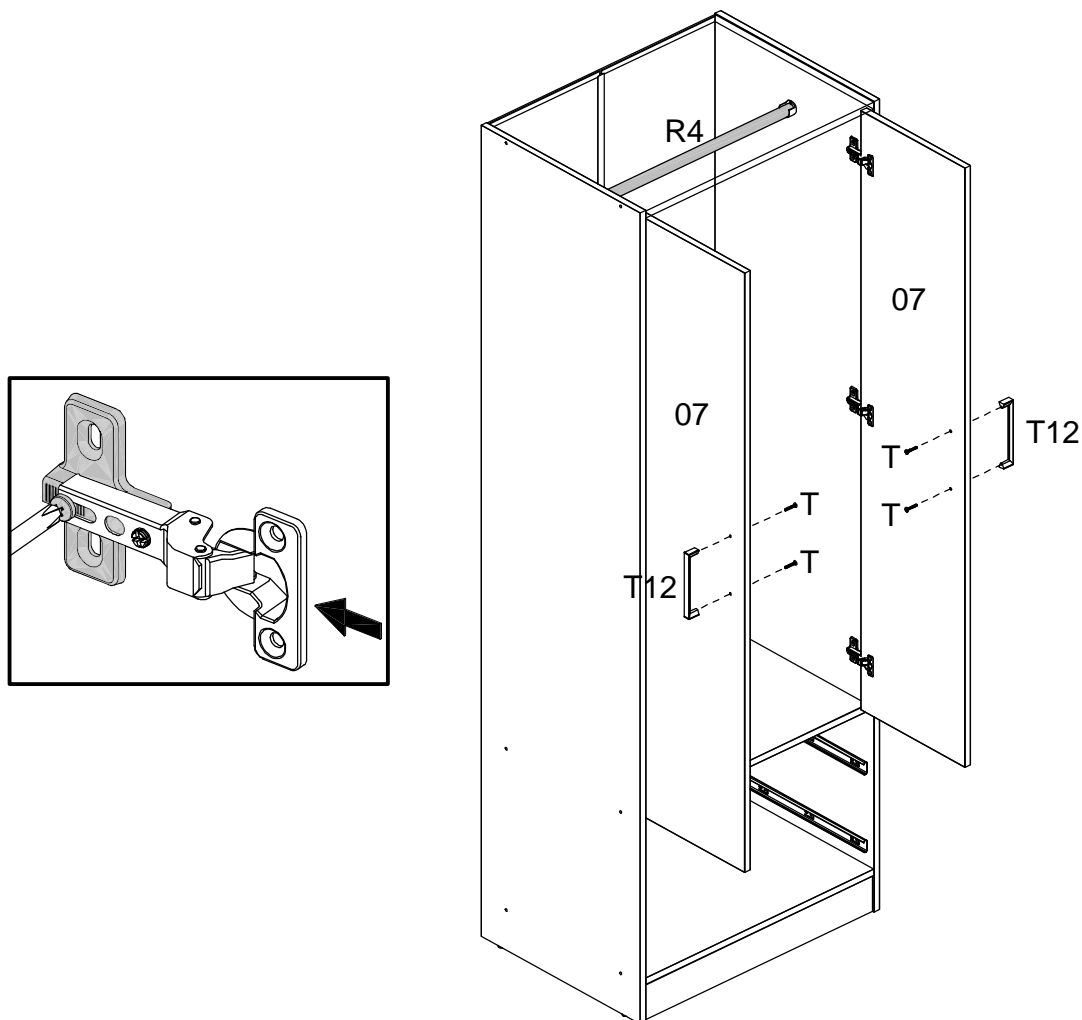



13

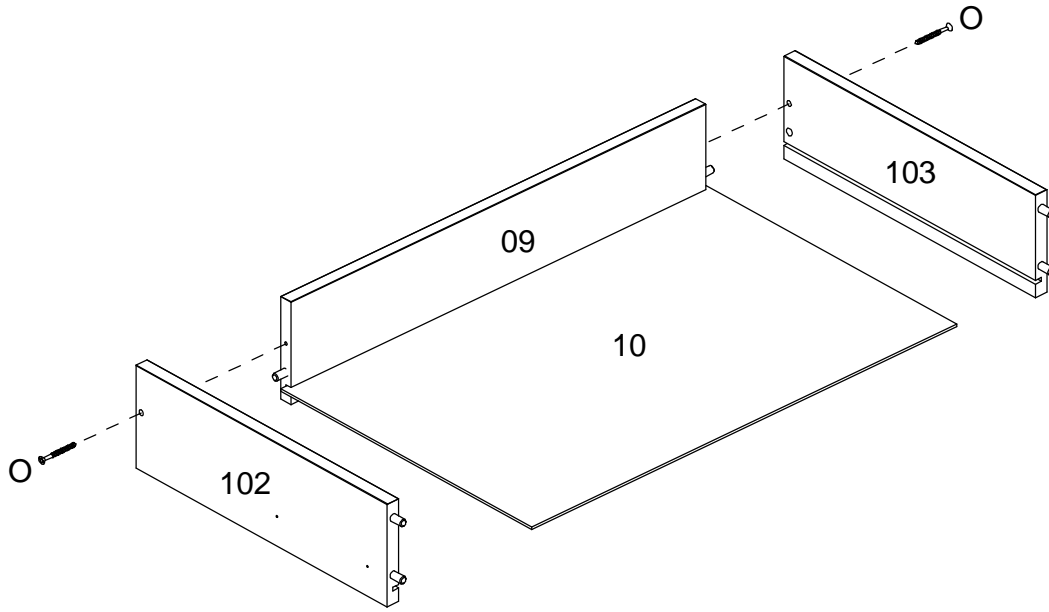

14

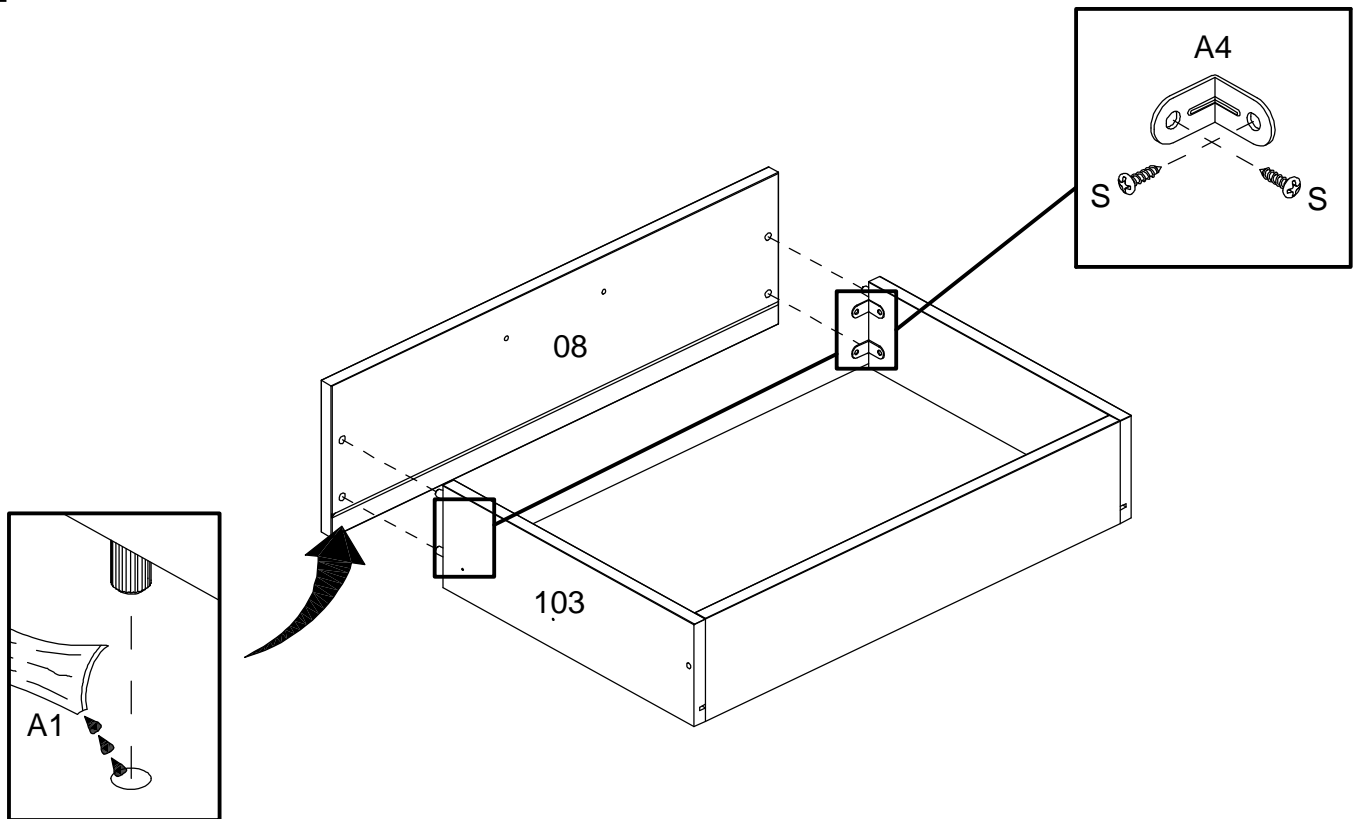

15

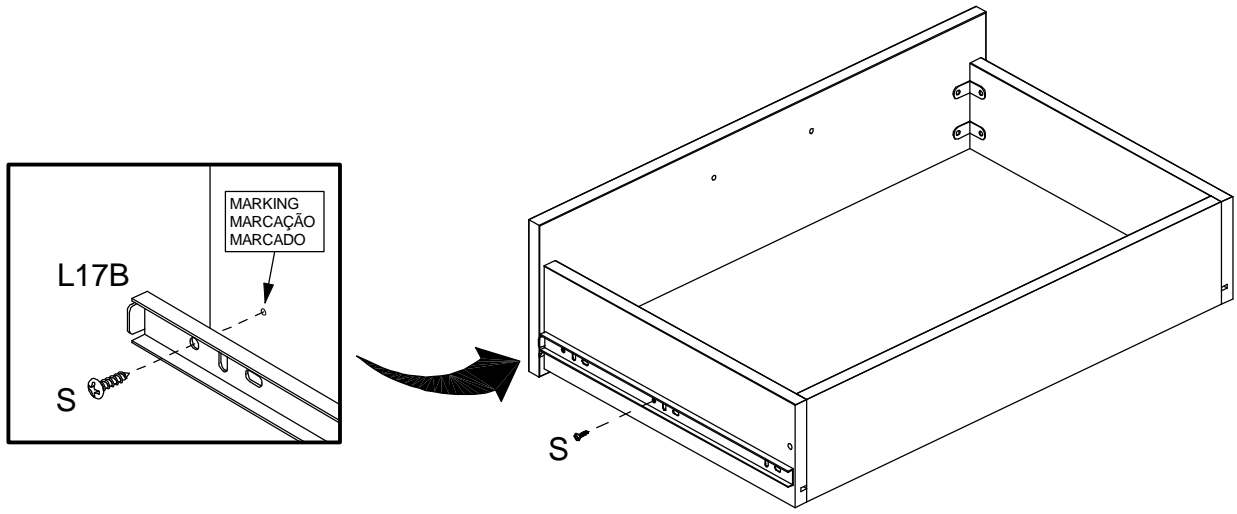

16

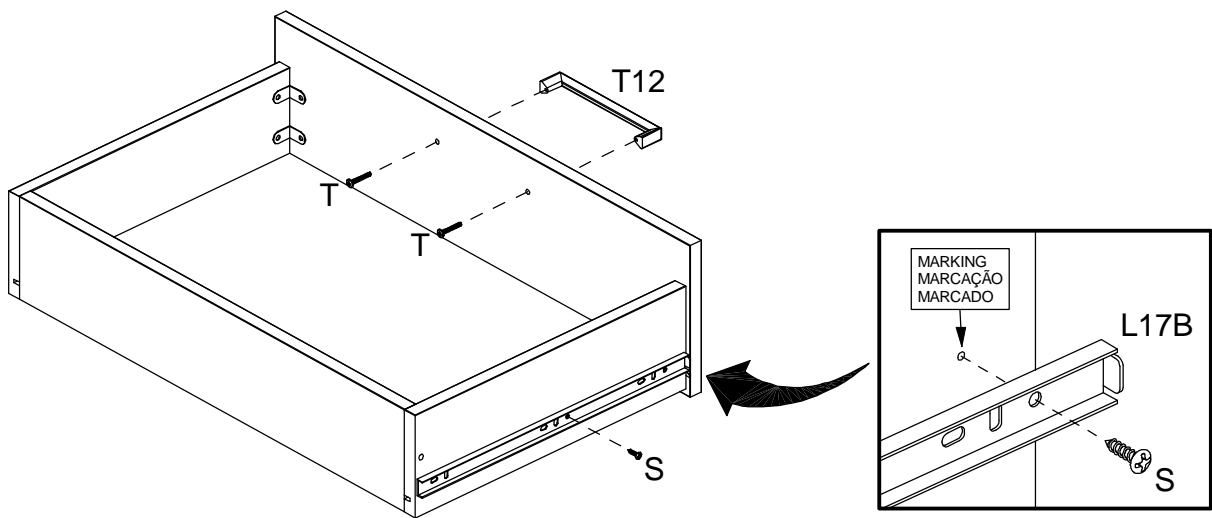

17

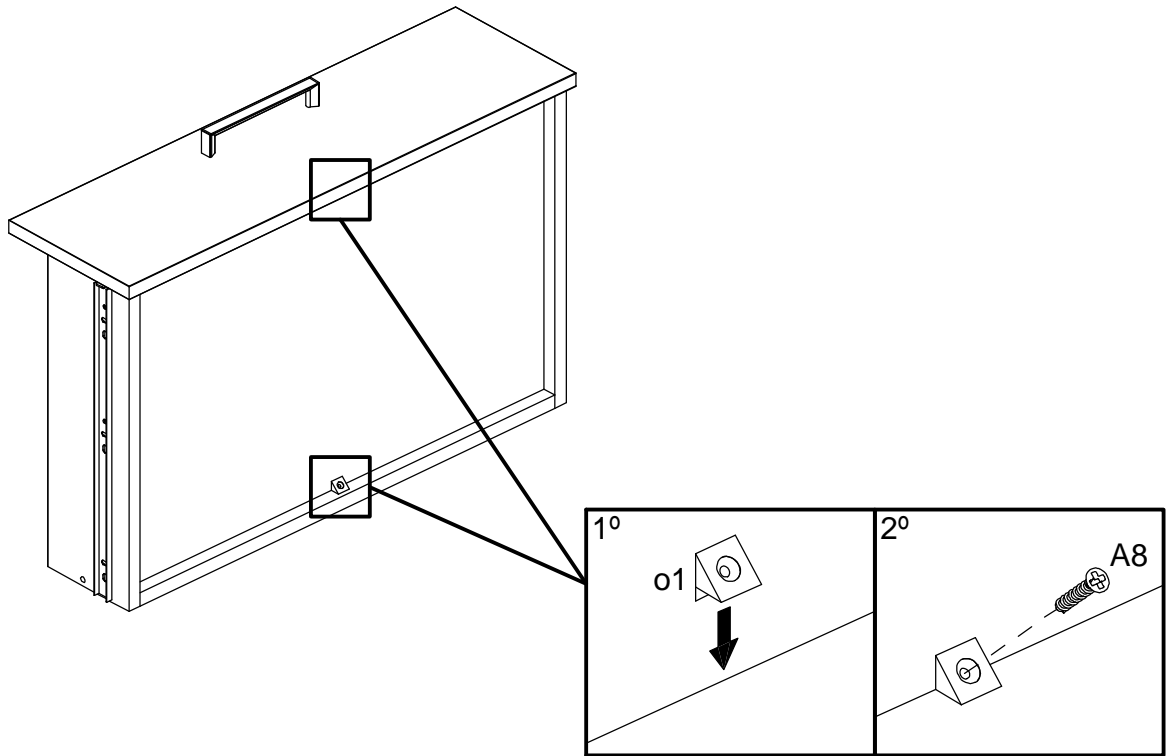

18

