

Cut out this line

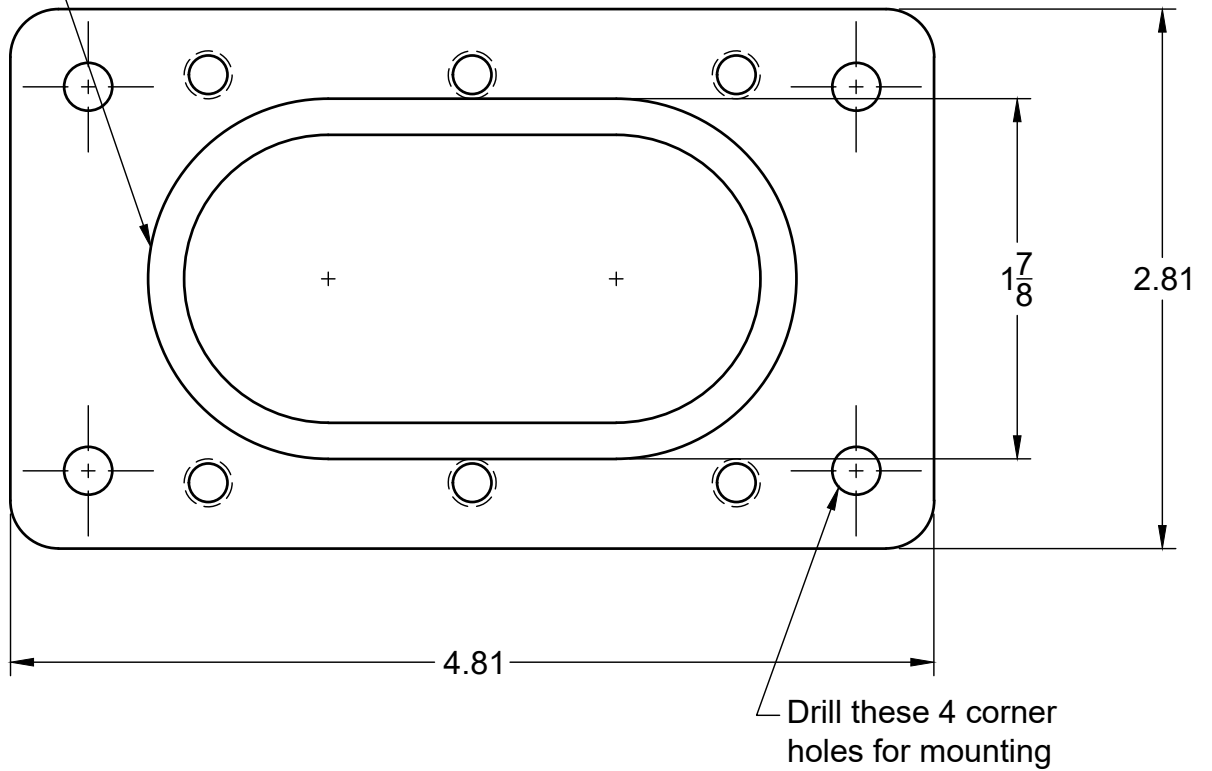

Make sure your printer is set to print at 100% scale and double check the dimensions match the printed size. Mark the centers of the oval and the 4 corner holes using the template and a center punch. Use a $1 \frac{7}{8}$ in hole saw to cut these out and then cut the straight lines between them to make the oval. We recommend an air saw but a Sawzall or cutoff wheel will also work. The 4 corner holes get drilled out to $\frac{5}{16}$ in, we recommend using a step drill for this.

PROJECT

Terminator

TITLE

Gen 2 Terminator Base Template

APPROVED

SIZE

CODE

DWG NO

REV

CHECKED

A

DRAWN

Owen Sharpe

4/4/2022

SCALE 1:1

WEIGHT

SHEET 1/1