



E25

Electric Pallet Jack

Multiple patents pending



CAPACITY 2,500 Lbs.

EASY EXCHANGE LITHIUM ION BATTERY

24-volt 20AH rechargeable
110VAC plug-in external charger

DRIVE AND TRAVEL CONTROLS

24-volt Curtis DC transistor travel control with permanent magnet drive motor.

Variable speed from 0 mph to 2.8 mph empty
Variable speed from 0 mph to 2.5 mph loaded

WEIGHT

288 lbs. with battery

TIRES

Drive (1) 8.3" x 2.8" polyurethane
Load (2) 2.4" x 3.1" polyurethane

FORKS 27" OAW x 45.25" OAL

Designed for use with standard 48" pallets and other common skids and containers. Forks can achieve a maximum elevation of over 7.5" and are shaped at the load wheel housings for pallet entry and exit without need or wearable rollers.

CONTROL HEAD

Travel, lift, and lower functions are located in the ergonomic operator handle. All operator controls are accessible without having to lift one's hand from the loop handle. The control head is designed to allow easy operation with either hand and includes a belly button reversing switch, dual butterfly travel controls, horn, battery discharge indicator and manual lowering control for quick and efficient operation. The low mounted tiller arm offers excellent operator comfort and minimum steering effort.



HYDRAULICS

Permanent magnet DC pump and chrome plated cylinder provide for smooth and efficient lifting.

ELECTRICAL

Water resistant connectors and shrouded wiring harness supply power reliably to components. System includes a key switch, emergency power disconnect and on-board dock for Easy Exchange Battery.

DUTY CYCLE

Revolutionary Easy Exchange Battery delivers up to 3 hours of operation and can be fully charged within 2.5 hours. Optional extra batteries can be purchased to extend run time or to serve as a reliable back-up.



BRAKES

Electromechanical brake provides good stopping power when handle is upright or lowered beyond the operating range.

SERVICEABILITY

Removable covers and modular design of components provides for easy maintenance with simple hand tools. Two piece drive wheel reduces complexity of tire changes.

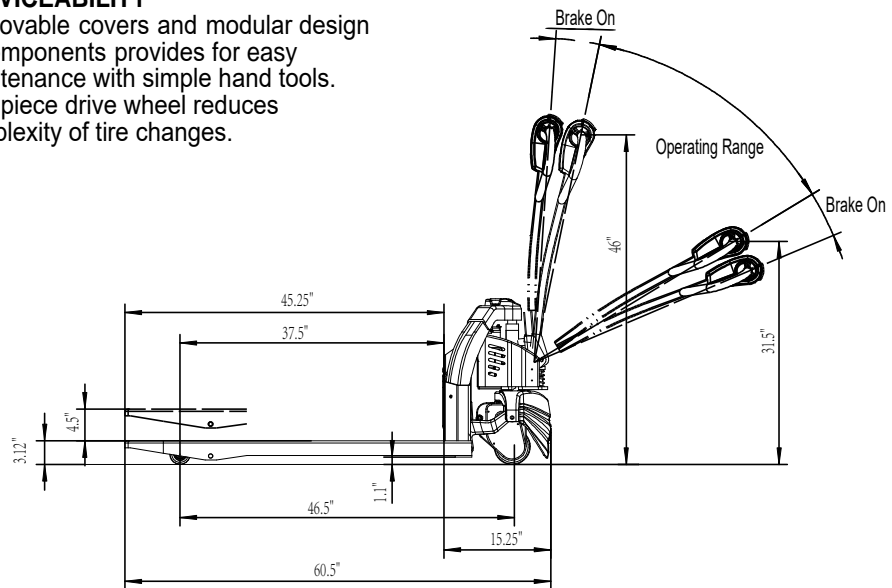
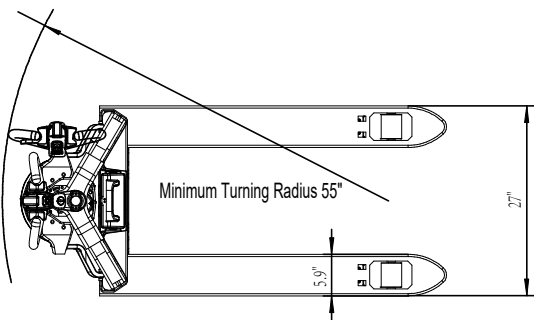

Distributed by Big Lift LLC
www.bigjoeforklifts.com
630-916-2600

Certification
All units are built to be in compliance with the Occupational Safety & Health Act (OSHA)

Big Lift LLC will not assume liability for injuries or damage arising from, or caused by, the removal of any safety devices from their vehicles by user. Because of Big Lift continuing to improve products, specifications are subject to change without notice.

© Copyright 2017, Big Lift LLC Printed USA 0717