

JOEY

ACCESS VEHICLES



+SAFETY -TIME

Joey access vehicles support the ability to bring materials up and down from height and drive from task to task allowing workers to complete elevated work more safely and quickly. Joey access vehicles reduce employer exposure to worker injuries resulting from the use of ladders or other fixed platforms and assist in their compliance with general OSHA regulations. Unlike some lightweight commercial products, the Joey was built from the ground up for the rigors of work, not the soft music of elevators. Point blank, these industrial trucks are highly productive and allow your workers to simply do more and hurt less.

INFINITELY SAFER THAN LADDERS



As anyone who has worked overhead with tools or been confronted with walking down a ladder with their hands full can tell you, ladders are unsafe by nature for many tasks. The steel channel masts on all Joey access vehicles provide exceptional stability for operators while elevated and support best in class load capacity to bring materials, goods, or tools up and down from height. Additionally, fully enclosed operator's compartments, and a host of safety and ergonomic features on Joey series vehicles ensure operators are both confident and comfortable when in use.

2X WORKER PRODUCTIVITY

Joey access vehicles can turn many two person tasks into a one person task, and allow many one person tasks to be done twice as fast. Joeys can move briskly at ground level, while automatically reducing travel speed at height. Precise electronic power steering and the ability to turn around in narrow aisles, make Joey vehicles extremely easy to maneuver from location to location. When compared to other compact units that employ swivel casters, Joeys provide the best operator control, carry the greatest payloads, have the longest duty cycles, and simply outclass the competition in regard to productivity



JOEY ZERO

JO-118

ELECTRIC ACCESS VEHICLE

HUNDREDS OF USES, ZERO EXCUSES



The Zero is a versatile light duty machine for elevated tasks including order picking, shelf stocking, inventory management, and maintenance. A safer and more productive alternative to rolling ladders, the Zero has broad application even in the smallest of spaces in warehouses, commercial buildings, and retail operations due to its rear entry design, low self-weight, and narrow chassis.

BE A HERO WITH THE ZERO.

Compared to competitive machines the ZERO delivers far superior control and productivity which operators will greatly appreciate. First and foremost is the 360-degree steering common to all Joey series vehicles. Most competitive vehicles utilize front casters which are prone to wobble when reorienting and awkwardly pivot vehicles right and left with a toggle. The Zero also comes standard with a powered front load tray and forward-facing blue light to further improve the vehicle's productivity and safety benefits.

Maximum travel speed 4 mph

Minimum turn aisle 70"

Max operator platform height 118"



BEST IN CLASS CONTROLS

Joey series ergonomic power steering and travel controls provide for highly intuitive and accurate operation. Vehicle operation is simple to learn and easy to master.



PERMANENT MAGNET 24V

DC DRIVE MOTOR Powerful neodymium magnets support a highly efficient drive system which is matched to integral AGM batteries and a 110vac smart charger to deliver up to 4 hours of continuous operation on a single charge.



UNIQUE DESIGN FEATURES

The Zero features rear entry and a powered front load tray which when combined with optional rail guidance can allow the vehicle to efficiently operate in high density pick modules.

JOEY

J1-126/162/192

TASK SUPPORT VEHICLE

DRIVE TOW ELEVATE

The market leader in its class, the revolutionary J1 Joey has defined a new generation of industrial trucks built to support diverse and changing equipment needs in modern warehousing, distribution, retail, and manufacturing operations. From ecommerce broken case picking to pharmaceutical cycle counts to bringing parts line side, the compact and versatile J1 Joey delivers like no other. The J1 Joey's ability to effortlessly move from location to location at heights of up to 192", turn around accurately in as little as 72", and optionally tow up to 2,500lbs provides so much utility it is as easy to understand as it is to drive.

SAFE, SIMPLE & SATISFYING

Built as a medium duty truck, the J1 outshines traditional machines that are often too big, make operators uncomfortable and typically have highly awkward controls. The J1 Joey is nimble, highly intuitive to operate, and a joy to drive. Why pick items to a pallet if you don't ship on it? Why have employees surf in thin air on a tether? On the Joey you can pick small items ergonomically to waist level in the security of a fully enclosed operator compartment.

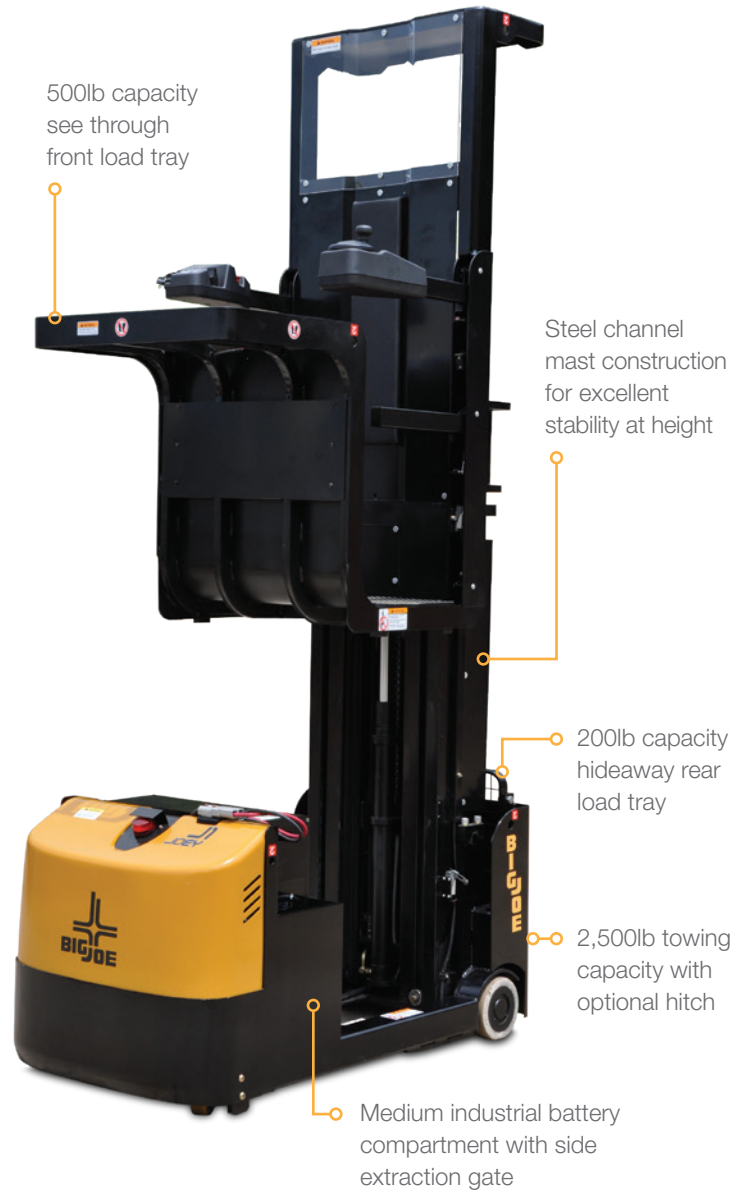

Maximum travel speed 5 mph

Minimum turn aisle 72"

Max operator platform height 192"



BEST IN CLASS CONTROLS

Joey series ergonomic power steering and travel controls provide for highly intuitive and accurate operation. Vehicle operation is simple to learn and easy to master.



MEDIUM DUTY 24V AC DRIVE MOTOR

The J1 is outfitted with an AC powertrain that is both highly efficient and maintenance free making it a dependable performer year after year with travel speeds up to 5 mph.



DASH MOUNTED LCD DISPLAY

Features travel speed settings, battery discharge indicator, hour meter, drive wheel direction indicator and fault code notifications.

SUPER JOEY

J1HD-162/210

HEAVY DUTY TASK SUPPORT VEHICLE

REACH THE NEXT LEVEL

Go higher, faster and longer, while carrying and transporting more in a sleek outfit that just says cool.

With a max operator platform height of 210", and 30% more carrying volume, capacity and travel speed than the standard J1, the Super Joey is ready to challenge trucks designed for the past on their home turf. If your DC or plant runs hard, the Super Joey is here to save the day.

IT JUST WOULDN'T BE THE SUPER JOEY WITHOUT SUPER FEATURES.

In addition to standard J1 Joey capabilities like automatic travel speed reduction during elevation and cornering, advanced LCD display and a high tensile strength unitized steel chassis and mast, the J1HD features a 48volt AC power system, adds high output LED headlights, a premium forward-facing blue light, and is available with an optional lithium-ion battery and charger package. Kapow!

Steel channel mast construction for excellent stability at height

700lb capacity see through front load tray

200lb capacity hideaway rear load tray

3,600lb towing capacity with optional hitch

Large industrial battery compartment with side extraction gate

Maximum travel speed 6.5 mph

Minimum turn aisle 78"

Max operator platform height 210"



BEST IN CLASS CONTROLS

Joey series ergonomic power steering and travel controls provide for highly intuitive and accurate operation. Vehicle operation is simple to learn and easy to master.



HEAVY DUTY 48V AC

DRIVE MOTOR The J1HD is outfitted with a powerful AC powertrain that is highly durable, efficient and maintenance free making it a dependable performer year after year with travel speeds up to 6.5 mph.



DASH MOUNTED LCD

DISPLAY Features travel speed settings, battery discharge indicator, hour meter, drive wheel direction indicator and fault code notifications



ideas @ work

Phone: 630-916-2600

Fax: 630-916-0657

E-mail: sales@bigjoeforklifts.com

Web: www.bigjoeforklifts.com