



J2-144

J2 Joey

Order Pickers

Patents Pending



CAPACITIES

- J2-126, J2-144: 2,000 lbs. @ 24" LC on forks to 126"
- J2-192: 2,200 lbs. @ 24" LC on forks to 144"
- 1,500lb capacity on forks to full heights with 300 lbs. rated operator's compartment

BATTERY INFORMATION

Compartment: 29.1" x 11" x 30"
 Connector: SB-175 Red A-22
 Minimum battery weight 700 lbs.

PERFORMANCE

Maximum Lift Heights

J2-126: 132" platform, 126" forks
 J2-144: 150" platform, 144" forks
 J2-192: 198" platform, 192" forks

Maximum Speeds

Travel: Variable from 0 mph to 4.5 mph at ground level, speeds automatically reduced with increased elevation to slow at max height.

Lift: Up to 32 fpm

WHEELS / TIRES

J2-126, J2-144: 10" x 4" poly drive tire
 J2-192: 10.25" x 5" poly drive tire
 6.5" x 4.7" poly load wheels
 3" x 2" poly stability casters

ELECTRICAL

Dual 24-volt ZAPI COMBI ACO travel and power steering controllers.
 Dual controls for travel facilitates effective operation while in forks forward or forks trailing operator stances. Automatic steering orientation maintains consistent function via laser control sensor.
 LCD dashboard displays hour meter, battery state of charge, travel speed, drive wheel directional indicator, and fault codes.
 AC drive motor provides high torque throughout the entire drive range.
 The brushless design of the AC motors drastically reduces maintenance costs while extending duty cycle. Travel speed remains constant relative to throttle position regardless of the load on truck.

(4) selectable travel speed settings and a global turtle travel speed setting can be used to tailor equipment performance to the experience level of the operator and use.

MAST

Heavy duty I-beam design provides excellent stability at height. Steel mast channels and side mounted lift cylinders increase total vehicle capacity and service life.

CHASSIS

Three point chassis design with along with 180° drive motor steering arc provides exceptional maneuverability. Powerhead mounted stability casters add additional truck stability and operator confidence at working heights.

OPERATOR COMPARTMENT

Ergonomic fingertip control for travel, lift, and lower functions provide the operator with logical intuitive drive characteristics while traveling at elevation or lowered.

The operator compartment is designed for comfort and features a ergonomic floor mat and features a forward and backrest cushion. Retractable compartment side-rails allow for easy egress from either side of the vehicle.

REGENERATIVE BRAKES

Regenerative braking is applied when the operator removes their hand from travel control or when plugging occurs. An electromagnetic parking brake is applied after the truck is stopped.

STANDARD FEATURES

- 42" forks with pallet clamp
- Anchor, operator harness & tether
- Overhead guard
- Non-marking tires
- Rear flashing light
- Battery compartment rollers
- Dual controls for travel to facilitate effective operation in forks forward or forks trailing operator stances.

OPTIONAL EQUIPMENT

- Blue light
- Audible back-up or travel alarm
- Rail guidance
- 12v on-board power supply
- Custom fork lengths
- Support for order picking carts

PRIMARY OPERATOR CONTROLS

Left Hand

Right Hand



360°
Tiller Steering



Travel, Lift, Lower, Key Switch and EPD Controls

Dual control for forks trailing operation stance includes hand sensor that automatically maintains a consistent steering orientation when active.



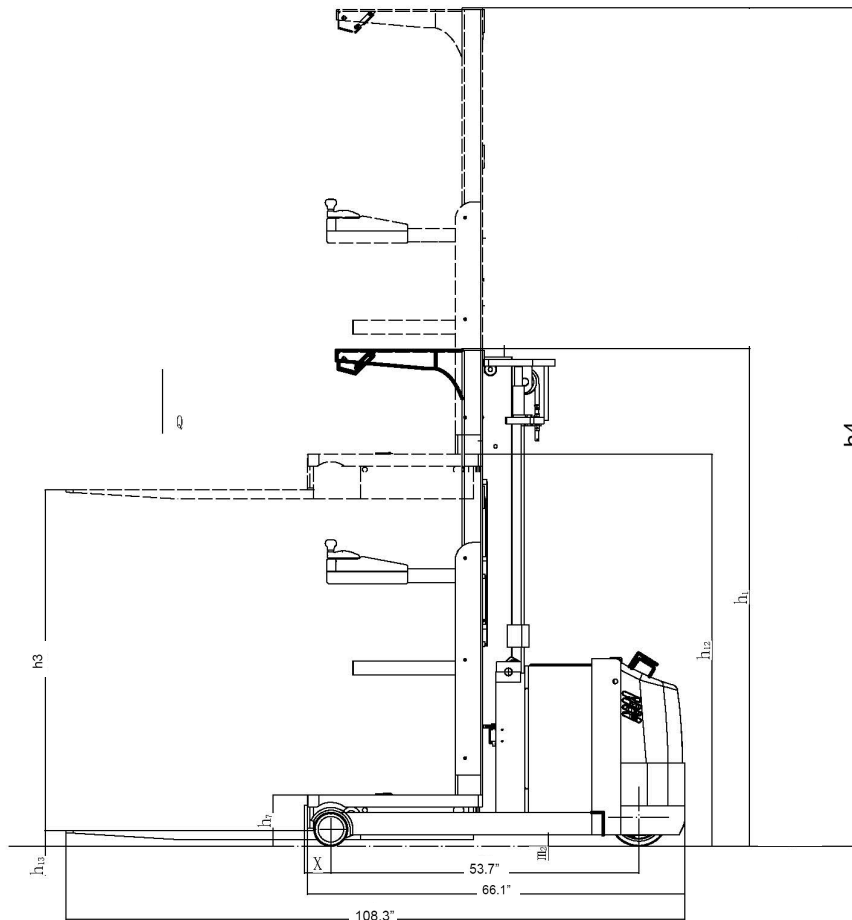

h7 = 8.75" Lowered operator platform height J2-16, J2-144
 h7 = 9.5" Lowered operator platform height J2-192

Wa = 63" Turning radius J2-126, J2-144
 Wa = 65" Turning radius J2-192

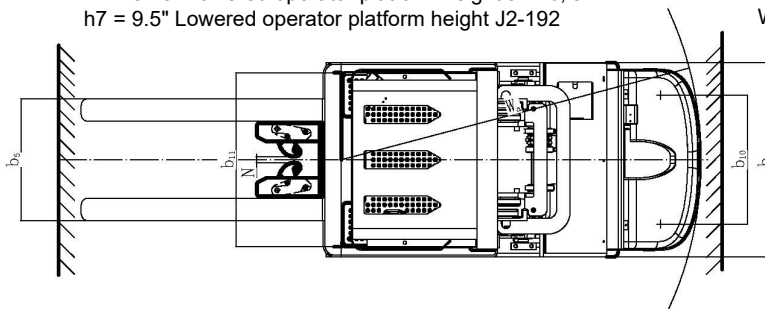

Model #	Mast	Lift Height	Col Height	Extended Height	Overall Width	Overall Length	³ Weight Chassis Only
		h3+h13	h1	h4	b3 / b1	L1	
J2-126	Two Stage	126	89.5	213	34.0	108.3	3500lbs.
J2-144	Two Stage	144	94.0	235	34.0	108.3	3800lbs.
J2-192	Three Stage	192	95.5	295	36.0	116.3	5010lbs.

All measurements in standard "inch" units, for additional specifications or performance details consult factory

³ Estimated shipping weight without battery



Big Lift LLC
 www.bigjoeforklifts.com
 630-916-2600

Big Lift LLC will not assume liability for injuries or damage arising from, or caused by, the removal of any safety devices from their vehicles by user. Because of the Big Lift LLC policy of continuing product improvements, specifications are subject to change without notice.

© Copyright 2023, Big Lift LLC Printed USA 0115