

FORCE USA™

THE TRUSTED NAME IN STRENGTH EQUIPMENT

OWNER'S MANUAL F-DOGSLED

Dog Sled Push and Pull

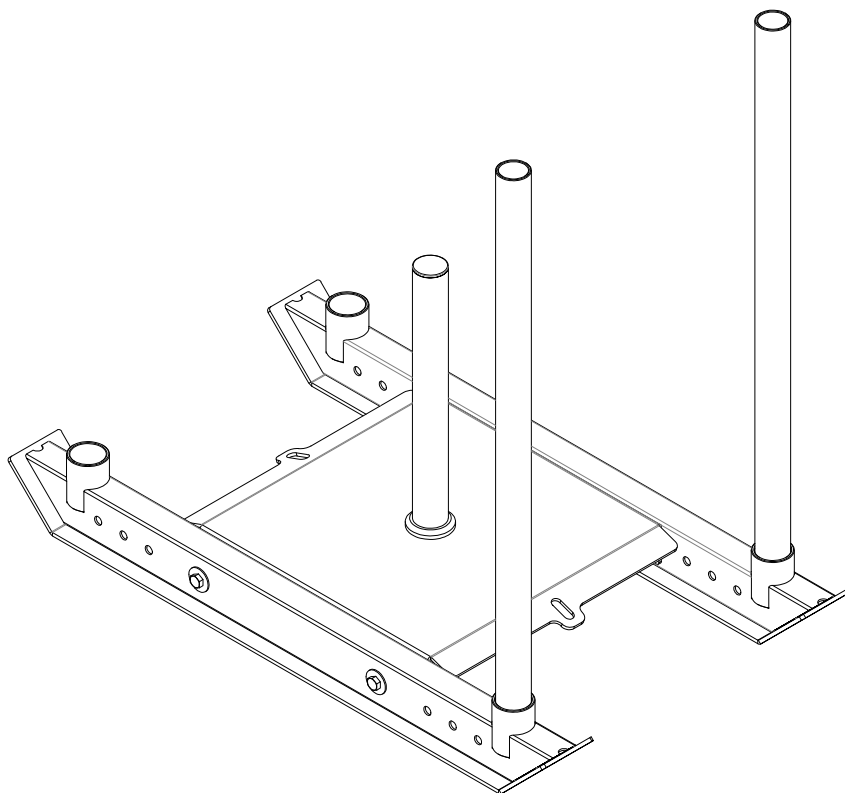

CAUTION!

Read all precautions and instructions in this manual before using this equipment.



**DESIGNED
IN THE USA**



Safety information

Important – Please read fully before assembly or use

This exercise equipment is built for optimum safety. However, certain precautions apply whenever you operate a piece of exercise equipment. Be sure to read the entire manual before you assemble, operate or use this equipment.

Assembly

- The product must be installed on a stable and level surface.
- Assemble the item as close to its final position (in the same room) as possible.
- Make sure you have enough space to layout the parts before starting.
- Keep children and animals away from the exercise area, small parts could pose a choking hazard if swallowed.
- Dispose of all packaging carefully and responsibly.
- Check you have all the components and tools listed in the parts list, bearing in mind that, for ease of assembly, some components are pre-assembled.
- The assembly of this equipment is best carried out by 2 people.

Use

- It is the responsibility of the owner to ensure that all users of this product are properly informed as to how to use this product safely.
- This product is intended for domestic use only.
Do not use in any commercial, rental, or institutional setting.
- Use the equipment only for intended use, as described in this manual. Do not use attachments not recommended by the manufacturer.
- Keep this equipment indoors, away from moisture and dust. Do not put the equipment in a garage, outbuilding, covered patio, or near water.
- Your product is intended for use in clean dry conditions. You should avoid storage in excessively cold or damp places as this may lead to corrosion and other related problems that are outside our control.
- Keep unsupervised children away from the equipment.
- Parents and others in charge of children should be aware of their responsibility because the natural play

instinct and the fondness of experimenting of children can lead to situations and behavior for which the training equipment is not intended.

- If children are allowed to use the equipment under supervision, their mental and physical development should be taken into account. They should be controlled and instructed to the correct use of the equipment. The equipment is under no circumstances suitable as a toy.
- Disabled persons should not use the equipment without a qualified person or doctor in attendance.

This product is not suitable for therapeutic purposes.

- Always wear appropriate workout clothing when exercising. **Do not** wear loose or baggy clothing, as it may get caught in the equipment. Wear trainers to protect your feet while exercising.
- **Do not** place any sharp objects around the equipment.
- Keep hands away from all moving parts.
- If any of the adjustment devices are left projecting, they could interfere with the user's movement.
- Before using the equipment to exercise, always perform stretching exercises to properly warm up.
- Only one person at a time should use the equipment.
- A spotter is recommended during exercise.
- If the user experiences dizziness, nausea, chest pain, or other abnormal symptoms **stop the workout and seek immediate medical attention.**
- Injuries to health may result from incorrect or excessive training.
- This product is suitable for a maximum user weight of: **110kg.**
- The maximum training weight loading on barbell support is **120kg**(Including bar and weights).
- This product conforms to: (BS EN ISO 20957-1, EN957-2 and EN957-4) class (H) - Home Use - Class (C).



Warning: Before beginning any exercise program, consult your Doctor. This is especially important for persons over the age of 35 or persons with pre-existing health problems. You **MUST** read all instructions before using any fitness equipment. we and associates assumes no responsibility for personal injury or property damage sustained by or through the use of this product.

Components - Parts

Please check you have all parts listed below

Note: Some of the smaller components may be pre-fitted to larger components. Please check carefully before contacting us regarding any missing components.

Total mass of the product is 46 kg. Total size of the equipment is (width) 100cm × (depth) 61 cm × (height) 103 cm.

1

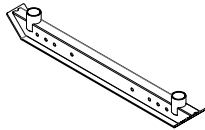

x 2

2

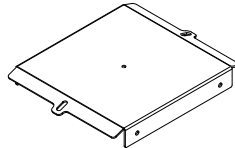

x 1

3

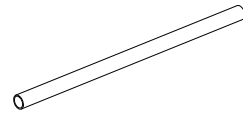

x 2

4

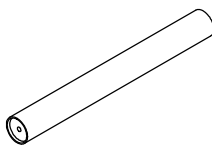

Weight Plate Post x 1

5

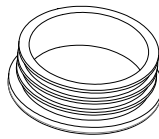

Ø50 End Cap x 1

6

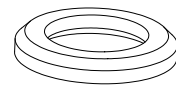





Rubber Cushion x 1

Components - Fixings

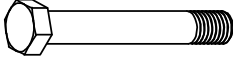
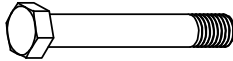
Please check you have all parts listed below

Note: The quantities below are the correct amount to complete the assembly. In some cases more hardware may be supplied than are required. Some of the fixings are pre-fitted to the larger components. Please check carefully before contacting us regarding any missing fixings.

7  M12 x 70 bolt x 4	8  M10 x 50 bolt x 1	9  Ø12 Washer x 4
10  Ø10 Washer x 1	11  Ø12 Big Washer x 4	12  M12 NUT x 4

Ruler - Use this ruler to help correctly identify the hardware



Assembly Instructions

STEP 1

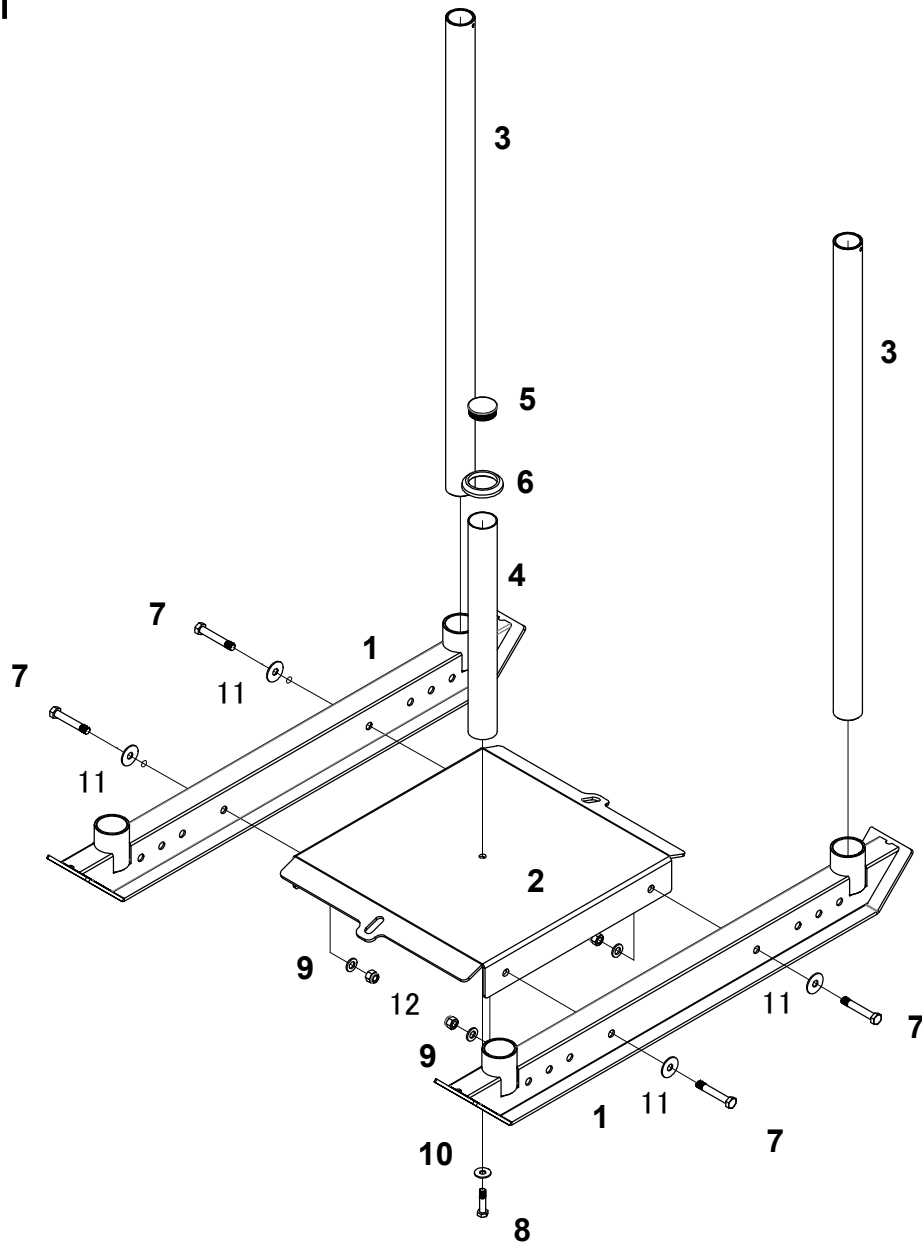

Step 1

a.

Notes: Part (5) is pre-fitted.

Exercise Information

Before starting

Tailor your exercise program according to your physical condition. If you have been inactive for several years, or are overweight, you must start slowly and increase your time on the equipment; a few minutes per workout increase is advisable.

Initially, you may be able to exercise only for a few minutes in your target zone, however, your aerobic fitness will improve over the next six to eight weeks. Don't be discouraged if it takes longer. It's important to work at your own pace.

Please remember these essentials:

- Have your doctor review your training and diet programs to advise you of a workout routine you should adopt.
- Begin your training program slowly with realistic goals.
- Monitor your pulse frequently. Establish your target heart rate based on your age and condition.
- Set up your equipment on a flat even surface with adequate training area, as prescribed in this manual.

Exercise intensity

To maximize the benefits of exercising, it is important to exercise at an appropriate intensity. The intensity level can be found by using your heart rate as a guide. For effective aerobic exercise, your heart rate should be maintained at a level between 65% and 85% of your maximum heart rate as you exercise. This is known as your target zone. You can find your target zone in the table below.

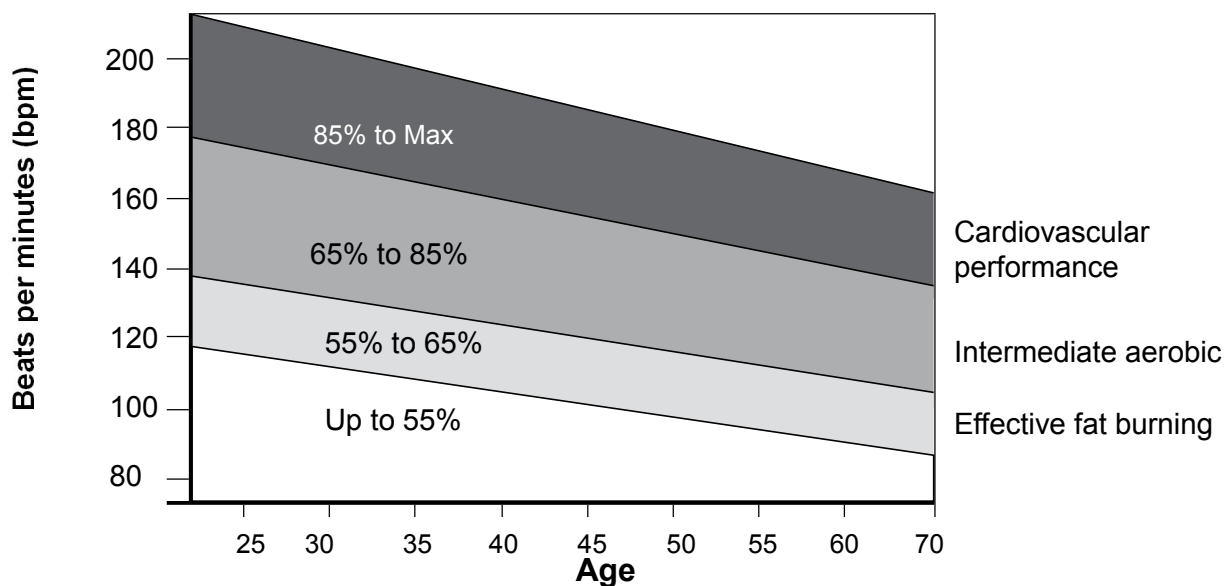

During the first few months of your exercise program, keep your heart rate near the low end of your target zone as you exercise. After a few months, your heart rate can be increased gradually until it is near the middle of your target zone as you exercise.

To measure your heart rate, stop exercising but continue moving your legs or walking around and place two fingers on your wrist. Take a six-second heartbeat count and multiply the results by 10 to find your heart rate. For example, if your six-second heartbeat count is 14, your heart rate is 140 beats per minute. (A six-second count is used because your heart rate will drop rapidly when you stop exercising.) Adjust the intensity of your exercise until your heart rate is at the required level.

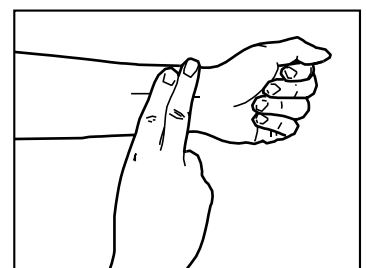

Exercise Information

Muscle Chart

Aerobic Exercise

Aerobic exercise improves the fitness of your lungs and heart - your body's most important muscle. Aerobic exercise is promoted by any activity that uses your large muscles (arms, legs, or buttock, for example).

Weight Training

Along with aerobic exercising which helps get rid of and keep off the excess fat that our bodies can store, weight training is an essential part of an exercise routine. Weight training helps tone, build and strengthen muscle. If you are working above your target zone, you may want to do a lower number of reps.

Targeted Muscle Groups

The exercise routine that is performed on the home gym will develop combined total body muscle groups. These muscle groups are highlighted on the muscle chart below.

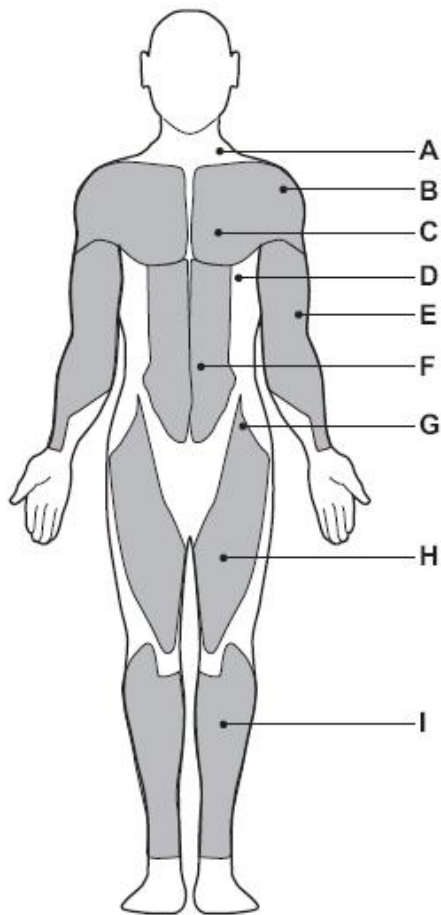

Front

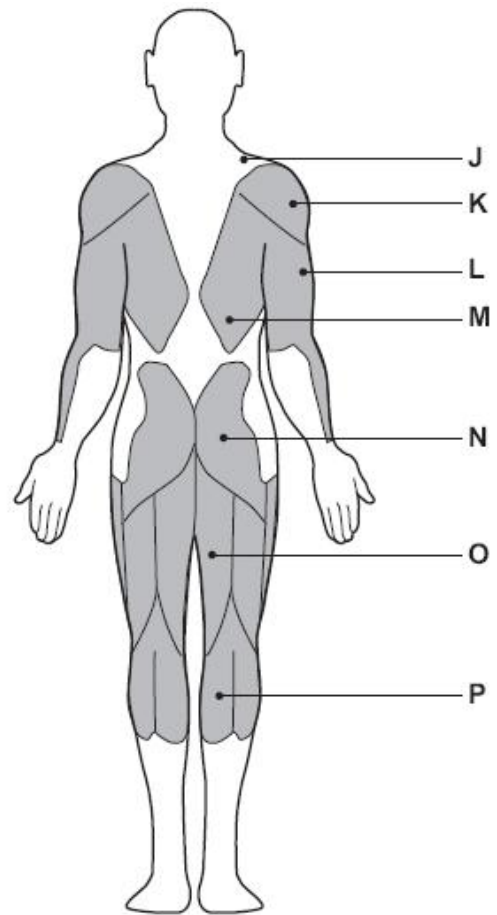

Back

A: Trapezius
B: Anterior Deltoid
C: Pectoralis Major
D: Serratus Anterior

E: Biceps
F: Abdominal
G: Sartorius
H: Quadriceps

I: Tibialis Anterior
J: Trapezius
K: Posterior Deltoid
L: Triceps

M: Latissimus Dorsi
N: Gluteals
O: Hamstrings
P: Gastrocnemius

Exercise Information

Warming up and Cooling down

Each workout should include the following three parts:

1. A warm-up, consisting of 5 to 10 minutes of stretching and light exercise. A proper warm-up increases your body temperature, heart rate, and circulation in preparation for exercise.
2. Training zone exercise, consisting of 20 to 30 minutes of exercising with your heart rate in your training zone. (**Note:** During the first few weeks of your exercise program, do not keep your heart rate in your training zone for longer than 20 minutes.)
3. A cool-down, with 5 to 10 minutes of stretching. This will increase the flexibility of your muscles and will help to reduce post-exercise muscle soreness.

Exercise Frequency

To maintain or improve your fitness, plan three workouts each week, with at least one day of rest between workouts. After a few months of regular exercise, you may complete up to five workouts each week, if desired. Remember, the key to success is make exercise a regular and enjoyable part of your everyday life.

Toe touch stretch

Stand with your knees bent slightly and slowly bend forward from your hips. Allow your back and shoulders to relax as you reach down towards your toes as far as possible.

Hold for 15 counts, then relax

Repeat 3 times.

Stretches: Hamstrings, back of knees and back.

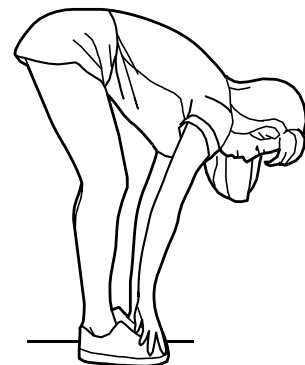

Hamstring stretch

Sit with one leg extended. Bring the sole of the opposite foot toward you and rest it against the inner thigh of your extended leg. Reach towards your toes as far as possible.

Hold for 15 counts, and then relax.

Repeat 3 times for each leg.

Stretches: Hamstrings, lower back and groin.

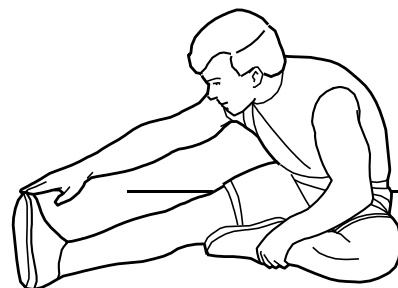

Exercise Information

Calf/Achilles stretch

With one leg in front of the other, reach forward and place your hands against a wall. Keep your back leg straight and your back foot flat on the floor. Bend your front leg, lean forward and move your hips toward the wall.

Hold for 15 counts, then relax.

Repeat 3 times for each leg. To cause further stretching of the Achilles tendons, bend your back leg as well.

Stretches: Calves, Achilles tendons and ankles.

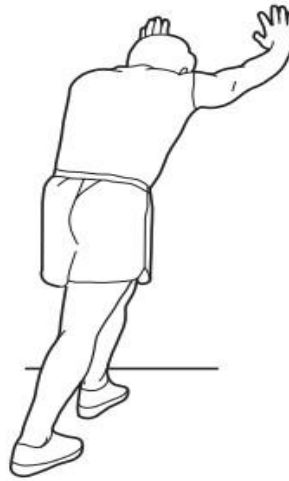

Quadriceps stretch

With one hand against the wall for balance, reach back and grasp one foot with your other hand. Keeping your bent knee pointing directly down towards the floor, gently pull your heel towards your buttock until you feel a gentle stretch in the target area.

Hold for 15 counts, and then relax.

Repeat 3 times for each leg.

Stretches: Quadriceps and Hip muscles.



Inner thigh stretch

Sit with the soles of your feet together and your knees outwards. Pull your feet towards your groin area as far as possible, and push your knee down towards the ground.

Hold for 15 counts, and then relax.

Repeat 3 times.

Stretches: Quadriceps and Hip muscles.



Care and Maintenance

1. The safety level of the equipment can only be maintained if it is examined regularly for damage and wear e.g. ropes, pulleys and connection points.

2. Lubricate moving parts with light oil periodically to prevent premature wear.

3. Inspect and tighten all parts before using the equipment.

Replace defective components immediately and/or keep the equipment out of use until repair. Pay special attention to components most susceptible to wear.

4. The equipment can be cleaned using a damp cloth and mild non-abrasive detergent. **Do not** use solvents.

5. Do not attempt to repair this equipment yourself. Should you have any difficulty with assembly, operation or use of your exercise product or if you think that you may have parts missing, contact the agent.

Guarantee:

For guarantee purposes, please retain your purchase receipt.