



# singing machine®

creating Joy through music™

## SMC2040

INSTRUCTION MANUAL/  
MANUAL DE INSTRUCCIONES/  
MODE D'EMPLOI

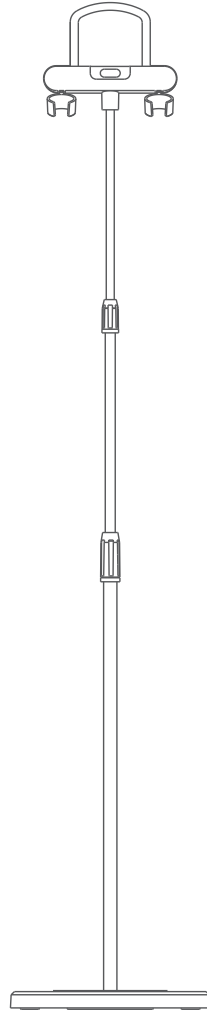
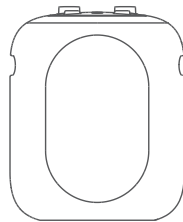



[www.singingmachine.com](http://www.singingmachine.com)

The Singing Machine® is a registered trademark of The Singing Machine Co., Inc.

The Singing Machine® es marca registrada de The Singing Machine Co., Inc.

The Singing Machine® est une marque déposée de The Singing Machine Co., Inc.

# Warnings

	<b>CAUTION</b> RISK OF ELECTRIC SHOCK DO NOT OPEN	
<b>CAUTION:</b> TO REDUCE THE RISK OF ELECTRIC SHOCK, DO NOT REMOVE COVER (OR BACK). NO USER-SERVICEABLE PARTS INSIDE. REFER SERVICING TO QUALIFIED SERVICE PERSONNEL.		

**FCC WARNING:** This equipment may generate or use radio frequency energy. Changes or modifications to this equipment may cause harmful interference unless the modifications are expressly approved in the instruction manual. The user could lose the authority to operate this equipment if an unauthorized change or modification is made.

This device complies with part 15 of the FCC Rules. Operation is subject to the following two conditions: (1) This device may not cause harmful interference, and (2) this device must accept any interference received, including interference that may cause undesired operation.

**NOTE:** This equipment has been tested and found to comply with the limits for a Class B digital device, pursuant to part 15 of the FCC Rules. These limits are designed to provide reasonable protection against harmful interference in a residential installation. This equipment generates, uses and can radiate radio frequency energy and, if not installed and used in accordance with the instructions, may cause harmful interference to radio communications. However, there is no guarantee that interference will not occur in a particular installation. If this equipment does cause harmful interference to radio or television reception, which can be determined by turning the equipment off and on, the user is encouraged to try to correct the interference by one or more of the following measures:

- Reorient or relocate the receiving antenna.
  - Increase the separation between the equipment and receiver.
  - Connect the equipment into an outlet on a circuit different from that to which the receiver is connected.
  - Consult the dealer or an experienced radio/TV technician for help.
- The rating information is located at the bottom of the unit.

**WARNING:** Changes or modifications to this unit not expressly approved by the party responsible for compliance could void the user's authority to operate the equipment.



**DANGEROUS VOLTAGE:** The lightning flash with arrowhead symbol within an equilateral triangle is intended to alert the user to the presence of uninsulated dangerous voltage within the product's enclosure that may be of sufficient magnitude to constitute a risk of electric shock to persons.



**ATTENTION:** The exclamation point within an equilateral triangle is intended to alert the user to the presence of important operating and maintenance (servicing) instructions in the literature accompanying this product.

**DRIPPING WARNING:** This product shall not be exposed to dripping or splashing, and no objects filled with liquids, such as vases, shall be placed on the product.

**VENTILATION WARNING:** The normal ventilation of the product shall not be impeded for intended use.

**CAUTION:** TO PREVENT ELECTRIC SHOCK, MATCH WIDE BLADE OF PLUG TO WIDE SLOT AND FULLY INSERT.

**WARNING:** TO PREVENT FIRE OR SHOCK HAZARD, DO NOT EXPOSE THIS UNIT TO RAIN OR MOISTURE.

## Important Safety Information

1. Read these Instructions.
2. Keep these Instructions.
3. Heed all Warnings.
4. Follow all Instructions.
5. Do not use this apparatus near water.
6. Clean only with a dry cloth.
7. Do not block any of the ventilation openings. Install in accordance with the Manufacturer's instructions.
8. Do not install near any heat sources such as radiators, heat registers, stoves, or other apparatus (including amplifiers) that produce heat.
9. Do not defeat the safety purpose of the polarized or grounding-type plug. A polarized plug has two blades with one wider than the other. A grounding type plug has two blades and a third grounding prong. The wide blade or the third prong are provided for your safety. When the provided plug does not fit into your outlet, consult an electrician for replacement of the obsolete outlet.
10. Protect the power cord from being walked on or pinched particularly at plugs, convenience receptacles, and the point where they exit from the apparatus.
11. Only use attachments/accessories specified by the manufacturer.
12. Use only with a cart, stand, tripod, bracket, or table specified by the manufacturer, or sold with the apparatus. When a cart is used, use caution when moving the cart/apparatus combination to avoid injury from tip-over.
13. Unplug this apparatus during lightning storms or when unused for long periods of time.
14. Refer all servicing to qualified service personnel. Servicing is required when the apparatus has been damaged in any way, such as power-supply cord or plug is damaged, liquid has been spilled or objects have fallen into the apparatus, the apparatus has been exposed to rain or moisture, does not operate normally, or has been dropped.
15. **WARNING:** To reduce the risk of fire or electric shock, do not expose this apparatus to rain or moisture. Do not place objects filled with water, such as a vase, on the apparatus.
16. The AC mains plug is used as the power disconnect device and it should remain readily accessible and operable during intended use. In order to completely disconnect the apparatus from power, the mains plug should be completely removed from the AC outlet socket.
17. **CAUTION:** To reduce the risk of fire or explosion, do not expose batteries to excessive heat such as sunshine, fire or other heat sources.

PORTABLE CART WARNING  
(symbol provided by RETAC)



# Included

Please make sure that the following items are included.

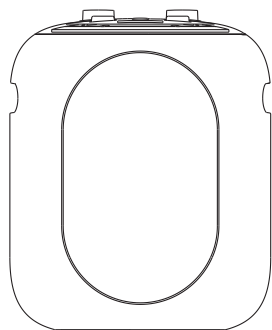

Main Unit

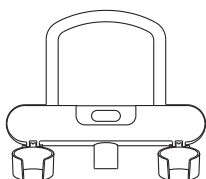

Cradle with mic holders  
(Detachable)



Extendable Mic stand

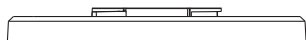

Base

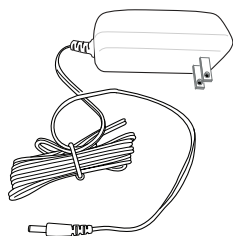

AC Adapter

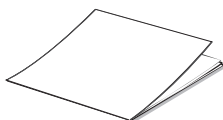

Manual

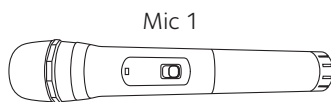

Mic 1

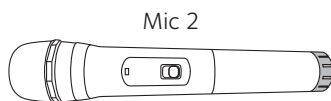

Mic 2

Wireless Microphone

# Assembly

Not for use with other microphone stands. Only lift unit from bottom base. Use caution when placing larger-sized devices in holder.

## All-in-one assembly

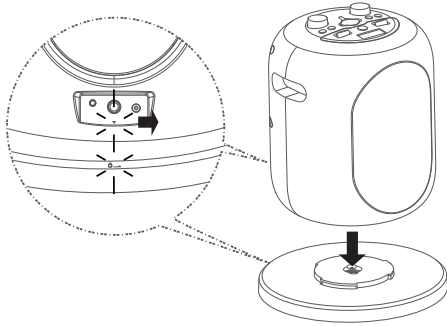

- 1 Insert and rotate clockwise to tighten the Main unit onto the Base.

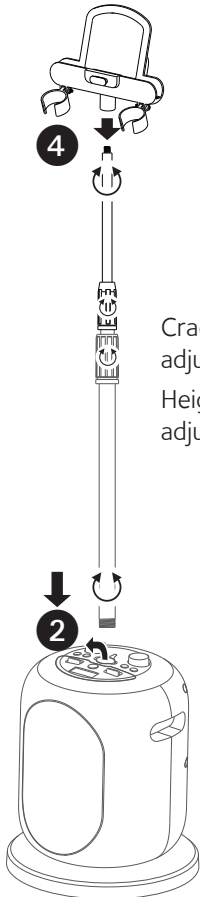

- 2 Lift the rubber cover on the top of the Main unit. Insert the Mic stand into the Main unit and tighten it.

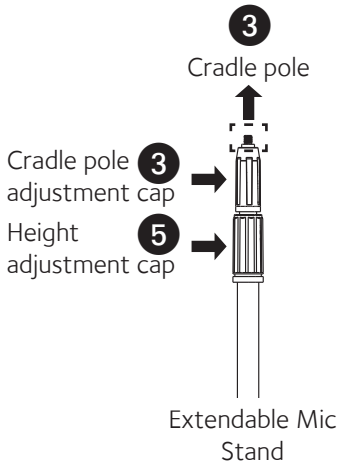

- 3 Untighten cradle pole cap, pull up on the cradle pole. Retighten cap to keep in place.

- 4 Insert then rotate to tighten the Cradle with Mic holders on the mic stand.

- 5 Untighten height adjustment cap to adjust to a suitable height. Retighten cap to hold in place

# Assembly

## Split type assembly

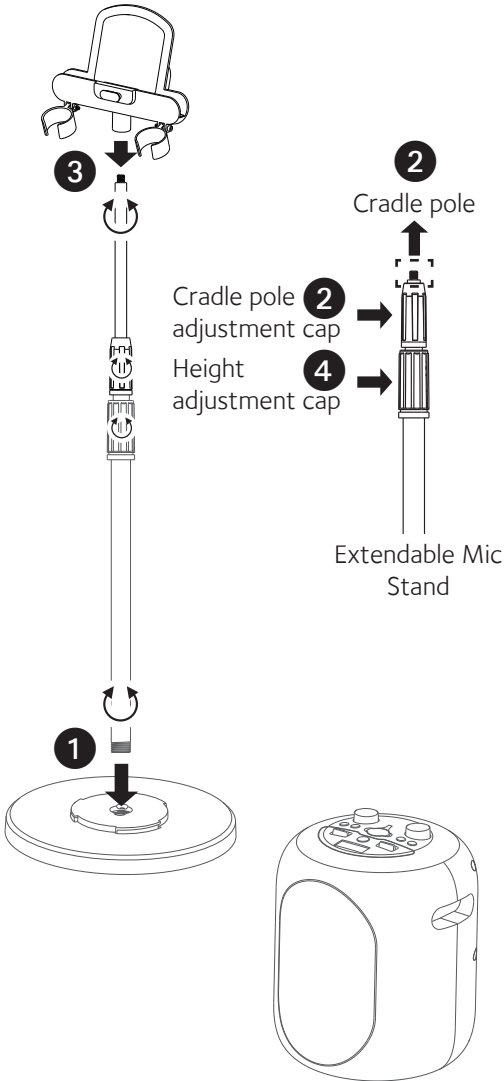

- 1 Insert the Mic stand into the Base and tighten it.
  - 2 Untighten cradle pole cap, pull up on the cradle pole. Retighten cap to keep in place.
  - 3 Insert then rotate to tighten the Cradle with Mic holders on the mic stand.
  - 4 Untighten height adjustment cap to adjust to a suitable height. Retighten cap to hold in place
  - 5 Leave the main unit within 30 feet/10 meters distance as a speaker.
- NOTE:** Always remember to put the rubber cover back in place.

# Location of Controls

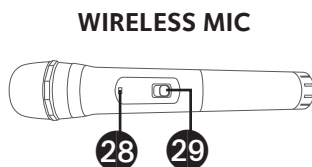
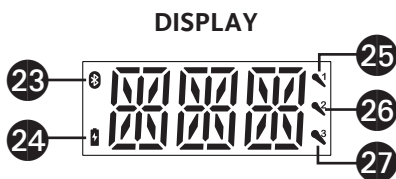
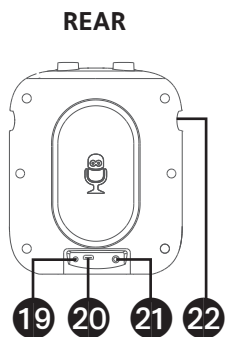
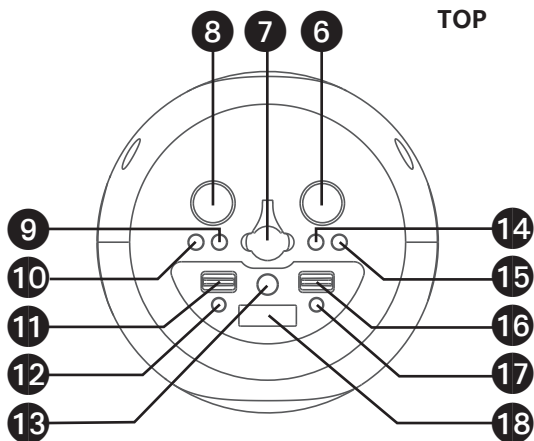
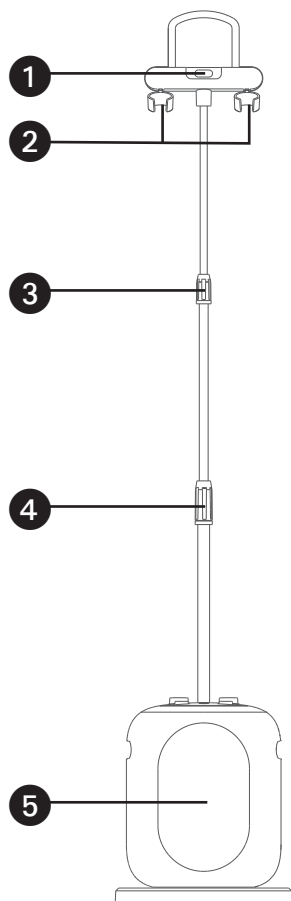

- |                                    |                                  |                                    |
|------------------------------------|----------------------------------|------------------------------------|
| 1. Cradle                          | 11. VOICE EFFECTS Control        | 21. Mic 3 Jack                     |
| 2. Mic Holders                     | 12.  Bluetooth/VOCALS OFF Button | 22. Handle                         |
| 3. Cradle pole adjustment cap      | 13.  (ON/STANDBY/ LIGHTS button) | 23. Bluetooth indicator            |
| 4. Height adjustment cap           | 14.  HOME Button                 | 24. Battery indicator              |
| 5. Speaker                         | 15.  BACK Button                 | 25. Mic 1 indicator (wireless)     |
| 6. NAVIGATION/ENTER Control        | 16. EFFECTS STRENGTH Control     | 26. Mic 2 indicator (wireless)     |
| 7. Rubber Cover                    | 17. PERFECT PITCH Button         | 27. Mic 3 indicator (wired)        |
| 8. MUSIC VOLUME/MIC VOLUME Control | 18. Display                      | 28. Wireless Mic battery indicator |
| 9. PLAYBACK Button                 | 19. DC IN Jack                   | 29. Wireless Mic ON/OFF button     |
| 10. RECORD Button                  | 20. HDMI Jack                    |                                    |

# Rechargeable Battery

This unit comes with a built-in rechargeable battery pack that will allow the unit to be used without being connected to AC power. The rechargeable battery pack must NOT to be replaced by the user.

To optimize the battery life, we recommend to charge the unit once a month. When the battery indicator on the display flashes slowly, recharge the unit by following the steps below:

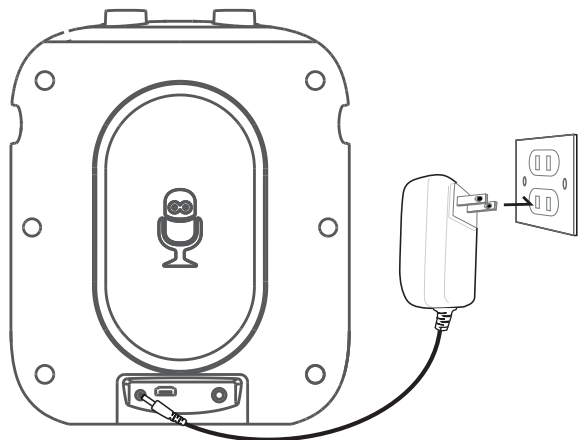

- 1 Insert the AC power cord into a conveniently located AC outlet having 120V, 60Hz.
- 2 Allow the unit to charge for approximately 8 hours for a full charge. When fully charged, the battery indicator will turn off.
- 3 Disconnect the AC cord and the fully charged unit can be used for approximately 4-10 hours depending on the function chosen.

**Attention:** The sound volume will adjust automatically when the battery is not full.

## Recycling and Disposal Information:

- Do not dispose of electronic devices or any of their components. (especially batteries and LCD displays) in your municipal trash collection.
- Consult your local waste management authority or a recycling organization like Earth911.com to find an electronics recycling facility in your area.



**CAUTION:** Rechargeable batteries must be recycled or disposed of properly.

---

# Energy Saving (Auto Power System-APS)

If there is no audio playback, the unit will automatically enter standby mode after 30 minutes.

The unit can be resumed to turn on by pressing the  button.

APS is for energy saving purposes.

# Connections

## Charging the unit

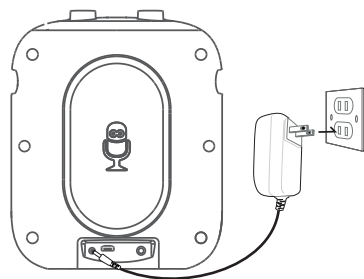

Insert the AC power cord into a conveniently located AC outlet having 120V AC, 60Hz.

### NOTES:

- Make all connections prior to plugging the AC adaptor into a power outlet.
- The AC adaptor has a polarized plug that fits into the AC outlet only one way. If the plug does not fit properly, turn it over and try again. Do not force and do not file or cut the wide blade.
- The provided AC adaptor can only support to charge the built-in rechargeable battery.

---

## Connecting the Unit to a TV

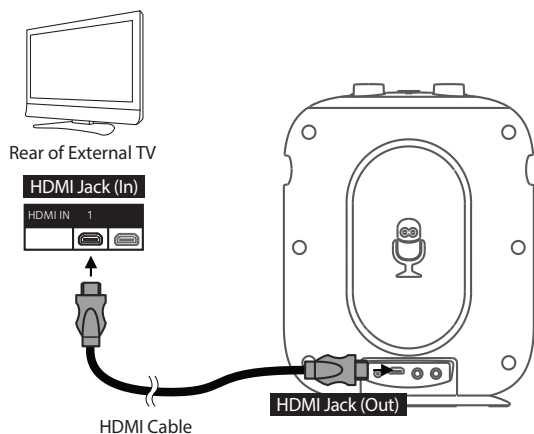

To output the casting video and casting audio to your TV, perform the following steps:

Plug the HDMI cable (not included) into the HDMI Jack on the back of the unit. Plug the other end of the HDMI cable into the HDMI input on your TV.

### Notes:

- This unit can be used with or without a TV, but it is highly recommended to use a TV in order to utilize all the features.
- Also refer to the TV's User Guide.
- Bluetooth audio and mic input cannot be output to your TV.



# Connections

## Connecting the Wireless Microphone(s)

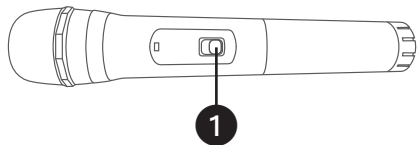

Slide the **MIC 1 or MIC 2 VOLUME** control, the Mic indicator 1 and 2 will appear in display and flash.

Slide the Wireless Mic's **ON/MUTE/OFF** **1** switch to the ON position. The Mic indicator 1 or 2 will light solid.

### NOTES:

- The working distance up to 30 feet/10 meters measured in open space.
- If there is no audio input for 15 minutes, the wireless mics connection will automatically turn off. Slide the **MIC 1 or MIC 2 VOLUME** control to reactivate the connection.

## Changing the Wireless Microphone's Battery

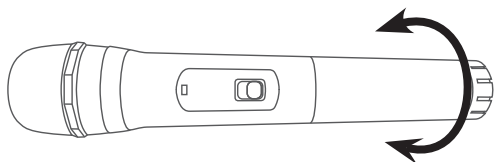

When the wireless mic battery indicator flashes, it shows it is out of power. Change the batteries as follows:

- 1 Unscrew the bottom of wireless microphone.
- 2 Replace the batteries with 2 x "AA" size/LR6 battery.
- 3 Replace the bottom of wireless microphone and screw it on.

### Battery Precautions

The precautions below should be followed when using batteries in this device:

1. Use only the size and type of batteries specified.
2. Be sure to follow the correct polarity when installing the batteries as indicated in the battery compartment. Reversed batteries may cause damage to the device.
3. Do not mix different types of batteries together (e.g. Alkaline and Carbon Zinc) or old batteries with fresh ones.
4. If the device is not to be used for a long period of time, remove the batteries to prevent damage or injury from possible battery leakage.
5. Do not try to recharge batteries not intended to be recharged, they can overheat and rupture. (Follow battery manufacturer's directions.)
6. Rechargeable batteries are to be removed from the product before being charged.
7. Rechargeable batteries are only to be charged under adult supervision.
8. Exhausted batteries are to be removed from the product.
9. Batteries shall not be exposed to excessive heat such as sunshine, fire or the like.

# Connections

## Connecting the optional wired Microphone

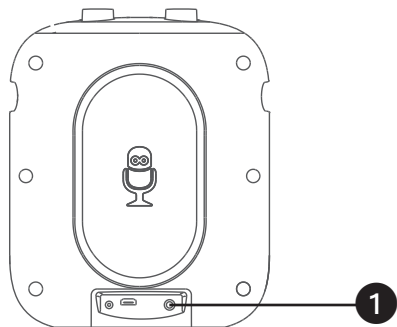

Connect the wired microphone (not included) into Mic jack ① (when desired).

**NOTE:** Maximum of two microphones (wired or wireless) connected to the unit at one time. After inserting the wired microphone (Mic 3), the wireless microphone 1 (Mic 1) will be automatically turned off.

---

## Lights Mode

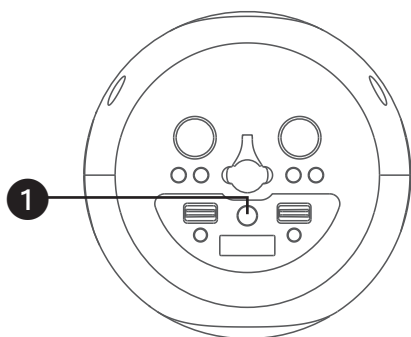

There are 5 built-in light mode. Repeatly press ☀️/⏻ button to switch between lighting effects.

---

## Cradle

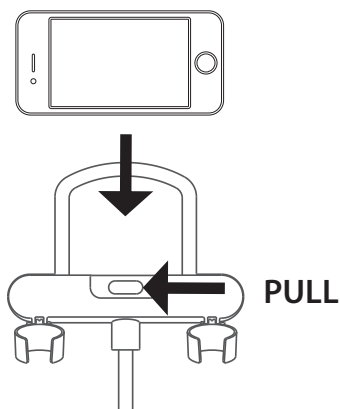

# Connections

## Connect to Wi-Fi

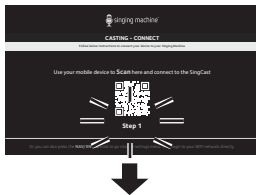
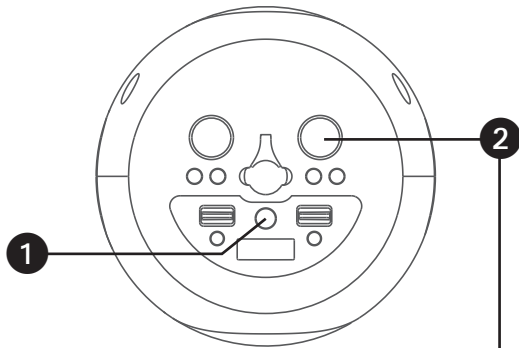

1

Connect the unit as described previously and ensure to connect it to a TV. Press and hold the **ON/STANDBY/LIGHTS** button to turn the unit on.

2

### USE YOUR MOBILE DEVICE TO CONNECT THIS UNIT

Use the **NAV/ENTER** control to select the **SINGCAST** icon on your TV screen. "CAS" will display on the screen. If this unit has not been connected to your Wi-Fi network, a step 1 QR code will pop up on screen. Use your mobile device to scan the QR code allowing it a moment to load. Once your mobile device connects to the unit successfully, the step 2 QR code will pop up on screen.

### NOTE:

- Rotate the **NAV/ENTER** control to navigate, press it to enter.

3

### CONNECT THIS UNIT TO YOUR Wi-Fi NETWORK

Use your mobile device to scan the step 2 QR code and allow it to load. The Wi-Fi list will pop up on your mobile device. Search for and select your home Wi-Fi and input your Wi-Fi password to complete the login process.

If the unit does NOT connect to your home Wi-Fi successfully, check your password and Wi-Fi frequency and repeat above steps.

### NOTES:

- This unit supports **2.4GHz Wi-Fi only**.
- Make sure the Wi-Fi network of the mobile device and unit are using the same network.
- WPA3 security settings can cause connection issues. If you have WPA3 security, we recommend lowering to WPA2 or lower. Or contact us for further help.

# Connections

## Connect to Wi-Fi (Continued)

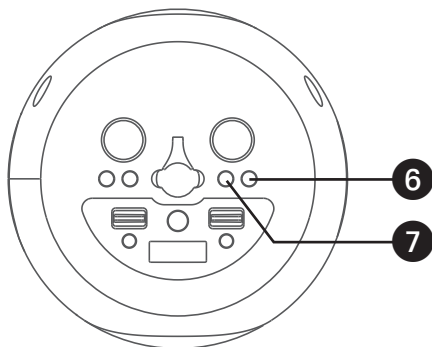
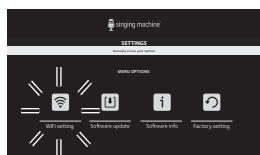
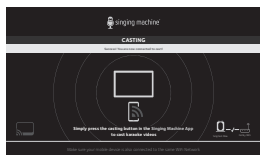

4 When the unit connects to your Wi-Fi successfully, "connected" will display on-screen. You can download the Singing Machine Karaoke App to listen to your favorite karaoke music and project the HD karaoke video on your TV.

5 The unit automatically searches and pairs to a previously paired Wi-Fi network. If you want to connect to another Wi-Fi network, you can go to the main menu and select **SETTINGS>WiFi setting>DISCONNECT** to disconnect from the Wi-Fi network in order to connect to another Wi-Fi network.

6 Press the **↶ BACK** button to go back to the previous screen.

7 Press the **🏠 HOME** button to go to the main menu.

# Connections

## Settings



1

Press the **HOME** button to go to the main menu. Using the **NAV/ENTER** control select the **SETTINGS** icon; "Set" will appear on-screen.

2

Select **Wi-Fi setting** to connect or disconnect from the Wi-Fi network and check the Wi-Fi signal level.

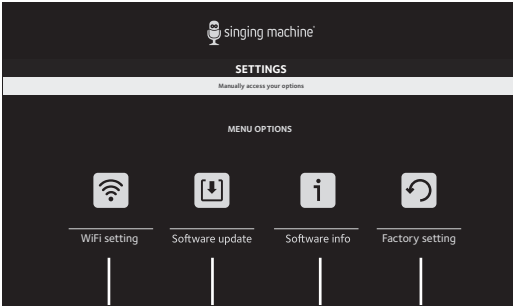

3

Select **Software update** to update the software of the unit.

4

Select **Software info** to check the latest software version of this unit.

5

Select **Factory setting** to delete all data stored in the unit.

# Operation

## Using SingCast Casting

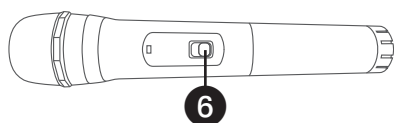
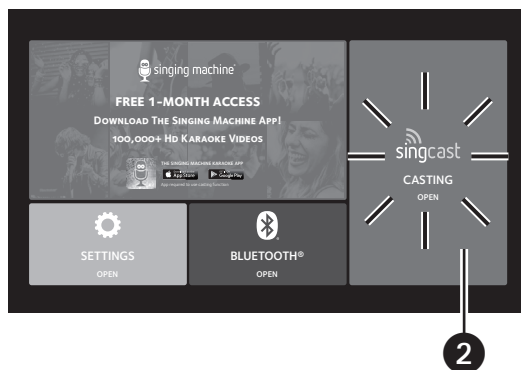
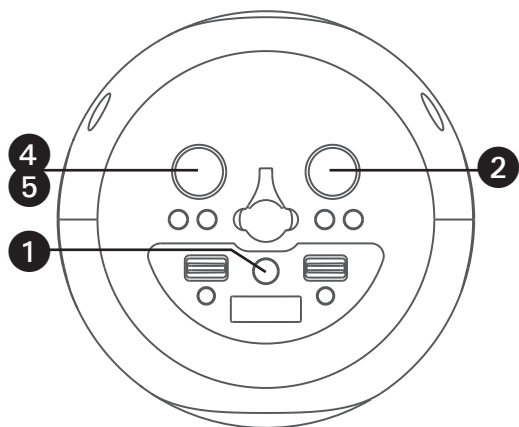

1 Connect the unit as described previously and ensure to connect it to a TV. Press and hold the **ON/STANDBY/LIGHTS** button to power on the unit.

2 Use the **NAV/ENTER** control to select the **SINGCAST** icon on your TV screen; "CAS" appears on the display.

3 Download the Singing Machine Karaoke App to choose from thousands of HD karaoke videos, project your favorite karaoke videos from your mobile device to your TV (make sure your mobile device and the unit are connected to the same Wi-Fi network).

4 Adjust the volume to a comfortable level using the **MUSIC VOL/MIC VOL** control.

5 Press and rotate the **MUSIC VOL/MIC VOL** control to adjust the volume of both microphones. After a few seconds of release, it will revert to the music volume control.

6 Slide the Wireless Mic's **ON / OFF** switch to the ON position.

**NOTE:** Slide to **MUTE** position is to temporary stop the microphone input.

# Operation

## Using SingCast Casting (Continued)

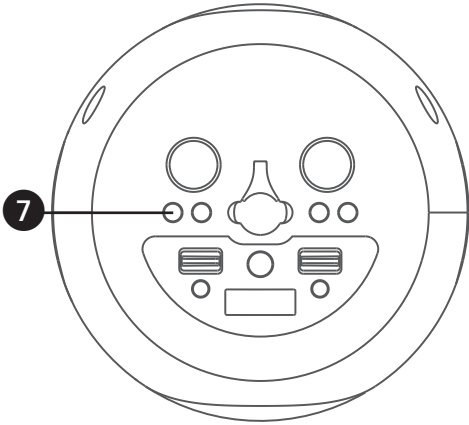

### 7 RECORD YOUR SINGING PERFORMANCE

During music playback, press the **RECORD** button to record your singing and the music, "REC" will appear solid on the display. Press the **RECORD** button again to stop recording, "REC" will turn off.

This unit is able to record for 5 minutes. It will also stop recording automatically after 5 minutes and "REC" will turn off.

**NOTE:** Please note that new recordings will cause previous recordings to be deleted.

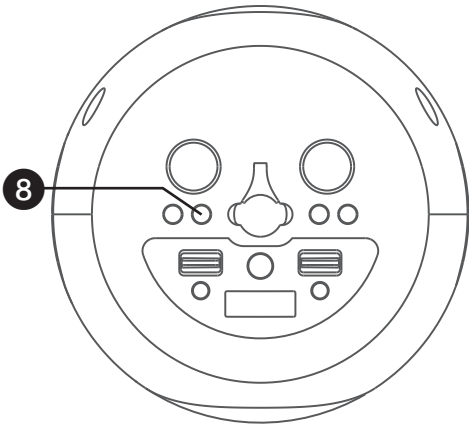

### 8 PLAYBACK YOUR SINGING PERFORMANCE

To playback your singing performance, you can press the **PLAYBACK** button. "PB" will appear on the display and light solid. Press again to stop. Press and hold the **PLAYBACK** button to delete the recorded track. A sound will be heard confirming the deletion of the track.

# Operation

## Using SingCast Casting (Continued)

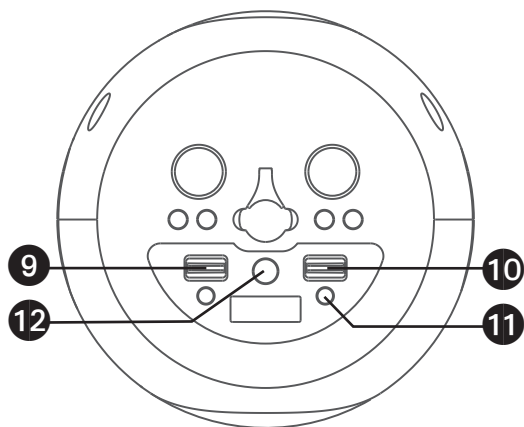

9 Toggle the **VOICE EFFECTS** control to select a voice effect.

10 Toggle the **EFFECTS STRENGTH** control to select the level of the selected vocal effects.

11 Press the **PERFECT PITCH** button to switch between the different levels of voice pitch. Display will show level.

**NOTE:** This function is only available for either Wireless Mic 1 or Mic 3.

12 Press and hold the **⏻/☀** button to turn off the unit.



# Operation

## Using a Bluetooth Device

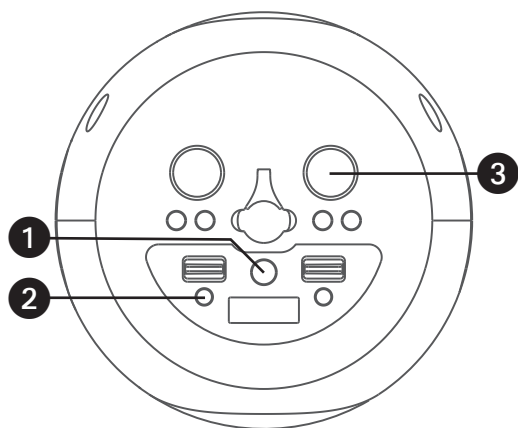

1 Connect the unit as described previously. Press and hold the **⏻ / ✨ (ON/STANDBY/LIGHTS)** button to turn the unit on.

2 **WAYS TO ENTER BLUETOOTH MODE**  
2 Press the **📶 / VOCALS OFF** button; “bt” will start to flash on the display.

3 Use the **NAV/ENTER** control to select **BLUETOOTH OPEN** in the main menu; the unit should be connected to a TV.

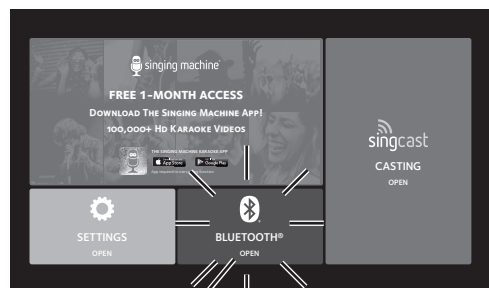

4 The unit automatically searches and pairs a previously paired Bluetooth device (if previously paired). If no previously paired devices are present and you cannot find this unit on your bluetooth compatible device’s search list.

Press and hold the **📶 / VOCALS OFF** button; the “PR” and bluetooth indicator will start flashing for 60 seconds.

**NOTE:** You can also press and hold the **📶 / VOCALS OFF** button to disconnect any paired device in order to pair another device.

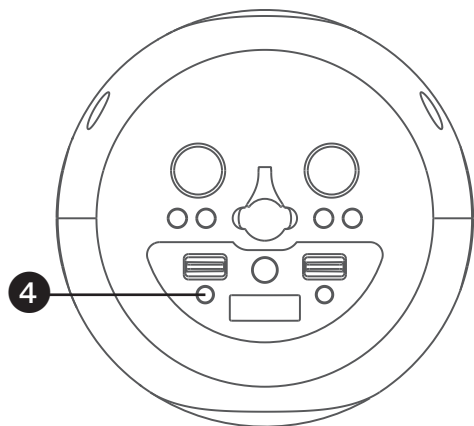

# Operation

## Using a Bluetooth Device (Continued)

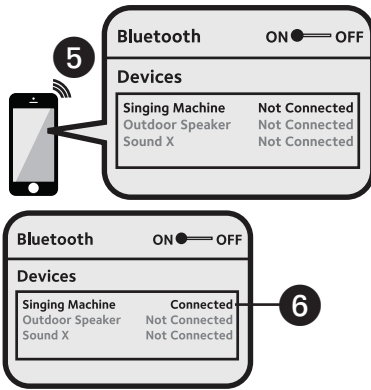

5 Turn on your device’s Bluetooth option in settings to search for a discoverable device with a Bluetooth signal. Select “**SINGING MACHINE**” from the device results on the Bluetooth menu.

**NOTE:** Also refer to the user manual of your Bluetooth device for detailed instructions.

6 “bt” and bluetooth indicator will light solid.

### NOTES:

- If your Bluetooth prompts you for a passcode during the pairing process, please enter “0000” to connect.
- On some Bluetooth devices, once pairing is completed, select your Bluetooth device as “Use as Audio Device” or similar.
- If connection is lost after successful pairing, check to make sure the distance between speaker and Bluetooth-enabled device does not exceed 30 feet/10 meters.

7 Adjust the volume to a comfortable level using the **MUSIC VOL/MIC VOL** control on this unit as well as the volume on your Bluetooth device.

**NOTE:** Bluetooth music and your singing performance are only played on the unit.

8 Press and rotate the **MUSIC VOL/MIC VOL** control to adjust the volume of both microphones. After a few seconds of release, it will revert to the music volume control.

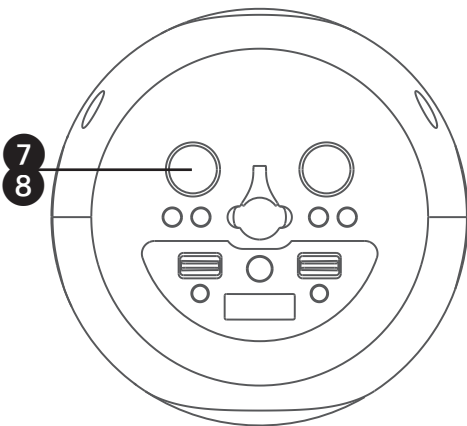

# Operation

## Using a Bluetooth Device (Continued)

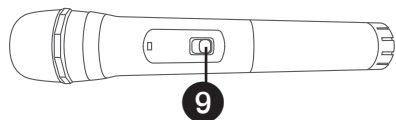

9 Slide the Wireless Mic's **ON / OFF** switch to the ON position.

**NOTE:** Slide to **MUTE** position is to temporary stop the microphone input.

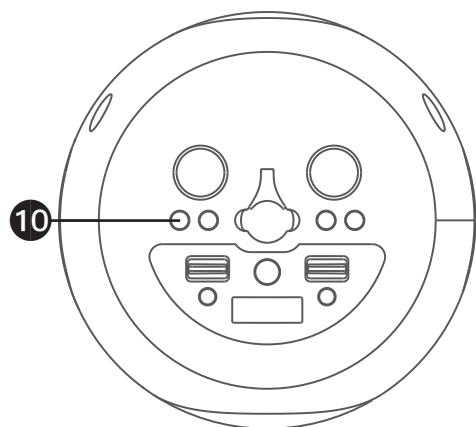

## 10 RECORD YOUR SINGING PERFORMANCE

During music playback, press the **RECORD** button to record your singing and the music, "REC" will appear in display and light solid. Press the **RECORD** button again to stop recording, the "REC" will turn off.

This unit is able to record for 5 minutes. It will also stop recording automatically after 5 minutes and the "REC" will turn off.

**NOTE:** Please note that each time when the new recording is being recorded, the existing recording will be deleted.

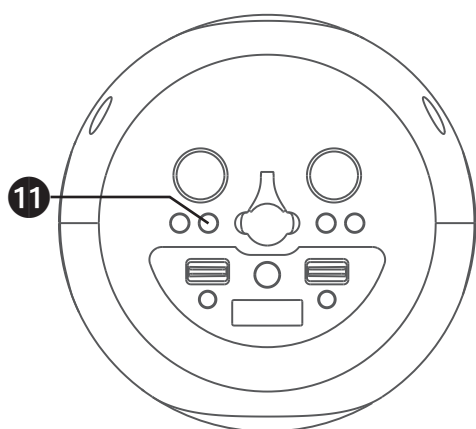

## 11 PLAYBACK YOUR SINGING PERFORMANCE

To playback your singing performance, you can press the **PLAYBACK** button. "PB" will appear solid on the display. Press again to stop. Press and hold the **PLAYBACK** button to delete the recorded track.

# Operation

## Using a Bluetooth Device (Continued)

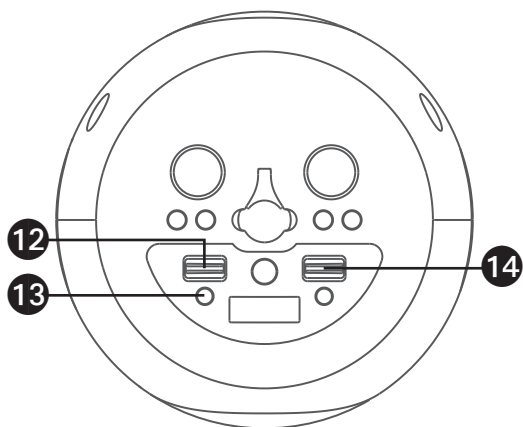

**12** Toggle the **VOICE EFFECTS** control to select a voice effect.

**13** To sing without the lead singer on the recording, press the **⊗/ VOCALS OFF** button. To resume the lead singer, press again.

**NOTE:** Lead vocal removal might work better on some songs than others.

**14** Toggle the **EFFECTS STRENGTH** control to select the level of the selected vocal effects.

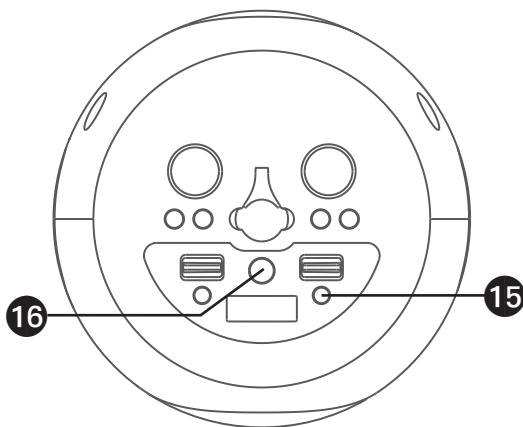

**15** Press the **PERFECT PITCH** button to switch between the different levels of voice pitch. Display will show level.

**NOTE:** This function is only available for either Wireless Mic 1 or Mic 3.

**16** Press and hold the **⏻/☀** button to turn off the unit.

# Troubleshooting Guide

Should this unit exhibit a problem, check the following before seeking service:

## No Power

- Power is not on; press and hold the  button to turn power on.
- The unit has no battery left. Connect to AC power to recharge the battery.
- Confirm that the AC adapter is connected securely to the rear of the unit.
- Connect the unit to a different outlet.
- The normal function of the product may be disturbed by strong Electro-Magnetic Interference. If so, simply restart the product to resume normal operation by following the instruction manual. In case the function could not resume, please use the product in another location.

## No Sound – General

- **MUSIC VOL/MIC VOL** is set to minimum; raise volume.

## No Sound – If connected to a TV

- Correct mode (SingCast) was not selected on the unit.
- Bluetooth music audio and singing performance cannot output to the TV.
- Volume on the TV is muted or too low.
- Correct source (usually HDMI) was not selected on the TV's menu.

## No sound from the microphone

- The wireless microphone has no battery left. Change the batteries.
- Make sure the mic's **ON/OFF** switch is set to the ON position.
- Make sure the **MUSIC VOL/MIC VOL** control is not set too low.
- Microphone input cannot output to the TV.

## The Bluetooth device cannot be paired or connected with the unit

- Ensure any other Bluetooth devices are turned off to avoid accidental pairing.
- You have not activated the Bluetooth function of your device; see page E16 or refer to the Bluetooth device user's manual.
- The system is not in pairing mode; press and hold the /VOCALS OFF button to restart pairing.

## The Music is not available on the unit after successfully connecting to Bluetooth

- Ensure your Bluetooth device can support the A2DP Bluetooth profile.
- The volume on the external Bluetooth device is set too low or muted; raise as desired.

## Failed to connect to the Wi-Fi network

- The unit is not within the Wi-Fi signal range.
- Check that your Wi-Fi frequency is 2.4GHz.
- Ensure you have entered the correct password.
- Check that the mobile device and unit are using the same Wi-Fi network.
- WPA3 security settings can cause connection issues. If you have WPA3 security, we recommend lowering to WPA2 or lower. Or contact us for further help.

# Need Help Casting? Start here!

## Scanning QR code fail

- We recommend for you to scan the QR Code once more. If you cannot scan it successfully, you may need to try a specific QR code scanning APP to help.
- Alternatively, you can go into "SETTINGS menu/Wi-Fi setting" to connect the SingCast unit to your Wi-Fi network directly.

## No Internet connection

- Ensure the unit is in SingCast mode.
- Ensure the input Wi-Fi password is correct.
- Ensure the SingCast unit is not too far from your router (recommended maximum 10 meters). If the Wi-Fi signal level is weak, we recommend that you relocate the SingCast unit closer to the router.
- Check that your Wi-Fi frequency is 2.4GHz.
- This unit is only compatible with Wi-Fi security WPA3 or lower. Please check out below compatible Wi-Fi security list.  
WPA, WPA-PSK, WPA2, WPA2-PSK, WPA3, WEP 64bit & 128bit, IEEE 802.11x and IEEE 802.11i.
- If your Wi-Fi security is set to above WPA3 on your router, you will need to set it to WPA3 or lower.
- Depending on the brand of your router, if you still cannot connect to the router with WPA3 or lower security standard, you are recommended to factory reset your router. \*Make sure you have written down your existing customized SSID name and password. This will help in reconnecting your previously connected devices and revert to your previous Wi-Fi security settings.
- If the Singing Machines unit's Wi-Fi is connected to the router successfully. But you still cannot connect to the internet. You might need to check for any internet connection problems on your router. Or check out the router's settings to verify if that the unit is not restricted from going online. You are highly recommended to refer to your router's instruction manual.
- To ensure the unit's Wi-Fi function works fine, you can connect your unit's Wi-Fi to your mobile device's hotspot with data service to verify.

## Cannot find the SingCast unit on your Karaoke app casting list / No Casting video to TV

- Ensure both the SingCast unit and your mobile device are connected to the same Wi-Fi network.
- If SingCast does not appear as a casting option, check advanced security settings to enable DLNA.
- If you are connecting a router with Mesh function, you need to make sure "Access Intranet" function is enabled.

# Specifications

## AUDIO

Output Power .....70 Watts (RMS)

## BLUETOOTH

Bluetooth Version ..... V5.0

Working Distance..... Up to 30 feet/10 meters measured in open space

## Wi-Fi

Wi-Fi frequency ..... 2.4GHz

## CONNECTING JACKS

Microphone ..... 6.3mm

## GENERAL

Power ..... 100-240V, 50/60Hz

Output ..... DC9V 1A Positive Center

### Dimensions:

Main Unit only ..... 10.3 x 10.3 x 12.6 inches (26.2 x 26.2 x 32cm)

Base + Mic stand + Mic holders Adjustable height max. 57.3 H inches/ 145.6cm (optional)

Base + Main unit + Mic stand + Mic holders ..... Adjustable height max. 68.7 H inches/  
174.6cm (optional)

Base ..... 11.9 x 11.9 x 1.5 inches (30.1 x 30.1 x 3.9cm)

Weight - Main Unit only ..... 9.7 Lbs (4.4 kgs)

Base + Mic Stand + Mic holders ..... 7.7 Lbs (3.5 kgs)

Wireless Microphone ..... VHF band (210.5MHz/215.5 MHz Freq) Dynamic Microphone

Specifications are subject to change without notice.



The terms HDMI and HDMI High-Definition Multimedia Interface, and the HDMI Logo are trademarks or registered trademarks of HDMI Licensing Administrator, Inc. in the United States and other countries.



The Bluetooth® word mark and logos are registered trademarks owned by Bluetooth SIG, Inc. and any use of such marks and logos by The Singing Machine Company, Inc. is under license. Other trademarks and trade names are those of their respective owners.