

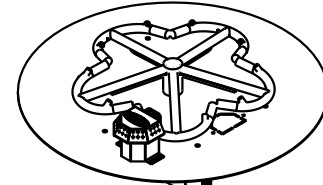

FIRE INSPIRED®

**CSA CERTIFIED-OUTDOOR USE ONLY
FOR COMMERCIAL AND RESIDENTIAL USE**

HEARTH PRODUCTS CONTROLS
2225 LYONS RD.
MIAMISBURG, OH 45342
TOLL FREE: 877.585.9800
PHONE: 937.436.9800
www.hpcfire.com

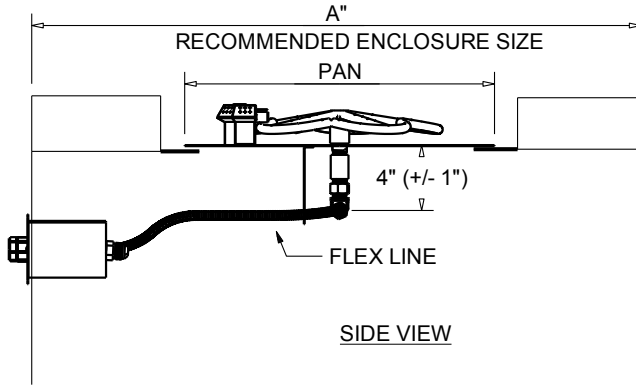

EXAMPLE:
TOR-PENTA18FPPK-FLEX

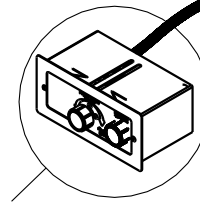

VALVE BOX DETAIL

ISOMETRIC VIEW

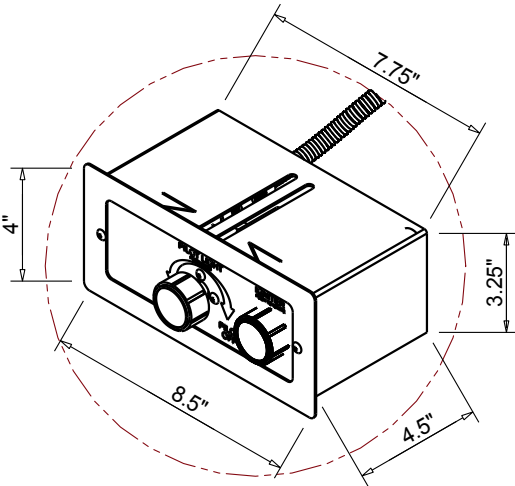

VALVE BOX DETAIL

SPARK IGNITION BY AA BATTERY
MATERIAL: 304 STAINLESS STEEL

PART NUMBERS	DIMENSION CHART				
	PAN	STANDARD BTU		A"	STND FLEX LINE LENGTH
PENTA BURNER		PENTA	TORPEDO		
TOR- PENTA18-FPPK-FLEX	17.75"	65K	65K	45"	36"
TOR- PENTA24-FPPK-FLEX	23.75"	90K	125K	54"	36"
TOR- PENTA30-FPPK-FLEX	29.75"	140K	150K	54"	36"
TOR- PENTA36-FPPK-FLEX	35.75"	140K	175K	54"	36"

PART NUMBERS	DIMENSION CHART			
	PAN	STANDARD BTU	A"	STND FLEX LINE LENGTH
ROUND BURNER FPPK14-FLEX	13.75"	90K	45"	36"

*FOR TORPEDO BURNERS ADD TOR-

Notes:

1. PROPER VENTING
 - ENCLOSURES: Recommend 4 each 18 sq.in. vents on opposing sides (Minimum 2 each 18 sq.in. vents).
 2. GAS SUPPLY - FOR USE WITH FIXED PIPING SYSTEMS OR FOR USE WITH SMALL TANKS UP TO 90K.
 - Natural Gas: Operating Supply Pressure: Minimum: 6.0" W.C.; Maximum: 7.0" W.C.
 - LP Gas: Operating Supply Pressure: Minimum: 10.0" W.C.; Maximum: 11.0" W.C.
- IMPORTANT: Ensure any flex line that may be used from the permanent main fuel supply to the product is rated to the stated max btu of the product and certified to ANSI Z21.75*CSA 6.27.
5. MODIFICATION OF PRODUCT WILL VOID ANY CERTIFICATION AND WARRANTY.
 6. FOLLOW ALL MANUFACTURER INSTALLATION INSTRUCTIONS AND LOCAL CODES.
 7. ALL DIMENSIONS ARE CONSIDERED TRUE AND REFLECT MANUFACTURER'S SPECIFICATIONS AS OF THE REVISION DATE.
 8. DO NOT SCALE DRAWING.
 9. THESE DRAWINGS ARE FOR SIZING AND PLANNING PURPOSES. ALL INFORMATION CONTAINED HEREIN WAS CURRENT AT THE TIME OF DEVELOPMENT. THE MANUFACTURER'S RESPONSIBLE FOR THE ACCURACY OF THE DRAWING.
 10. CONTRACTOR'S NOTE: FOR PRODUCT AND COMPANY INFORMATION VISIT www.CADdetails.com/info REFERENCE NUMBER 771-001.

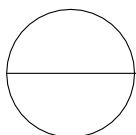

PUSH BUTTON/FLAME SENSING FIRE PIT INSERT - WITH FLEX LINE
FLAT ROUND PAN - FPPK