

4

3

2

1

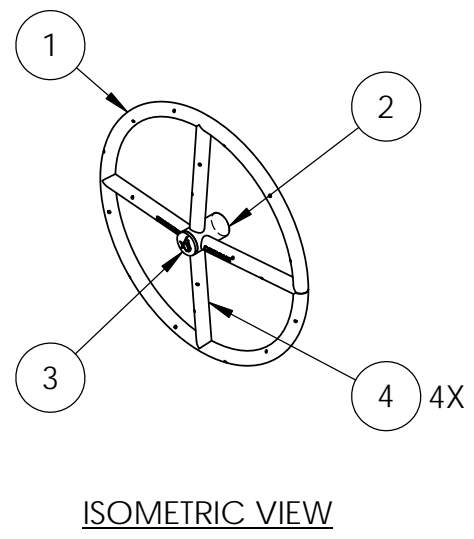
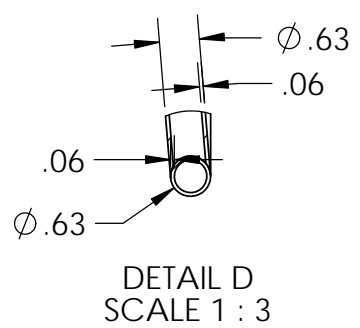
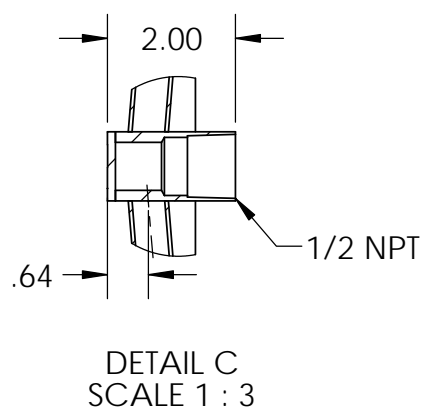
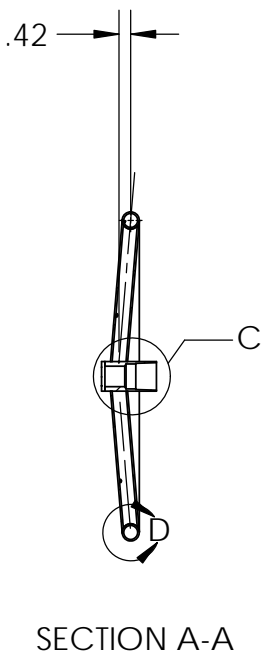
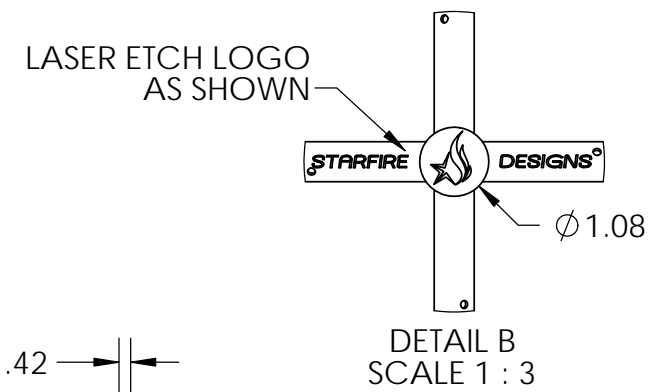
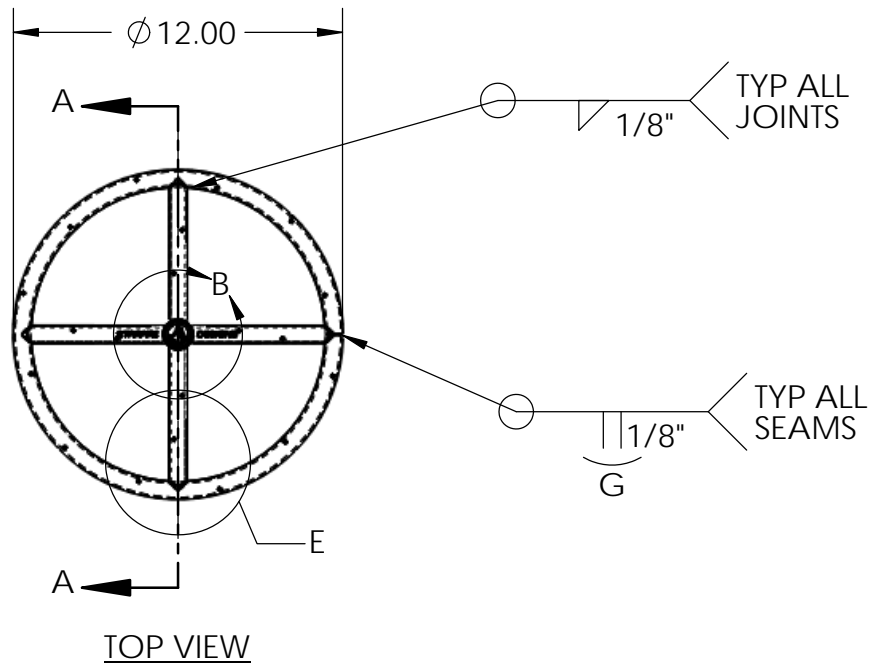

- NOTES:**
- ALL DIMENSIONS ARE IN INCHES UNLESS OTHERWISE SPECIFIED.
  - MATERIAL: 304SS
  - UNIT WEIGHT: \_\_\_\_\_ LBS
  - FOR OUTDOOR USE ONLY

ITEM NO.	QTY.	DESCRIPTION	LENGTH
4	4	AI RND TUBE 0.625 OD x 0.058 Wall	5.27
3	1	END CAP, 1/8" THK	
2	1	AI RND TUBE 1 OD x 0.095 Wall	1.88
1	1	AI RND TUBE 0.625 OD x 0.058 Wall	35.72

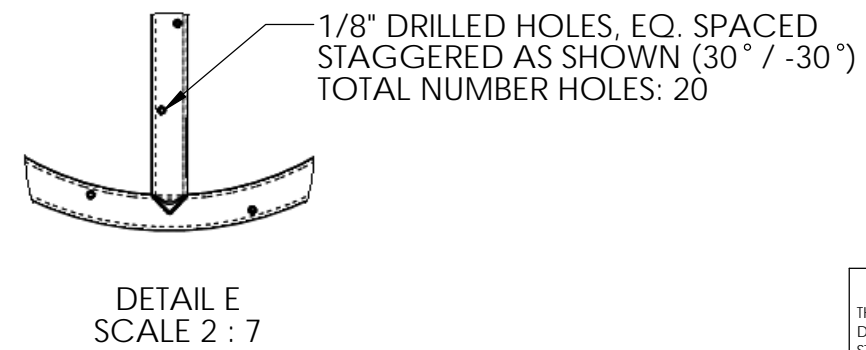

**PROPRIETARY AND CONFIDENTIAL**  
THE INFORMATION CONTAINED IN THIS DRAWING IS THE SOLE PROPERTY OF STARFIRE DIRECT. ANY REPRODUCTION IN PART OR AS A WHOLE WITHOUT THE WRITTEN PERMISSION OF STARFIRE DIRECT IS PROHIBITED.

UNLESS OTHERWISE SPECIFIED:		NAME	DATE	TITLE:
DIMENSIONS ARE IN INCHES TOLERANCES: FRACTIONAL ± 1/8" ANGULAR: MACH ± BEND ± TWO PLACE DECIMAL ± THREE PLACE DECIMAL ±		DRAWN		<b>ROUND BURNER</b> Ø 12" OD
INTERPRET GEOMETRIC TOLERANCING PER:		CHECKED		
MATERIAL 304 SS		ENG APPR.		
FINISH		MFG APPR.		
NEXT ASSY	USED ON	Q.A.		SIZE <b>B</b>
APPLICATION		DO NOT SCALE DRAWING		DWG. NO. SD-FR-12
				REV <b>A</b>
				SCALE: 1:7
				WEIGHT:
				SHEET 1 OF 1



4

3

2

1

B

B

A

A

4

3

2

1

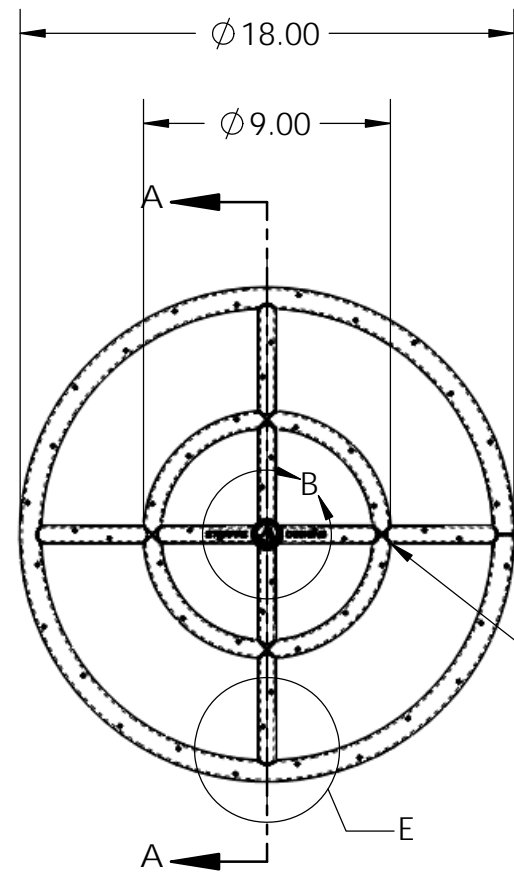

TOP VIEW

TYP ALL SEAMS  
1/8"

TYP ALL JOINTS  
1/8"

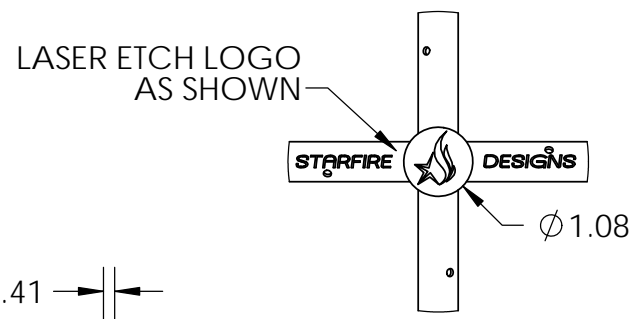

DETAIL B  
SCALE 1 : 3

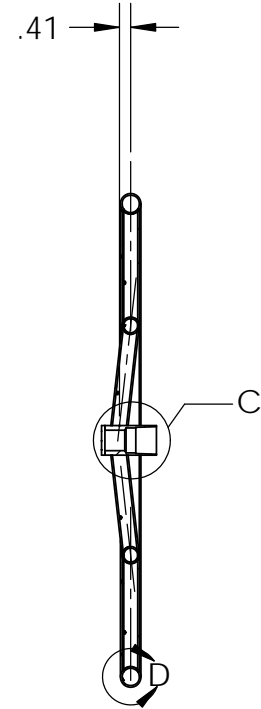

SECTION A-A

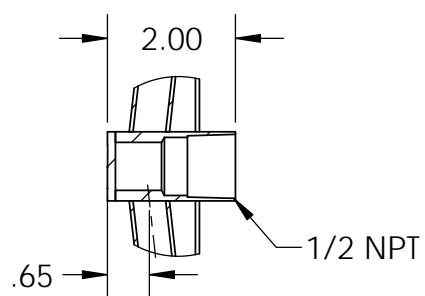

DETAIL C  
SCALE 1 : 3

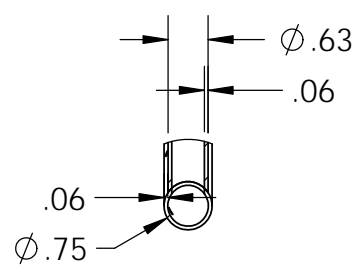

DETAIL D  
SCALE 1 : 3

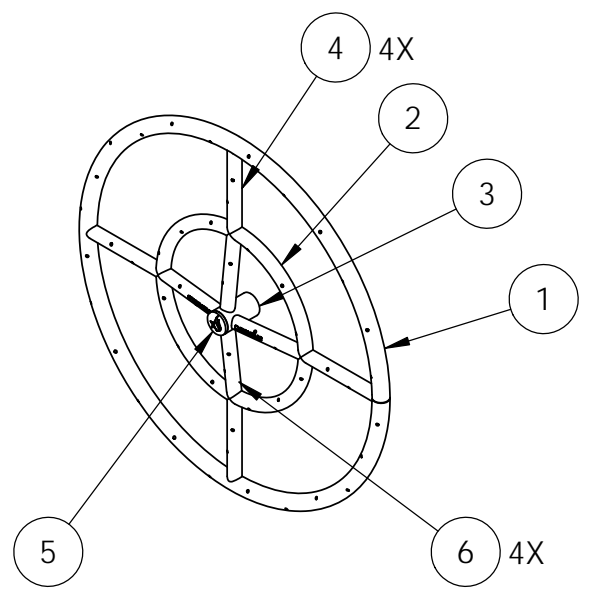

ISOMETRIC VIEW

**NOTES:**

- ALL DIMENSIONS ARE IN INCHES UNLESS OTHERWISE SPECIFIED.
- MATERIAL: 304SS
- UNIT WEIGHT: \_\_\_\_\_ LBS
- FOR OUTDOOR USE ONLY

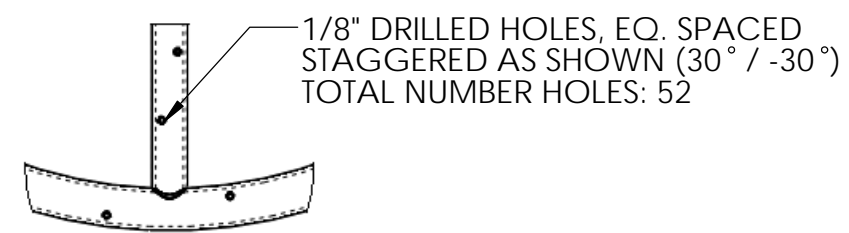

DETAIL E  
SCALE 2 : 7

1/8" DRILLED HOLES, EQ. SPACED  
STAGGERED AS SHOWN (30° / -30°)  
TOTAL NUMBER HOLES: 52

ITEM NO.	QTY.	DESCRIPTION	LENGTH
6	4	AI RND TUBE 0.625 OD x 0.058 Wall	3.77
5	1	END CAP, 1/8" THK	
4	4	AI RND TUBE 0.625 OD x 0.058 Wall	4.23
3	1	AI RND TUBE 1 OD x 0.095 Wall	1.88
2	1	AI RND TUBE 0.625 OD x 0.058 Wall	26.31
1	1	AI RND TUBE 0.75 OD x 0.058 Wall	54.19

**PROPRIETARY AND CONFIDENTIAL**  
THE INFORMATION CONTAINED IN THIS DRAWING IS THE SOLE PROPERTY OF STARFIRE DIRECT. ANY REPRODUCTION IN PART OR AS A WHOLE WITHOUT THE WRITTEN PERMISSION OF STARFIRE DIRECT IS PROHIBITED.

UNLESS OTHERWISE SPECIFIED:		NAME	DATE	TITLE:	
DIMENSIONS ARE IN INCHES TOLERANCES: FRACTIONAL ± 1/8" ANGULAR: MACH ± BEND ± TWO PLACE DECIMAL ± THREE PLACE DECIMAL ±		DRAWN		<b>ROUND BURNER</b> Ø 18" OD	
INTERPRET GEOMETRIC TOLERANCING PER:		CHECKED			
MATERIAL		ENG APPR.			
FINISH		MFG APPR.			
NEXT ASSY	USED ON	Q.A.		SIZE <b>B</b> DWG. NO. SD-FR-18 REV <b>A</b>	
APPLICATION		DO NOT SCALE DRAWING		SCALE: 1:7 WEIGHT: SHEET 1 OF 1	

4

3

2

1

4

3

2

1

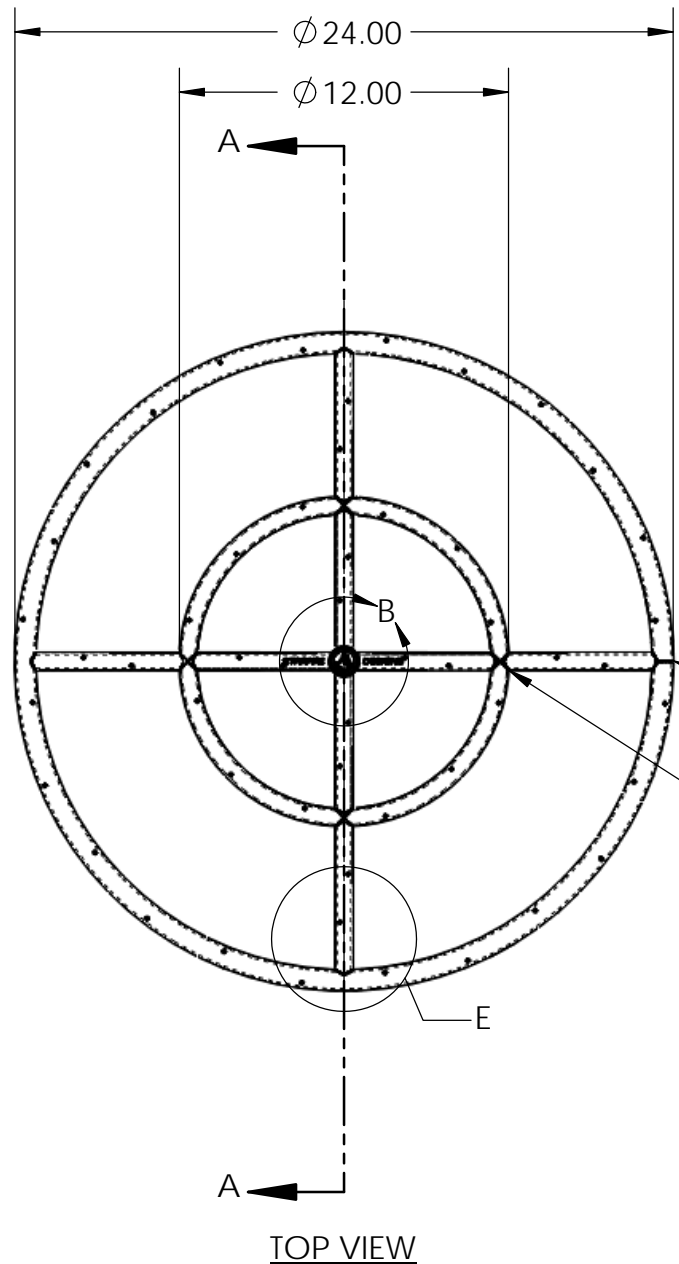

TOP VIEW

TYP ALL SEAMS  
1/8"

TYP ALL JOINTS  
1/8"

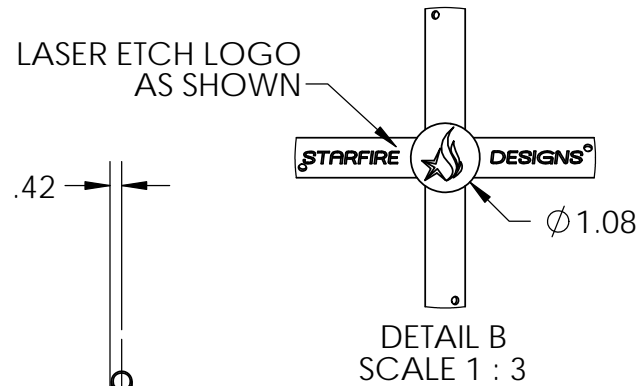

DETAIL B SCALE 1 : 3

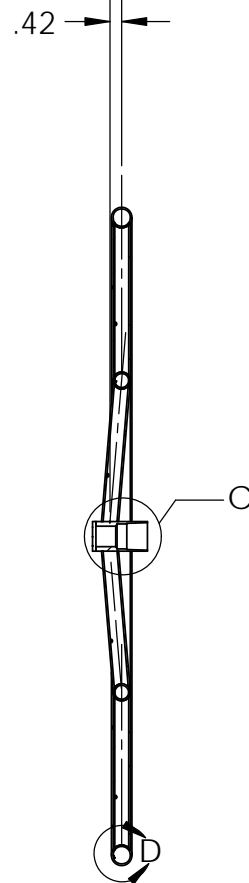

SECTION A-A

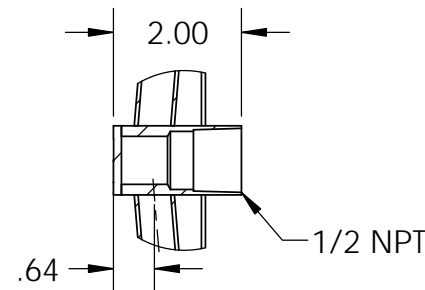

DETAIL C SCALE 1 : 3

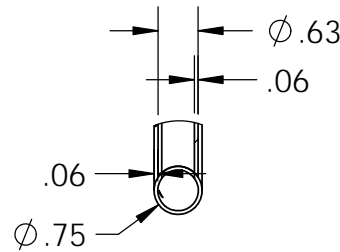

DETAIL D SCALE 1 : 3

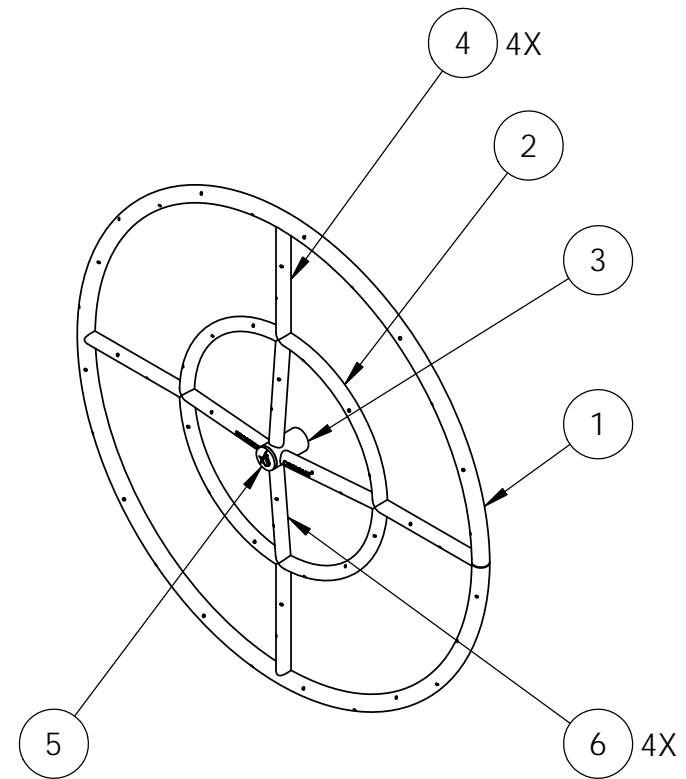

ISOMETRIC VIEW

NOTES:

- 1. ALL DIMENSIONS ARE IN INCHES UNLESS OTHERWISE SPECIFIED.
- 2. MATERIAL: 304SS
- 3. UNIT WEIGHT: \_\_\_\_\_ LBS
- 4. FOR OUTDOOR USE ONLY

ITEM NO.	QTY.	DESCRIPTION	LENGTH
6	4	AI RND TUBE 0.625 OD x 0.058 Wall	5.27
5	1	END CAP, 1/8" THK	
4	4	AI RND TUBE 0.625 OD x 0.058 Wall	5.73
3	1	AI RND TUBE 1 OD x 0.095 Wall	1.88
2	1	AI RND TUBE 0.625 OD x 0.058 Wall	35.74
1	1	AI RND TUBE 0.75 OD x 0.058 Wall	73.04

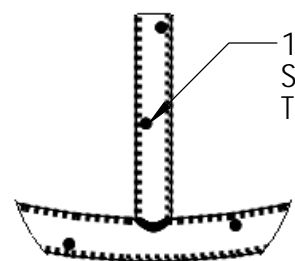

DETAIL E SCALE 2 : 7

1/8" DRILLED HOLES, EQ. SPACED  
STAGGERED AS SHOWN (30° / -30°)  
TOTAL NUMBER HOLES: 52

**PROPRIETARY AND CONFIDENTIAL**  
THE INFORMATION CONTAINED IN THIS DRAWING IS THE SOLE PROPERTY OF STARFIRE DIRECT. ANY REPRODUCTION IN PART OR AS A WHOLE WITHOUT THE WRITTEN PERMISSION OF STARFIRE DIRECT IS PROHIBITED.

UNLESS OTHERWISE SPECIFIED:		NAME	DATE	TITLE:	
DIMENSIONS ARE IN INCHES TOLERANCES: FRACTIONAL ± 1/8" ANGULAR: MACH ± BEND ± TWO PLACE DECIMAL ± THREE PLACE DECIMAL ±		DRAWN		<b>ROUND BURNER</b> $\phi$ 24" OD	
INTERPRET GEOMETRIC TOLERANCING PER:		CHECKED			
MATERIAL 304 SS		ENG APPR.			
FINISH		MFG APPR.			
NEXT ASSY	USED ON	Q.A.		SIZE <b>B</b>	DWG. NO. SD-FR-24
APPLICATION				SCALE: 1:7	WEIGHT:
				REV <b>A</b>	
				SHEET 1 OF 1	

4

3

2

1

4

3

2

1

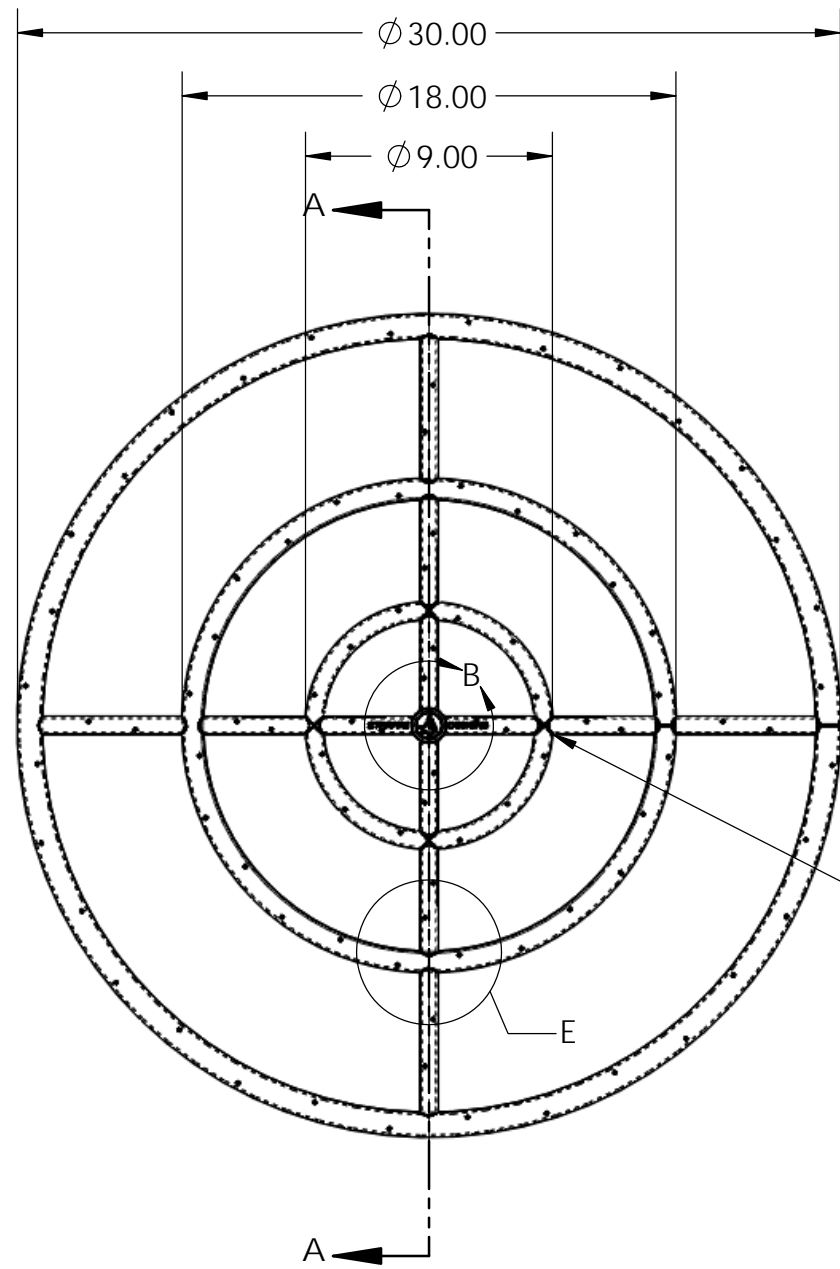

TOP VIEW

LASER ETCH LOGO AS SHOWN

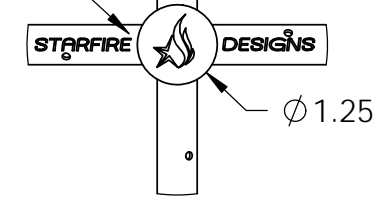

DETAIL B SCALE 1 : 3

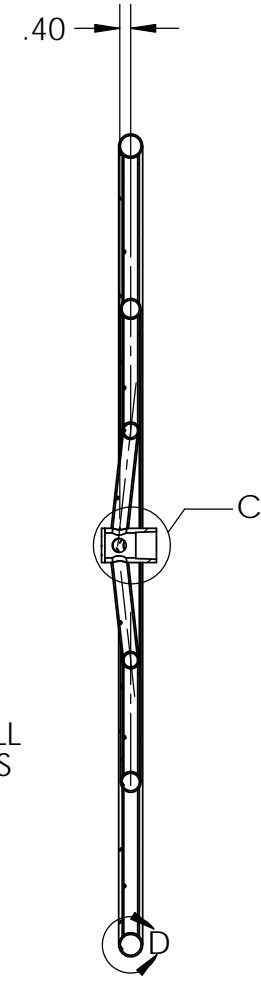

SECTION A-A

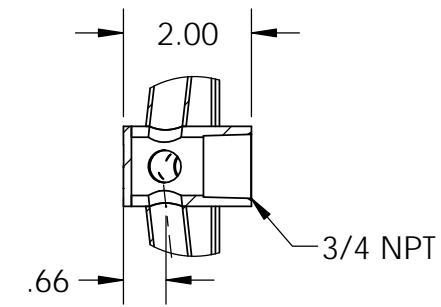

DETAIL C SCALE 1 : 3

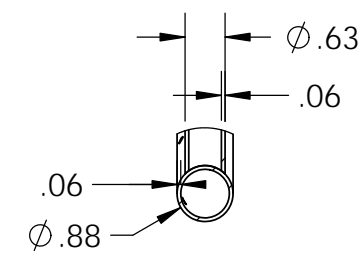

DETAIL D SCALE 1 : 3

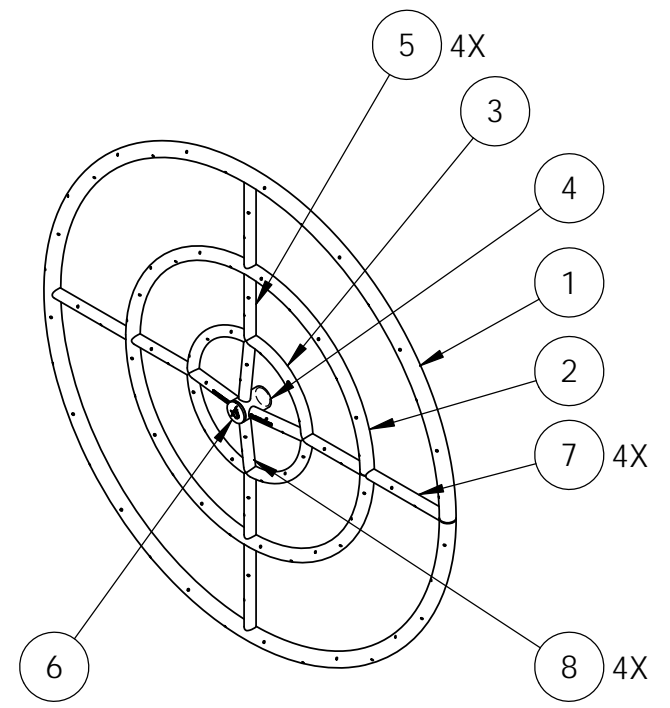

ISOMETRIC VIEW

TYP ALL SEAMS  
1/8"

TYP ALL JOINTS  
1/8"

NOTES:

- ALL DIMENSIONS ARE IN INCHES UNLESS OTHERWISE SPECIFIED.
- MATERIAL: 304SS
- UNIT WEIGHT: \_\_\_\_\_ LBS
- FOR OUTDOOR USE ONLY

ITEM NO.	QTY.	DESCRIPTION	LENGTH
8	4	AI RND TUBE 0.625 OD x 0.058 Wall	3.67
7	4	AI RND TUBE 0.625 OD x 0.058 Wall	5.42
6	1	END CAP, 1/8" THK	
5	4	AI RND TUBE 0.625 OD x 0.058 Wall	4.23
4	1	AI RND TUBE 1.25 OD x 0.125 Wall	1.88
3	1	AI RND TUBE 0.625 OD x 0.058 Wall	26.31
2	1	AI RND TUBE 0.75 OD x 0.058 Wall	54.16
1	1	AI RND TUBE 0.875 OD x 0.058 Wall	91.44

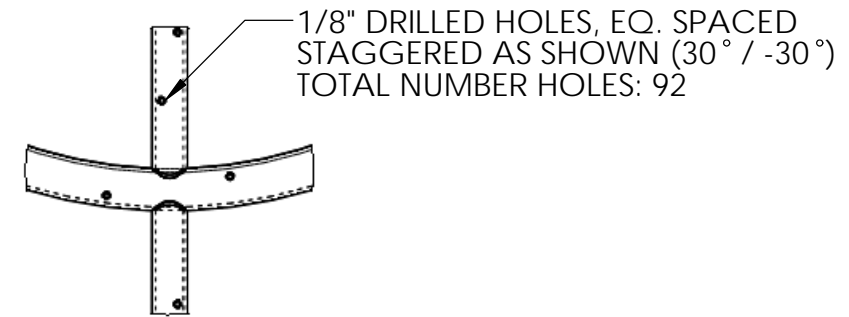

DETAIL E SCALE 2 : 7

1/8" DRILLED HOLES, EQ. SPACED  
STAGGERED AS SHOWN (30° / -30°)  
TOTAL NUMBER HOLES: 92

**PROPRIETARY AND CONFIDENTIAL**  
THE INFORMATION CONTAINED IN THIS DRAWING IS THE SOLE PROPERTY OF STARFIRE DIRECT. ANY REPRODUCTION IN PART OR AS A WHOLE WITHOUT THE WRITTEN PERMISSION OF STARFIRE DIRECT IS PROHIBITED.

UNLESS OTHERWISE SPECIFIED:		NAME	DATE	TITLE:	
DIMENSIONS ARE IN INCHES TOLERANCES: FRACTIONAL: ± 1/8" ANGULAR: MACH ± BEND ± TWO PLACE DECIMAL ± THREE PLACE DECIMAL ±		DRAWN		<b>ROUND BURNER</b> $\phi$ 30" OD	
INTERPRET GEOMETRIC TOLERANCING PER:		CHECKED			
MATERIAL 304 SS		ENG APPR.			
FINISH		MFG APPR.			
NEXT ASSY	USED ON	Q.A.		SIZE <b>B</b>	DWG. NO. SD-FR-30
APPLICATION		DO NOT SCALE DRAWING		SCALE: 1:7	WEIGHT:
				REV <b>A</b>	SHEET 1 OF 1

4

3

2

1

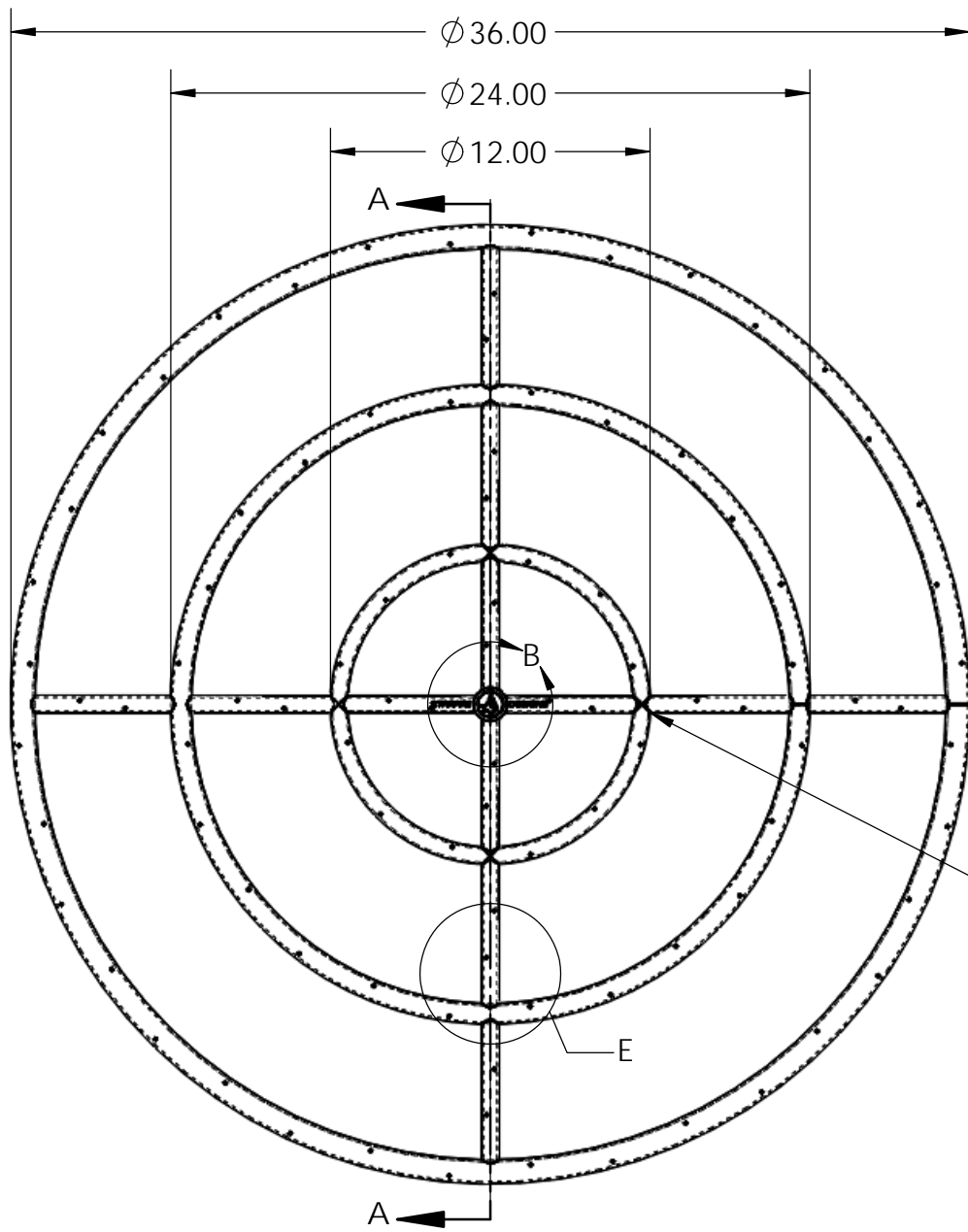

TOP VIEW

LASER ETCH LOGO AS SHOWN

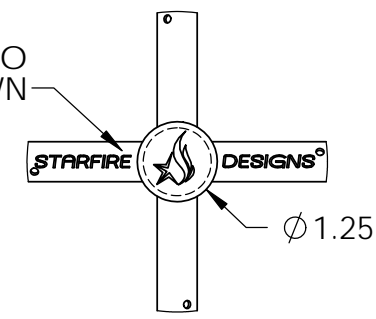

DETAIL B SCALE 1 : 3

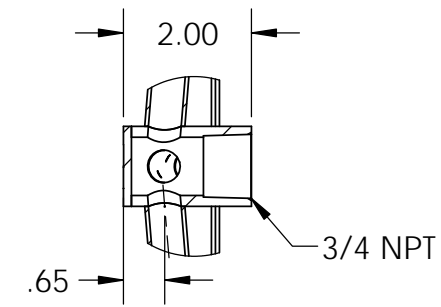

DETAIL C SCALE 1 : 3

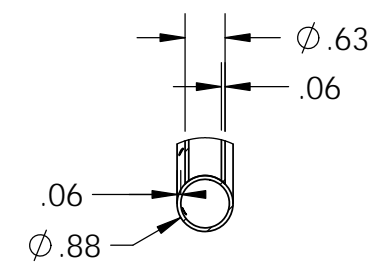

DETAIL D SCALE 1 : 3

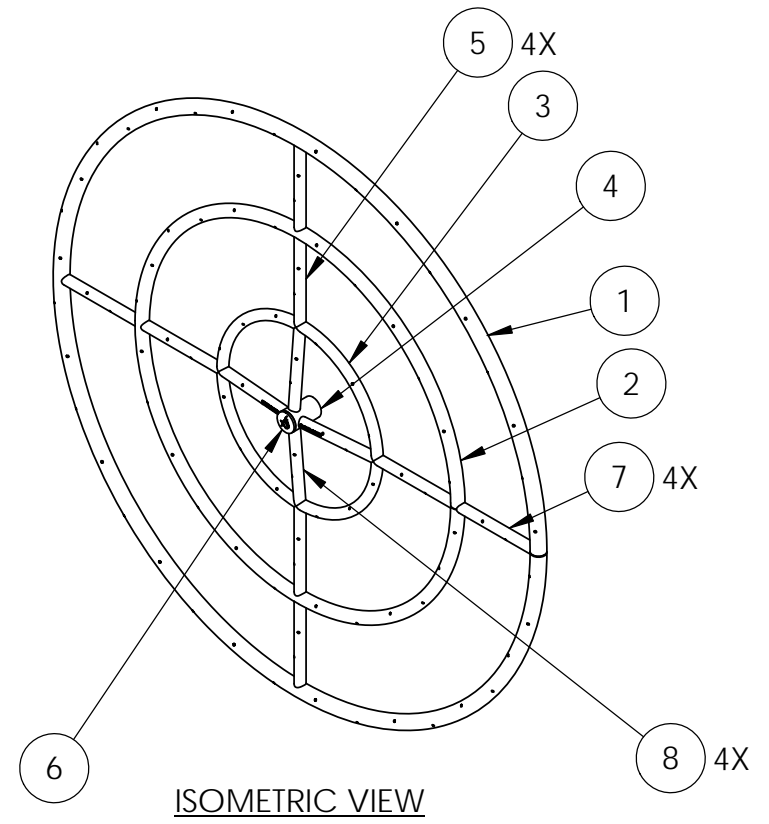

ISOMETRIC VIEW

1/8" TYP ALL SEAMS  
1/8" TYP ALL JOINTS

SECTION A-A

NOTES:

- ALL DIMENSIONS ARE IN INCHES UNLESS OTHERWISE SPECIFIED.
- MATERIAL: 304SS
- UNIT WEIGHT: \_\_\_\_\_ LBS
- FOR OUTDOOR USE ONLY

ITEM NO.	QTY.	DESCRIPTION	LENGTH
8	4	AI RND TUBE 0.625 OD x 0.058 Wall	5.17
7	4	AI RND TUBE 0.625 OD x 0.058 Wall	5.42
6	1	END CAP, 1/8" THK	
5	4	AI RND TUBE 0.625 OD x 0.058 Wall	5.73
4	1	AI RND TUBE 1.25 OD x 0.125 Wall	1.88
3	1	AI RND TUBE 0.625 OD x 0.058 Wall	35.74
2	1	AI RND TUBE 0.75 OD x 0.058 Wall	73
1	1	AI RND TUBE 0.875 OD x 0.058 Wall	110.29

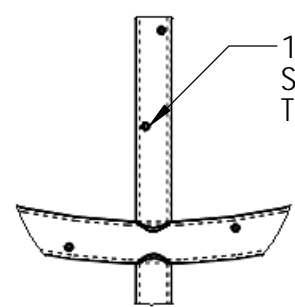

DETAIL E SCALE 2 : 7

1/8" DRILLED HOLES, EQ. SPACED STAGGERED AS SHOWN (30° / -30°) TOTAL NUMBER HOLES: 96

PROPRIETARY AND CONFIDENTIAL  
THE INFORMATION CONTAINED IN THIS DRAWING IS THE SOLE PROPERTY OF STARFIRE DIRECT. ANY REPRODUCTION IN PART OR AS A WHOLE WITHOUT THE WRITTEN PERMISSION OF STARFIRE DIRECT IS PROHIBITED.

UNLESS OTHERWISE SPECIFIED:		NAME	DATE	TITLE:
DIMENSIONS ARE IN INCHES		DRAWN		ROUND BURNER Ø 36" OD
TOLERANCES:		CHECKED		
FRACTIONAL ± 1/8"		ENG APPR.		
ANGULAR: MACH ± BEND ±		MFG APPR.		
TWO PLACE DECIMAL ±		Q.A.		SIZE
THREE PLACE DECIMAL ±		MATERIAL		DWG. NO.
INTERPRET GEOMETRIC TOLERANCING PER:		304 SS		REV
MATERIAL		FINISH		B
NEXT ASSY	USED ON	STARFIRE DESIGNS		SD-FR-36
APPLICATION		DO NOT SCALE DRAWING		SCALE: 1:7
				WEIGHT:
				SHEET 1 OF 1

SCALE: 1:7 WEIGHT: SHEET 1 OF 1