

Fire Pit H Burner Instruction Manual

This manual applies to the following product models

SD-FPH-18, SD-FPH-24, SD-FPH-30,
SD-FPH-36, SD-FPH-42

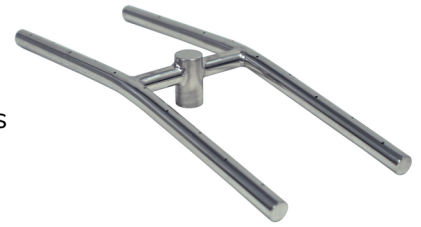

Attention: Please carefully read these instructions prior to installing your Fire Ring. Failure to adhere to these instructions may result in a possible fire hazard, explosion, property damage, serious injury, or loss of life. Do not discard this instruction manual, it must remain with the appliance.

What to do if you smell gas:

- * Do not attempt to ignite your appliance
- * Do not touch any electrical switch
- * Contact your gas supplier immediately from an off-site location
- * Contact your local fire department

Attention: This Fire Burner is for OUTDOOR USE

For use with Natural Gas or Propane Gas only. Propane installations require additional fittings and parts. See "Propane Gas Installation on page 3 of this manual for details.

Installer: Leave this manual with the appliance.

Consumer: Do not discard this manual. Save for future reference.

Attention: Installation and service must be performed by a qualified gas installer, service agency, or gas supplier. Your installer must follow these instructions carefully. Starfire Designs®, Starfire Direct, Inc. and their affiliates are not responsible for the actions of the installer.

The installation of this burner must conform to all local codes. In the absence of local codes, the National Fuel Gas Code ANSI Z223.1 or CAC/CGA-8149.1, National Gas Installation Code or CAN/CGA-B149.2, Propane Installation Code must be adhered to.

We recommend our products be installed and serviced by a member of the National Fireplace Institute who is certified as a Gas Specialist. For More information, go to www.NFICertified.org



WARNING: DO NOT TOUCH! HOT! BURN RISK! FIRE HAZARD! SEVERE BURNS OR CLOTHING IGNITION MAY RESULT IN THE IMPROPER USE OR INSTALLATION OF THIS APPLIANCE!

KEEP CHILDREN AWAY. SUPERVISE CHILDREN AT ALL TIMES WHEN IN THE AREA OF THIS APPLIANCE. INFORM ADULTS AND CHILDREN OF THE RISKS AND DANGERS OF HIGH TEMPERATURES. FLAMMABLE MATERIAL SUCH AS, BUT NOT LIMITED TO, CLOTHING SHOULD NOT BE HUNG OR STORED IN, ON, AROUND, OR ANYWHERE NEAR THE APPLIANCE.

WARNING:

- Do not store flammable liquids or vapors anywhere near this appliance.
- Solid-fuels shall not be burned in a fire pit where this decorative appliance is installed.
- Do not use this appliance if it or any part of it has been submerged beneath water.
- Never leave this appliance unattended while in use.
- Supervise children at all times.
- Flammable materials must not be placed on or near the fire.
- A qualified technician should inspect this appliance annually.
- Inspect all gas or propane supply lines prior to each use of your fire pit.
- If your fire ring is connected to a LP gas cylinder, the LP gas cylinder must be shut off after every use.

Fire Burner Specifications

SKU	Description	BTU Rating	Gas Inlet Size
SD-FPH-18	18" Stainless Steel Center Hub Fire Pit H Burner	Up to 75,000 BTU	1/2" Female NPT
SD-FPH-24	24" Stainless Steel Center Hub Fire Pit H Burner	Up to 100,000 BTU	1/2" Female NPT
SD-FPH-30	30" Stainless Steel Center Hub Fire Pit H Burner	Up to 125,000 BTU	1/2" Female NPT
SD-FPH-36	36" Stainless Steel Center Hub Fire Pit H Burner	Up to 150,000 BTU	1/2" Female NPT
SD-FPH-42	42" Stainless Steel Center Hub Fire Pit H Burner	Up to 175,000 BTU	1/2" Female NPT

Gas Supply Requirements

This Fire Ring is designed for use with Natural Gas and Propane Gas only. When installed for use with propane, additional parts and fittings are required. See Propane Gas Installation on page 3 for details.

All gas line connections must be installed by a qualified gas plumber and in accordance with all local building codes. If local codes are not available, please follow ANSI Z223.1

The Maximum BTU output of your fire feature is ultimately determined by your gas supply line and regulator. The size and length of the gas supply pipe as well as the pressure supplied by the regulator will determine the overall BTUs your fire ring will produce. Consult a qualified gas plumber to verify that your gas supply line is adequate for the size of the fire ring you choose to install.

Clearances To Combustibles

Maintain a minimum horizontal clearance of 36" to combustible materials and a minimum vertical clearance of 96" (see Img. 2-1)

Fire rings with a rating of 200,000 BTUs or higher and fire rings connected to a gas source with the rating 200,000 BTUs or higher must not be installed under any sort of overhang or cover.

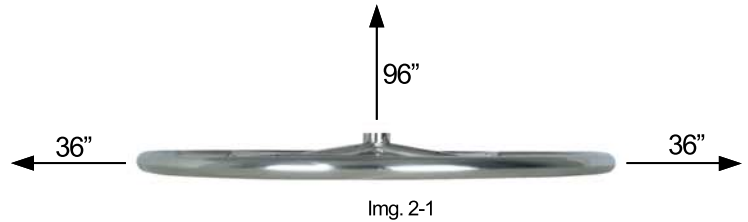

Fire Ring Installation

IMPORTANT: For all Natural Gas and Propane Gas installations, use gas appropriate pipe tape or pipe joint compound on all NPT fittings. Do NOT use pipe tape or pipe joint compound on FLR or compression fittings. If using this fire pit ring with an electronic ignition flame control system, please follow the installation instructions included with the electronic ignition flame control system. Vents (11) are recommended for all fire pit installations and are required when using Propane Gas or if you are installing an Electronic Ignition Flame Control System.

Natural Gas Installation - Match Lit (Img. 2-2):

- Run a Natural Gas Supply Line (1) to the location of the Fire Pit Enclosure (2). Your Fire Pit Enclosure must be constructed of non-combustible materials (brick, stone, metal, concrete, etc.).
- Install the Form Fitting Fire Pit Ledge (3) around the inside perimeter of your Fire Pit Enclosure. The ledge should be between 2.5" and 4" down from the very top cap of your fire pit.
- Thread the Fire Ring (4) to the top of the Burner Pan (5).
- Thread a 90° Elbow Fitting (6) to the bottom of the Burner Pan.
- Connect one end of a Whistle-Free Flex Connector (7) to the 90° Elbow Fitting, then connect the other end to your Key Valve (8).
- The Key Valve must be installed no more than 3 feet away from your Fire Ring, ideally in the wall of your Fire Pit Enclosure.
- Your Key Valve may then be connected to the Natural Gas Supply Line using another Whistle-Free Flex Connector (9) or hard gas pipe.
- Rest the Burner Pan on the Form Fitting Fire Pit Ledge with the Fire Ring facing up.
- Cover your Fire Ring with your choice of Starfire Glass® brand fire glass, lava rock, or other approved fire pit media.

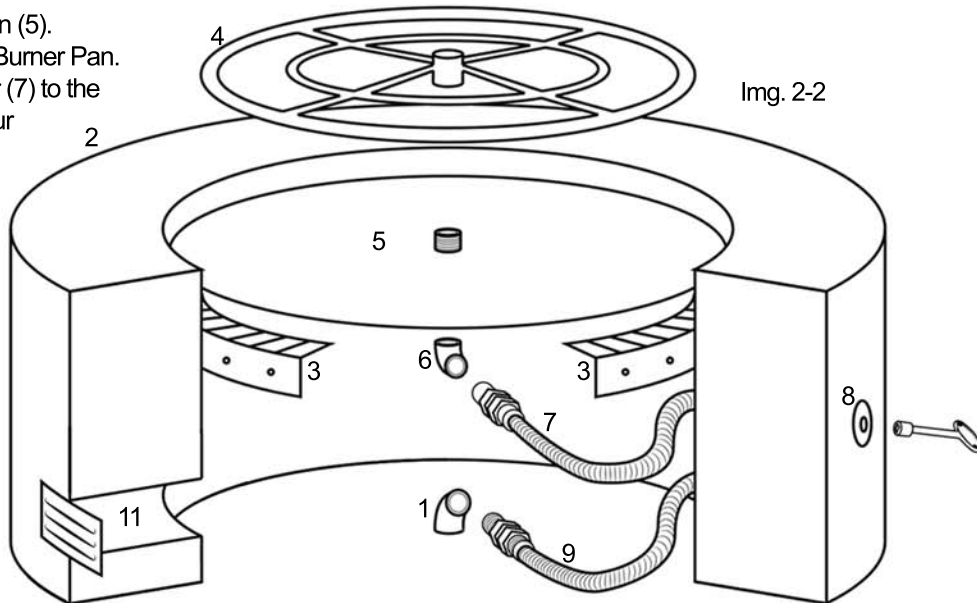

Don't Forget the Fire Glass!

Our Fire Rings are specifically designed for use with Starfire Glass® brand fire glass.

Scan the code or go to www.StarfireDirect.com/StarfireGlass.



How Much Fire Glass Do You Need?

To determine the amount of glass needed for your particular fire pit, use our handy online Fire Glass Calculator.

Scan the code or Go to www.StarfireDirect.com/Fireglass-Calculator.



Fire Ring Installation (Continued)

Propane Gas Installation - Match Lit (Img. 3-1):

Propane gas is much different than Natural Gas and requires a Propane Air Mixer Orifice for proper combustion. Propane is heavier than air and it is possible that un-combusted Propane may sink to the bottom of your fire pit enclosure. For this reason, you must ensure that your fire pit enclosure has plenty of air ventilation (11). Your propane fire pit will require a minimum of two 18 square inch vents which should be located toward the very bottom of your fire pit. These vents prevent un-combusted propane from storing up in your fire pit enclosure and they provide a steady flow of oxygen to the Propane Air Mixer Orifice. If using Fire Glass, make sure the Fire Ring is not buried in more than 1" of Fire Glass.

- Run your Propane Gas Supply Line (1) to the location of the Fire Pit Enclosure (2). Your Fire Pit Enclosure must be constructed of non-combustible materials (brick, stone, metal, concrete, etc...)
- Install the Form Fitting Fire Pit Ledge (3) around the inside perimeter of your Fire Pit Enclosure. The ledge should be between 2.5" and 4" down from the very top cap of your Fire Pit Enclosure.
- Thread the Fire Ring (4) to the top of the Burner Pan (5).
- Thread a 90° Elbow Fitting (6) to the bottom of your Burner Pan.
- Thread a Propane Air Mixer (7) into the 90° Elbow Fitting. Make sure the arrow on the Propane Air-Mixer is pointing in the direction of the flow of gas.
- Connect one end of a Whistle-Free Flex Connector (8) to the Propane Air Mixer, then connect the other end to your Key Valve (9).
- The Key Valve must be installed no more than 3 feet away from your burner, ideally being installed in the wall of your Fire Pit Enclosure.
- Your Key Valve may then be connected to the Propane Gas Supply Line using another Whistle-Free Flex Connector (10) or hard gas pipe.
- Rest the Burner Pan on the Form Fitting Fire Pit Ledge with the Fire Ring facing up.
- Test your Fire Ring (See fire ring ignition instructions).
- Cover your Fire Ring with your choice of Starfire Glass® brand fire glass, lava rock, or another approved fire pit media.

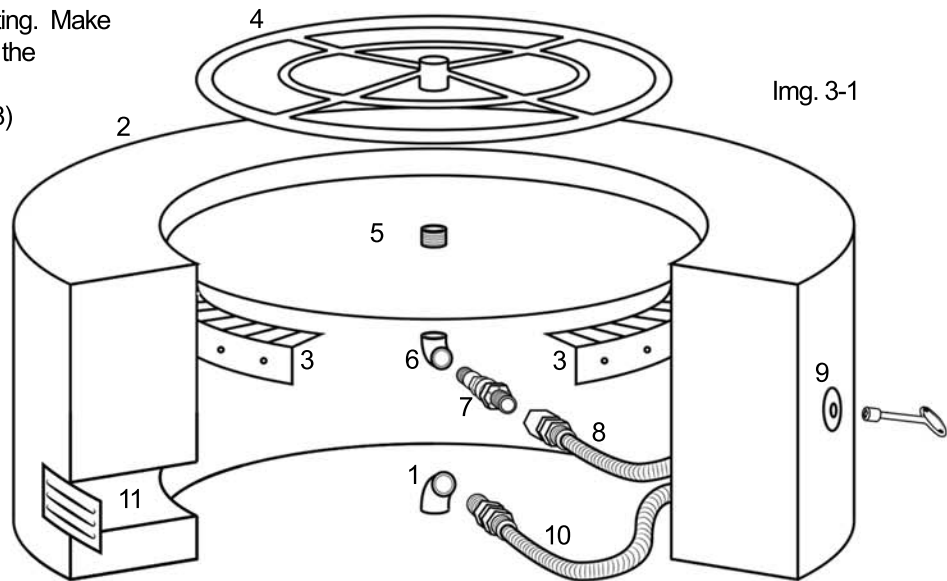

 **Video Tutorials Available***

 Scan this code to view our installation video or go to www.StarfireDirect.com/Video-Gallery

*Videos are for reference only and do not supersede these written instructions.

All the additional fittings and parts needed to install your Fire Ring can be purchased online at www.StarfireDirect.com.

Scan this code to get started:



Operation

Be sure your fire pit is free from flammable liquids or combustible materials. If you smell gas do not attempt to ignite your fire pit.

How to Ignite your Fire Ring Manually:

1. Use a long-necked butane lighter and hold the flame over the burner.
2. Slowly turn the Key Valve to the ON position. Your burner should light.
3. If the burner does not light, immediately turn the valve to the OFF position.
4. Wait 5 minutes to clear out any gas and repeat the above steps.
5. If your burner fails to light for a third time, turn the gas valve off and contact your dealer or a local gas technician.
6. To turn your fire off, turn the valve to the OFF position. Be sure the valve is fully off to avoid any gas leakage.

If your burner is installed with an electronic ignition system or other type of flame control system, follow the lighting instructions that came with the flame control system carefully.

Maintenance

Inspection and maintenance to this appliance and the enclosure it is installed in should be done by a qualified service technician on an annual basis. Ensure that the burner and air vents are kept clean. Keep your fire pit free of debris. Make sure the burner ports on your Fire Ring are free of blockage. Insects are attracted to the smell of gas and may cause blockage. Check the burner ports and clear any debris if present. If a flame control system has been installed, refer to the cleaning and maintenance instructions that came with your flame control system. Do not use appliance in high wind environments. Before using this appliance, inspect the unit to ensure no combustible debris or material is on or near the fire ring.

Troubleshooting

Symptom	Cause	Solution
1. Heavy sooting	A. No Air Mixer installed on propane set up	A. Install a Propane Air Mixer
	B. Air Mixer is installed but there is not enough ventilation in the fire pit base	B. Make sure you have a minimum of two 18 square inch vents installed in the base of your fire pit enclosure.
2. Low flame	A. Insufficient gas supply	A. Ensure that your plumbing is providing the appropriate amount of gas for the size Fire Ring installed. Other gas appliances may be competing with your fireplace. Shut off other gas appliances. Consult a qualified gas technician or installer.
	B. Blockage or kink in gas connections	B. Clean blockage. Unkink lines and connectors. Line may need to be replaced.
	C. Valve not completely open	C. Open valve completely
3. Uneven flame	A. Blocked burner ports	A. Clear blocked burner ports
	B. Not enough gas pressure	B. Consult gas installer or plumber
	C. Fire Glass may be packed down too much	C. Loosen media around burner with a hard stick or pipe. Do not use bare hands.
	D. Valve not completely open	D. Open valve completely
4. Flame spreads too much or flares up	A. Too much media on top of Fire Ring	A. Remove some of the Fire Glass or Fire Pit Media from on top of your Fire Ring. Propane installations should have no more than 1" of Fire Glass covering the top of the Fire Ring.

Warranty Information

Limited Warranty:

Starfire Designs® warrants this Fire Ring against defects in materials and workmanship for a period of 10 years from the date of purchase. This warranty is for the benefit of the original purchaser. Starfire Designs® agrees to repair or provide a replacement for the defective product, but will not remove the defective product or reinstall the replacement product. Starfire Designs® must be contacted within 15 days of discovering the defect. Do not return your defective product without written authorization from Starfire Designs®. Defective product returned without proof of purchase date will not be covered under warranty and will be serviced or replaced at an additional expense to the original purchaser. This warranty does not cover damage caused by freight or parcel carriers, such as but not limited to, UPS, FED-EX, USPS, DHL. If your product is damaged in transit, please file a claim with the carrier immediately.

After receiving authorization from Starfire Designs®, please return defective product to:

Starfire Direct, Inc.
42168 Remington Ave.
Temecula, CA 92590

Please Note: Address subject to change. Shipping charges are the responsibility of the buyer.

Exclusions:

Starfire Designs® will not warrant any product found to be misused, abused, or installed contrary to the instructions provided in the owner's manual. Starfire Designs® is not liable for the loss, theft, damage, neglect, or misuse of this product. This warranty does not cover any Starfire Designs® product that has been modified, altered, or repaired by someone other than the Starfire Designs® factory or any person/entity that has been expressly approved by Starfire Designs®. Starfire Designs® is not liable for product color changes. Starfire Designs® will not warranty parts or fittings from third party manufacturers that are used to install our products. Starfire Designs® and Starfire Direct, Inc. are not liable for any and all claims by the purchaser of our products as a result of damage or personal injury resulting from the sale, assembly, installation, operation, shipment, storage, or manufacture of this product.