

ISOMETRIC VIEW

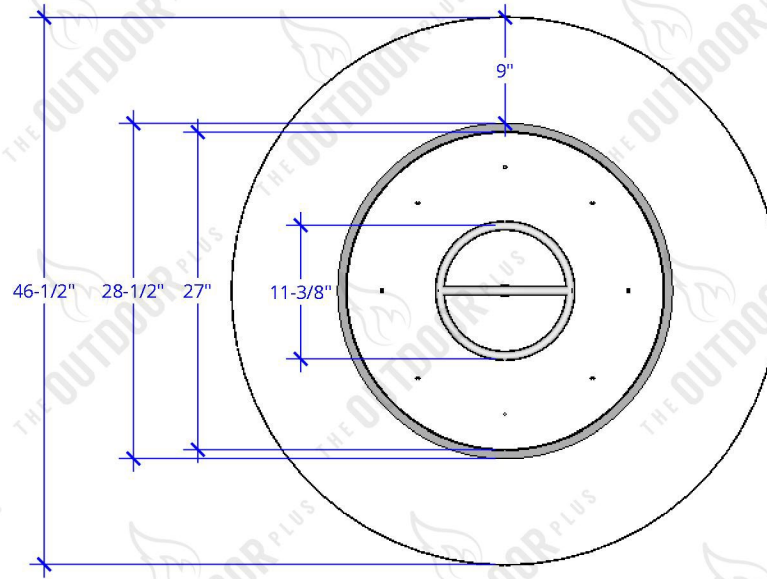

TOP VIEW



FRONT VIEW

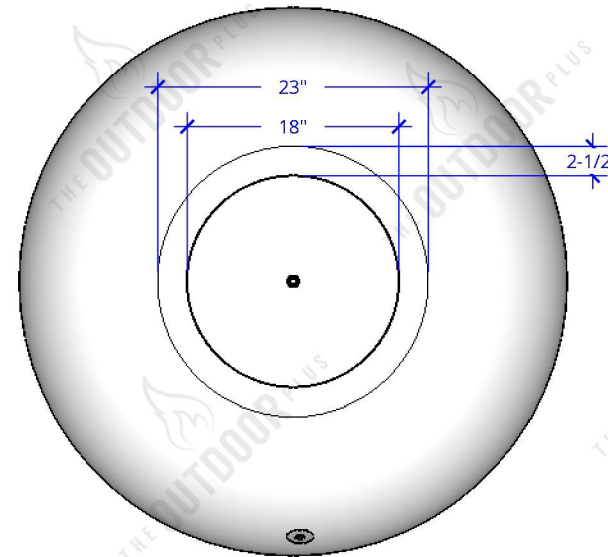

RIGHT VIEW

48in Sedona Wide Ledge Fire Pit - Match Lit	
SKU	OPT-SEDWL48
Material	GFRC Concrete
Finish	18 Color Options
Gas Type	NG or LP
Weight	Approx. 350 LBS.
BTUs	Approx. 65,000
Sugg. Fire Glass	Approx. 75 LBS.